

Chapter 5 Water Infrastructure

Chapter 5	Water Infrastructure	5-4
5.1	Key Terms	5-4
5.1.1	Abbreviations	5-4
5.1.2	Definitions	5-6
5.2	General Information	5-7
5.2.1	Policy	5-7
5.2.2	System Maps	5-8
5.2.3	Water System	5-8
5.2.4	DSG Design Resources	5-11
5.3	General Requirements	5-12
5.3.1	Industry Standards	5-12
5.3.2	Regulations	5-16
5.4	Basis of Design	5-17
5.4.1	Basis of Design Report	5-17
5.4.2	Basis of Design Plan Sheet	5-18
5.5	Design Process	5-19
5.6	Distribution and Feeder Main Design	5-20
5.6.1	Modeling and Main Sizing	5-20
5.6.2	Location	5-20
5.6.3	Materials	5-24
5.6.4	Chambers (Vaults)	5-38
5.6.5	Appurtenances	5-43
5.6.6	Rehabilitation of Existing Mains	5-73
5.6.7	SCADA	5-73
5.6.8	Corrosion Control	5-74
5.7	Water Service Connections	5-77
5.8	Transmission Main Design	5-77
5.8.1	Modeling and Main Sizing	5-77
5.8.2	Location	5-78
5.8.3	Transmission Mains	5-78
5.8.4	Interconnection of Parallel Mains	5-83
5.8.5	Rehabilitation of Existing Mains	5-84
5.8.6	Emergency Pump Connections	5-84

5.8.7	SCADA	5-84
5.8.8	Corrosion Control	5-84
5.9	Water Storage Tanks, Standpipes and Reservoir Design	5-85
5.9.1	Planning	5-85
5.9.2	Water Storage Facility Structures	5-89
5.9.3	Hydraulic Mixing for Water Age and Water Quality Control.....	5-92
5.9.4	Water Level and Flow Measurement.....	5-94
5.9.5	Mechanical Appurtenances and Equipment.....	5-94
5.9.6	Multi-Use Facilities	5-97
5.9.7	Landscaping and Weed/Pest Control	5-97
5.9.8	Access and Security	5-97
5.9.9	Water Quality Monitoring/Sampling	5-99
5.9.10	Disinfection and Dechlorination	5-100
5.9.11	Removal from Service.....	5-101
5.9.12	Standby Power	5-103
5.10	Seismic Design.....	5-103
5.10.1	Terms	5-103
5.10.2	Seismic Design Standards for New Water Mains.....	5-105
5.10.3	Repairs in Alignments That Require Earthquake-Resisting Pipe	5-108
5.10.4	Seismic Design of Buildings, Tanks/Reservoirs. Other SPU Water System Structures and Nonstructural Elements.....	5-109
5.10.5	Commentary	5-110
5.10.6	References	5-114
5.11	Construction.....	5-114
5.11.1	Requirements for Protecting Water Mains and Appurtenances	5-114
5.11.2	Removal and Abandonment of Existing Water Mains and Appurtenances.....	5-117
5.11.3	Construction, Startup and Acceptance Procedures	5-118
5.11.4	Temporary Thrust Restraint.....	5-121
5.11.5	Customer Impacts and Service Disruptions.....	5-121
5.11.6	Emergency Pump Connections.....	5-122
5.12	Operations and Maintenance	5-122
5.12.1	Water Easements.....	5-122
5.13	Resources	5-124

Appendices

Appendix 5A: Settlement Monitoring Requirements for Cast Iron Water Mains

Appendix 5B: Settlement Monitoring Requirements for Ductile Iron Water Mains

Appendix 5C: Inspection Guidelines for Water Storage Facilities

Appendix 5D: 1927 Cast Iron Pipe Handbook

Appendix 5E: Washington State Department of Health 2019 Water System Design Manual
 Appendix 5F: Joint Property Use Memorandum of Agreement between Seattle Parks and Recreation and SPU

List of Figures

Removed for Security

Figure 5-2 Typical Layout of SPU Water System Infrastructure5-10
 Figure 5-3 Basis of Design Plan Sheet Data for Water Infrastructure (Example).....5-19
 Figure 5-4 Controlled Density Fill.....5-27
 Figure 5-5 Typical Layout of a 16-inch or Larger Line Valve in Driving Surface5-40
 Figure 5-6 Pressure Zone Boundary District Valve Co-Located with a Standard Plan Type 311 Fire Hydrant5-46
 Figure 5-7 Pressure Zone Boundary Check Valve Co-Located with Fire Hydrant.....5-56
 Figure 5-8 Example of Valves on All Mains at Grid Junctions5-62
 Figure 5-9 Example of Intermediate Valves at Cross Streets.....5-63
 Figure 5-10 Example of Intermediate Valves in SFR Zones5-63
 Figure 5-11 Example of Intermediate Valve Spacing – Partial SFR Zoning.....5-64
 Figure 5-12 Example of 1/4 Mile Valve Spacing for Large Diameter Mains5-64
 Figure 5-13 Example of 1/4 Mile Valve Spacing Not Appropriate with Grid-Integrated Feeder5-65
 Figure 5-14 Example of Line Valves Added to Feeder Main.....5-65
 Figure 5-15 Main Separation between Feeder and Grid.....5-66
 Figure 5-16 Example of Improved Reliability from Adding Connections.....5-66
 Figure 5-17 Local Mains and Water Service Headers to Mitigate Feeder Main Shutdown Impacts5-67
 Figure 5-18 Default Positioning of Grid Junction Line Valves for All-New Construction5-68
 Figure 5-19 Existing Grid Junction Modification when Connecting New Looped Grid Main.....5-68
 Figure 5-20 Reconstruction Grid Junction with Ductile Iron5-69
 Figure 5-21 Line Valve Positioning to Create Multiple Independent Feeds.....5-70
 Figure 5-22 Seal Welds.....5-91

List of Tables

Table 5-1 Key Components in SPU Water System Infrastructure.....5-9
 Table 5-2 AWWA Standards and Specifications for SPU Water Facilities.....5-12
 Table 5-3 AWWA Design Manuals for Water Supply Practice.....5-14
 Table 5-4 Design Criteria List for a Typical Water Distribution Main Design (Example).....5-17
 Table 5-5 Clearances to Water Mains5-22
 Table 5-6 Required Gas Main Clearances5-23
 Table 5-7 Standard Materials for SPU Distribution and Feeder Mains5-25
 Table 5-8 Valve Uses within SPU Water System5-60
 Table 5-9 Steel Pipe Coating Types for SPU Water System5-75
 Table 5-10 Ductile Iron Pipe Coating Types for SPU Water System5-76
 Table 5-11 Sample Requirements for Routine Operation of Water Storage Facilities.....5-87
 Table 5-12 Water Main Criticality Terms5-103
 Table 5-13 Earthquake Hazard Exposure Terms5-104
 Table 5-14 Minimum Water Main Design & Construction Analysis & Performance Requirements5-105
 Table 5-15 Common Construction Conditions and Protection Measures for Water Mains.....5-115
 Table 5-16 Hazardous Materials associated with SPU Water System.....5-118
 Table 5-17 SPU Minimum Water Easements5-123

Chapter 5 WATER INFRASTRUCTURE

This chapter of the Design Standards and Guidelines (DSG) presents standards and guidance for Seattle Public Utilities' (SPU's) water infrastructure. This includes transmission and distribution pipelines, storage tanks, standpipes, and reservoirs. DSG standards are shown as underlined text. The primary audience for this chapter is SPU engineering staff.

The information in this chapter should be used in conjunction with other DSG standards. For water service connections, see [DSG Chapter 17, Water Service Connections](#). For corrosion control issues, see [DSG Chapter 6, Cathodic Protection](#).

***Note:** This DSG does not replace the experienced engineering judgment of a registered professional engineer. All design for upgrades, repairs, and new infrastructure should be prepared under the supervision of an experienced licensed engineer.*

5.1 KEY TERMS

Abbreviations and definitions given here follow either common American usage or regulatory guidance. For standard City of Seattle (City) abbreviations for construction drawings, see [City Standard Specifications section 1-01.2 and City Standard Plans 002a through 002f](#).

5.1.1 Abbreviations

Abbreviation	Term
AC	asbestos concrete
AASHTO	American Association of State Highway and Transportation Officials
AREMA	American Railway Engineering and Maintenance-of-Way Association
ARV	air release valve
ASCE	American Society of Civil Engineers
AVV	air and vacuum valve
ASTM	Formerly American Society for Testing Materials; now known as ASTM International
AWS	American Welding Society
AWWA	American Water Works Association
BFV	butterfly valve
BNSF	Burlington Northern Santa Fe
CAV	combination air valve (includes both air release and air vacuum functions)
CDF	controlled density fill

Abbreviation	Term
CI	cast iron
CIP	Capital Improvement Program
CiPP	cured in place pipe
CSO	combined sewer overflow
DDGV	double-disc gate valve (AWWA C500)
DI	ductile iron
DIPRA	Ductile-Iron Pipe Research Association
DOH	Washington State Department of Health
DV	district valve
ECA	environmentally critical area
ERDIP	earthquake-resistant ductile iron pipe
fps	feet per second
ft	foot or feet
gpm	gallons per minute
GV	gate valve
HDD	horizontal directional drilling
HDPE	high-density polyethylene
HGL	hydraulic grade line
HP BFV	high-pressure butterfly valve
HPA	Hydraulic Project Approval
HPC	heterotrophic plate count
IBC	International Building Code
ID	inside diameter
LOB	line of business
mgd	million gallons per day
MJ	mechanical joint
NACE	National Association of Corrosion Engineers
NPDES	National Pollutant Discharge Elimination System
NSF	National Sanitation Foundation
O&M	operations and maintenance
OD	outside diameter
OSHA	Occupational Safety and Health Administration
PR valve	pressure regulating valve, regulating valve, PRg, or pressure regulator (all used synonymously)

Chapter 5 Water Infrastructure

Abbreviation	Term
PRV	pressure relief valve
psi	pounds per square inch
psig	pounds per square inch gauge
QA/QC	quality assurance/quality control
RE	resident engineer
RJ	restrained joint
RMJ	restrained mechanical joint, typically a WRG used on MJ
ROV	remotely operated vehicle
ROW	right-of-way
RWGV	resilient wedge gate valve (AWWA C509)
SCADA	Supervisory Control and Data Acquisition
SCL	Seattle City Light
SDCI	Seattle Department of Construction and Inspections
SDOT	Seattle Department of Transportation
SDWA	Safe Drinking Water Act
SMT	Seattle Municipal Tower
SPU	Seattle Public Utilities
TC	total coliform
VV	vacuum valve
WAC	Washington Administrative Code
WISHA	Washington Industrial Safety and Health Administration
WPPM	Water Planning & Program Management
WRG	wedge restraining gland
WSDOT	Washington State Department of Transportation

5.1.2 Definitions

Term	Definition
anode	Location where metal is corroded.
cathodic protection	A means of providing a sacrificial material (usually a metal) to become the point where corrosion occurs. Cathodic protection is a technique used to provide corrosion control to buried or submerged metallic materials. Cathodic protection shifts the electrical potential off anodic sites in a pipeline or other structure. See also anode.
Capital Improvement Program (CIP)	Administered by SPU through its Capital Planning Committee (CPC) to plan, budget, schedule, and implement capital improvement projects, including flooding and conveyance improvements, protection and enhancement of water quality and habitat, protection of infrastructure, and drainage improvements within projects of other City agencies.

Term	Definition
Customer Service	The section within SPU through which customers purchase all new water services and receive notification of planned outages.
engineering	Generic term for SPU staff responsible for plan review and utility system design for CIP projects.
guidelines	Advice for preparing an engineering design. Design guidelines document suggested minimum requirements and analysis of design elements to produce a coordinated set of design drawings, specifications, or lifecycle cost estimates. Guidelines answer what, why, when, and how to apply design standards and the level of quality assurance (QA) required.
O&M	Generic term for SPU staff responsible for operations and maintenance and their related activities.
resistivity	The resistance of an environment (either water or soil) to the flow of electrical current.
standards	Drawings, technical or material specifications, and minimum requirements needed to design a particular improvement. A design standard is adopted by the department and generally meets the functional and operational requirements at the lowest lifecycle cost. It serves as a reference for evaluating proposals from developers and contractors. For a standard, the word “must” refer to a mandatory requirement. The word “should” is used to denote a flexible requirement that is mandatory only under certain conditions.
Water Quality	A section within SPU that takes water samples and performs drinking water quality tests on new and existing water mains and inspects construction projects to assure pipe work is kept clean.

5.2 GENERAL INFORMATION

SPU water facilities supply water to more than 1.3 million people in the Seattle area, including wholesale customers (purveyors). The Tolt and Cedar watersheds supply most of the drinking water. The City well fields serve as a supplemental water source during droughts and emergencies. Large transmission pipelines deliver water to treatment plants, and from the plants to in-town storage facilities such as tanks and reservoirs. Smaller water pipelines distribute water from in-town storage facilities to the public. Valves control water and isolate sections in the distribution mains, which are monitored by Supervisory Control and Data Acquisition (SCADA). Water services and fire hydrants are connected to distribution mains. Purveyors are connected to transmission mains.

In the SPU system, most water flows via gravity from the watersheds to storage facilities in the City. Storage facilities are set at high elevations to supply water via gravity to customers. Where necessary, pumps are used to lift water to higher elevation storage facilities or to increase water pressure. The system is managed by SPU Operations and monitored through SCADA.

5.2.1 Policy

The guiding policy document for water infrastructure is the [SPU 2019 Water System Plan](#). See Chapter 4 of the plan for SPU policy on water transmission. See Chapter 5 of the plan for SPU policy on water distribution.

5.2.2 System Maps

SPU's water maps are available at the following locations:

- [Basemaps](#) in Seattle Engineering Records Vault

Removed for Security



5.2.3 Water System

The SPU water system is comprised of raw water watershed reservoirs, transmission pipelines, treatment plants, pump stations, treated water storage facilities and distribution pipelines in pressure zones. 

Removed for Security



The SPU water distribution system contains more than 1,690 miles of water mains. These mains vary in diameter from 4 inches to greater than 30 inches. Most SPU water mains are unlined or mortar-lined cast iron, ductile iron, or steel pipe.

The City's water distribution system also includes 19 pump stations and more than 180,000 water service lines and meters serving residential and non-residential properties. Generally, both transmission and distribution mains passing under railroads or similar facilities are encased. Most pipelines do not have corrosion protection. See [DSG Chapter 6, Cathodic Protection](#).

See also: [DSG Chapter 11, Pump Stations](#) and [DSG Chapter 17, Water Service Connections](#).

For more information on the history and condition of the water distribution system, see the [2019 Water System Plan](#).

5.2.3.1 Infrastructure Elements

Table 5-1 shows key components in SPU water system infrastructure.

Table 5-1
Key Components in SPU Water System Infrastructure

Infrastructure	Description
Water Main	
transmission main	Large diameter (generally >3 ft) pipeline that transfers water from source to feeder mains or storage tanks. There are no service connections on transmission lines, except for purveyors.
feeder main	Smaller diameter pipelines (generally <3 ft) are the backbone of SPU distribution mains. New taps are not permitted on feeder mains except for feeder-distributor mains meeting current design standards for distribution mains.
distribution main	Small to mid-sized pipeline (<2 ft) used to distribute water from a feeder main to a local service area. Distribution mains have service connections to adjacent properties.
Storage Facility	
standpipe	An above-ground vertically oriented pipe or water containment structure with a height that is generally greater than the diameter. Used where additional height is needed for water storage, to provide additional pressure without constant pumping and in some cases to provide air venting on large transmission pipelines whose hydraulic grade line (HGL) that operates very near atmospheric pressure.
reservoir	Structure that is at or below ground level with a diameter or footprint that is typically greater than the height. Reservoirs are usually large in size and storage capacity.
elevated tank	Elevated tanks have a supporting structure that elevates the lower operating elevation of water in the tank to a level above ground elevation.

Figure 5-2 shows the typical layout of SPU water system infrastructure.

Figure 5-2
Typical Layout of SPU Water System Infrastructure

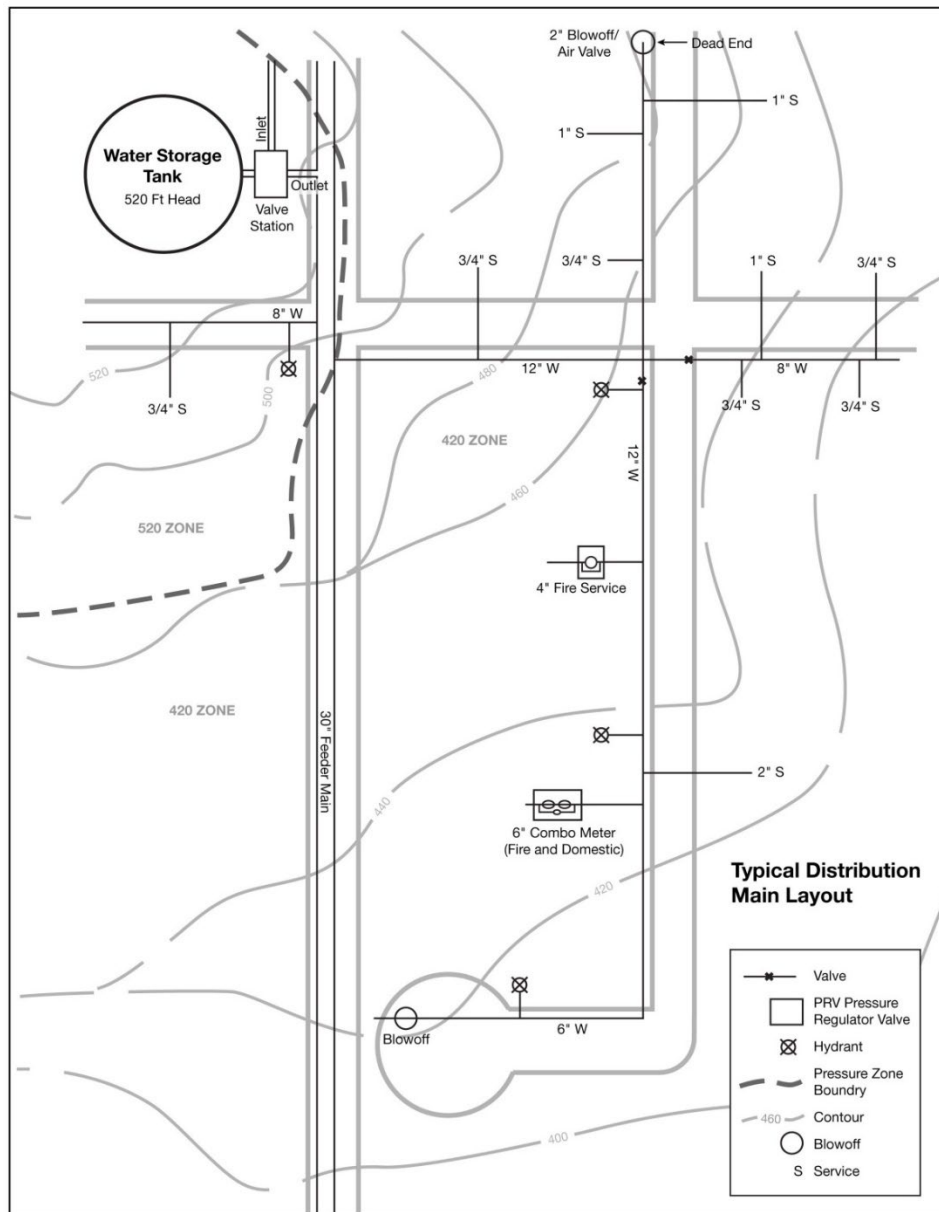

5.2.3.2 Pressure Zones

The SPU water distribution system is divided into approximately 45 pressure zones that operate within a pressure range of about 30 to 130 pounds per square inch (psi). Individual zones are separated by closed line valves, called district valves (DVs), pressure regulators, and control valves. Pressure zone boundaries are shown in the 400-foot (ft) map books and in GIS. SPU Water Planning & Program Management (WPPM) specifies the pressure zone to which new water mains and service connections will be added. See DSG section 5.6.1.2.

5.2.3.3 Transmission System

The SPU regional and subregional water transmission system includes 189 miles of 16- to 96-inch steel, ductile iron, or concrete pipeline. These are a few of the largest transmission pipelines:

- Lake Youngs Supply Lines 4 and 5
- Cedar River Pipelines 1 through 4
- Tolt Pipelines 1 and 2
- Eastside Supply Line
- Mercer Island Pipeline
- West Seattle Pipeline

The major supply transmission pipelines from the Cedar and Tolt sources deliver water to wholesale customer master meters and intertie locations, such as the City of Tukwila.

Transmission pipelines deliver water to various tanks, standpipes, and reservoirs throughout the system and on occasion directly to the distribution system. Fourteen reservoirs and 12 tanks comprise the in-town storage facilities. Water from the in-town facilities is distributed to customers via the distribution system.

The City's water transmission system also includes 11 pump stations.

5.2.3.4 Distribution and Feeder System

Distribution mains are smaller diameter (< 3 ft) pipes that carry water from a source (reservoir or tank) to a local service area (neighborhood or city block). Feeder mains are similar to transmission mains except that distribution and service connections are allowed.

5.2.4 DSG Design Resources

DSG design resources include technical or material specifications developed specifically for and found only in the DSG. They include drawings, standard specifications, and other technical guidelines not available from other sources:

- **Settlement monitoring requirements.** Settlement monitoring requirements for water mains are in Appendices 5A and 5B:
 - Settlement Monitoring Requirements for Cast Iron Mains ([Appendix 5A](#))
 - Settlement Monitoring Requirements for Ductile Iron Mains ([Appendix 5B](#))
- **Inspection Guidelines for Water Storage Facilities.** ([Appendix 5C](#))
- **1927 Cast Iron Pipe Handbook.** Historical reference for existing early cast iron water mains in the system ([Appendix 5D](#)).
- **Washington State Department of Health (DOH) 2019 Water System Design Manual, 4th Edition.** Current DOH regulations covering state-mandated water system design requirements and offering additional optional best practices topics ([Appendix 5E](#)). See also, DSG section 5.3.2.4B.

5.3 GENERAL REQUIREMENTS

The design engineer must be familiar with water industry standards and code requirements.

If industry standards and City requirements or regulations conflict, the design engineer should discuss the discrepancy with the water line-of-business (LOB) representative, the Water Quality representative, and the Operations manager as applicable. Notify the owner of this DSG chapter of the conflict and its resolution for inclusion in the next Chapter 5 update.

5.3.1 Industry Standards

Water facilities should be designed to American Water Works Association (AWWA) standards unless the design engineer can show why the AWWA standards do not meet the project requirements. **Additionally, water facilities must meet Seattle-King County and DOH standards.**

Water storage facility design standards for SPU must also meet standards set forth in the Water Research Foundation’s Maintaining Water Quality in Finished Water Reservoir.

5.3.1.1 American Water Works Association

Following AWWA standards and specifications is strongly advised where possible, except when superseded by stricter requirements set forth in this DSG, DOH regulations, and City Standard Specifications and Plans.

Table 5-2 lists relevant AWWA standards and specifications, organized by subject and intended as minimum requirements. **Removed for Security**

It is the design engineer's responsibility to use the latest version of these standards.

**Table 5-2
AWWA Standards and Specifications for SPU Water Facilities**

Designation	Title
Ductile-Iron Pipe	
C104/A21.4	Cement Mortar Lining for Ductile Iron (DI) Pipe and Fittings for Water
C105/A21.5	Polyethylene Encasement for DI Pipe Systems
C111/A21.11	Rubber-Gasket Joints for DI Pressure Pipe and Fittings
C115/A21.5	Flanged DI Pipe with Ductile Iron or Gray Iron Threaded Flanges
C116/A21.16	Protective Fusion-Bonded Epoxy Coatings Interior or Exterior Surface DI
C150/A21.50	Thickness Design of Ductile Iron Pipe
C151/A21.51	DI Pipe; Centrifugally Cast, for Water or Other Liquids
C153/A21.53	DI Pipe; Compact Fittings for Water Service
Steel Pipe	
C200	Steel Water Pipe 6” and larger
C203	Coal-Tar Protective Coatings and Linings for Steel Water Pipelines, Enamel and Tape, Hot-Applied

Designation	Title
C205	Cement-Mortar Protective Lining and Coating for Steel Water Pipe, 4" and Larger, Shop Applied
C206	Field Welding of Steel Water Pipe
C207	Steel Pipe Flanges for Waterworks Service Sizes 4"-144"
C208	Dimensions for Fabricated Steel Water Pipe Fittings
C210	Liquid-Epoxy Coating Systems for the Interior and Exterior of Steel Water Pipelines
C213	Fusion-Bonded Epoxy Coating for the Interior and Exterior of Steel Water Pipelines
C215	Extruded Polyolefin Coatings for the Exterior of Steel Water Pipelines
C216	Heat-Shrinkable Cross-Linked Polyolefin Coatings for the Exterior of Special Sections, Connections and Fittings for Steel Water Pipes
C217	Petrolatum and Petroleum Wax Tape Coatings for the Exterior of Connections and Fittings for Steel Water Pipelines
C218	Coating the Exterior of Aboveground Steel Water Pipelines and Fittings
C219	Bolted, Sleeve-Type Couplings for Plain-End Pipe
C220	Stainless-Steel Pipe, ½" and Larger
C221	Fabricated Steel Mechanical Slip-Type Expansion Joints
C222	Polyurethane Coatings for the Interior and Exterior of Steel Water Pipe and Fittings
C223	Fabricated Steel and Stainless Steel Tapping Sleeves
C224	Nylon-11 Based Polyamide Coating System for the Interior and Exterior of Steel Water Pipe and Fittings
C225	Fused Polyolefin Coating Systems for the Exterior of Steel Water Pipelines
C226	Stainless Steel Fittings for Waterworks Service, Sizes ½"-72"
Valves/ Hydrants	
C502	Dry-Barrel Fire Hydrants
C504	Rubber-Seated Butterfly Valves
C507	Ball Valves, 6"- 48"
C508	Swing-Check Valves for Waterworks Service, 2"- 24" National Pipe Size (NPS)
C509	Resilient-Seated Gate Valves for Water Supply ductile iron only
C510	Double Check Valve Backflow Prevention Assembly
C511	Reduced-Pressure Principal Backflow Prevention Assembly
C512	Air Release, Air/Vacuum, and Combination Air Valves for Waterworks Service
C513	Open-Channel, Fabricated-Metal, Slide Gates and Open-Channel, Fabricated-Metal Weir Gates
C515	Reduced-Wall, Resilient-Seated Gate Valves for Water Supply Service (Does not meet City Spec, but can be used in special cases)
C517	Resilient-Seated Cast-Iron Eccentric Plug Valves

Designation	Title
C540	Power-Actuating Devices for Valves and Slide Gates
C550	Protective Epoxy Interior Coatings for Valves and Hydrants
C560	Cast-Iron Slide Gates
C561	Fabricated Stainless Steel Slide Gates
C563	Fabricated Composite Slide Gates
Pipe Installation	
C600	Installation of Ductile-Iron Water Mains and Their Appurtenances
C602	Cement-Mortar Lining of Water Pipelines in Place—4” and Larger
C606	Grooved and Shouldered Joints
C900	PVC Water Transmission & Distribution Pipe
Disinfection	
C651	Disinfecting Water Mains
C652	Disinfection of Water-Storage Facilities
Storage	
D100	Welded Carbon Steel Tanks for Water Storage
D102	Coating Steel Water-Storage Tanks
D103	Factory-Coated Bolted Steel Tanks for Water Storage
D104	Automatically Controlled, Impressed-Current Cathodic Protection for the Interior of Steel Water Tanks
D110	Wire- and Strand-Wound, Circular, Pre-stressed Concrete Water Tanks
D115	Tendon-Pre-stressed Concrete Water Tanks
D120	Thermosetting Fiberglass-Reinforced Plastic Tanks
D130	Flexible-Membrane Materials for Potable Water Applications

Table 5-3 lists relevant AWWA design manuals for water supply practice. The list is not comprehensive. Removed for Security The manuals most frequently used by SPU are M11 (Steel Pipe Design), M41 (Ductile Iron Pipe Design), and M22 (Sizing Water Service Lines and Meters).

Table 5-3
AWWA Design Manuals for Water Supply Practice

Designation	Title
M1	Principles of Water Rates, Fees and Charges
M2	Instrumentation and Control
M3	Safety Practices for Water Utilities
M4	Water Fluoridation Principles and Practices

Designation	Title
M5	Water Utility Management
M6	Water Meters: Selection, Installation, Testing, and Maintenance
M7	Problem Organisms in Water: Identification and Treatment
M9	Concrete Pressure Pipe
M11	Steel Water Pipe: A Guide for Design and Installation
M12	Simplified Procedures for Water Examination
M14	Recommended Practice for Backflow Prevention and Cross-Connection Control
M17	Installation, Field Testing, and Maintenance of Fire Hydrants
M19	Emergency Planning for Water Utilities
M20	Water Chlorination/Chloramination Practices and Principles
M22	Sizing Water Service Lines and Meters
M23	PVC Pipe Design & Installation
M25	Flexible-Membrane Covers and Linings for Potable-Water Reservoirs
M27	External Corrosion: Introduction to Chemistry and Control
M28	Rehabilitation of Water Mains
M29	Water Utility Capital Financing
M31	Distribution System Requirements for Fire Protection
M32	Computer Modeling of Water Distribution Systems
M33	Flow meters in Water Supply
M36	Water Audits and Leak Detection
M41	Ductile Iron Pipe Fittings
M42	Steel Water-Storage Tanks
M44	Distribution Valves: Selection, Installation, Field Testing, and Maintenance
M48	Waterborne Pathogens
M49	Butterfly Valves: Torque, Head Loss, and Cavitation Analysis
M51	Air-Release, Air/Vacuum, and Combination Air Valves
M52	Water Conservation Programs-- Planning Manual
M55	PE Pipe--Design and Installation

Acronyms and Abbreviations

DI: ductile iron

PE: polyethylene

PVC: polyvinyl chloride

5.3.2 Regulations

All water facilities must be built to the applicable City, King County, Washington State, and federal requirements.

5.3.2.1 City Standards

The City Standard Specifications and Plans are available online or from the Engineering Records Vault. The sections that apply specifically to water systems are Standard Specifications sections 7-11 through 7-15 and section 9-30 and Standard Plans Section 300. These standards are primarily based on AWWA industry standards.

5.3.2.2 City Ordinances

The City has a number of [ordinances pertaining to the water system](#).

5.3.2.3 King County

All water system works are subject to the provisions and requirements of [Title 12 of the King County Board of Health Code](#).

5.3.2.4 Washington State Department of Health

DOH is the regulatory agency that ensures that water systems comply with system capacity requirements of the federal Safe Drinking Water Act (SDWA). Authority to regulate the public water supply system is granted under [Washington Administrative Code \(WAC\), Chapter 246-290 Public Water Supplies](#), also known as the Public Water System Rule. A key term under the rule is *system capacity*, which is defined as having the technical, managerial, and financial capacity to achieve and remain in compliance with all applicable local, state, and federal regulations.

A. Water System Plan

The public water system rule ([WAC 246-290](#)) includes the Washington State Legislature-approved Municipal Water Law and the federal law, Long Term 2 Enhanced Surface Water Treatment Rule. DOH requires water purveyors to submit a Water System Plan to ensure water quality and protection of public health ([WAC 246-290-100](#) and [WAC 246-291-140](#), respectively). SPU's [Water System Plan](#) was last updated in 2019.

Water systems plans are typically updated every six years. If a purveyor installs distribution lines or makes other improvements and the project requires State Environmental Protection Act (SEPA) analysis, a water system plan amendment is required (WAC 246-03-030[3][a]) before construction.

B. Water System Design Manual

The [Washington State DOH Water System Design Manual](#) (2019) provides guidelines and criteria for design engineers to use for preparing plans and specifications for Group A water systems, such as SPU, to comply with the Group A Public Water Supplies ([Chapter 246-290-WAC](#)). **This manual delineates mandatory requirements of the WAC that must be adhered to by SPU.** Design engineers may use design approaches other than those in this manual if they do not conflict with [Chapter 246-290 WAC](#). DOH will expect the design engineer to justify the alternate approach used and the criteria that apply.

5.3.2.5 Other

Recommended Standards for Water Works (10-States Standards) – Part 7, Finished Water Storage is a source for water storage design.

5.3.2.6 Federal Safe Drinking Water Act

The [SDWA](#) protects public health by regulating the nation's public drinking water supply. The law requires many actions to protect drinking water and its sources. SDWA does not regulate private wells that serve fewer than 25 individuals. SDWA authorizes the U.S. Environmental Protection Agency (EPA) to set national health-based standards for drinking water to protect against both naturally occurring and human-made contaminants.

5.4 BASIS OF DESIGN

The basis of design (BOD) documentation (both the BOD plan sheet and BOD report) communicates design intent primarily to plan reviewers and future users of a constructed facility. By documenting the BOD and archiving it with project record drawings, future staff will have a better understanding of the design decisions.

See [DSG Chapter 1, Design Process](#) for requirements.

5.4.1 Basis of Design Report

A template for the BOD report is provided in [DSG Chapter 1, Design Process](#).

For water main projects, Table 5-4 lists the design criteria that should be included in the BOD report for a typical distribution main project. Note that the design criteria will require more elements for a transmission main or a water facility project.

Table 5-4
Design Criteria List for a Typical Water Distribution Main Design (Example)

Description	Design Criterion/Design Data
Pipe Materials:	
Length	1,360 LF
Diameter	8-IN
Material	DI CL 52
Joints	Restrained Joint. Note that all joints for WMWRP6 will be restrained due to similar pricing to push-on Joint.
Lining	Double thick cement-mortar per standard specifications.
Corrosion Protection	Polyethylene encasement – project is in mildly corrosive soils.
Pressure Rating	300 psi test
Pipe Location:	
Alignment	15-FT E of C/L

Description	Design Criterion/Design Data
Spacing and Clearance	6-FT from EX 2-IN WM
Utility Conflicts	None
System Connections	Connect to EX 8-IN WM north of NE 55 th St
Appurtenances:	
Line Valves	No mid-block line valves
District Valves	None
Fire Hydrants	No mid-block hydrants
Blowoff Valves/Drains	None
Combination Air-Vacuum and Air Release Valves	None
Street Restoration:	
Pavement	Concrete panels to be replaced with 8-IN Roadway Cement Concrete per Std Plan 401A.
Curbs	Type 410C
Trees	Existing trees to be protected. Utility trenching will be within the dripline of some trees. Work must follow tree protection notes.
Traffic Calming	Traffic circles to be replaced at NE 59 th St and NE 56 th St.
Impacts to ROW Structures	None
Curb Ramps	NE 60 th St: Expect 8 ramps to be installed.
Drainage	Replace inlet and inlet pipe if the entire inlet pipe is within new pavement or if able to connect to existing inlet pipe within triggered panel. Else, replace grate only.
Construction Considerations:	
Shutdowns	A total of 5 shutdowns are required. See Construction Sequencing Plan in Special Provisions.
Temporary Water	No temp water main proposed although this will be looked at in later design stages with SPU crews to determine if it would be beneficial to reduce shutdown times
Other Agency Project Coordination	No projects shown in dotMaps.
Critical Facilities	No nearby hospitals or schools within shutdown area.

5.4.2 Basis of Design Plan Sheet

A template for the BOD plan sheet is provided in [DSG Chapter 1, Design Process](#).

For water main projects, Figure 5-3 is a representative list of the kinds of information to include in the BOD plan sheet for a distribution main project. Not all topics shown will be on every BOD sheet and some projects will have additional design or operational parameters that should be included.

Figure 5-3
Basis of Design Plan Sheet Data for Water Infrastructure (Example)

Basis of Design Criteria		NW 201st St
PRESSURE ZONE(S)	(FT)	480
GROUND SURFACE ELEVATION	MAX (FT)	278
	MIN (FT)	278
WORKING PRESSURE	MAX (PSI)	87
	MIN (PSI)	87
SURGE PRESSURE	MAX (PSI)	132
	MIN (PSI)	132
PIPE MATERIAL	DIAMETER (IN)	6 & 4
	MATERIAL	D1
	CLASS	52
	JOINTS	RESTRAINED MECHANICAL JOINT
	COVER (FT)	
BEDDING COMPACTION	ROADWAY/NON-ROADWAY	BOTH
	BEDDING CONSTANT	
	MODULUS OF SOIL REACTION (E')	
	COMPACTION	
APPURTENANCES	ISOLATION VALVES	---
	DISTRICT VALVES	---
	BLOW OFF VALVES/DRAINS	---
	LINE VALVES	1 - 12-IN, 2 - 6-IN, 2 - 4-IN
	AIR-VACUUM/AIR RELEASE VALVES	
	OTHER	1 - 3-IN PRV, 1 - 6-IN PRV
CORROSION PROTECTION	SOIL CORROSIVITY	MILDLY-CORROSIVE
	CORROSION PROTECTION	CL B SAND BEDDING, POLYETHYLENE ENCASEMENT

5.5 DESIGN PROCESS

See [DSG Chapter 1, Design Process](#). The design process for water infrastructure does not differ from that described in Chapter 1.

5.6 DISTRIBUTION AND FEEDER MAIN DESIGN

5.6.1 Modeling and Main Sizing

5.6.1.1 Minimum Pipe Size

The standard water distribution main size is:

- 8-inch diameter pipe for most residential areas
- 12-inch diameter pipe for industrial and commercial areas

Exceptions to the minimum pipe size must be approved by SPU Water Planning & Program Management.

5.6.1.2 Determination

SPU Water Planning & Program Management (WPPM) maintains the models of the water distribution and transmission system and works with SPU engineering on modeling analyses. WPPM will determine the size for a new or replaced water main.

When designing a water main that is 12 inches or larger in diameter, a hydraulic network modeling analysis should be completed. The modeling analysis will determine the capacity of the main to provide peak hourly demand and fire flow. In some cases, field hydrant flow tests will be required to verify modeling results.

5.6.1.3 Maximum and Minimum System Pressure

SPU Policy on Distribution System Water Service Pressure (SPU-RM-006) establishes SPU's pressure standards. Minimum pressure criteria for new water mains are 30 psi under peak hour demand (PHD) conditions, and 20 psi when flows are a combination of average maximum day demand (MDD) and required fire flow. **Pressure at the customer's meter must not be less than 20 psi.** Pressures within distribution mains are not limited to a set maximum. All new services with static pressure above 80 psi require a PR valve per plumbing code requirements. When increasing a pressure zone's maximum pressure, account for existing customer aged piping, appurtenances, and fixtures. At a minimum, affected customers should be notified and included in project design at an early stage.

5.6.1.4 Fire Flow Rate and Duration

The City, City of Shoreline, and King County have adopted the International Fire Code (IFC). Site-specific fire flow requirements as determined by the appropriate Fire Marshall are used when issuing Water Availability Certificates and sizing of new water mains.

5.6.2 Location

5.6.2.1 Standard Location

Distribution mains are typically [located within the right-of-way \(ROW\)](#) in a standard location at a standard depth. See Standard Plan 030. Standard locations allow Operations to predictably access the mains while keeping the ROW corridors available to all utilities.

SPU may install or allow installation of water mains in private streets or easements. Location of the mains is determined case-by-case within easements of 20 ft or less in width. SPU does not allow building of structures over water mains without obtaining project-specific concessions from the structure owner, such as putting the pipe in a casing, operations and maintenance (O&M) easements, and round-the-clock access. These concessions are recorded in the official City records.

Often, space may not be available to locate the water main in the standard location due to required clearances from existing utilities. Other controlling factors such as continuous water service may require that an existing water main be kept in service while a new main is installed in a non-standard location. An alternative to keeping existing water mains in service during construction is the installation of temporary water mains with connections to the affected services and hydrants. This can be an expensive option; cost is usually estimated by Field Crews Planning and Scheduling.

5.6.2.2 Extent of Water Main Projects

Water service reliability and fire flow sufficiency in the distribution system depend on connectivity (or “gridding”) of individual water mains occupying various street ROWs. Water mains are often constructed or upgraded incrementally. **The full extent of an individual new or upgraded water main project must allow for grid connectivity for future adjacent projects and/or complete grid connectivity previously provided by past adjacent projects.** Specifically:

- When a new or replacement water main installation is designed or required to extend to within 50 ft of the perimeter of any City ROW intersection, the project must extend the water main to the near edge of that intersection.
- When a new or replacement water main installation is designed or required to extend to the edge of any City ROW intersection, the project must extend the water main into and/or across that intersection to connect to all existing water mains placed within 10 ft of the intersection polygon. If approved plans exist for a new or replacement water main installation extending to within 10 ft of an intersection polygon, the newly designed water main is considered to be existing for the purposes of this guideline provision.
- When a new or replacement water main installation is designed/required to pass through any part of a City ROW intersection, the project should strongly consider installing water main lateral “stubs” to facilitate gridding with future water mains installed in adjacent streets.
- When a new or replacement water main project reaches its designed or required end point and an existing water main occupies the same half of the street as the new/replacement water main, the project must connect the existing water main to the new/replacement main. Further, if the existing water main consists of galvanized iron pipe, the project must replace a sufficient portion of the existing galvanized iron pipe with Type K copper pipe to eliminate galvanized iron pipe within a 10-ft radius of the end point of the new/replacement water main.

5.6.2.3 Pipe Cover

Depths of cover for water mains are shown on Standard Plan No. 030. The depths vary depending on size of pipe. Required cover over gate valves (GVs) often dictate minimum main cover. Mains larger than 12 inches in diameter typically use butterfly valves (BFVs). BFVs require less cover due to their shape and allow large mains to be buried at shallower depths. Generally,

SPU attempts to bury the pipes as shallow as feasible for ease of installation and maintenance. As noted in the standard plan, standard depth of cover is not less than 35 inches. However, in special cases like crossing other utilities, such as high-pressure gas mains, large diameter sewers, or underground structures (e.g., electrical and telephone duct banks), may require a localized shallower crossing. Minimum allowable cover over all water mains without specially designed structural support and backfill is 30 inches. Valves may not be placed in shallower cover locations. Typically, the depth to the pipe invert should be kept to less than 6 ft, if possible, to reduce the need and cost for excavation and shoring.

When the pipe diameter reaches 30-inches and larger, especially for thin-walled steel pipe with a diameter/thickness ratio of 80 or higher, consider setting the depth of cover at 4ft. The deeper pipe receives better soil support at the sides to limit vertical deflection, has lower live loading impacts, and has additional cover to enable use of larger chambers needed for valves, and other appurtenances like large combination air valves (CAVs).

5.6.2.4 Clearances

Standard horizontal and vertical separations may not always be feasible in highly developed urban corridors. Special construction methods can be used to provide equivalent levels of protection to the standard separation criteria. Separation distances to provide structurally sound installations depend on the available working space for construction and soils and groundwater conditions at the site.

Clearance requirements between water mains and other utilities can be found in City Standard Specifications section 1-07.17(2)A and are summarized in Table 5-5.

Table 5-5 Clearances to Water Mains

Condition	Horizontal Clearance	Vertical Clearance
Ductile iron water main	5 feet	18 inches
Cast iron water main	10 feet	18 inches

Except for gas utilities, when circumstances do not permit the standard required minimum clearance on ductile iron water mains, plastic foam (Ethafoam) per Standard Specifications section 9-30.2(9) is used to fill spaces 6 inches and smaller between the water main and the crossing utility. However, plastic foam **is not** used on cast iron pipe because cast iron pipe is brittle and must be fully supported.

The required 5-ft horizontal separation for lateral clearance to parallel utilities is intended to provide space to allow water services to be tapped on the water main. Less than 5 ft of separation is insufficient for creating water service taps.

A. Overhead Utilities

See [DSG Chapter 3, Design for Construction](#).

B. Gas

When gas mains are in the project installation zone, note the gas main pressure. Table 5-6 summarizes the clearance requirements from [Standard Specifications section 1-07.17\(2\)D](#).

Table 5-6 Required Gas Main Clearances

Type of Gas Main	Requirements
High pressure	<ul style="list-style-type: none"> • Horizontal clearance must be at least 3 feet. • Vertical clearance must be at least 3 feet.
Non high pressure except gas transmission line	<ul style="list-style-type: none"> • Horizontal clearance must be at least 1 foot. • Vertical clearance must be at least 6 inches.

If work is adjacent to a high-pressure gas main, the vertical clearance can result in very deep-water main installations. In such cases, the designer can contact the gas utility and request a review to use a split polyvinyl chloride (PVC) casing around either the gas main or the water main. This may decrease the required vertical separation over or under the high-pressure gas main to 1-ft. Split PVC casings usually extend 3 to 6 ft beyond both sides of the crossing location. Ask the gas utility for specifics required.

For non-high-pressure gas mains, the absolute minimum parallel clearance is 1 ft, which is typically found on gas and water service laterals. Any clearance below 5 ft on parallel gas and water mains complicates tapping water services, if not impossible. **Non-high-pressure water mains must meet the vertical crossing minimum clearance of 6 inches, as described above.**

C. Buried Electrical and Communications Duct Banks

Buried electrical or communications duct banks are typically, though not always, located at lower depths than water mains. **Parallel duct banks should have a 5-ft clearance between the bank and a water main, to allow placement of taps and valves for new service connections.**

Crossing duct banks should clear the water main by 1 ft. During construction of duct banks, there is a tendency to provide less than the 1 ft vertical clearance requirement. Some SPU water mains have even been encased in crossing electrical duct banks, which is not allowed under any circumstance. A possible method of preventing close duct banks is to require the water main at the crossing to be wrapped with 6 inches of plastic foam prior to placement of the duct bank concrete or Fluidized Thermal Backfill (FTB).

D. Sewer and Stormwater

Sewer and Stormwater are both considered non-potable water sources and both require the standard separation requirements specified in [City Standard Specifications section 1-07.17\(2\)A1 and Standard Plans 286A and 286B](#). In fact, potable water that has passed an air gap is considered non-potable and falls under the separation requirement. Separation requirements for air gap discharge chambers are discussed in DSG section 5.6.5.3.

Where standard sewer, storm, and water pipeline separations cannot be achieved, an engineered design must be developed for adequate cross connection control. DOH and the Washington State Department of Ecology (Ecology) jointly publish the [Pipeline Separation Design and Installation Reference Guide](#). The design engineer should consider the contents of this guide while designing water utility separations from other utilities whenever standard SPU criteria are not feasible.

E. Tree Clearances

The current inter-departmental agreement on tree clearances from water mains is a minimum of 5 ft from the edge of the water main to the edge of the tree. When placing new water mains in non-standard locations and through tree-lined and canopied streets, follow Standard Plan 133.

See [DSG Chapter 3, Design for Construction](#).

F. Thrust Blocking

Concrete thrust blocking relies on the soil passive earth pressure. Design thrust blocking to avoid placing the fitting's resultant thrust vector across sewers, storm drains, and other utilities or towards a chamber or maintenance hole. The clearance required for these situations is 10 ft or more for 8-inch and smaller water mains and 12-ft for 12-inch water mains. If a low strength soil exists in the project location or the backfill is not placed to 95% of the Modified Proctor Test, the soil's internal friction angle could be approximated between 20° and 30°. With the bottom of an 8-inch fitting's thrust block at approximately 4 ft below ground surface, the wedge of soil resistance surfaces near 10 ft behind the back face of the concrete block. Similarly, for deeper 12-inch water mains, the bottom of the block may be near 5 ft below ground surface and require 12-ft separation from other utilities and structures.

SPU avoids aligning bend, fitting, and closed valve thrust vectors towards sewers and storm lines because, when trenching is needed to replace or perform maintenance, the thrust would be against the trench opening.

5.6.3 Materials

This section describes standard materials used in SPU water distribution system projects.

5.6.3.1 Pipe Materials

All new or replaced water pipe must meet the standard material types shown in Table 5-7.

PVC pipe may be allowed in corrosive soil areas. High-density polyethylene (HDPE) pipe may not be used as a standard material for permanent installations. Temporary HDPE piping has been used on several projects on a case-by-case basis. SPU is currently evaluating the use of HDPE pipe. This chapter will be updated if HDPE becomes acceptable to use as a standard pipe material.

Water mains must be designed to withstand both test pressure according to [Standard Specifications section 7-11.3\(11\)A](#) and external loads. Test pressure is measured at the downhill end of the pipe run.

Most distribution lines serve a portion of the City and are within a designated pressure zone. In cases where there is an **extreme** pressure differential (e.g., downhill pipeline), the pressure rating of the pipe should be checked along the pipeline route against the operating pressure consisting of the maximum expected system zone pressure plus a surge pressure allowance. Excessive operating pressure over the pipe and fitting pressure classification would indicate that a higher pressure rated pipe should be used and/or install a PR valve to reduce the pressure. See DSG Section 5.6.5.1A. Before considering installation of a PR valve, the design engineer should coordinate with WPPM to ensure the PR valve will not negatively affect the system.

**Table 5-7
Standard Materials for SPU Distribution and Feeder Mains**

Structure	Material
Pipe	<ul style="list-style-type: none"> • <u>2-inch diameter pipe (when allowed by SPU) must be Type K copper.</u> • 4-inch to 12-inch diameter pipe should be ductile iron pipe, class 52 or thicker with double thick cement mortar lining. • 4-in to 12-inch diameter pipe can be polyvinyl chloride (PVC) DR14 on a case-by-case basis in corrosive soil areas. • <u>Feeder mains larger than 12-inch diameter must be either ductile iron or steel.</u> • SPU is evaluating the use of high-density polyethylene (HDPE) DR11 pipe. It is not currently an accepted standard pipe material. If proposed for a project, HDPE should be evaluated for suitability, including vetting through Operations personnel. <u>Authorization to use must be granted by the Water LOB and be accepted by the Washington State Department of Health (DOH).</u>
Bends and Fittings	<ul style="list-style-type: none"> • Typically, bends and fittings should be the same material as the pipeline. • <u>Fittings for 2-inch copper pipe must be brass with either flared or compression joints.</u>
Joints	<ul style="list-style-type: none"> • Typically, ductile iron pipe is joined by a non-restrained bell and spigot joint, also called a slip joint (SJ), Tyton, or push-on joint where there is room for thrust blocking and where soil deformation, regardless of cause, is determined to be unlikely. • Joints for ductile iron water mains also include restrained joint (RJ), mechanical joint (MJ), and earthquake-resistant joints that meet the ISO 16134 (Earthquake – and Subsidence – Resilient Design of Ductile Iron Pipelines) Table 2, Class S-1, A and M-2 performance criteria. • Welded joints on steel pipe should conform to American Welding Society (AWS) D1.1 Structural Welding Code, Section 3, Workmanship. Butt-welded joints are used for earthquake backbone piping systems. Welded lap joints are suitable where soil deformation, regardless of cause, is determined to be unlikely. • Sleeves and mechanical couplings are connection fittings that join two plain end pipes. Sleeves are typically cast from ductile iron. SPU requires sleeves to have a long body style and have MJ ends. Mechanical couplings are typically fabricated from steel and <u>must have a long body pattern per City Standard Specifications section 9-30.2(6), middle ring, and two end rings that squeeze sealing O-ring gaskets into flared ends on both sides of the middle ring.</u> This style of joint is recognizable by the multiple tie rods parallel to the joint and that squeeze the end rings into the gaskets. Sleeves are used for ductile iron pipe to ductile iron pipe joints and ductile iron pipe to cast iron pipe joints. Mechanical couplings are used primarily when connecting steel pipes and when steel pipe is joined to ductile iron pipe or cast-iron pipe. When steel pipe is connected to ductile iron pipe and cast-iron pipe, a thin rubber boot is placed over the plain cast iron pipe or ductile iron pipe end to insulate the connection. Corrosion control measures are installed after the connection is completed.
Casing	<ul style="list-style-type: none"> • See DSG section 5.1.1. • Whether installed above grade or below-grade, casing pipe must be smooth steel, with the diameter and wall thickness specified in the drawings. <u>Casings made up of multiple pipe sections must be continuous and butt-welded at joints to provide a uniform surface for casing spacers to slide across.</u> • <u>All joints must be welded by qualified operators.</u> Steel casing pipe is discussed in <u>Standard Specifications section 9-30.2.</u> • <u>Casing seals and spacers must be per Standard Specifications section 9-30(15).</u> • The annular space between the casing and the carrier pipe outside diameter (OD) is normally left unfilled. SPU typically seals the ends of the casings but does not fill them. This allows the carrier pipe to be replaced inside the casing with minimal disruption to the site and ensures that stresses from casing deformation are not directly transferred to the carrier pipe. Rarely, if specified in the contract, the space between the carrier pipe and casing pipe may be filled with sand, grout, or some other material due to

Structure	Material
	specific design criteria for the project. <u>This design criteria must be included in the project design criteria and BOD plan sheet.</u>

5.6.3.2 Bedding and Backfill

The design engineer should require sand bedding for water mains unless another City agency dictates otherwise. Sand bedding creates a less corrosive environment around a pipe than does native soil. Sand bedding also eliminates point loads on the pipe caused by stray rocks. Sand bedding is typically Class B, Sand Mineral Aggregate Type 6 or 7 unless otherwise specified. (Type 9 is used for transmission mains.) [See Standard Plan 350 for information on water main trench and bedding and Standard Specifications section 9-03.16](#) for a mineral aggregate chart.

Backfill is either suitable native material, Mineral Aggregate Type 17 when native material is not suitable for backfill, or other material as approved by the design engineer. For suitable native backfill material, see Standard Specifications section 7-10.3(10) for requirements. For requirements for Mineral Aggregate Type 17, see Standard Specifications section 9-03.16.

For more information on bedding and backfill, see [Standard Specifications sections 7-10.3\(9\), 9-03.12\(3\), and 9-03.16](#).

A. Standard Trench Section

For requirements for a standard trench section, see Standard Plan 350.

B. Controlled Density Fill

Sometimes an outside agency, time constraints, or compaction difficulty will require that a water main be bedded and backfilled in controlled density fill (CDF). **When this requirement outweighs the benefit of using sand bedding, a metallic water main must be protected where it is embedded in CDF. The protection must extend from trench wall to trench wall.** SPU uses two layers of polyethylene encasement (See Standard Specifications section 9-30.4[12]) around the main to keep it separated from the CDF (Figure 5-4). The PE encasement is carefully pressed into the soil interface at the trench walls and secured in place with wide adhesive tape or wax tape to ensure the entire metallic pipe is covered and to exclude the CDF from contacting the pipe.

When CDF is used near the metallic pipe, a corrosion specialist should be consulted because CDF can create a galvanic corrosion cell.

The CDF used to encase the water main must be a hand-diggable CDF mix. All CDF should be ½ sack mix, less than 200 psi, and preferably less than 100 psi. SPU has approved various types and uses of CDF. CDF can be used as a trench plug, trench backfill, or for grouting an annular space. Each use has a different mix ratio. The design engineer should refer to the City Standard Plans and Specifications for each CDF use. See Standard Specifications section 9-01.5.

When CDF is used to fill pipe and the annular space between two pipes, it must have no more than 100 psi strength at 28 days. See Standard Specifications section 9-05.15.

Figure 5-4
Controlled Density Fill

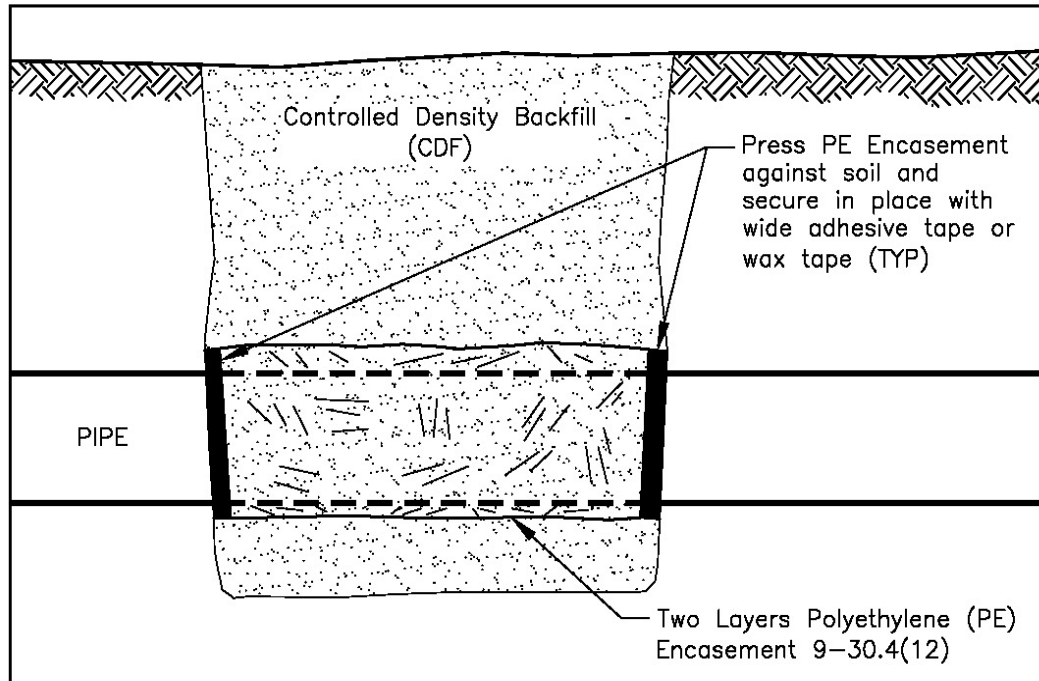

5.6.3.3 Thrust Restraint

This section describes the types of thrust restraints used in the SPU water distribution system. Typically, ductile iron pipe is joined by a non-restrained bell and spigot joint, also called a Tyton or push-on joint. Some steel pipe is also joined in this manner. Thrust blocks are the SPU standard for restraining pipe when non-restrained bell and spigot joints are used. The design engineer should use Standard Plans 330a, 330b, 331a, and 331b and the AWWA Manual M41 to design thrust blocks. Some situations will not allow space for concrete thrust blocks. In those situations, use pipe with built-in RJs, or a cantilevered pile thrust restraint system designed for the specific situation.

A. Concrete Blocking

Concrete thrust blocks are the most common thrust restraint in the SPU system. Thrust blocking relies on the surface area of the block being in contact with undisturbed soil to counteract the pressure acting on the pipeline fitting. Soil conditions may require a pile-supported thrust block if the concrete block is located in, or over, liquefiable soils to prevent the block from sinking. The soil conditions are a very important factor in concrete thrust block design.

In concrete thrust block design, the following should be considered:

- Avoid excavations or disturbance of soils behind thrust blocks.
- Avoid directing thrust toward other utilities, utility maintenance holes or chambers within 10 ft for water mains less than 12 inches in diameter and within 12 ft for water mains that are 12 inches or larger in diameter.

- Where the construction site has poor soil strength, loose soils, or disturbed soils, the area behind thrust blocks should be replaced by a densely compactable granular fill containing mineral aggregate with angular and fractured faces, such as Mineral Aggregates 1, 1G, 2, 2G, 21, and 22.
- During design, consider future disturbance of thrust blocks. For example, the downtown business district has a high probability of future disturbance, while residential streets are less likely to require excavation behind blocks.
- If space is limited or utility congestion is high, consider using a restrained pipe joint system through the congested area and provide concrete blocking where there is less congestion or where the new water main joins the existing unrestrained water main.
- Standard Plans 330a–b and 331a–b are for 12-inch pipe and smaller. Piping larger than 12 inches must have blocking designed for the situation.

1) Horizontal Thrust Block

Horizontal thrust block sizing calculation should follow either [Standard Plan 331 or AWWA Manual M-41](#).

2) Vertical Thrust Block

In some cases, vertical thrust blocks may be needed. Vertical thrust blocks for pipe 12-inches and smaller should follow Standard Plan 330. For pipe larger than 12-inches the design must be prepared under the direction of a professional engineer.

Note: Vertical 90° bends are not practical unless in a chamber using joint restraint systems or constructed of welded steel. There is no standard method to block a vertical 90° bend.

B. Concrete Thrust Collars

Concrete thrust collars are occasionally used as a method of thrust restraint. Typically, thrust collars are used to restrain large valves in chambers and valves near casings or connections to existing pipe. Collar refers to the section of concrete formed around the pipe to counteract thrust forces. Collars withstand thrust force by both passive soil pressure and friction on the bottom surface of the block. To keep the pipe from sliding within the collar, the concrete needs to interface with the pipe.

1) Steel Pipe

If using concrete collars on a steel pipe, a thrust ring may be factory installed or field welded around a pipe section. This design should be thought out to make sure that the interior of the pipe lining is not damaged due to the high heat from welding before the pipe is put in service. Alternatively, provide a method to repair the lining after the welded thrust ring is completed (e.g., installing an access port near the thrust ring or arranging for internal pipe inspection and lining repair by entering the pipe).

Some existing steel pipes are lined with coal tar enamel. When field-welding thrust rings to this pipe while in service, the coal tar will melt and off-gas noxious vapors into the water being served to customers. To prevent this, in 2020, SPU began researching the

use of multiple thrust rings attached with a very stable, very high shear strength epoxy bond, such as a Belzona product. The combined factor of safety for the epoxy-bonded system is currently considering a value between 4 to 8 depending on thrust load, soils, criticality of the main, confidence level of the bonded system to perform as needed, temperature during application, ability to properly prepare the pipe surface and keep it dry, and the level of experienced workmanship.

2) Ductile Iron Pipe

If using concrete collars on ductile iron pipe, the preferred method is to have a factory-fabricated thrust ring installed on the pipe section. In place of a thrust-ring assembly, install two WRGs with their mechanical joint (MJ) gasket compression surfaces facing each other and the wedge tightening nuts facing away from the center of the collar. Encase these two WRGs in a reinforced concrete collar. Concrete-encased WRGs must always be wrapped in polyethylene before placing the collar reinforcing steel. This prevents the cast-in-place concrete from seeping into the restraining wedges and thus hinders the wedges' ability to grip the pipe barrel.

3) Poor Soil Conditions

Design should consider the potential settlement impact the concrete thrust collar could have on the pipe. Settlement mitigation methods include supporting thrust collars on piles, improving the soil below and around the pipe and collar, and placing a thick layer of quarry spalls wrapped in geotextile for separation or soil stabilization below the thrust collar (see [Standard Specifications section 9-37.2](#), Table 3).

C. Pipe Anchors/Tie Backs

Pipe anchors consist of a large mass of concrete usually on one side of a pipeline. The concrete is attached to the pipeline by steel rods. Anchors act like vertical thrust blocks (except in a horizontal plane) to restrain the pipe at a bend. Typically, pipe anchors are only installed for temporary service because the rods can corrode.

D. Rigid Restrained Joints

Flanges, welded joints, and threaded couplings are types of rigid RJs. Flanges can be used on both ductile iron and steel pipes. SPU does not use threaded couplings in water mains.

I) Flanges

SPU does not recommend burying flanges in soil. Flanged fittings are used where joint flexibility is not needed and are typically found in vaults associated with valves or other appurtenances. Flanged pipe must be perfectly aligned to form a leak-free joint, and it offers no flexibility for post-installation ground or structure movement. A dismantling joint must be used to allow disassembly and repairs. Flanged valves are usually used within the installation of a large run of flexible RJ pipe. Each flanged valve will have a short flange by flexible RJ adapter on each side of it.

An electrical insulating flange kit (Standard Specifications section 9-30.2[5]B) is usually necessary when joining a steel pipeline flange to a ductile iron appurtenance flange. Steel and ductile iron are dissimilar materials that can corrode if they are mechanically and electrically in contact with each other. Where flanged valves and fittings are inside a

valve chamber and are bolted to steel pipe flanges, insulating flange kits are not normally required. The chamber provides the ability to inspect the pipe and fitting condition. In this case, a corrosion protection joint bonding cable is welded to the steel pipe on both sides of the ductile iron components. This acts as an electrical jumper to maintain electrical continuity in the steel pipe. However, if a ductile iron pipe water main, hydrant lateral, or water service lateral is connected to a steel pipe, whether inside or outside a chamber, an insulating flange kit is nearly always required.

Encase flanged connections in three layers of wax tape coating per City Standard [Specifications sections 9-30.1\(4\)F and 7-11.3\(8\)A](#).

2) Welded Joints

Steel pipe can be assembled with welded joints, making the pipeline fully restrained. Field-welded joints provide restraint against the unbalanced hydrostatic and hydrodynamic forces acting on the pipe, as well as temperature-induced pipe stress and soil movements. There are several styles of welded joints. The most common are the lap-weld, butt-weld, and butt strap joints. Refer to AWWA Manual M-11 for a photo of each type of joint:

- **Lap-weld joint.** In general, SPU prefers a lap-weld joint because they are easy to install. Lap-welded pipe is a bell and spigot connection with the bell welded to the spigot where they overlap. The design engineer can select an interior-only weld, exterior-only weld, or double lap weld (interior and exterior). SPU recommends the double lap weld. A double lap weld provides an added safety factor at each joint but can only be applied to larger diameter pipe because it requires the welder to enter the pipe to make an interior weld. With double-lap welds, each joint can also be checked for leakage with an air test. With a lap weld joint, small deflections can be made at each joint before welding. Given the geometry of the double welded lap joint, it experiences twice as much strain as the pipe wall when post-construction forces (i.e., settlement, thermally induced) cause pipe movement.
- **Butt-weld joint.** Butt-weld joints are made by aligning the ends of two pipe sections and welding at the point of near-contact of the two ends. To complete a butt-weld joint, both ends of pipe to be joined should be nearly identical in size. A butt-weld joint is more difficult to complete in the field because the pipes must be near perfectly aligned. This style weld eliminates the geometric strain that can be induced at a lap-weld joint due to non-colinear forces resulting from temperature-induced strain and ground movement. SPU has used butt-welded joints for pipelines designed for higher levels of seismic loading. The butt-weld joint is also used in horizontal directional drilling (HDD) applications, where having a bell shape on the pipe is not preferred. A full penetration butt-welded steel pipe is one of the best choices for seismic protection. In tight field conditions, a single-sided full penetration joint may be used. A backer is used for this weld, and the backer must be removed after the weld is complete. If access to the pipe interior is possible, a double-sided full penetration butt weld may be installed.
- **Butt-strap joint.** A butt-strap joint consists of two half-circle strips of steel that overlap two plain end pieces of pipe by 2 or more inches on each joining pipe.

There is typically a space of 2 to 4 inches between the mating pipe ends to allow for field adjustments on pipe 48 inches and smaller. The distance between pipe ends can be increased by more than 4 inches for larger diameter pipe to accommodate the space required when deflected joints at the connection location are needed. When accounting for longer spaces between pipe ends, consider the effect it will have on placement of cement mortar lining. Expanded metal made of plain steel may need to be tack welded to the inside of the butt strap joint to hold the cement mortar onto the pipe spring lines and crown of the pipe to hold it in place during placement and curing. The butt strap is joined to each pipe by an exterior structural weld designed to restrain all longitudinal loads and an interior seal weld. Both welds are full circumference fillet welds. The reason for using both interior and exterior welds is to ensure that the connection can be leak tested with low-pressure air and that water does not enter the uncoated space between the pipe and the butt strap, where corrosion may occur and not be inspectable. The two pipe ends do not require identical ODs, but they must be relatively similar. If the two pipes' ODs are not the same, a tapered butt strap can be fabricated to properly fit over each pipe end and would act as a very short reducer, with only a small diameter change. Typically, a butt-strap joint is used to join a new steel pipe to an existing steel pipeline.

In all cases, repair of the interior lining and exterior coating must be considered at welded joints. Heat-shrink sleeves that overlap adjacent intact pipe coatings by 10 inches to 12 inches on each side of the joint are often used to repair exterior coating.

For pipe smaller than 24 inches and for pipe installed vertically or on a very steep slope, consider how the lining will be repaired at the welded joint. For pipe smaller than 24 inches, an access port can be installed. The access port is a short flange-end welded steel outlet. The size should be designed large enough to permit access to make internal seal welds, restoration of the pipe lining, and inspection. Following a satisfactory joint completion, a blind flange is bolted to the outlet and the flange is wax tap coated.

Pipe smaller than 12 inches may not be suitable candidates for welded field joints due to the challenge of internal welding and repair of the lining. Even using only an external weld still leaves the internal lining to be repaired.

SPU follows the recommendations of the American Welding Society (AWS) Structural Welding Code.

E. Flexible Restrained Joints

Flexible RJs allow some deflection and movement of the joint but restrain the joint while under pressure. These joints are the standard RJs used by SPU and are specified in Standard Specifications section 9-30.2(3). All ductile iron pipe manufacturers make a boltless RJ ductile iron pipe that uses a restraining ring and locking lugs to restrain joints yet provide flexibility. Check the manufacturer's literature because products vary.

The use of flexible RJ pipe systems should be used when special site or system conditions are present and the use of concrete thrust blocks is not appropriate. Flexible RJ pipe systems are required when site/project needs have the following characteristics:

- The water main is to be located in an area of liquefiable soils.

- The area is defined to have soils with a poor bearing capacity.
- The area is on a steep slope. If the water main is to be in an area determined to be a slide area, earthquake-resistant ductile iron pipe (ERDIP) must be used. See DSG section 5.10 for details regarding seismic design.
- If the site is congested with underground utilities or other facilities such that concrete thrust blocks are unfeasible.
- To provide flexibility in shutdown areas and avoid using temporary thrust restraints.
- In areas where excavations, soil settlement or subsidence is anticipated, RJ pipe should be considered.
- If pipelines are critical to the functioning of the water supply system after a major seismic event, ERDIP must be used. See DSG section 5.10 for details regarding seismic design.

RJ pipe and fitting pressure ratings vary depending on fitting type and size. The pressure ratings should be verified with the manufacturer. The length of pipe in casings on any run of ductile iron pipe does not count towards its overall restraint length unless the casings are filled with grout after the pipe is installed. When using RJ pipe, all pipe in each individual system must be RJ. In addition to pipe joint restraint, it is SPU practice to install concrete thrust blocks unless site-specific conditions do not allow their use due to space limitations or other conflicts. Prior approval of the engineer of record is required before the thrust block is eliminated.

***Note:** Field cutting and modifying a factory-installed restrained pipe joint is difficult and time consuming and is not typically allowed without approval from the resident engineer. SPU only allows modifications to RJ pipe by factory-trained and certified personnel. Modifications to RJ pipe joints without following the factory specified procedures typically voids the pipe warrantee. Therefore, the pipe must be ordered to match the project-specific piping layout. Contractors must submit, and receive approval of, a lay plan showing both plan and profile before ordering RJ pipe.*

I) Wedge Restraint Glands

MJs are not RJs when standard MJ glands are used. An MJ gland is a ring around the ductile iron pipe that sandwiches and, when the bolts are tightened, compresses an MJ gasket between the bell and the pipe spigot to create a water-tight seal. MJs can be made into RJs by substituting a WRG for the standard MJ gland. When this is done, the joint can be referred to as an RMJ. WRGs can be used on MJ pipe and MJ bell fittings. They grip the pipe by forcing a set of hardened ductile iron lugs with teeth into the pipe barrel. Most wedge restraining systems remain flexible after installation. WRGs must follow [Standard Specifications section 9-30.4\(5\)B](#).

WRGs must **not** be used on cast iron pipe or fittings with plain ends.

Where two MJ bells face each other with a short length of ductile iron pipe between them, the design must allow space for assembling parts. The WRGs are typically placed onto the short piece of pipe that goes between the MJ bells and then the MJ gaskets are placed on the pipe ends. The design should allow at least 18 inches of space between

the bell faces, which means the short pipe lay length should be about 2 ft when the bell depth is considered.

Note: SPU has experienced some expensive failures due to inappropriate application of WRGs. Two significant situations must be avoided:

WRGs are not approved for use on plain end (PE) fittings. Ductile iron fittings go through a casting process that makes their outside surface much harder than ductile iron pipe. As a result, the restraining wedges do not bite into the surface of plain end fittings to the proper depth. While the initial testing of these joints might prove successful, over time, the joint may separate.

WRGs must not be used in applications where they are expected to resist rotation of the joint in addition to tensile pullout. If a rotating moment is applied to the joint, the restraint wedge teeth slide along the pipe with little resistance and allow the pipe to corkscrew out of the MJ bell. Therefore, all rotating moments must be properly blocked or otherwise restrained when WRGs are used.

2) Gasket Restraint

Restraining gaskets are similar to Tyton joint (or spigot joint) gaskets but they have stainless steel teeth imbedded in them that grip the pipe for restraint. Restraining gaskets are readily available and can be installed on field-cut, push-on joint pipe. Restraining gaskets are not truly flexible RJs. Once assembled, they offer little or no deflection capability. They also require special tools to disassemble and, as such, the pipe bells with restraining gaskets in them are usually removed if field modifications are needed. These gaskets are also quite expensive.

Note: SPU has used the restraint gaskets on occasion but found they do not save costs. The AWWA M41 Manual or DIPRA computer program can be used to calculate ductile iron pipe restraint requirements.

3) Grooved Restraint

Grooved restraint couplings can be used to restrain ductile iron and steel pipe and are available in rigid and flexible versions, though the flexibility is very limited. These couplings are uncommon in the SPU system but can be found on some blowoff facilities. Grooved restraint couplings are generally not used in buried service. Grooved restraints are best used inside buildings and chambers, in applications where they can be regularly inspected. Grooved restraint couplings can also be used with a rolled groove in thin wall steel pipe.

The standard grooved restraint coupling has a rubber gasket that covers both pipe ends and that is compressed under two or more coupling segments against the pipe's OD. The coupling segments have a lip that engages a groove that is cut into the exterior of the full circumference of the pipe. For this reason, an AWWA ductile iron pipe class thicker than SPU's standard CL 52 must be used for these couplings. A similar wide-bodied version of grooved couplings employs a welded ring on the plain ends of ductile iron and steel pipe instead of a groove in the pipe. The restraint is obtained by lips fabricated into the ends of the coupling bodies that engage the ring that is welded to the outside of the pipe. These couplings compress a pair of rubber O-rings on the pipes'

ODs and are custom designed for each project. These couplings can be ordered with some minor expansion and deflection capabilities and for customized pressure ranges. One manufacturer that SPU has used is Victaulic brand's Split Bolted Coupling.

Guidance regarding the design of RJ pipe systems without concrete blocking can be found on the [DIPRA](#) program's website.

F. Flexible Single-Ball Joints and Double-Ball Expansion Joints

For projects where extreme flexibility is needed, several manufacturers offer river crossing pipe that has restrained ball joints that provide high joint deflection capability.

Fittings are also available with similar ball joints that can be manufactured with one ball joint or two ball joints. In addition, these fittings can be manufactured with the capability for expansion-contraction from an initial set point. Some versions of these flexible-extension fittings can be manufactured to prevent internal forces from causing these fittings to expand to their maximum length when pressurized. Although this style of flexible-expansion fitting is expensive, their flexibility can be essential for connections between restrained piping and existing cast iron pipe systems or where earthquake ground displacements are expected adjacent to where pipe passes through structural walls.

The design engineer should use care when including flexible-extension fittings in the pipe system. Flexible-extension fittings can rotate, extend, contract, and adjust in any direction, yet will not separate. However, improperly installed flexible-extension fittings can expand unintentionally under pressure if the force-balanced type is not used. In RJ piping systems, this expansion force can collapse RJs and ERDIP joints, which are pulled out or preset during installation. To prevent this, the system should be designed to avoid unintended expansion. Thrust restraint collars may be required.

G. Connecting to the Existing System

In the SPU water system, most connections to existing (non-steel pipe) are unrestrained. A difference in outside diameters (ODs) of various materials can create a force imbalance at the connection similar to that of a reducer.

For example, a 100-year-old cast iron, 20-inch diameter water main could be ½-inch greater in OD than a new 20-inch diameter ductile iron main. **This force imbalance must be accounted for at the connection, especially if corrosion preventative isolation couplings are used to make the connection.** At 100 psi, this difference in OD creates a force imbalance of more than 3,000 lbs. in a 20-inch-diameter pipe connection. The connection coupling can be restrained by using tiebacks, wedge restraining glands (WRGs), or welded tabs on the smaller pipe, or some combination. The idea is to keep the connection coupling from sliding off the larger pipe and onto the smaller pipe due to the force imbalance.

Be careful with restraint for new valves near connections to existing pipe, especially when new RJ pipe is connected to unrestrained pipe. When closed and under pressure only from the existing side, the valve will tend to collapse the new flexible RJs and pull away from the unrestrained connection. This effect is usually overcome with a concrete thrust collar on the new pipe that is fixed rigidly to the new valve.

5.6.3.4 Casing

Water mains are installed in casings to protect the mains from excessive loads and to provide a means of replacing the pipe beneath structures such as railroad tracks. Casings also reduce the damage to facilities over the water main in the event of a leak or main break. Sometimes casings are required by other entities (e.g., railroads) where SPU utilities cross over or under them. Casings can be installed via open cut if there are no obstacles.

Casing materials must follow [Standard Specifications sections 9-30.2 \(14\) and 9-30.2\(15\)](#).

A. Jacked Casings

Casings installed under a railroad, river, or limited access freeway are often jacked into place. When designing jacked casings, adequate space is required for the casing and pipe jacking pit. Jacking pit size can vary depending on the lengths of casing or carrier pipe. RJ pipe must be used through the casing and beyond to a logical location to terminate the RJ pipe. Keep in mind that the cased length of pipe offers no thrust resistance via skin friction as does a buried pipe. Access must be provided for the existing pipe to be cut and connected to a new pipe.

Note: Jacking casing is dependent on pipe size. The larger the pipe size, the larger the jacking pit is. Consider future access needs for maintenance of the carrier pipe in the casing and try to maintain future access by keeping other utilities away from future access pits.

B. Other Utility Crossings

The design engineer should determine where casings are needed at locations where an SPU transmission main is crossing either over or under other utilities. For separation requirements between water mains and other utilities, see [Standard Specifications section 1-07.17\(2\)A1](#) and Standard Plans 286A and 286B. All ductile iron pipe in casings must have RJs. See Standard Specifications sections 7-11 3(6)D and 7-11.3(7)C-D2.

C. Rail Crossings

Where water mains cross under a rail system (e.g., streetcar, light or heavy rail, or other as determined by SPU), the main must be placed inside a casing. The casing must extend such a distance from the tracks that maintenance can be performed from the side without affecting the rail or requiring a permit from the rail owner to perform construction activities. For cathodic protection for pipes crossing a rail line, see [DSG Chapter 6, Cathodic Protection](#), Test Procedure 31 – Light Rail and Streetcar Cooperative Interference Testing.

I) Heavy Rail

When crossing beneath heavy rail, a casing must extend from ROW line to ROW line unless the main is more than 25 ft from the track centerline. If the railroad agrees, the casing must extend a minimum of 25 ft from the track centerline. See the [American Railway Engineering and Maintenance-of-Way Association \(AREMA\) Design Guideline](#) before designing a heavy rail crossing.

2) Light Rail

Light rail does not impose the extreme loading on pipelines that heavy rail does. However, light rail imparts some loading and causes significant pipeline access issues and stray current corrosion concerns.

Water mains crossing beneath Sound Transit Central Link light rail tracks are encased a minimum distance of 12 ft perpendicular to the centerline of the track. The tracks have a 5.5 ft minimum separation between the top of the rail and the top of the casing. See the [Sound Transit Design Criteria Manual](#).

Casings crossing a light rail line must be electrically isolated from the carrier pipe. A permanent test station should be installed to perform future isolation checks. See [DSG Chapter 6, Cathodic Protection](#), Test Procedure 31 – Light Rail and Streetcar Cooperative Interference Testing.

3) Streetcar

The presently used streetcar designs have the least impact on buried pipelines of the three types of rail. Streetcars are smaller and lighter, but they still limit pipeline access and they generate stray current.

The design engineer must consider depth of cover, pipeline size, age, thickness, material, importance, and access.

The design engineer should consider various pipeline protection methods ranging from do nothing to casings and protective concrete slabs.

D. Parallel Rail Installations

For worker safety, parallel mains should not be closer than 15 ft from the rail centerline. However, rail installation will likely have to be considered case by case.

5.6.3.5 Pipe Supports

Pipe supports must be designed under the direction of a licensed civil or structural engineer who is responsible for reviewing pipe loads and potential deflections caused by lateral and vertical movement. AWWA M11 (Steel Pipe Design) and AWWA M41 (Ductile Iron Pipe Design) manuals provide some explanation on how to properly design pipes on supports. The Ductile Iron Pipe Research Association (DIPRA) also publishes a computer program for selecting and spacing supports for ductile iron pipe.

A. Pile Supports

Pile-supported pipelines are rare in the SPU water system. However, in some locations, such as crossing a wetland or in loose soils, pile-supported pipelines may be necessary. A licensed civil or structural engineer must design the pile support and calculate pipeline thickness. Because pipelines installed on piles are typically not continuously supported, they present unique design challenges. Among the issues are additional stresses placed on the pipeline due to the lack of support. Such design issues must be investigated and modeled by a licensed structural engineer.

1) Above Grade Pile Support

For an above-grade sun and weather exposed pile support, the design engineer should consider the coating system used for both the pipeline and piles. In most cases, both the pile and pipe will require a coating, and cathodic protection should be considered. Additionally, pipeline insulation may be needed to protect the line from freezing temperatures during no-flow or low-flow situations. The insulation must be protected from vandalism and rodents and must not be allowed to absorb water. Above-ground pipelines should be analyzed for thermal expansion/contraction movement requiring a flexible joint provision. Address pipe restraint at the flexible joint.

2) Buried Support

If the pipeline is on piles and buried, a qualified licensed civil or structural engineer should carefully review the connection to the piles to ensure the pipe and piles operate as one entity during seismic and uplift conditions.

B. Aerial/Bridge Supports

SPU owns and operates a few aerial (above-ground) pipelines in its water system. A structural engineer licensed in Washington State should be involved in aerial pipeline design. Aerial pipelines present unique design challenges because, like pipelines on piles, they are not continuously supported.

Aerial pipelines can either be supported from above, by hanging the pipe, or cradled in a utility corridor under the bridge. In either case, the pipe supports place additional loadings on the pipe wall.

The following are special considerations for aerial design:

- Where possible, aerial pipelines should be avoided for security and vibration concerns.
- When pipes are hung under existing bridges, roadway clearance design must consider the potential for damage from trucks traveling above the legal height limit. Additional protection should be considered such as line valves or structural modifications to the bridge.
- With an exposed pipe design, the design engineer must consider the pipeline coating system. Additionally, pipeline insulation may be needed to help control thermal expansion of the pipeline and to prevent the line from freezing temperatures and no-flow situations. The insulation must be protected from vandalism and rodents and must not be allowed to absorb water. AWWA Manual M11 provides an analysis method to determine if freezing is a concern.
- The design engineer must carefully review the buried-to-aerial transition to ensure the pipeline will be able to handle thrust loads if present, ground movement from earthquakes and thermal expansion/contraction movements. In most cases, a restrained joint (RJ) with both rotational and expansion capabilities (e.g., a double ball expansion joint fitting) is recommended. See also DSG section 5.10.
- Freeze protection design must be considered. Potential options include one or more of the following:
 - Insulation of the pipe

- Heat tape
- In case of a temporary change in the way the pipe is used resulting in low flows, consider installation of a system to allow a release of a small volume of water to a location that does not cause an environmental impact or safety hazards

5.6.4 Chambers (Vaults)

5.6.4.1 Vaults

Terminology: [Standard Specifications section 9-30.3\(12\)](#) refers to valve chambers for material specification for bidding purposes. The Standard Specifications also refer to “electrical vaults” in sections 1-05.2(2) and 1-07.28 paragraph 8)a and elsewhere and Seattle City Light (SCL) projects will refer to electrical vaults. Functionally, chambers and vaults are the same. Namely, they provide access space for operation or maintenance of the enclosed equipment. If “vault” is the terminology used on plans, it should be tied to the bid item terminology called “chambers” to be unambiguous.

Chambers are required for:

- All water system valves 16 inches and larger as standard practice
- DVs that separate service pressure zones
- All buried installations that have electrical service and electronic sensors
- Transmission main blowoff valves and access ports where excavation is inadvisable, such as in traffic areas
- Large orifice air and vacuum valves (AVVs), PR valves, PRVs, and check valves
- Water services larger than 2 inches
- All water services to purveyor meters

Without exception, all chambers that have electricity or electrical equipment must be drained. Either gravity drains or electrically powered sump pumps with liquid level alarms sent via SCADA to the Operations Control Center (OCC) may be used depending on availability of significant slope at the chamber location. Provide a sump with a galvanized metal or fiberglass grate to cover the sump that is flush with the chamber floor.

Provide 18 inches of clear space around piping and equipment for access and maintenance. Where space is tight, provide no less than 18 inches on one side and no less than 12 inches on the opposite side. There must be enough room to access all fastening hardware, and to remove, replace, and perform maintenance on valve actuators, bearings, and seals. For PR valves and PRVs consult the manufacturer’s literature for clearances on each side of the valve and overhead needed to remove the valve bonnet and pilots for maintenance.

Where possible, locate chambers out of roadway surfaces. Provide an equipment access over large and heavy equipment and personnel access to all locations inside the chamber. Additional access guidance is described below:

- Personnel access openings formed into the top of a concrete chamber must be a minimum of 30 inches in diameter, with a Standard Plan Type 361 Valve Chamber Frame and Cover if the chamber is in the street. If the chamber is located outside of driving

surfaces, the personnel access opening must be a 3-ft square opening cast into the chamber top with hatches.

- Equipment access for removal and maintenance is required. If the chamber is in a street, the equipment access may be a circular opening cast into the chamber top that is 30 inches or larger. Larger equipment will require a larger opening. The Standard Plan Type 361 Valve Chamber Frame and Cover should be used for 30-inch openings in streets but larger circular openings which may be needed will require a larger, non-standard frame and cover. These larger frames and covers include lids that can weigh over 200 lbs, making them difficult for Operations personnel to use. SPU has used the larger non-standard frame and covers with a second lid inset within the main cover. If access to a valve operating nut is required, the smaller inset cover should be placed over the operating nut. A key issue in non-standard frame and covers is the paving surrounding them. Asphalt concrete pavement is more tolerant to shallow frames, while Portland cement concrete paving requires a tall frame. Seattle Department of Transportation (SDOT) should be consulted regarding non-standard frame types allowed in streets. As mentioned above, the preference is to locate chambers out of driving surfaces. Then, larger rectangular hatch-covered openings, which may be needed for larger equipment, can be formed into the chamber top and equipped with a hatch size that matches the chamber top opening.
- Provide two or more courses of brick and mortar for adjustment of casting (frame and cover) and hatch elevations (see [Standard Specifications section 7-12.3\[3\]](#)).
- Provide floor-supported galvanized steel or stainless-steel ladders with a ladder safety device extendable to 3 ft or more above ground surface for all personnel access openings. Provide 15-inch minimum lateral clearance on each side of the ladder centerline and 30-inch minimum clearance in front of the ladder.
- Where chambers are in the street and internal equipment is larger than the largest viable, allowed frame and cover, consider how the internal equipment will be replaced and the effects of paving replacement and traffic control if pavement has to be removed. Where large equipment will be removed from chambers, the chamber top may need to be removable. The chamber structure must be designed to allow the removal of the chamber top with existing soil and water loadings remaining in place.
- Another method to provide access for removal of large equipment located in the street by covering large rectangular openings, which are cast into the buried chamber top, with a solid reinforced concrete slab. Some chamber openings are large enough that two slabs can be installed side by side as a covering. This can be easier to remove than one larger slab due to weight considerations. An 8- to 9-inch opening can be cast into a slab(s) for an adjustable valve box to be inserted over valve operating nuts. Before placing a slab covering, apply mastic sealant to the chamber top around the opening.
- Vault tops and cover slabs that are designed to be removed to allow large equipment into and out of the vault chamber must be fitted with 3/4-inch MeadowBurke FX-5 Ferrule Insert – Loops and plastic plugs to prevent soil from entering the threads. These ferrule inserts match SPU existing lifting hardware. Provide enough ferrule inserts in locations to lift the weight of the vault top or cover slab safely.

Figure 5-5 depicts the typical layout of a 16-inch or larger line valve in a traffic location.

Figure 5-5
Typical Layout of a 16-inch or Larger Line Valve in Driving Surface

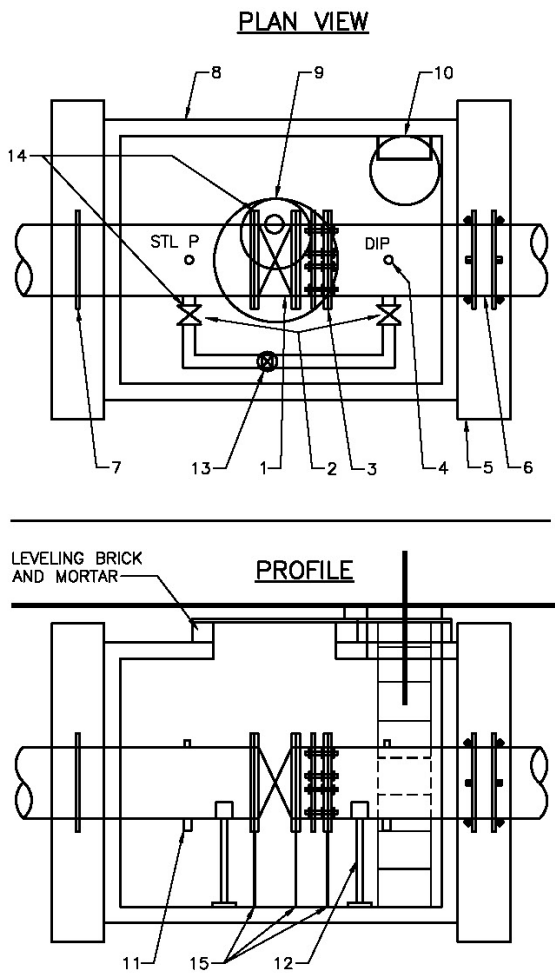

NOTES:

1. 16"-30" LINE VALVE (SHOWN AS FLXFL)
2. BYPASS VALVE (TYPICALLY 4"), FLXMJ, WITH OP NUT EXTENSION AND VALVE BOX
3. FLXFL DISMANTLING JOINT
4. AWWA X IPT CORPS ON EACH SIDE OF VALVE ON TOP AND BOTTOM IF LEVEL FOR AIR FLOW AND DRAINING, OR ONE ON TOP ON LOW SIDE OF VALVE AND THE OTHER ON BOTTOM ON HIGH SIDE OF VALVE IF PIPE IS SLOPING
5. REINFORCED CONCRETE THRUST COLLAR (GENERALLY NOT NECESSARY ON WELDED STEEL PIPE)
6. BACK TO BACK OPPOSING WEDGE RESTRAINT GLANDS POLY BAGGED (OPTION A)(NOT APPLICABLE TO WELDED STEEL PIPE)
7. WELDED STEEL COLLAR (OPTION B) (GENERALLY NOT NECESSARY ON WELDED STEEL PIPE) UNLESS CONCRETE BLOCKING IS NEEDED
8. PRECAST OR CAST IN PLACE CHAMBER. IF CAST IN PLACE, THRUST COLLARS CAN BE INTEGRAL TO CHAMBER.
9. 42" FRAME AND COVER WITH 24 INNER COVER. CENTER 42" COVER OVER VALVE AND 24" COVER OVER VALVE OPERATOR.
10. STANDARD PLAN TYPE 361 FRAME AND COVER AND LADDER FOR ACCESS. W/30"ID OPENING IN CHAMBER TOP.
11. AWWA X IPT CORP ONE EACH SIDE OF VALVE, BOTTOM OF PIPE
12. PIPE SUPPORT STAND TYPICAL OF 2 (AS NEEDED)
13. TEE WITH OUTLET TURNED DOWN AND PLUG IN OUTLET ALL BYPASS PIPING TO BE MJ W/MEGA-LUGS
14. FLANGE INSULATING KIT (ON STL P TO DIP) IF STL P IS ON BOTH SIDES OF VALVE, OMIT FLANGE INSULATING KIT AND INSTALL A JUMPER ACROSS VALVE AND DISMANTLING JOINT FROM STL P TO STL P.
15. SHOW ADJUSTABLE FLANGE SUPPORTS UNDER BOTH VALVE FLANGES AND UNDER THE RIGHT DISMANTLING JOINT FLANGE.

GENERAL NOTES:

- A. DESIGNS WILL VARY DEPENDING ON PIPE TYPE (DUCTILE VS STEEL) AND JOINT TYPE.
- B. SIZES OF ALL VALVES SHOWN CAN VARY DEPENDING ON LINE VALVE SIZE AND USE.
- C. CHAMBER SIZE AND PIPE ALIGNMENT WITHIN THE CHAMBER WILL VARY DEPENDING ON SITE CONDITIONS.
- D. FOR CLARITY NOT ALL PIPE JOINTS ARE SHOWN. A PIPE JOINT SHOULD BE INSTALLED OUTSIDE THE CHAMBER WITHIN A FEW FEET OF THE THRUST COLLARS WHEN USING FLEXIBLE JOINT PIPE AND WHERE TRANSITIONS FROM NEW PIPE TO EXISTING PIPE OCCURS.
- E. DISMANTLING JOINTS DO NOT RESTRAIN PIPE IN COMPRESSION IF CHAMBER IS PART OF LINE VALVE THRUST RESTRAINT. IT MUST BE CAPABLE OF TRANSFERRING THE THRUST. TYPICALLY CHAMBER WALLS ARE DESIGNED WITH LIGHT DUTY WIRE FABRIC REINFORCEMENT AND ARE NOT DESIGNED TO TAKE THRUST LOADS.
- F. PLACE PIPE SUPPORTS UNDER BOTH BYPASS AND UNDER TEE.
- G. CHAMBER SUMP AND GRATE NOT SHOWN.
- H. SKETCH IS NOT-TO-SCALE. CHAMBER TOP AND THRUST COLLAR ELEVATIONS MUST BE BELOW PAVING AND BE ACCEPTABLE TO SDOT.
- I. CHAMBERS FOR LARGE MAINS SHOULD HAVE ACCESS ON BOTH SIDES OF PIPE.

5.6.4.2 Clearances

A. Clearance for Maintenance

Clearance for maintenance around valves and appurtenances inside chambers is very important to maintenance staff. When sizing a chamber, the design engineer should ensure that maintenance staff can access all parts of the enclosed equipment with enough space for wrenches and other tools. Typically, a **minimum** of 1-ft space is needed around all sides of the equipment. SPU prefers a 2-ft space for personnel movement, if possible, but 18 inches of clearance may be the best trade-off between chamber size and maintenance access. WISHA ladder requirements provide for 15 inches of clearance on both sides of a ladder and 30 inches behind the ladder, but this is not always possible for chambers in congested locations.

Flanges that are 12 inches or smaller have bolts and nuts sized between 1/2 inch and 7/8 inch, requiring tools that are approximately 12 inches in length. Tools for flanges that are 16 inches or larger with hardware 1 to 1-3/4 inches in size can often be longer than 18 inches. Increase chamber wall clearance from 18 inches to 24 inches for piping that is 16 inches or larger. This allows increased clearance for movement of tools and space for crews to apply leverage to the tools. The design should accommodate more space, if possible, for 1-3/4-inch bolting hardware.

Allow 9 inches or more of space between ball corps for bypass piping, air release, and draining and adjacent chamber walls and pipe joints.

B. Clearance for Valve Replacements

Hatch and frames and covers must be adequately sized to remove the valve. This means that the frame and cover for valve removal may not be an SPU Standard Plan Type 361 Valve Chamber Frame and Cover. Large heavy frames and covers are generally to be avoided, if possible, though they may be unavoidable for in-traffic locations. Last-resort methods of access include use of a buried precast cover slabs over the chamber top opening or removal of the valve chamber top altogether, both of which have significant traffic, paving, and cost impacts.

Another consideration for valve removal is a dismantling joint. When flanged valves are installed, the fit of mating flanges is extremely tight. If the valve needs to be replaced, unbolting it will not provide sufficient space to slide the valve out. A dismantling joint has a sleeve that can be retracted an inch or two. This allows enough extra space to remove the valve. The dismantling joint also provides some adjustment if a different brand or style of valve is installed in the future. SPU standard practice is to install a dismantling joint on valves 16-inch and larger in diameter. Dismantling joints can transfer thrust in tension but not in compression.

5.6.4.3 Hatches

As ergonomic and worker safety practices evolve, SPU has been migrating away from use of heavy castings such as Standard Plan Type 361 Frames and Covers wherever possible for both personnel and equipment access to chambers. **Chamber access in traffic locations must still be through cast frames and covers.** By locating chambers in non-traffic areas such as planting strips and sidewalks, where allowed, hatches can be used for chamber access. The following hatch

features have been chosen to balance the often-competing needs of maintenance personnel, lifespan, security, and loading conditions:

- Access hatch frames and covers should support HS-25 loads with a maximum deflection of 1/150 of the hatch span. The surface of an access hatch must be a non-skid surface.
- Diamond tread surface pattern is not to be used in pedestrian walkways, where hatches are allowed by SDOT. In sidewalks, a durable metallic non-skid finish will be needed, such as SlipNOT or similar product.
- Provide lift-assist mechanisms having stainless-steel compression springs in stainless steel-telescoping tubes. Selected lift-assist mechanisms should require no routine maintenance and provide smooth and controlled opening and closing. All moving parts must be configured to prevent operator injury. Required lifting force must not exceed 40 lbs. All lift-assist mechanisms must be factory set.
- Operation of the hatch cover must not be affected by temperature.
- Hinges must be of a concealed tamper-proof construction.
- Access hatches must include a covered, recessed, vandal-resistant padlock hasp box with adequate room for use of a heavy-duty pad lock. The padlock hasp box must be located below the surface of the hatch. The cover for the padlock hasp box must close naturally when not purposefully opened.
- Hatches must include a stainless steel or galvanized steel slam locking mechanism that holds the hatch firmly on the frame when closed. The slam lock must be equipped with a non-removable handle built into the hatch top or located below the hatch top, and it must be accessible through the cover of the padlock hasp box.
- All fasteners must be made from stainless steel.
- Access hatches must include fall protection posts and chains meeting Washington Industrial Safety and Health Administration (WISHA) regulations where personnel are required to work near open accesses. Protection posts must be able to be stored underneath the hatch.
- Access hatches must include a 1.5-inch or larger drain coupling if the hatch is equipped with a frame drain. Drain piping must be routed, as indicated in the drawings.
- All aluminum must be coated with epoxy paint or mastic tape where contact with cementitious material or metals other than stainless steel is possible. Cementitious materials corrode aluminum rapidly when directly in contact.
- Hatches and appurtenances must be under warrantee and free of defects in material and workmanship for a period of five years from the date of acceptance by SPU. The manufacturer must repair or replace the hatch at no charge if a part should fail from normal use within this period. A warranty in the form of a submittal must be specified in the contract.
- All hatches and appurtenances must be installed per manufacturer's requirements and must be flush with adjacent concrete surfaces. Hatches and appurtenances must be adjusted and tested that they meet specified functions and proper operation.

5.6.5 Appurtenances

Pipeline appurtenances (line valves, access ports, blowoff/drains, and air release valve (ARV)/AVVs) should be provided along the pipeline as needed to support the pipeline function and operation. Appurtenance locations should be determined during design and consider conflicts with other structures, vehicular traffic, and existing utilities. Appurtenance locations should avoid areas most vulnerable to damage or vandalism.

5.6.5.1 Valves

SPU owns about 21,500 valves of various types that support the SPU water system. SPU installs most valves where needed for ease of operation and system redundancy.

When a distribution main, feeder main, or pipeline requires a valve, note the function (use) of the valve when selecting the type (physical design and characteristics) of the valve. The valve's function, type, and nominal diameter will have a bearing on additional requirements for the overall valve assembly. Note provisions specifying instances in which a valve bypass assembly or maintenance vault is required. Pay close attention to maintenance clearances, dismantling features, and other details included in the requirements for more complex valve installations.

The number of turns to close a valve is very important. Rapidly closing a valve can create a surge pressure wave (water hammer) in the pipeline and damage the line and appurtenances. See Standard Specifications section 9-30.3(3).

A. Principal Valve Functions within the Water System

Broadly speaking, there are four types of valve functions: Non-modulating (non-throttling) valves, modulating (throttling) valves, check (non-return) valves, and air valves. Examples of how these functions are incorporated into the water system are presented below together with the related hardware selection criteria.

1) Non-Modulating (Non-Throttling) Valves

Non-modulating (non-throttling) valves remain in either a normally open or a normally closed position. They are changed to the opposite position when needed to perform their function. Non-modulating valves are typically thought of as manually actuated by either turning the operating nut on the valve using a gate key or by manually operating the valve using a powered valve actuator through a switch or SCADA control. Non-modulating valves are rarely set in a partially open (or closed) position, except for situations where the downstream pipe may be subject to imminent failure.

For example, a partially open non-modulating valve may be appropriate in order to provide reduced service to customers in a portion of the water system located in an actively unstable soil situation (like landslides). In this situation, a non-modulating valve that is normally open will be closed enough to allow only a small domestic supply to feed the area. Fire supply is greatly limited and is only possible by re-opening the valve. This partially open position limits the amount of water that can escape in the case where the unstable soil moves and causes the water main to separate. The partially open condition is only temporary until the soil (or other issue of concern) is stabilized.

Line valves are used to isolate segments of the water distribution grid, the feeder network or transmission pipelines. The normal position for a line valve is fully open, with the valve being moved to a fully closed position to stop flow through (or “section off”) a

portion of pipe. If all line valves to a run of pipe are closed, the main can be drained for new construction or repair activities while limiting the water outage to a subset of the local customers. The subsequent DSG section titled *Valve Placement Strategy within the Water Distribution System* outlines guidance for how line valve locations are selected to allow both flexibility of operation and a minimum of disruption to our customers during water main shutdowns.

Line valves are typically either gate or BFVs, depending on pipeline size. Ball and plug valves may be used in the following situations:

- High pressure (± 250 psi)
- Significant throttling under high flow rates (such as blowoff valves)
- Control of pressure surges (not typically a line valve function)
- Where throttling of high-pressure differentials may be required (such as blowoff valves)

GVs meeting AWWA C500 or C509 requirements are the standard practice for 12 inch and smaller pipe in locations meeting standard cover requirements in Standard Plan 030. GV completely exit the flow path when fully open and allow drained water mains to fill without bypasses. However, GV require space for the valve bonnet above or to the side (laydown valves) of the pipeline. Depth of cover over a water main may be critical. Avoid placing valves in shallow cover locations. **In cases where substandard cover over the valve is unavoidable, the GV operating nut must be located below the bottom of the paving and the valve box must rest on a 2-inch thick plastic foam ring (Standard Plan 313b) above the valve body. Under no circumstances should the valve box casting have contact with the valve, which can damage the valve when heavy traffic loads flex the pavement.** Shallow cover is a particularly sensitive concern for concrete pavement, which tends to be thick.

AWWA C504 BFVs are frequently used on larger pipelines. All valves 16 inches and larger should be full-size inline BFVs and be installed in chambers. Standard practice for valves under 16-inches is to use GV, but BFVs can be used where GV will not fit. **BFVs 16 inches or larger must be installed with a bypass to allow a drained pipe to fill without throttling the BFV seats.** Bypass valves are described below in this section.

Throttling of large-diameter BFVs is a primary reason seats have been destroyed after only one or two uses. Make provision for replacement of BFVs in the chamber design. Include a dismantling joint, or similar, to enable disassembly of the pipe and design chamber to accommodate replacement.

GVs 16 inches and larger are typically more expensive than BFVs. They are typically flanged on both ends, which enables vertical lifting during replacement and avoids extensive pipe work. **GVs 16 inches and larger must be operable from the street surface. Laydown GV are used where the pipe has standard cover and they require a sealed right-angle gearbox.** At some locations where the pipe is deeper than standard depth, the GV can be installed as an upright GV and the actuator can be a sealed spur gear arrangement. Enclose 16 inch and larger GV in a chamber that is accessible for inspection, maintenance, and removal. Dismantling joints are used for enabling removal of the valve from the line. Always consider the need for bypass valves. Unlike large BFVs, bypass valves for GV can be bolted directly to the GV body. Bypass valves mounted on

the GV are compact and save room. Bypass valves must be operable from the street surface.

Isolation valves are non-modulating valves that are used to section off or partition a distribution grid or pipe within a common pressure zone. Applications may include maintaining seasonal water supply regimes and limiting the risk posed by threatened water mains. The separation provided by Isolation valves is significant in the way it alters water circulation through a pressure zone. Unlike a DV (see next section), an isolation valve can be opened without causing harm to the water system or customers and opening it removes the partitioning operation for which it is designed.

The term isolation valve is also used for valves installed on both sides of appurtenances such as pumps, modulating valves, and meters, which are to be periodically removed from service for inspection or maintenance.

District valves (DVs) are non-modulating valves that are used to isolate physically connected pipe into service areas with different water pressures (pressure zones) on both sides of the valves. DVs have an advantage over physical pipe separation as a means of separating adjacent pressure zones because they reserve the option of temporarily removing a pressure zone boundary. In addition, DVs allow one zone to supply its neighboring zone under certain emergency conditions. DVs normally remain in the closed position for decades.

Because DVs effectively create two dead ends, DVs should be located adjacent to a fire hydrant whenever possible. Typically, a DV will be positioned on the water main to one side of an adjacent hydrant tee and a second line valve will be located on the opposite side of the hydrant tee from the DV (Figure 5-6). This arrangement allows the two water main segments approaching the closed DV to be flushed in separate operations. The fire hydrant provides a discharge capacity that ensures effective flushing velocities. The hydrant also facilitates pressure management and overpressure protection during emergency throttling operations at the DV. **SPU Operations personnel will determine which of the two valves at the hydrant tee will serve as the DV.**

Regardless of the DV designation, the valve placed on the higher-pressure side of the hydrant tee should be a metal seated, double-disc gate valve (DDGV) meeting AWWA C500. The GV on the lower pressure side of the hydrant may be either a DDGV or a resilient wedge gate valve (RWGV) meeting AWWA C509, which contractors can readily provide. Whether the DDGV is designated as the normally closed DV, it will serve as the throttling valve during emergency supply operations requiring the higher-pressure zone to feed the lower pressure zone.

Advance planning may be required to obtain DDGVs because few manufacturers still produce these valves in the 4-inch through 12-inch sizes and the production run is typically limited. Very long lead times should be expected if a contractor is required to furnish them. Alternatively, SPU can specify that it will provide this valve.

Figure 5-6
Pressure Zone Boundary District Valve Co-Located with a Standard Plan Type 311 Fire Hydrant

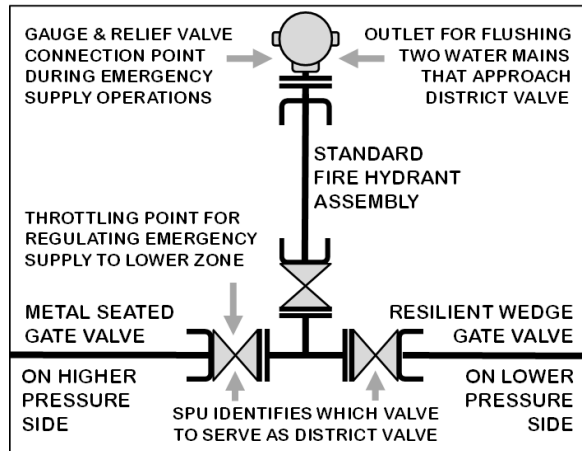

Notes

¹ The hydrant may also be a Standard Plan Type 310 hydrant or a Type 311 hydrant with a second valve at the hydrant for wide or busy streets.

When placement of a DV adjacent to a fire hydrant is not possible, a 2-inch outlet on both sides of the DV is required to allow flushing of the water main segments approaching the DV. Typically, corporation stops are used, and are positioned at the crown of the pipe to assist in air and vacuum relief during a shutdown.

A chamber must be provided for the DV and both flushing outlets to allow hose connections if the outlets are not otherwise permanently piped to an access hand hole, such as blowoffs per Standard Plan 340a or 340b. Corporation stops must be plugged or capped when not in use to avoid cross-connection contamination.

Service supply valves and branch supply valves are similar, as they permit the supply of water from a distribution water main to be shut off to a metered water service or to another unmetered lateral (branch), such as a fire hydrant lateral, or water main stub that is installed for future water main extension. Service supply valves and branch supply valves are typically installed and tested as part of a new water main’s construction. [Standard Plan Type 311](#) hydrant branches, 3-inch and larger water services, and headers supplying multiple remote water services, begin from the service supply valves and branch supply valves attached to the water main. Standard Plan Type 310 hydrants do not have a branch supply valve.

When hydrants are installed on streets with high-volume traffic, SPU will often require a Standard Plan Type 311 hydrant with an extra valve at the hydrant, similar to the Type 310 hydrant. The valve at the main is left open but may be closed to isolate the hydrant branch for hydrant reconstruction purposes, when needed. The valve at the hydrant allows crews to perform normal O&M activities without disrupting the flow of traffic.

Blowoff valves are typically 4-inch and larger valves that SPU maintains at the low points of transmission mains and feeders that permit draining large-diameter pipes down to their inverts. Valves 2 inches and smaller are used at dead end distribution mains that are 8 inches or smaller for flushing the mains and removing air at local high

points if hydrants are not installed. The valves for these two relatively different functions are referred to as blowoff valves.

Large pipe draining: Blowoff valves are located at the low points along a larger-diameter (> 12") feeder or transmission mains. They primarily exist to drain the pipe during a shutdown. A blowoff valve installation on large pipes, and smaller pipes with a high initial pressure, requires an assembly that includes two valves in series. The valve connected directly to the feeder or pipeline is reserved for leak-tight sealing of the blowoff outlet. It is the blowoff isolation valve. The second valve is used to control the water discharge flow rate.

Because blowoff valves usually discharge to the atmosphere, operating a blowoff valve can involve moderate to extremely high-pressure differentials. Regular maintenance includes exercising the valve, which involves slightly opening the blowoff valve to flush the piping and closing them again while the main is in service. For high pressure applications, 200 psi or above, the preferred blowoff isolation valve type is a lubricated plug valve or ball valve. For pressures at less than 200 psi, a DDGV is preferred. In cases where retrofitting existing isolation valves is required and a plug valve cannot be reinstalled, a high pressure BFV (HP BFV) (AWWA Class 250) can be used in place of the isolation valve. Some BFV manufacturers can make BFVs rated as high as 350 psi.

The second blowoff valve is a throttling valve (also referred to as a sacrificial valve). The throttling valve is manually operated in a partially open position as a variable orifice to throttle the discharge flow rate to an acceptable level. Throttling characteristics of valves is important to understand. When water passes through a valve from a pressurized system to near atmospheric pressure, as happens in most blowoff valves, three components of the Bernoulli equation undergo rapid changes across the valve seat. Only the elevation component remains essentially unchanged. The changing components are described below, with the partially opened valve seat acting as a variable-sized non-circular orifice:

- Velocity upstream of the sacrificial valve is relatively low but accelerates to a very high value as it passes the valve's opened seat. Downstream of the valve seat the velocity returns to a relatively low value. In the very short orifice location, the water velocity may be so high that it erodes the metal (and elastomer coating in RWGVs) in the seating area. Thus, throttling valves should not use rubber seats, which would very quickly deteriorate.
- Pressure upstream of the valve seat is relatively high when a pipe begins draining and decreases as the pipe is dewatered. Downstream of the valve seat, the pressure goes to atmospheric plus the back-pressure friction losses and static head of water in the riser are pipe to the air gap location. At the partially opened valve's orifice, the pressure can drop below the vapor pressure of water, which is approximately 0.09 psi absolute (psia) (-14.61 psi gauge [psig]) at 32°F to approximately 0.34 psia (-14.36 psig) at 68°F. When this occurs, the water briefly turns to water vapor bubbles (a process called flashing). These bubbles collapse violently as the pressure returns to above vapor pressure immediately downstream of the valve seat. This sequence of events is called cavitation and is destructive to valves. Laboratory tests have shown that the collapsing bubble pressures are 100,000 psi or more in water. When this happens near the valve's seat or body, the metal is removed over time. If the

bubbles collapse where they are surrounded by liquid only, the process is merely loud but no damage occurs.

- The last variable in the Bernoulli equation is the head loss. When the valve is mostly closed, the head loss is high. When the valve is fully open, the head loss is very minimal. When a valve is throttled and when cavitation occurs there is an irrecoverable loss of energy, which is preferable in blowoff valves because the ultimate objective of the valve is to discharge to atmospheric pressure through an air gap.

When choosing sacrificial throttling valves, there is a trade-off between valve cost and sacrificial valve service life. When low cost DDGVs and RWGVs are used, the energy of reducing pressure occurs across one crescent-shaped orifice. BFVs are also single orifice valves, but the orifice shape is two crescents facing each other. With minimal BFV disc rotation, there is a very large variance in orifice size, making BFVs useless for throttling as blowoff valves.

Note: BFVs are never to be used as the sacrificial valve.

Alternatively, higher cost plug valves and ball valves use two orifices to reduce the pressure. The first orifice is crescent shaped and located where the water enters the valve body. Approximately one-half of the total reduction in pressure occurs at this orifice. The water then expands to fill the plug or ball's cross-sectional area, which reduces the velocity in the valve after the first orifice and increases the back pressure on the first orifice. This increased pressure reduces the potential for cavitation and its severity at the first orifice. The water then flows through the valve to the second crescent-shaped orifice at the downstream seat of the plug and ball valves. The water speeds up through the second orifice and the pressure lowers. The remaining one-half of the total pressure loss occurs at this stage, and the cavitation potential and severity at the downstream seat is also reduced. Since the pressure is removed in two stages, across two orifices, the valve must be opened more than a single ported valve to achieve the same flow rate as a single-ported valve. This reduces the velocity across the orifices, which in turn lowers the magnitude of valve seat erosion. Thus, these valves last longer as a sacrificial valve.

DDGVs (AWWA C500) are single-ported valves and are preferred for sacrificial valves since they are the cheapest durable throttling valve. If the maximum pipeline pressure differential to atmosphere is over 200 psi, high pressure RWGVs, lubricated plug valves, or metal seated AWWA ball valves, in that preferred order, may be required. RWGVs are single-ported valves that are expected to lose the bonded elastomer encapsulating the valve's gate relatively quickly compared with other valves, but the remaining metal gate should remain serviceable for many blowoff operations. Plug valves are durable, double-ported valves that should have a long lifespan compared with single-ported valves, but they are relatively expensive. Metal-seated ball valves are expensive, double-ported valves that are capable of throttling, but they are also expensive to refurbish and/or replace.

Sacrificial throttling valves are best located where the rate of flow can be observed at the air gap. Standard water castings, such as valve boxes per Standard Plan 315 or

frame and covers per Standard Plan 361, are used to access the operating nuts of blowoff isolation valves and sacrificial throttling valves.

Replacement of the sacrificial valve, due to wear or damage during blowoff operations, is enabled while the pipeline is in operation because the isolation valve is closed. Always provide a fitting such as a dismantling joint, or a piping arrangement such as a 90° bend adjacent to the sacrificial valve that allows the piping to be dismantled to replace the sacrificial valve. Blowoff valve systems on transmission lines are usually deep and are installed within a blowoff chamber for maintenance access with operating nuts accessible from the ground surface.

Blowoff air gaps: Following the sacrificial valve, a riser brings the discharged water to an air gap at the surface. Blowoff draining flow rates are limited by the receiving utility or water body. A tap to add sodium thiosulfate or ascorbic acid for dechlorinating water can be provided at the blowoff, but this is not common. De-chlorinating chemicals are often added at the air gap structure under atmospheric pressure conditions.

All blowoff outlets must have an air gap (see DSG section 5.6.5.3) to physically separate potable water from non-potable water to meet DOH requirements for cross-connection control and backflow prevention. For examples of blowoff air gaps and sacrificial throttling valves, see the City's [Seattle Digital Infrastructure Records](#) (SeaDIR) plan 776-448 sheet 38, 776-227 sheets 11 and 12, and 776-203 sheets 4 and 5. Additionally, Plan 776-203 shows a special condition where water is transferred to another pipeline through a pipeline-to-pipeline pumping connection to reduce lost water and avoid discharging water to the environment. Plan 776-448 shows a removable air gap gooseneck for locations where high public presence is anticipated, such as the Burke-Gilman Trail.

Small pipe flushing: Blowoff valves located at the dead ends of distribution mains are provided in the form of smaller diameter laterals, typically consisting of 2-inch copper tubing. For details on design of small blowoff valves, see Standard Specifications section 7-11.3(14) and Standard Plans 340a and 340b.

When distribution system dead ends cannot be avoided, 8-inch and 12-inch standard main diameters should terminate with a fire hydrant. To the extent that additional water main is needed between the last hydrant on the dead end main and the end of the actual end of the main, a reduced diameter is preferred. Distribution blowoff valves are intended to support water main flushing involving these relatively short segments of smaller diameter water main. When incremental water main construction requires creation of a **temporary** dead end larger than 8 inches in diameter, a 4-inch blowoff or **temporary** hydrant should be provided.

Bypass valves are non-modulating valves installed in assemblies around larger valves to ease valve opening, and around 3-inch and larger Domestic and Combination service meters to provide unmetered service during meter maintenance.

When a water main has been drained on one side of a large GV, the pressure on the valve disc becomes unbalanced making it very difficult to open the valve. A bypass assembly around the large GV allows water to fill the drained side of the GV. When the drained side is filled and the pressure equalizes on both sides of the GV, the valve opens more easily. Bypass assemblies also allow the operator to fill an empty pipe with much

better control. Since large gate valves typically have bonnets that are quite tall, they do not fit under street paving and are therefore installed laying on their sides. These “laydown” valves typically have bypasses installed directly on the valve body.

Beginning in the 1990s, 16-inch and larger diameter line valves and isolation valves are typically BFVs due to their lower cost and smaller size. SPU learned that **BFVs must not be used to fill drained pipes**. The rubber seat on brand new BFVs can be destroyed after only one or two fillings of dewatered pipe.

SPU practice is to install bypass assemblies on all valves 16-inches and larger diameter.

A typical bypass assembly is included in the standard line valve chamber detail, see Figure 5-5. The bypass assembly size is usually 4-inch for most locations but 6-inch or 8-inch may be needed for large-diameter transmission main bypasses to reduce filling time to an acceptable level. On each bypass assembly, SPU practice is to install two bypass valves, attached directly to the main line by flanged connections, one on each side of the main line valve. Between these two valves, the plumbing includes a tee with a down-turned outlet with a plug in the outlet. The bypass assembly is supported from the floor at the bends and at the tee. With this arrangement, the bypass assembly functions can also be used to drain the piping on each side of the main valve.

Where the pipe volume to fill is relatively small and the time needed to fill is only an hour or two, the bypass can be constructed by installing 1-½” x 2”, AWWA x MPT, brass-bodied ball corps on the top of the pipe, on each side of the BFV line valve, which saves considerable space. (See Figure 5-5, Keyed Note 4.) SPU crews can then plumb the bypass from corp-to-corp with copper fittings and tubing to perform the filling function as needed.

2) Modulating (Throttling) Valves

Modulating (throttling) valves are suited for operating in a partially open position. They typically have an automatic actuator governed by a measured parameter such as pressure, flow rate, or elevation. SCADA control or local / remote manual position selection is also used to control modulating valves. A modulating valve’s percent open is adjusted as needed in response to changing system conditions measured either upstream or downstream or both to produce a desired outcome in form of water pressure, flow rate or water surface levels.

Remote control valves are modulating valves that have various applications within water system facilities. Principally, they are used to control water flow from a higher-pressure water source to a lower pressure receiving pipe that in turn supplies a pressure zone. Remote control valves are able adjust their percent open between fully closed and fully open using an actuator whose position is set remotely via SCADA. Remote control valves are normally powered by an electric motor, though other actuator styles also exist depending on electric power availability, valve location, and control requirements. Many applications require the control valve to throttle for long periods. Owing to its suitability for throttling and low operating torque requirements, metal-seated ball valves are the preferred valve type for use as a modulating remote-control valve.

PR valves (also referred to as pressure regulating valves, regulating valves, PRGs, or pressure regulators) are globe style bodied modulating valves that permit water flow in

one direction only, acting between an upper service zone or pressure source to a lower pressure zone. It closely controls the rate of water flow through small changes in the valve's position. The valve's position is driven hydraulically by the difference in upstream and downstream water pressures acting upon opposite sides of a flexible diaphragm that moves away or toward the valve seat as needed to maintain the set pressure. The diaphragm is attached to a disc via a valve stem whose height over the valve seat is controlled by the movement of the diaphragm. The variable space between the disc and the valve seat creates a continuously variable resistance to water flowing past the seat. PR valves are designed for the severe application of passing high flow rates together with high pressure drops while minimizing internal wear.

However, under some flow rate/pressure drop conditions, cavitation may occur. Operating in these regions will shorten the valve's lifespan and should be avoided. CLA-VAL produces an anti-cavitation model designed to minimize the damaging effects of cavitation. The anti-cavitation model combines the internal workings of the design valve size with a valve body size that is the next pipe size larger. For example, a 6-inch Series 600 PR valve will have an 8-inch valve body. The effect is that, when cavitation occurs in the valve, the vapor bubbles collapse harmlessly because they are surrounded by water and not next to the valve body's seat or metal components.

Globe valves can be configured to control many different applications using control pilots that measure pressures upstream and downstream of the valve and adjust the pressures on the diaphragm to produce the desired regulating function. PR valves continuously and automatically respond to pressure changes in the system. They open and close as needed to maintain the set pressure or function for which they are designed.

Due to SPU's investment in trained maintenance personnel, large stocked inventory of replacement parts, and regular on-going maintenance schedule for all PR valves, SPU only installs PR valves manufactured by CLA-VAL. SPU uses only stainless-steel pilots, strainers, adjustable and non-adjustable orifices, and pilot-connecting tubing. SPU maintenance personnel install the pilot systems on all PR valves and set them to function as needed. Contractors only furnish the valve body without pilot systems as specified in City Standard Specifications section 9-30.3(11).

PR valves can be further broken down into the following common regulating functions using specific configurations of globe valve pilots:

- PR valves that are designed to maintain a set pressure downstream of the valve regardless of upstream pressure are called *Pressure Reducing Valves* (see a specific application below). Pressure Reducing Valves are sized to pass the maximum required flow rate while remaining at or below the manufacturer's recommended maximum flow rate. However, large Pressure Reducing Valves cannot control both downstream pressure while also passing low flow rates like those commonly associated with a diurnal demand curve. This condition causes PR valve instability and surging within the upstream and downstream service zones and is to be avoided. Therefore, large Pressure Reducing Valves that meet the maximum demand while maintaining the downstream pressure set point are commonly paired with one or more smaller Pressure Reducing Valves that handle the low flow rates. These parallel valves have downstream set points

that differ by 3 to 5 psi. The smallest parallel valve will be set to maintain the highest downstream pressure set point, which matches the service zone pressure. If the smallest valve cannot keep up with the service zone demand, the pressure loss through the valve increases and the pressure in the service zone begins to drop. When the service zone pressure drops to the set point of the next larger valve, it will begin to open, and the system demand will be shared by both PR valves. This process of shared flow rate continues for as many legs as are in the PR valve station that are needed to meet the maximum service zone demand and pressure requirements.

- PR valves that are designed to maintain a set pressure in the upstream side of the valve while passing as much water as possible to a lower pressure zone are called *Pressure Sustaining Valves*.
- PR valves that maintain a set downstream pressure, if possible, while simultaneously being prioritized to maintain a minimum upstream pressure is called a *Combination Pressure Reducing and Pressure Sustaining Valve*.
- PR valves that are designed to maintain a set downstream or upstream pressure while limiting the maximum flow rate through the valve are called *Rate of Flow Control Valves*. This function is very useful if the head difference is high between the upstream service zone and downstream service zone and the PR valve size is known to be incapable of maintaining a set downstream pressure. If rate of control is not used in this condition, the PR valve will quickly be destroyed by high water velocity through the valve while trying to meet the downstream demand.

Summarizing some key points above:

- Size the valve based on both maximum expected normal flow rate and the minimum expected flow rate. Then check to see that the intermittent maximum flow rate is not exceeded for the valve. A valve that experiences too low of a flow rate will chatter, causing rapidly fluctuating pulsations in the system. A valve with too high of a flow rate will wear prematurely and may cavitate. A valve with an intermittent maximum higher than recommended can experience valve failure.
- Use parallel PR valve legs of differently sized valves that sequentially open for control across all expected flow rates and pressures.
- PR valve bodies are furnished by contractors, and SPU crews install stainless-steel pilot systems and set them to function as needed.
- Check that the valve is suitable for the maximum differential pressure expected.
- Check that the valve is not expected to cavitate under any operating conditions. If cavitation is expected, CLA-VAL has a Series 600 model PR valve that reduces damage from cavitation.

Tip: Consider installing PR valves at the lowest elevation possible. On the other hand, PRVs should be installed as high in the pressure zone and as near the PR valve as possible, to minimize the difference in pressure across the valve. This reduces wear on the PRV seat and leads to better PRV performance and lower pressure surges. Consider also that sites in environmentally critical areas (ECAs) may not be compatible with PRV discharges.

Pressure relief valve (PRV): SPU uses the formal application of the abbreviation PRV to refer to pressure relief valves. Pressure relief valves employ the same globe valve and hardware as used in a PR valve, but with a different configuration of its control pilot piping. A PRV continuously and automatically responds to changes in inlet water pressure. A PRV will release water if its set pressure is exceeded. **Wherever a service zone is supplied by a PR valve, a PRV must also be provided to protect the lower service zone from excess pressure that could accompany a malfunction of the PR valve.** A PR valve can malfunction at any time. If that happens:

- The PR valve may fail wide open, which is analogous to a direct connection from the upper service zone (SZ) to the lower service zone through a minor head loss.
- A large increase in pressure in the lower service zone results from a PR valve failure, which is injurious to customer and public piping systems. This pressure increase is the difference between the upper service zone's pressure at the PR valve and the lower service zone's pressure at that location and is labelled ΔP_{PR} .

To size the PRV, the required flow rate and appropriate pressure differential is needed, which leads to the calculation of the required PRV's valve coefficient, C_v . A quick rough analysis may be obtained through the following steps:

1. The calculation of the maximum **increase** of flow through a PR valve during a failure begins with knowing (or assuming) the minimum flow rate for the PR valve in gallons per minute (gpm). This is because failure can happen at any time, including low demand periods in the system's diurnal curve when the systems' pressures are typically highest; this is the worst-case failure scenario.
2. Obtain the maximum normal pressure differential between the two service zones, (ΔP_{PR}). This can be quickly done by subtracting the lower service zone's maximum hydraulic grade in ft from the upper zone's hydraulic grade in ft and dividing by 2.31 ft/psi. For example, a PR valve between the 585 SZ and the 480 SZ would be $(585' - 480') / (2.31' / \text{psi}) = 45.4 \text{ psi}$.
3. Obtain the PR valve's C_v from the manufacturer's published literature.
4. Knowing C_v and ΔP_{PR} , calculate an initial maximum flow through the PR valve:

$$Q_{\text{gpm}} = C_v * \text{sqrt}(\Delta P_{PR})$$
5. Subtract the minimum flow rate in step 1. The result is the flow rate that the PRV should remove from the lower service zone to protect the pressure there. Understand that when water at this flow rate is removed from the lower service zone, the water goes somewhere. Part of PRV design includes providing a safe means for disposing of this flow rate.
6. Determine the pressure differential that the PRV will experience, (ΔP). Use the lower service zone's normal maximum pressure at the PRV site, which may be different from the PR valve site due to a difference in the locations of the PR valve and PRV, though they should be as close as possible. The PRV will usually,

though not always, discharge to atmospheric pressure so ΔP is typically just the PRV site pressure (ΔP_{PRV}). Consider though that piping required to route the discharged water to a safe location may produce back pressure at the PRV, which should be subtracted from the lower service's normal maximum pressure. This may require iterations of calculations.

7. With the flow rate (Q_{gpm}) and the pressure difference (ΔP), the minimum required valve coefficient (C_v) for the PRV is calculated: $C_v = Q_{gpm} / \sqrt{\Delta P}$.
8. Select a PRV size where C_v is at least as high as the one calculated in Step 7.

The steps above lead to a rough solution using assumed worst conditions and will result in the required PRV size capable of handling the flow rate. If the resulting required PRV C_v is near a smaller PRV's C_v , or if significant small diameter pipe with rough walls is present in the PRV source piping or discharge system, the analysis should be refined using hydraulic modeling due to the influence of head loss.

Pressure reducing valves are 2-inch and smaller valves owned by customers to reduce high pressure in the water main to 80 psi (or lower), as required by the building code. Small pressure reducing valves use adjustable spring compression in opposition to the force produced by domestic water pressure acting on a diaphragm to control globe valve position. As the customer uses water, the pressure in the domestic piping decreases to a point where the spring pushes the valve open to provide the demand at the set pressure. Pressure reducing valves are sometimes informally referred to as PRVs, which may cause confusion with pressure relief valves. To avoid confusion, this chapter uses PRV to refer to pressure relief valves only.

Pressure release valves are 2-inch and smaller modulating valves that are owned by customers and are similar in function to pressure relief valves discussed above, except on a much smaller scale. When the small spring in these valves is overcome by domestic pressure higher than allowed by the plumbing code, the valve will open and discharge water to the ground or drain on private property. Where SPU water main pressure exceeds 80 psi, customer-owned pressure reducing valves are necessary to protect interior plumbing from either failure of the customer's pressure reducing valve or a condition caused by water expansion in the hot water tank not being able to escape the domestic plumbing, which causes increased pressure. Pressure release valves are sometimes informally referred to as PRVs, which may cause confusion with pressure relief valves. To avoid confusion, this chapter uses PRV to refer to pressure relief valves only.

3) Check (Non-Return) Valves

Check (non-return) valves are designed to permit water flow in one direction only. They open automatically when the pressure on the receiving side of the valve drops below the inlet side of the valve. They close when the downstream pressure matches the inlet pressure.

Check valves have a variety of functions in the water system facilities. Within the transmission and distribution system, check valves have five common uses: Backflow Prevention Valves, Pump Discharge Check Valves, Purveyor Meter Check Valves, Source Selection Check Valves and Service Zone Boundary Check Valves.

Never mount a check valve in a vertical pipe. This is tempting in pump stations where space can be saved, but debris can build up behind the moving elements and prevent it from opening fully which in turn causes increased head loss and degraded system performance and in some cases a loss of check valve sealing capability altogether.

Check valves are mechanical equipment with automatically moving parts that need to be maintained. Therefore, check valves are never direct-buried and are always installed inside a chamber or building for ready access; they are never direct-buried. They are always bracketed upstream and downstream with isolation valves to permit inspection. For this reason, always provide a means to dismantle the pipe run between the isolation valves.

Backflow prevention valves are check valves that separate the SPU potable water system from non-potable systems to prevent cross connection contamination.

Pump discharge check valves act quickly and automatically on pump discharges to prevent return flow through the pump in the event of a power loss. Non-slam characteristics are essential in check valve selection for this application. The check valve size is selected to match the pump discharge. It is always the next size larger where the pump discharge connection is a non-standard water main size. For instance, a 5-inch discharge would be increased to 6 inch and then a check valve would be next. It is best to sandwich the check valve between the pump and the pump control valve, if there is one. Both the pump control valve and the check valve should be located between isolation valves to permit inspection and maintenance of the pump, control valve and check valve in the same shutdown.

Purveyor meter check valves are placed inside a vault after SPU's metering equipment and before SPU's isolation valve closest to the service union, which is outside the vault. This ensures that all metered water belongs to the customer and cannot return to SPU's system if the pressure reverses for any reason. Placing the check valve before the isolation valve allows SPU to maintain the valve without requiring the purveyor to depressurize and drain his system.

Source selection check valves are used on the downstream side of branch valves attached to outlets on transmission mains and certain feeder mains. In this application, check valves ensure that distribution pressure zones are supplied first from distribution storage. If demand in a distribution service zone pulls the pressure below that of an adjacent supply main, the check valve on the branch connection to the larger main will open. Flow from the transmission or feeder main will help the distribution pressure zone meet demand and help to prevent pressure in the zone from falling further. In addition to reducing the need to construct additional distribution supply, check valves on large main outlets also simplify the process of shutting down large feeder or transmission mains by automatically eliminating reverse flow from the distribution grid mains into the supply main.

Service zone boundary check valves are sometimes installed as the separation device between two adjoining service zones instead of a DV. If fire demand or other large water demand inside a higher-service zone requires immediate supply augmentation from a neighboring lower-service zone, a service zone boundary check valve can automatically open to supply the temporary increased demand. The resulting flow into the higher service zone may be at an undesirable pressure for normal domestic service,

but the inflow can significantly increase the flow available to a fire pump. The service zone boundary check valves can only work where the two adjacent service zones are relatively close in hydraulic grade and usually makes sense at locations that are farthest away from the service zone's source and are fed by small mains or mains with high friction characteristics. Modeling the performance of the two adjacent systems together is the best way to determine if a service zone boundary check valve is needed.

When immediate and automatic supplementation of the higher-pressure zone is not crucial, check valves between zones should be avoided. By its nature, a zone boundary check valve prevents emergency water transfer from the higher-pressure zone into a lower-pressure zone.

A DV facilitates emergency water transfer between zones in either direction. Though a DV is the preferred pressure zone separator, a check valve may have a role in correcting low fire flow conditions at specific hydrants, or when an instantaneous back-up supply is desired for zone normally supplied by a single source vulnerable to sudden loss (see Figure 5-7).

Figure 5-7
Pressure Zone Boundary Check Valve Co-Located with Fire Hydrant

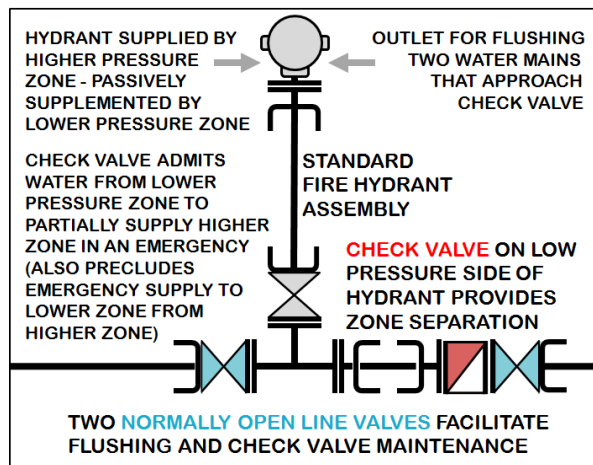

4) Air Valves

Air valves are devices that permit or restrict the movement of air, under a controlled manner, into or out of distribution mains, feeder mains, supply mains, and transmission mains as well as some other appurtenances such as pump casings and pump discharge pipes. The amount and type of air control varies according to the design function required. Air valves function automatically in virtually every application, and they do so without the need for any external power source. **However, they do require regular maintenance and must be installed inside a chamber; they are never direct-buried.**

By their nature, air valves are a potential pathway to cross-connection contamination. They are designed to physically separate the potable water environment inside the pipe while admitting air from, or releasing air to, the non-potable environment. Installing them improperly can enable non-potable water or other contaminants into the potable water system.

To prevent cross-connections, Washington State DOH regulations do not allow air valve vent piping to terminate inside a chamber. This practice from many years ago has been permanently discontinued. **For this reason, air valve vent pipes must be plumbed directly from the valve outlet to above the ground surface. The air valve vent pipe must terminate at 18 inches or more above ground surface where no flooding is expected and where flooding can occur the termination must be at least two pipe diameters above the 25-year flood plain, or greater depending on-site conditions.**

Air valves inside pump stations or large valve stations may terminate inside a building provided the building is ventilated, there is a primary sump pump with a back-up sump pump, and there are alarms to OCC with power back-up for conditions such as power loss, sump pump failure, and two sump high water levels. This level of equipment and instrumentation normally only occurs inside major facilities containing pumps, motor control equipment, electronics and other equipment that cannot endure the presence of standing water or high condensing humidity.

Air valve functions and design are covered in depth in AWWA Manual M51.

SPU makes use of fire hydrants and frequent water service connections to supply and exhaust air during draining and filling procedures of shutdowns involving most distribution water mains.

Air valves are required on transmission mains, feeder mains and distribution mains lacking hydrants and/or water services at profile high points.

Air and vacuum valves (AVV or large orifice air valve or air/vac valves) represent the minimum requirement for air and vacuum management in mains requiring autonomous large air supply and vacuum relief provisions. AVVs are placed at high points along the water main's profile. They permit large-volume admission of air during the draining of a pipe, thus preventing harmful negative pressure (vacuum). During the refill of a pipe, an AVV remains open to allow a large volume of air to escape that is being displaced by incoming water. During filling, the pipeline experiences only minor pressurization due to restrictions while air is exiting AVVs. Hence it is very important to refill large pipe at a slow enough rate such that when the final air pocket is expelled the hydraulic transient (unsteady flow, also called water hammer) is not excessive.

When the water level reaches the crown of the pipe at the crest of the pipe profile, water will enter the AVV body, and a float inside the valve will seal off a large orifice at the AVV's discharge opening. When the float seals the large air valve orifice, the valve cannot re-open while there is water in the valve or while the pressure on the inside of the pipe is higher than atmospheric pressure. This is another reason to refill pipelines slowly. Some AVVs have a tendency to blow closed during filling, and once this happens, there is no way to reopen them again unless the refilling is halted and the minor interior refilling pressure is taken off the pipe. In short, AVVs operate fully open or fully closed. Once closed, an AVV will remain closed, even if air from the shutdown operation begins to accumulate at the high point. Furthermore, AVVs cannot discharge air that may accumulate after being entrained or dissolved into water passing through the pipe after it has closed.

Air inflow at AVVs under some conditions has such a high velocity that a condition termed *choked flow* occurs. This condition happens when the pipeline internal pressure approaches 0 psia and is an unusual condition. In this condition, the Mach Number

approaches one and the atmospheric pressure can no longer increase the airflow rate since the air experiences both restrictive head losses and expansion as it passes through the valve's air passages. When choked flow occurs, the air velocity has reached the sonic velocity through the valve and it sounds very loud like a jet engine roar, which is unacceptable in neighborhoods. To limit this, the location of the highest velocity and intensity of sound is inside a vault where the air valve is located. The vent pipe is increased after the discharge pipe near the air valve and the highest velocity noise will not occur in the neighborhood environment.

Also, to help minimize the possibility of choked flow happening, AVVs are sized to admit air at the maximum expected draining flow rate while maintaining no more than 5 psig differential between atmospheric pressure and pipeline internal pressure. Consult the air valve manufacturer's literature to determine the correct size for the application under design. This 5 psig differential is also important because high-vacuum conditions can deform gaskets of ductile iron pipe joints or even suck them into the pipe, which disrupts their ability to contain water under pressure.

Air release valves (ARV or small orifice air valve) are air valves that open to expel small accumulations of air when the main is under full pressure, but they are not designed to exchange the large volume of air that accompanies water pipelines draining and refilling that AVVs can pass. ARVs supplement AVVs along lengthy horizontal runs between high points where long runs of pipe accumulate entrained or dissolved air, which effervesces as the pressure decreases at local high points. However, there are applications where an ARV is not paired with an AVV at a local minor high point. Thus, the design of the air valve orifice size becomes important.

ARVs have floats that rise when the air valve body is full of water. When the float rises, stainless steel links and/or levers place a small pad of rubber across a small orifice at the valve's discharge. When air enters the valve body, in an empty pipe, the pipe fill rate may experience a nearly unrestricted resistance at first, but the pipe will begin to pressurize slowly because the fill rate is nearly always higher than the ARV's designed discharge rate. This is somewhat different from a large orifice valve.

At some point during filling, the water levels on both sides of the local high point will connect and the remaining cavity of air will be released until the pipe is full, and water will enter the ARV body at a high rate of speed. This is because the viscosity of air is so much lower than that of water (about $1/15^{\text{th}}$). Air will leave the valve very abruptly and water replacing the air will enter the valve body under a considerably high velocity.

Water entering the valve will raise the float and when the float shuts the air orifice, the water comes to an abrupt halt and hydraulic transients will form in the pipeline. The high pressure associated with water hammer is partially due to the change of flow velocity in the pipe, not in the valve body. If the air cavity in the pipe is exhausted slowly, the transient pressure will be low.

In rough terms, a 1 ft-per-second (fps) change of relative velocity of water is sufficient to cause a 40-50 psi pressure rise in most steel or ductile iron pipes. The air valve's orifice is designed to allow the internal water pressure to force the air out in a controlled squeezing effect. An oversized orifice will allow the air to leave more quickly under the same pressure conditions as a smaller orifice. As a result, the manufacturer's literature should be consulted for designing ARVs.

The design literature will rate the ARV's air outflow rate in standard cubic ft per minute (SCFM) at specific pressure differentials. The ARV's discharge rate should be selected such that the pipe is filled under a slow enough rate to minimize water hammer. To do this, first realize that in the final stage of filling, the water will be approaching the high point from possibly both directions and it is the relative speed of bubble collapse that matters in pressure transients.

Select the design relative velocity (two water columns joining) of filling rate in fps and calculate the pipeline cross-sectional area in square ft. The compressed air flow rate out of the valve can be calculated as Velocity X Cross Sectional Area.

Convert compressed air flow rate in cubic ft per minute (CFM) at the assumed pipeline temperature to SCFM under standard conditions by the relationship:

$$SCFM = CFM \times (internal\ pressure, psia \div 14.7psia) \times (528^{\circ}R \div pipeline\ temperature)$$

$$\text{Where } ^{\circ}R = (^{\circ}F - 32) + 491.67$$

And where most pipeline internal temperatures are near $50^{\circ}F \pm 5^{\circ}F$

Then using the manufacturer's literature, select the orifice size that matches the pipeline's pressure and SCFM requirement.

Combination air valves (CAV) are air valves that function as AVVs during pipeline filling and function as ARVs once the large orifice has closed and the pipeline is pressurized.

Choked flow provisions of AVVs must be designed. The ARV side of the air valve adds the ability to continue to expel air that may accumulate at the high point after the AVV has closed. CAVs are also appropriate for mains that connect with laterals that do not have complete air release provisions and are advised for mains with long subtle increasing profiles where air can accumulate along the crown of the pipe.

Vacuum valves (VV) are air valves that are used where the primary concern is automatically admitting large amounts of air into the pipe to prevent damaging vacuum conditions from developing during negative pressure transient events. The highest possible air inflow rates, such as pipe break scenarios, should be used to size VVs. Choked flow provisions of AVVs (see above) are essential. Some VVs employ an automatic check disc to release the admitted air in a slow controlled manner when positive pressure returns to prevent high pressure spikes upon regaining the full pipe condition. Other VV designs trap the air once it enters and will not release it. Where this occurs, a separate CAV or ARV will often be placed at a nearby location to release the trapped air. VVs are designed in conjunction with a transient analysis and are designed for the specific pipeline's transient characteristics.

Vent pipes must be installed so that they have a constant upward slope toward the vent pipe opening.

To prevent cross connections, the Washington State DOH requires the air vent piping on the discharge (atmospheric pressure) side of every air valve to discharge above ground and above the 25-year flood plain. This is accomplished through an above-ground standpipe assembly comprised of a vent pipe inside a protective casing. Where possible, SPU requires the vent pipe to be at least one nominal pipe size larger than the size of the air discharge port on the air valve. This reduces the potential of high velocities and

resulting noise at the point of contact with the neighborhood environment and it reduces airflow friction losses, which hinders the air valve’s performance.

Where the standpipe assembly is exposed to traffic collisions, the assembly must include a base breakaway feature that will protect the air valve from damaging forces and structural deformations that may be imposed on the standpipe assembly during a collision or other mishap.

The above-ground portion of the standpipe assembly must also be designed to prohibit vandalism and the ability to introduce contaminants into the air valve’s vent pipe. One method that has worked well is to place the vent pipe inlet inside a much larger diameter casing with heavy screens welded to the inside of the casing at openings. With the top of the screened openings located 12 inches to 18 inches below the top of the casing, the air inlet would be located above the heavy stainless-steel screen by several inches and be supported laterally inside the casing in a manner that puts the vent pipe’s entrance out of reach of tampering. The top of the casing is closed with a heavy plate welded to the casing pipe and the base is bolted or otherwise secured to a concrete slab or vault top in a manner that allows maintenance to be performed while prohibiting removal by vandals. Be sure that there is more open area provided in the heavy screen than the vent pipe area. The air will need to flow through the screen and negotiate the annular space between the outside of the vent pipe and the inside of the casing. This will cause air pressure drop and should be kept as low as possible.

The types of valves used in the SPU water system are shown in Table 5-8. For more information on valves, see Standard Specifications section 9-30.3.

**Table 5-8
Valve Uses within SPU Water System**

Use	Type	Typical Sizes	Comments
Line Valve	Gate, AWWA C509 resilient wedge	4” – 12”	<ul style="list-style-type: none"> Typically used for smaller line valves
	Gate, AWWA C500 double disc	4” – 12”	<ul style="list-style-type: none"> Has a very long lead time to purchase, consider having SPU furnish Only ductile iron bodies allowed SPU buys and stocks a supply on a yearly basis due to long lead time Many larger sizes are in the system
	Gate, AWWA C515 resilient wedge		<ul style="list-style-type: none"> Has thinner body Not used for line valves
	BFV, AWWA C504	4”-12”	<ul style="list-style-type: none"> Can be used on shallow mains More head loss than other valves Debris in main can hinder operation Cannot be pigged
	BFV, AWWA C504	16”- 84”	<ul style="list-style-type: none"> Typically used for line valves More head loss than other valves

Use	Type	Typical Sizes	Comments
	Ball, AWWA C507	4"-48"	<ul style="list-style-type: none"> • Excellent closure and throttling characteristics • Very costly • Low head loss • Rarely used as a line valve
District Valve	Gate, AWWA C500 double disc	4"-12"	<ul style="list-style-type: none"> • Always placed in a chamber • Always closed except for emergency supply • Locked out
Backflow Prevention	Check Valve, AWWA C508	4"-16"	<ul style="list-style-type: none"> • Only allows flow in one direction • Several styles available • Check the slam characteristics
Air Release	ARV, AWWA C514	3/4"-2"	<ul style="list-style-type: none"> • Air release through a small orifice
Air and Vacuum	AVV, AWWA C514	2"-16"	<ul style="list-style-type: none"> • Large orifice air valve
Combination Air Valve	CAV, AWWA C514	4"-16"	<ul style="list-style-type: none"> • Allows air into or out of pipe during draining or filling • Performs function of both admitting into and exhausting air out of pipe
PR Valve	Control Valve, AWWA C530	2"-16"	<ul style="list-style-type: none"> • Maintains a constant downstream pressure
PRV		2"-8"	<ul style="list-style-type: none"> • Allows system pressure to increase to a maximum value before opening to release water to prevent further increase of the system pressure
Double Valve Throttling System	Gate, AWWA C500 double disc	4"-8"	<ul style="list-style-type: none"> • Typically, the sacrificial valve in double-valved blowoff
	Gate, AWWA C515 resilient wedge	4" -8"	<ul style="list-style-type: none"> • This valve is a thin-walled Gate. If used, these are typically the sacrificial valve in double-valved blowoff
	AWWA C509 Gate or AWWA C504 HP BFV	4" -8"	<ul style="list-style-type: none"> • Typically, the isolation valve in double valved blowoff
Long-Term Throttling	Ball, AWWA C507	2" -36"	<ul style="list-style-type: none"> • Long-term high head throttling valve • For throttling, use metal seats
	Plug, AWWA C517	4" -8"	<ul style="list-style-type: none"> • Long-term, high-head throttling valve, now they are typically only put on high head blowoffs

Acronyms and Abbreviations

ARV: air release valve

AVV: air vacuum valve

AWWA: American Water Works Association

BFV: butterfly valve

CAV: combination air valve

HP BFV: high pressure butterfly valve

PR Valve: Pressure regulating valve

PRV: Pressure relief valve

B. Valve Placement Strategy within the Water Distribution System

The primary role of line valves in the water distribution system is to execute various alternative water supply paths available in the water system. Gridding and looping features are examples of water supply redundancy designed into a water distribution system to improve water service reliability during water main failure events and maintenance shutdowns. Line valve operation is how a water utility achieves a return on

past redundancy investments when a main segment must be shut down. Without thoughtful line valve placement, the best-intentioned dual or back-up supply schemes can be rendered useless by a single point failure of a water main. When planning valve placement, it is helpful to consider how far water service can be extended under a given main failure scenario, as opposed to minimizing how many pipe segments would need to be shut down to control the failure.

1) Isolation at all nodes in the grid and networks

Place line valves at junctions connecting segments of the distribution grid and at junctions connecting segments of the feeder and transmission backbones, such that each of the converging main segments can be independently isolated.

2) Valve Placement in the Distribution Grid

Provide valves on all mains at grid junctions, for all zoning designations, as shown in Figure 5-8.

Figure 5-8
Example of Valves on All Mains at Grid Junctions

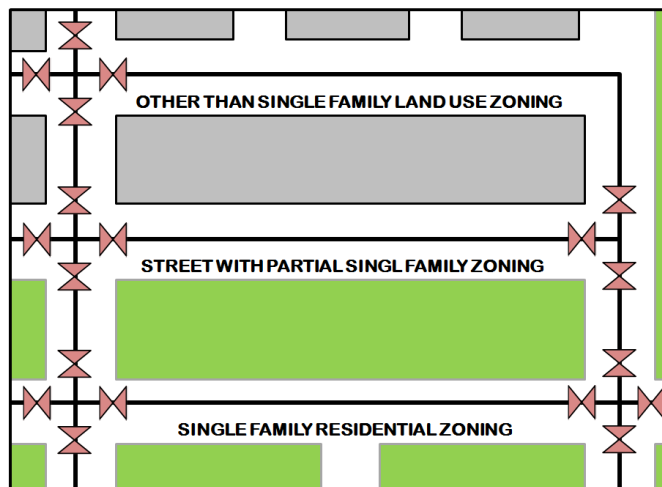

Additional intermediate line valves are required between grid connections, such that any single shutdown segment will be no more than one block or 500 ft in length, whichever is less (except in SFR Zones). See Figure 5-9.

Figure 5-9
Example of Intermediate Valves at Cross Streets

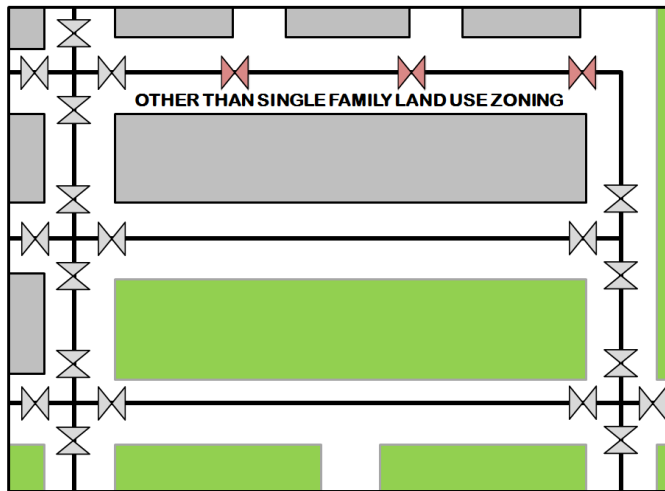

Single-family residential exception: In single-family residential (SFR) zones, line valves are required on all water mains approaching a grid junction. However, intermediate line valves between junctions are required only as needed to create water main shutdown segments not to exceed 800 ft in length. See Figure 5-10.

Figure 5-10
Example of Intermediate Valves in SFR Zones

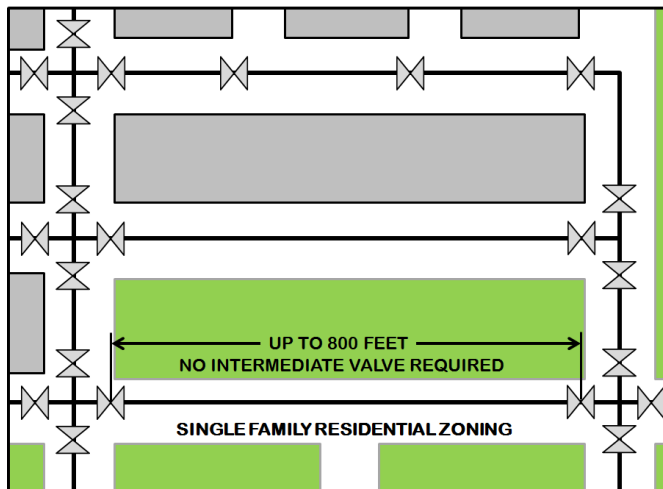

When a street is abutted by properties zoned as single-family residential and properties zoned for use other than single-family residential, use general valve spacing guidelines of one block or up to 500 ft between valves. See Figure 5-11.

Figure 5-11
Example of Intermediate Valve Spacing – Partial SFR Zoning

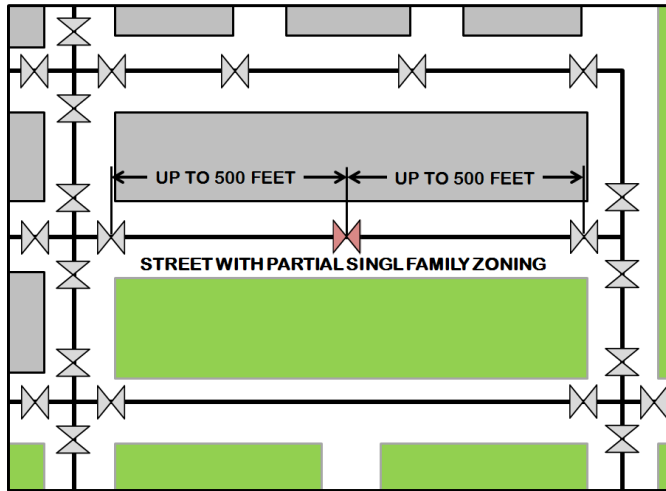

3) Valve Placement along Feeder Mains in the Distribution System

On distribution mains and feeder mains larger than 12 inches in diameter, valves must be located where these mains intersect with other mains larger than 12 inches, such that each of the converging large diameter main segments can be independently isolated. Additional intermediate valves are required between large diameter pipe junctions, such that any shutdown segment of a main larger than 12 inches in diameter will be no more than 1,320 ft (1/4 mile) in length. See Figure 5-12.

Figure 5-12
Example of 1/4 Mile Valve Spacing for Large Diameter Mains

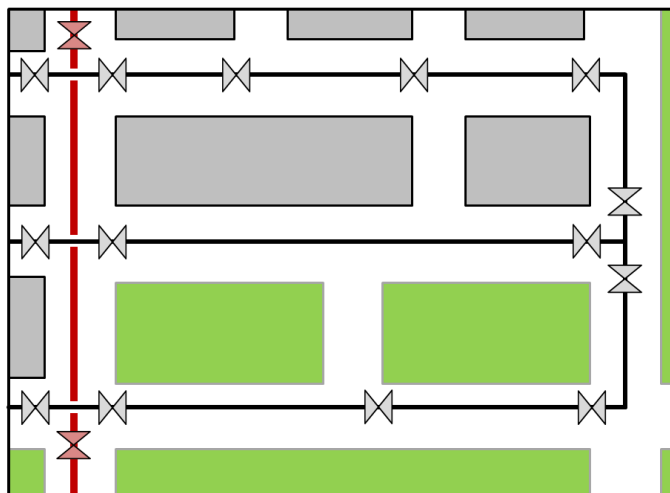

However, if a large diameter main is to be integrated into the water distribution grid, the quarter-mile valve spacing target may be very inappropriate because of its impact on distribution grid shutdown length and outage scope. See Figure 5-13.

Figure 5-13
Example of 1/4 Mile Valve Spacing Not Appropriate with Grid-Integrated Feeder

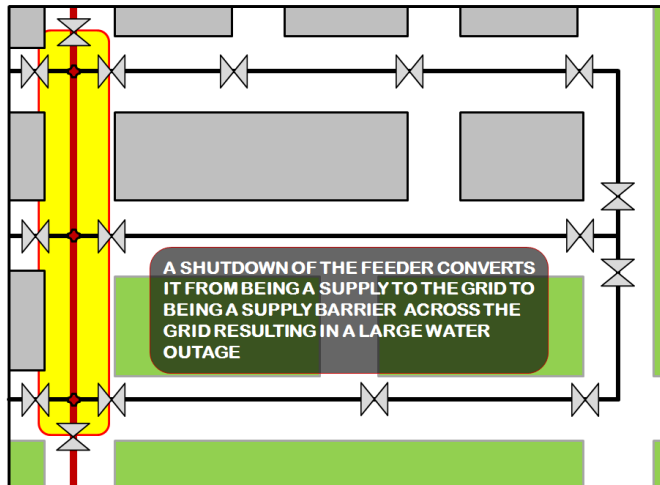

When a larger diameter main interacts with the distribution grid, attention must be given to how potential shutdowns of the large main will affect service to distribution mains, fire hydrants, and water services. Feeder-grid interaction must not defeat the redundancy features incorporated into the distribution grid or increase the shutdown/outage scope experienced by customers served by the grid or served directly off a larger diameter distribution main.

To protect the distribution grid from the effects of less frequent valve placement along large-diameter mains, the simplest modification is to add valves to the larger main to create shutdown segments no larger than what would be allowed for a distribution grid main. Because of the expense and street space required for large (>12") line valves, providing a line valve on each large diameter main approaching a feeder/grid junction may not be desirable. See Figure 5-14.

Figure 5-14
Example of Line Valves Added to Feeder Main

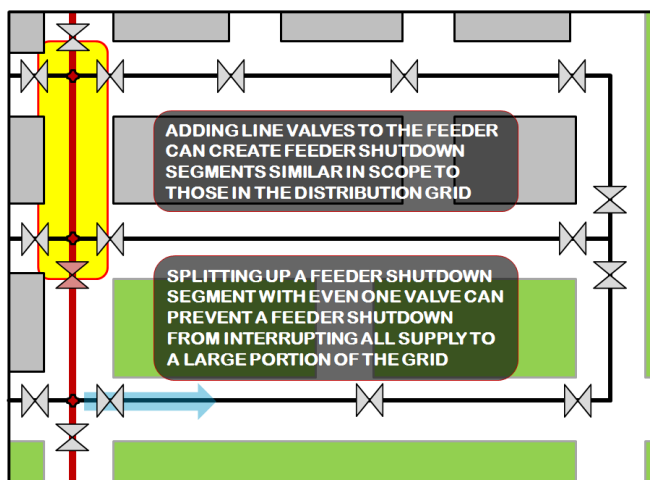

The shutdown/outage implications caused by infrequent placement of costly large-diameter line valves can also be addressed by not fully integrating the large main into the surrounding distribution grid. See Figure 5-15.

Figure 5-15
Main Separation between Feeder and Grid

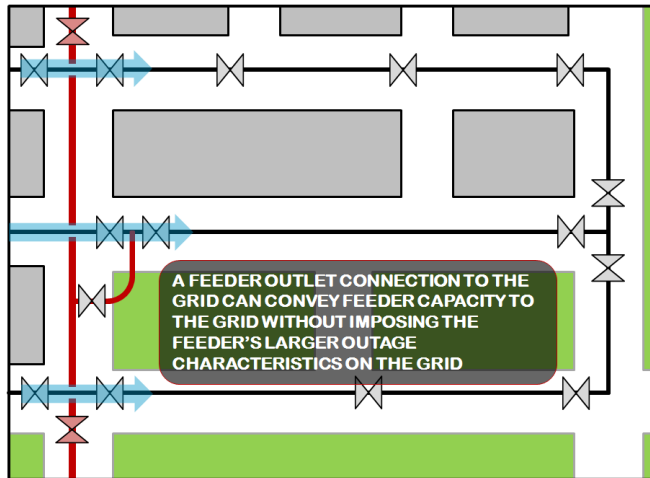

Multiple connections to the grid from different shutdown segments along the feeder can provide the grid with a redundant supply from the feeder that will tolerate a failure and shutdown of the feeder. See Figure 5-16.

Figure 5-16
Example of Improved Reliability from Adding Connections

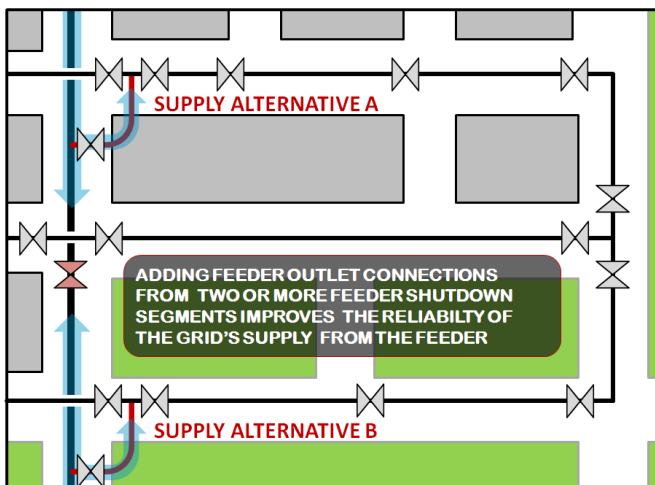

When a large diameter main is fully integrated into the surrounding distribution grid, its higher shutdown/outage implications caused by infrequent valve placement can also be mitigated by avoiding direct customer and hydrant connections to the large main. See Figure 5-17.

Figure 5-17
Local Mains and Water Service Headers to Mitigate Feeder Main Shutdown Impacts

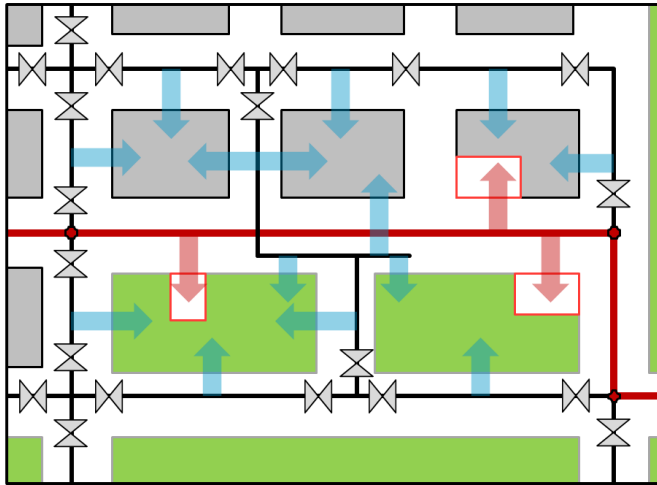

While reducing the number of customers and hydrants supplied by a large-diameter main will reduce the total impact of a shutdown involving the large main, the customers who are affected will experience the lengthier service outage associated with taking a large main out of service. If the shutdown is due to a main failure, repair times associated with a large-diameter main will impose an even greater outage burden on customers directly connected to the large main.

4) Valve Positioning Tactics at Specific Connection Points

The SPU distribution system primarily consists of gray cast iron pipe. Pipe segments and fittings utilize leaded connections, compressed rubber gaskets connections, and pressure-assisted rubber gasket connections. While existing cast iron pipe will continue to provide a long service life, lead joints are subject to hydraulic displacement and leakage, and cast-iron pipe material is subject to fracturing and to pitting and leakage caused by corrosion. When specifying valve positioning at junctions in the distribution grid, keep these vulnerabilities in mind. Avoid valve arrangement that will leave a new supply redundancy feature open to defeat from a single failure involving existing vulnerable pipe.

All-new construction: When a grid junction will consist of all-new construction utilizing standard materials, valves should be positioned at the perimeter of intersections involving arterial streets. When the grid junction is to be located at a street intersection that will also include a fire hydrant, the fire hydrant should be contained within the shutdown zone formed by the perimeter valves. This arrangement allows the fire hydrant to be used for valve seating, flushing, draining, or air/vacuum management involving any of water main segments approaching the junction. The fire hydrant will remain in service under nearly all shutdown scenarios. Future water main repairs within the intersection can be scheduled for low-traffic hours, since pipe in the intersection can be fully isolated without affecting customers. Keeping line valves out of an arterial intersection makes safe valve operation easier, since the operator needs to contend with traffic flow from only one direction at a time. When a grid junction is to be located

in a residential street intersection, incorporating valves into a tee or cross is acceptable if a fire hydrant is not planned for that intersection. See Figure 5-18.

Figure 5-18
Default Positioning of Grid Junction Line Valves for All-New Construction

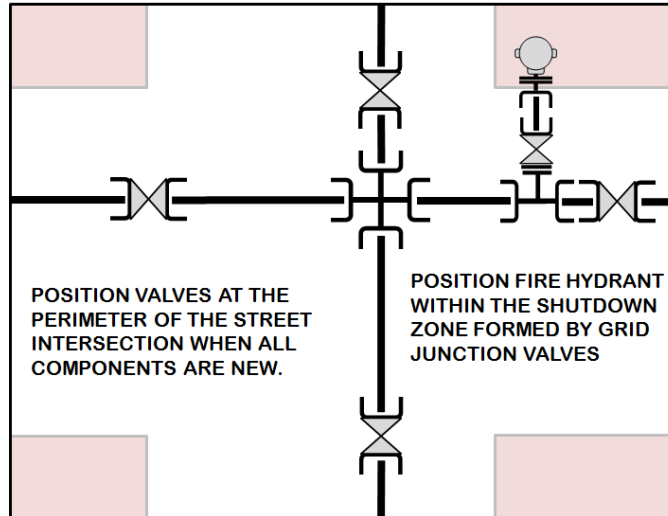

Looped system: When the new water main segment will form a supply loop (will receive water from two directions), then any grid junction created by the new water main can utilize the standard intersection valve positioning practices outlined under all-new construction. The new looped main can employ existing valves and existing cast iron pipe located in the intersection of the new junction. See Figure 5-19.

Figure 5-19
Existing Grid Junction Modification when Connecting New Looped Grid Main

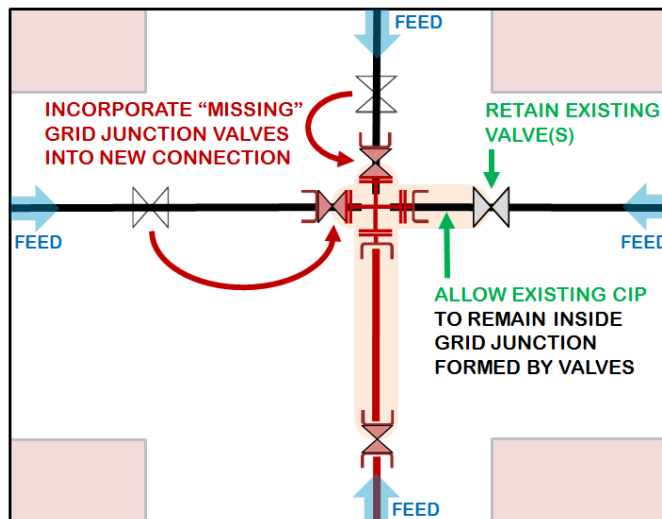

Single-feed system: When the new water main segment will form a dead end, or will provide the only standard-diameter supply to an otherwise dead-end area, the grid

junction needs to be arranged to ensure that the dead-end leg extending out from the grid junction will receive supply from at least to two sources of supply entering the junction. **Pipe and fittings within the valve junction formed by the junction valves must consist of standard materials.** Existing cast iron and lead joint elements should be eliminated. See Figure 5-20 for an example of grid junction reconstruction using ductile iron to ensure dual supply to dead ends.

Figure 5-20
Reconstruction Grid Junction with Ductile Iron

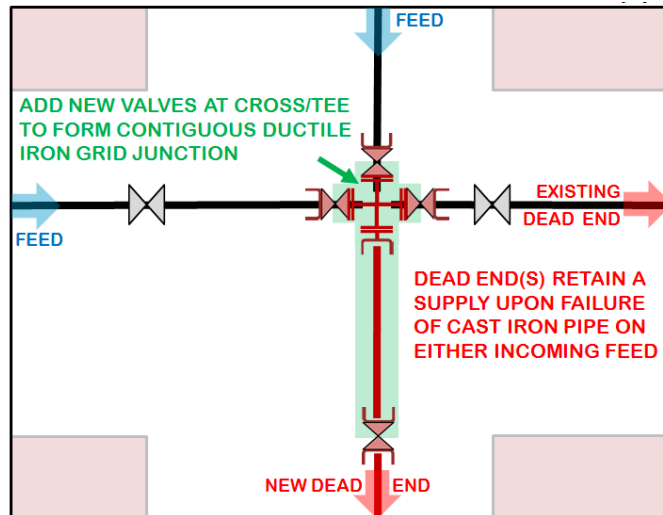

Positioning of line valves not located at street intersections: The emphasis of line valve placement strategy is on using the grid and grid junction valves to keep water delivery options as plentiful as practical. Achieving the goal of insulating as many customers as possible from outages occasioned by maintenance and repair work is generally furthered by placing valves at grid junctions, which are typically located in street intersections. However, in areas with extremely intensive development, a single customer's building may take up an entire city block. The metered water service supplying a large footprint structure will typically be connected to a distribution main offering a one-block or 500-ft shutdown segment. Such relatively tight line valve spacing helps reduce the risk of service interruption caused by water main maintenance and repair. However, as outlined in the valve positioning tactics described above, connection of a new, dead end water main would include the creation of a grid junction capable of feeding the new dead end from either of two sources of supply. In the case of a high-rise residential tower or other large structure, a new water service connection functionally represents a new dead end main. When designing water mains or new water services that support large-occupancy structures, consider positioning line valves on the water main, at each side of the new water service tees that supply the building. Such line valve positioning becomes crucial to service reliability when the water services will connect to an existing cast iron water main that will require continuing maintenance and repair. Creating a gated ductile iron tee assembly for a new water service connection becomes crucial to SPU system operators when the benefiting structure is continuously in operation, as in the case of a hotel. See Figure 5-21 for an example of line valves positioned at service connection points to create two independent feeds.

Figure 5-21
Line Valve Positioning to Create Multiple Independent Feeds

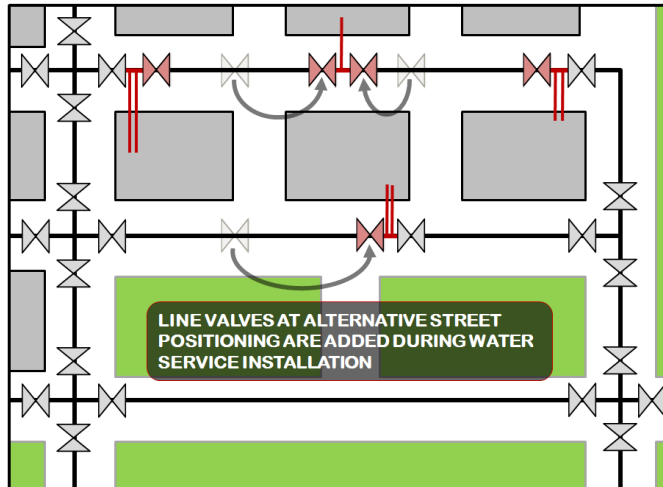

C. Valve Restraint Systems

All valves in chambers and those installed on a RJ pipe and ERDIP should be fully restrained. There are two commonly used options for restraining valves:

- Cement concrete can be used to block buried valves.
- Reinforced concrete collars around the pipe outside the chamber can be used to block valves in chambers, using the chamber wall for thrust restraint.

Valve thrust loads can be transferred to the piping via flanges and MJs using WRGs.

Note: Valves are commonly installed adjacent to dismantling joints for replacement (see below). Dismantling joints can transfer tension thrust loads but not compression thrust loads.

D. Valve Replacement

The design engineer should pay close attention to requirements for valve replacement. Valves that are 16 inches or larger should have an access hatch where the chamber is out of the street or, for in-traffic locations, have a frame and cover directly over the valve. See [Section 5.6.4](#).

5.6.5.2 Access Ports

SPU installs access ports typically on large-diameter (≥ 16 -inch) pipelines.

Access ports provide access during construction and for Operations staff. Typical access port sizes are 24 inches in diameter but smaller ones such as for access during cement lining of welded joints are also possible. Access ports for large transmission mains are typically spaced 1,200 ft apart except in low areas subject to high groundwater tables. Because access ports typically only extend 1 to 2 ft above the pipeline surface, they can be buried or encased in a maintenance hole that extends to the surface. If the access port is fully buried, it should be well documented on the record drawing (as-built) so future Operations staff can find it. If possible, a waterline marker should be installed over, or near, the access port to indicate its location.

SPU typically installs all access ports vertically. In certain cases, a side-mounted access port may be necessary given vertical space restrictions.

5.6.5.3 Air Gap Structures

Air gaps (sometimes called “goosenecks”) are required to prevent cross connections between the domestic water supply and any other liquid. The ultimate function of an air gap is to physically separate potable water from non-potable water contamination. Typically, air gap structures are located on facilities (e.g., tanks) or equipment (e.g., blowoff valves or PRVs) connected to the system. **The gooseneck discharge end must be a minimum of two pipe diameters above ground with a minimum opening height of 12 inches above ground or two pipe diameters above the 25-year flood plain or above a receiving water surface, whichever is higher.** The pipe diameter to use in calculating the discharge height is based on the smallest pipe in the discharge system. Enlarging an air gap discharge pipe to reduce discharge velocity does not mean the gap distance is required to also be increased. On pipeline and tank blowoff valves, air gaps are found at the end of the potable water discharge line.

Piping upstream of an air gap is treated as a potable water line. Piping downstream of the air gap is treated as a non-potable line and must observe the clearances from potable water lines shown in Standard Plans 286a and 286b, unless the DOH risk can be addressed via an engineered solution such as a casing or ductile iron pipe installed to water main standards, including pressure testing or a similar engineered solution. Frame and covers used over openings in air gap discharge chambers use a drain frame and cover per Standard Plan Type 230.

5.6.5.4 Flow Meters

Flow meter selection is covered in more detail in [DSG Chapter 10, Instrumentation & Control \(I&C\) \(Supervisory Control and Data Acquisition \[SCADA\]\)](#). When selecting a flow meter, make sure to follow the upstream and downstream clearances recommended by the manufacturer. In general, there should be smooth straight pipe (i.e., no appurtenances, bends, fittings, or similar) for the equivalent length of 10 pipe diameters upstream of the meter and the equivalent length of 5 pipe diameters downstream. However, some flow meter technologies have overcome the straight pipe-run requirement. Be sure to understand the manufacturer's published literature on this issue.

Always consult with SPU’s Water LOB representative and SCADA system personnel prior to designing flow meters. These teams have already investigated which technologies are available, which ones have suitable accuracy, and which ones have the most promising application for SPU to integrate into the SCADA system.

5.6.5.5 Fire Hydrants

Fire hydrant installations must be in accordance with the current version of the [Standard Specifications section 7-14 and Standard Plans 310a, 310b, 311a, 311b, 312, 313, and 314](#).

Hydrants must be located in areas that are accessible and approved by the Seattle Fire Department, or other fire department with jurisdiction at the hydrant location.

SPU places fire hydrants at specific intervals along standard water mains in the distribution grid. This level of service is intended to provide very general hydrant coverage for all properties abutting a street that is occupied by an SPU standard distribution water main. SPU does not provide hydrant coverage where there is not a need for an SPU water main. SPU does not add extra hydrants beyond those provided by standard spacing practices. SPU hydrant spacing

patterns are intended to benefit the community, and to allow any one hydrant to be placed out of service without creating an unreasonable risk. Consequently, SPU hydrant spacing provides for hydrant frequency that is more generous than required by the Fire Code. **Water main design must include hydrants at standard spacing, even though the specific property constructing an SPU water main may not be obligated by the fire marshal or building authority to install a hydrant.**

To the extent that an SPU standard water main exists and has sufficient capacity, SPU will support property-specific fire suppression needs by installing a fire service or a combination fire and domestic service when purchased by the property owner. The sufficiency of the water main is determined when the owner applies for a water availability certificate. See [DSG Chapter 18, Development Services](#).

A. Hydrant Spacing

Hydrants are to be placed at intersections. Additional hydrants are to be provided as outlined below.

1) Single-Family Residential Areas

- Where intersections are based on a 330-ft street grid pattern, no intermediate hydrant is used between intersections.
- Where intersections are based on a 440-ft street grid pattern, no intermediate hydrant is used between intersections.
- Where intersections are based on a 520-ft street grid pattern, an intermediate hydrant is required when abutting lot depth is greater than 100 ft and is otherwise allowed.
- Where intersections are based on a 660-ft street grid pattern, an intermediate hydrant is required.
- Where intersection hydrants are farther than 660 ft apart, provide one or more evenly spaced intermediate hydrants to achieve spacing targeted at a minimum separation of 300 ft, not to exceed 400 ft.

2) Commercial and Industrial Areas

- Where intersections are based on a 330-ft street grid pattern, no intermediate hydrant is used between intersections. A second SPU hydrant may be installed at an intersection if requested.
- Where intersections are based on a 440-ft street grid pattern, a second SPU hydrant at an intersection or midblock hydrant is required.
- Where intersections are based on a 520-ft street grid pattern, an intermediate hydrant is required.
- Where intersections are based on a 660-ft street grid pattern, an intermediate hydrant is required.
- Where intersection hydrants are farther than 660 ft apart, provide one or more evenly spaced intermediate hydrants to achieve spacing targeted at 300 ft or less.

5.6.6 Rehabilitation of Existing Mains

SPU rehabilitates existing water distribution main either through slip lining the pipe, relining large diameter pipe, or exploring cured-in-place pipe (CiPP), a newer technology. Additionally, cathodic protection can be used to prevent further corrosion of the buried exterior. For detailed information, see [DSG Chapter 6, Cathodic Protection](#).

5.6.6.1 Slip Lining

In slip lining, a pipe of smaller diameter is installed within the original larger pipe. Usually slip lining is performed on distribution or feeder main pipes 30-inches or larger in diameter. The existing pipe becomes the casing for the new pipe. It is often a cost-effective no-dig alternative to traditional open-cut installation of pipe. Typically, slip lining is used as a structural repair. However, it cannot be used if there is substantial damage (crushed or misaligned joints) to the pipe. The annular space between the two pipes is sometimes filled with grout. The design engineer should carefully consider the hydraulic implications of reducing the pipeline diameter. The Water LOB representative may assist in modeling to determine whether reduction in pipe diameter is a viable solution.

5.6.6.2 Relining

If video inspection of the pipeline interior shows significant deterioration of the lining, relining of the pipe may be possible. Pipes are relined by thoroughly cleaning the existing pipe interior then using a machine to spray-coat new cement mortar lining inside the pipe. The method used depends on pipe size. The relining can be designed to strengthen the pipe through use of a structural mesh embedded in the spray-coated cement mortar lining.

The design engineer must consider the additional flushing that will be needed for cement mortar relines. In some past projects the newly relined pipe had a very high pH resulting in taste and odor that required extensive flushing of the pipes during the curing process. Allow time and budget for SPU crews to flush the pipelines, and water quality taste and odor testing.

5.6.6.3 Cured-In-Place Pipe

CiPP is a jointless, seamless pipe-within-a-pipe composite system consisting of a woven polyester jacket saturated with an epoxy resin. CiPP has been installed in cast iron and Kalamein steel pipe in the City. CiPP can reduce installation costs by reducing the amount of restoration work that would otherwise be involved in an open trench installation. CiPP installation has a large mobilization cost and is thus most cost effective when there is a significant amount of pipe requiring rehabilitation. CiPP requires temporary water mains and cut and caps to install.

5.6.6.4 Cathodic Protection

Cathodic protection is one method SPU uses to extend the life of existing water pipelines. For more detail on cathodic protection for distribution and feeder mains, see DSG section 5.6.8 and [DSG Chapter 6, Cathodic Protection](#).

5.6.7 SCADA

See [DSG Chapter 10, I&C \(SCADA\)](#), for SCADA system design. The design engineer should consider whether any monitoring or controls are needed and if the controls should be linked to the system-wide SCADA system.

Coordinate with the Water LOB and SCADA staff to determine which remote-control functions may be needed and which parameters should be monitored. The SPU electrical engineer should be consulted very early in the project design to determine whether power and communication lines are available. If power is unavailable, submitting new power requests to SCL can take up to six months or longer from submission to installation. Thus, early attention to the project's electrical power requirements is essential.

5.6.8 Corrosion Control

Corrosion control of SPU pipelines comes from both active and passive protection systems. Steel pipe, cast iron pipe, and ductile iron pipe will rust when exposed to corrosive soils or water if no protection system is installed. The rate of corrosion depends on the corrosivity of the environment (typically soil or water). The rate of corrosion is mostly a function of how well the environment conducts electrical current.

The internal corrosion of pipes is managed through a combination of water chemistry adjustments (beyond the scope of this DSG), and the use of internal linings.

SPU monitors and controls external (on the soil-pipe interface) corrosion using one of three following methods:

- Testing the soil environment for resistivity
- Applying external bonded coatings or polyethylene film encasements (unbonded film)
- Using a cathodic protection system

See [DSG Chapter 6, Cathodic Protection](#), for detailed discussion of that protection method.

5.6.8.1 Soil Resistivity

Soil resistivity plays a key role in corrosion control of pipelines. Resistivity refers to the resistance of the environment to electrical current flow. It is the inverse unit measurement used to determine conductivity/corrosiveness of the internal or external environment in contact with the pipe surfaces. When the resistivity of water or soil is high, less current can flow through that environment and the rate of corrosion is lower. For external corrosion (exterior surfaces of pipes), soil resistivity is highly variable. For internal corrosion (inside pipes), water resistivity is constant.

For the soil-pipe interface, adjusting soil resistivity is usually neither possible nor practical. Providing select backfill has a short-term effect. Over time, constituents in the soil surrounding the pipe will degrade the backfill and resistivity will approach that of the surrounding material.

Soil corrosivity is based on resistivity measurements of the soil in the pipeline location. Typically, several measurements are taken and an average value is determined. Where soils are very near a classification break point, engineering judgment is required to classify the soil (). Where resistivity tests in one area vary, greater weight is given the more corrosive result(s) (lower resistivity).

See SPU GIS maps for soil resistivity test results and [DSG Chapter 6, Cathodic Protection](#) for corrosion protection requirements for water piping systems.

5.6.8.2 Linings and Coatings

Coating refers to products applied to the outside of pipes. Steel and ductile iron pipelines have different coating requirements. Before selecting a coating system, soil sampling (resistivity testing) should be completed to determine the corrosive nature of the soil.

A. Steel Pipe

All steel pipes must be coated. Several different coating options are available. The design engineer should use best judgment in deciding among coatings. Table 5-9 lists coating types found in the SPU water system in order of use and preference.

Table 5-9
Steel Pipe Coating Types for SPU Water System

Coating	Description
Polyurethane Coating	SPU standard for steel pipe coating. This is a thin film bonded dielectric coating with both water and chemical resistance. It is typically factory-applied and thickness is customized to a specific application. Surface preparation and curing process is very critical.
Fusion Bonded Epoxy (FBE)	FBE is typically applied at the factory on the pipe, and field applied on the joints. Applied by heating the steel pipe, then blowing epoxy in powder form on the heated pipe. Generally considered one of the most durable coatings. Typically, most costly.
Liquid-Applied Epoxy Paint Coatings	Liquid-applied epoxy paint works well with cathodic protection systems. It is resilient and extremely abrasion resistant. Liquid-applied epoxy paint coatings are applied according to AWWA C210 and C218. Commonly used where there is minor damage to the existing coating or the extent of damage is small.
Heat Shrink Wrap Sleeve	Tubular sleeves that can provide effective coating protection around field-welded joints. It is field-applied. Known to be reliable and effective against thermal, chemical, and environmental attack. Economical due to ease of application and no need for primer.
Tape Coating	Historically, this was the most commonly specified dielectric coating system. It has a good performance record at a reasonable cost. Typical application includes 80-mil cold-applied plastic tape in three layers over a properly prepared steel surface. However, tape coatings often dis-bond from pipe when pipe is stored in the weather and in presence of sunlight.
Cement-Mortar Coating	No longer used but may be encountered on existing pipes. Chemically protects pipe from corrosion by providing an alkaline environment where oxidation of steel is inhibited. Can be applied in various thicknesses. Provides mechanical protection against handling and installation damage. Typical application thickness is 1-inch.
Coal-Tar Enamel Coating	One of oldest methods to provide corrosion protection for steel pipelines. Coal-tar enamel is applied over a coal tar or synthetic primer. Application includes cleaning, priming, application of hot enamel, and covering of a fiberglass mat and/or felt outer wrap. Recommended application includes 7/32-inch coal tar with fiberglass reinforced mineral felt with heat-shrinkable cross-linked polyolefin sleeves at joints.

B. Ductile Iron Pipe

Due to its thickness, ductile iron pipe does not always need additional coating beyond standard factory coating. Soil tests should be performed to determine whether additional coating is needed.

For ductile iron pipe, the standard factory coating is an asphaltic coating approximately 1 mm thick. This coating minimizes atmospheric oxidation but provides no in-ground protection.

Ductile iron pipe should conform to Standard Specifications section 9-30.2(1).

Table 5-10 lists ductile iron pipe coating options.

SPU requires a double cement mortar lining thickness for ductile iron pipe. See AWWA C104 for more detail on cement mortar linings for ductile iron pipe.

**Table 5-10
Ductile Iron Pipe Coating Types for SPU Water System**

Coating	SPU Preference
Thermoplastic Powder Coating	SPU standard coating for ductile iron pipe in a corrosive environment. See Standard Specifications section 9-30.1(6)C. Can also be used on steel pipe.
Wax Tape system	When used with appropriate primer and a fiber reinforced outer wrap, this coating can protect any buried metal surface, such as bolts, nuts, rods, copper, ductile, or steel.
Polyethylene film encasement (un-bonded film)	Common application for corrosion control. Acts as an environmental barrier to prevent direct contact between pipe and corrosive soils. Not watertight; groundwater can seep beneath the wrap. Integrity depends on proper installation, careful handling by contractor, and inspection by owner. <u>Polyethylene encasement must be per Standard Specifications section 9-30.1(6) D.</u> SPU has limited success using this product.
Fusion-Bonded Epoxy, Polyurethane, and Tape Coatings	Can be considered as an alternative coating system. Manufacturer has been unwilling to apply bonded coating at factory. Design engineer should recognize potential invalidation of pipe warranty if this is field applied.

C. Linings

Lining refers to a product used to protect the inside of a pipe from corrosion and improve performance and service life. SPU requires a lining for all metallic pipelines. All linings must be [National Sanitation Foundation \(NSF\) 61-approved](#).

Ductile iron pipe is typically supplied with a double thickness Portland cement-mortar lining per AWWA standard C-104, unless otherwise specified. See Standard Specifications section 9-30.1(1).

Welded steel pipe is furnished with two primary lining options: cement-mortar or polyurethane. Cement mortar is a nominal thickness of ¼- to ½-inch following AWWA C-205 recommendations for the pipe size involved. For interior linings, polyurethane thickness is typically around 20-mils. See Standard Specifications section 9-30.1(1).

D. Cathodic Protection

For a pipeline, cathodic protection provides a separate metal known as a sacrificial anode to be the point where corrosion occurs. This anode protects the pipeline from corrosion. By use of either an active impressed current rectifier or galvanic passive materials (zinc or magnesium), the pipeline becomes the cathode and corrosion is transferred to the anode.

If operated at too high of a voltage, cathodic protection systems have the potential to damage coating systems and/or render coating systems less effective. Cathodic protection system design and operation should be considered in conjunction with the coating system and take into account coating type, thickness, extent, and condition.

See [DSG Chapter 6, Cathodic Protection](#), for standards for cathodic protection systems.

E. Environmental Modifications

SPU employs corrosion control techniques such as modifying the pH at its water treatment plants to reduce internal corrosion of water pipelines. This practice is controlled by federal regulation under the [SDWA](#) and EPA's [Lead and Copper Rule](#) and is a water quality operational methodology beyond the scope of this DSG.

Other engineering practices, such as selecting fewer corrosive soils for pipelines and selecting non-corrodible pipeline materials (HDPE, fusible PVC [FPVC], PVC), are design considerations for corrosion control.

5.7 WATER SERVICE CONNECTIONS

For standards and guidelines for water service connections, see [DSG Chapter 17, Water Service Connections](#).

5.8 TRANSMISSION MAIN DESIGN

This section describes transmission main design. Transmission mains are major (16-inch to 92-inch diameter) pipelines within the SPU water system. They convey or transport water from a source to a reservoir and typically do not have any service connections. This section covers the types of materials used, appurtenances, and restraint systems used in transmission main design. For detailed information on water storage tanks, standpipes, and reservoir design, see DSG section 5.9.

Note: This section of the DSG frequently directs the user to DSG section 5.6, Distribution and Feeder Main Design. Many of the elements of transmission main design are identical to those for distribution mains.

5.8.1 Modeling and Main Sizing

See DSG section 5.6.1 for distribution mains. SPU's contracts with its wholesale customers specify the minimum hydraulic gradient or head at each wholesale service connection. The newer wholesale service contracts also specify the maximum flow rate at a given hydraulic gradient that would be provided for each wholesale service connection. Any modification to the transmission system should consider these hydraulic criteria. While these hydraulic criteria may be modified if beneficial to the regional system, SPU may make these modifications only once during any 15-year period, provided that four years advance written notice is given. At a minimum, transmission mains should be sized to maintain a pressure of 5 psi or more, unless the mains are directly adjacent to the storage tanks.

5.8.2 Location

SPU transmission mains are primarily located in the ROW. However, their design is based on least conflict with other utilities and cost of easements. SPU transmission mains within the City are not moved for other utilities, but major regional transportation projects may cause relocations of SPU transmission mains. Outside of the City, SPU generally owns the transmission pipeline ROWs and mains are typically not moved. An exception is some holdings that belong to Washington State Department of Transportation (WSDOT).

5.8.2.1 Separation from Other Utilities

See DSG section 5.6.2.1.

5.8.3 Transmission Mains

5.8.3.1 Minimum Pipe Size

Transmission mains should be sized to carry the designed peak flow required without exceeding the design velocities or head losses. A hydraulic analysis is required before sizing the pipe. Transmission mains typically begin at a water source with a water surface that operates in a limited range and typically end at a reservoir that also operates with a varying water surface through a relatively narrow range. Because of this, designers should perform a hydraulic model over the peak season's flow rates using a several-day analysis to select a pipe size that can reliably deliver the peak demand while keeping the reservoir within the operating range.

Special conditions may call for system redundancy. Providing the capacity to route water through more than one transmission pipe allows service to continue in the event of an outage in a single transmission main. The combination of reliable peak demand delivery, a known energy loss from source to delivery point, and the redundancy paths provided determines the parameters for selecting the pipe size. The fifth edition of AWWA's M-11 chapter 3.3 summarizes the pipe selection this way:

When a limited amount of head loss is available, the smallest-diameter pipe that will deliver the required flow is selected. This results in the least construction cost.

The Water LOB representative may provide the pipe size during project setup. The Water LOB can perform water system modeling to assist in diameter selection. Alternatively, there may be a predesign effort involving the design engineering staff or consultant resources to select the pipe size. This should be determined very early during project start up.

Transmission main design should avoid the use of pump stations, if possible.

5.8.3.2 Material Types

A. Pipe

Water transmission mains are typically constructed of steel or class 52 ductile iron pipe. Both ductile iron pipe and steel pipe are to be cement-mortar lined in most instances (see DSG section 5.6.8.2C). Steel pipe will typically have polyurethane coating. However, see Table 5-9 for additional options.

Note: Although SPU currently manages many miles of concrete pipe of different construction, the difficulty and expense of constructing new outlets, together with the historical failure of some of these pipes, prompted SPU to avoid using pre-stressed and bar-wrapped concrete cylinder pipe for future projects.

See DSG section 5.6.3.1.

B. Casing

See DSG section 5.6.3.5.

5.8.3.3 Pipe Cover

Transmission mains are subject to special pipe strength design considerations and analysis by the design engineer. The minimum depth of cover for water transmission mains is given in the contract for each project. Use AWWA M11 or other applicable design manuals to meet the requirements of the project. SPU typically buries transmission mains with 4 ft of cover to allow smaller utilities to cross over the pipeline and to reduce live load on the pipe.

5.8.3.4 Bedding and Backfill

Large thin-walled transmission mains are very susceptible to vertical deflection due to poor lateral soil support (see Modulus of Soil Reaction, E' in AWWA M11). It is **essential** to keep the trench width as narrow as practical while still permitting compaction at the haunches and sides of the pipe. Over-excavation that causes the trench to widen more than a few percent should be avoided. For clarity of expectations, the installation contract can specify the maximum acceptable trench width, which, if exceeded, should be remedied by placement of firmly compacted structural fill and excavating the trench through the compacted fill.

Bedding for large-diameter, thin-walled steel transmission mains is hard to compact under the pipe haunches. For this reason, SPU has used Mineral Aggregate Type 9, 3/8-inch [Washed Gravel per City Standard Specifications section 9-03.10\(3\)](#). This material is somewhat flowable around the pipe, reaching hard to access areas under the pipe haunches. It is not compacted using standard methods of backfill compaction. Rather, as the pea gravel is placed in lifts, a vibratory stinger is inserted in the narrow space between the outside of the pipe and the trench wall, starting with the first lift under the pipe haunches and proceeding in subsequent lifts of approximately 2 ft in thickness until the full envelope of Class B bedding is placed. The stinger vibration consolidates the pea gravel; it does not compact the gravel. No compaction density tests are performed on the consolidated pea gravel.

Above the pipe bedding, suitable native or imported material may be used for backfilling the trench in lifts of approximately 2 ft in thickness. This material is compacted to 95% of the Modified Proctor Test and may be tested as needed to verify that suitable compaction has been achieved.

Pea gravel is very porous after placement. Therefore, consider using water stops to prevent water from migrating underground through the pipe bedding. Installation of concrete trench cutoffs will help find leaks that may not show up in a long run of pipes with pea gravel backfill.

For example, Figure 5-22 illustrates a trench cutoff example of trench cutoffs see detail 1 on page 42/55 for Tolt Pipeline Number 2 Phase 1 improvements.

Figure 5-22
Trench Cutoff Example

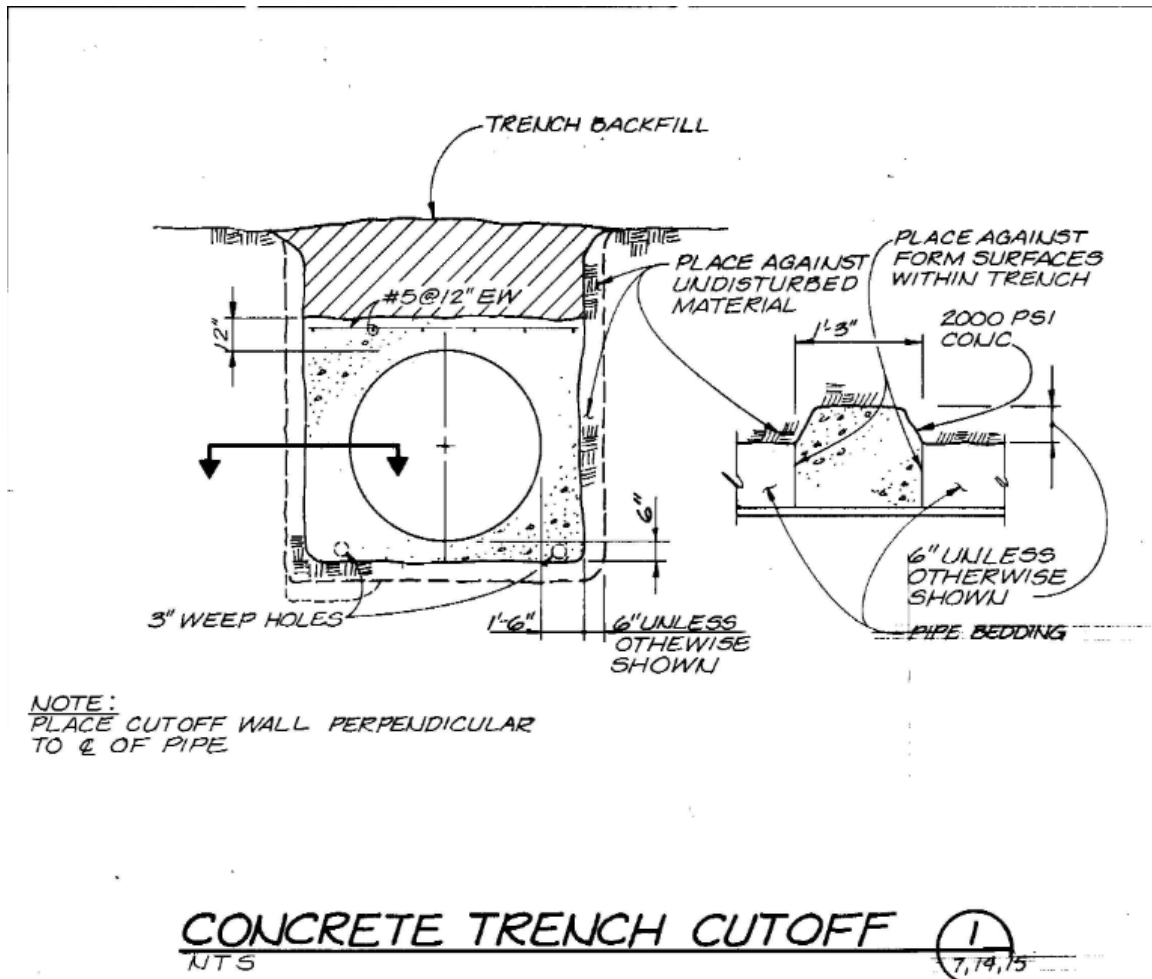

See DSG Section 5.6.3.2.

A. Standard Trench Section

For detail on a standard trench section, see Standard Plan 350.

B. Controlled Density Fill

See DSG section 5.6.3.3B.

5.8.3.5 Line Pressure

Pipelines should be designed to withstand the required internal working pressure, external loads, and transient pressures.

A. Standard Conditions

Transmission lines do not have a typical operating pressure, but rather operate at the pressures available at every location based on the pipeline's energy grade line, flow velocity and elevation. The design engineer should review the modeling results to determine the maximum operating pressure in the pipeline and design the pipeline system for that pressure as the normal working pressure. Transmission mains should not be designed for less than 100 psig. In cases where the pressure varies significantly as the pipeline follows hilly terrain, it may be cost effective to change pressure capacity of the pipeline along the pipeline route by using thicker steel plates for higher pressures and thinner steel plates at lower pressures. Performing quality assurance and quality control (QA/QC) ensures that the correct thickness pipe is installed at the correct locations.

B. Transient Conditions

Transient pressures (also known as surge pressures or water hammer) result from velocity changes in the water flowing through a pipeline. These transient pressures can propagate from any non-uniform flow situation like operating a valve, or an electrical power failure at a pumping facility that causes pumps to shut down, or large abrupt fluctuations in water demand from major users along the pipeline, or a sudden release of entrapped air from the pipeline. There are many methods to control transient pressures, but the study and design of these controls is best left to professional engineer specialists who understand the dynamics of this issue. Increased harm to the transmission system can be caused by applying incorrect methods of surge control.

Each pipeline material has a typical allowance for surge conditions (typically at 1.5 times the pipeline design pressure for steel or 100 psig for ductile iron). AWWA manuals may be of assistance to the design engineer when selecting a pipeline surge allowance. Those allowances should then be compared with the maximum surge pressure from the modeling results to ensure the pipeline can withstand the surge pressure. In the SPU Tolt water transmission system, surges of well over 150 psi have occurred after valves were closed too quickly resulting in burst transmission mains. Occasionally, non-destructive surges of over 40 psi have occurred in commercial and industrial areas.

5.8.3.6 Pipe Supports

Transmission lines should rarely be allowed to run above ground. If that occurs, the design engineer should evaluate temperature differences between the pipe and atmosphere that will affect expansion and contraction at the joints. The issue should be addressed using solutions incorporating expansion joints, pipe insulation, and designing pipe supports to allow movement.

5.8.3.7 Casing

See DSG section 5.6.3.5.

5.8.3.8 Trenchless Technology

Trenchless technologies such as bore and jacking, micro-tunneling, HDD, pipe ramming, and slip lining are alternative methods of construction to the more typical cut-and-cover. Typically, trenchless technology is considered to avoid environmental or construction impacts. Before considering trenchless technologies, the design engineer should rule out alternatives. Every

trenchless project is unique and requires custom evaluation and analysis. Items to consider include topography, soil conditions, regulatory issues, and site constraints (such as available space for jacking and receiving pits).

A. Bore and Jacking

Bore and jack installation (also called horizontal auger boring) consists of installing a casing by jacking and concurrently auguring the soils out through the casing. Alignment is fairly accurate with bore and jacking. However, there can be potential problems with high ground water and excessive lengths. Once the casing pipe is installed, the carrier pipe is installed with spacers to support the pipe. The gap between pipe and casing is usually left open for future water main replacement, and the casing ends are sealed to prevent migration of water and natural gas. However, if the project situation requires it, the annular space can be filled, typically with blown sand or a non-shrink grout.

B. Micro-tunneling

Micro-tunneling is typically a closed-face pipe jacking process. Micro-tunneling requires both launching and receiving shafts, which are typically constructed out of slurry walls. Micro-tunneling machines are laser controlled remotely from the surface. Micro-tunneling is used to install a casing pipe and a carrier pipe follows. Because this process allows precise grade control, it is frequently used in water and sewer applications. End caps on the casing are used and the annular space is usually left open for future water main replacement.

C. Horizontal Directional Drilling

HDD consists of drilling progressively larger diameters from ground surface to ground surface in an arch under the obstruction. No shafts are constructed with HDD construction. Typically, the first pass of a drilling operation, using a small, easily controlled boring tool, creates the route. The pipeline route is then increased in diameter by forward and back reaming the drill path. The hole is kept open with drilling fluids, typically a bentonite slurry. During drilling, various methods are used to track the drill bit and determine the route. Recent history has shown HDD pipeline installation to be relatively accurate. Once the desired diameter is achieved, the carrier pipe is pulled through the drilled path. No casing pipe is used in HDD applications.

D. Pipe Ramming

Pipe ramming consists of using a hydraulic hammer to push the pipe through the soil. Once the casing pipe is installed, the center channel is removed, typically by an auger method or compressed air. With small diameters, the carrier pipe may be rammed with a closed end. Frictional forces can limit the overall length of the pipe ramming, and there is no line or grade control. Thus, this method of installation is best for short lengths of pipe, such as tunneling under streetcar tracks. End caps on the casing are used and the annular space is usually left open for future water main replacement.

E. Slip Lining

Slip lining has been used for installing very long stretches of transmission main. A key component of slip lining is that an existing pipe replacement is needed. The reasons for replacement may vary but usually involve a structural compromise of the existing pipe.

A combination of the following factors may indicate slip lining is a viable installation method:

- When open-cut construction is cost prohibitive or inadvisable because of environmental concerns
- When the existing pipe diameter may be downsized without adverse effects on the water system's flexibility and capacity
- When installation must be performed in a very short duration
- When the existing pipe is large enough for a person to enter and inspect its condition and out of roundness and large enough to transport and assemble the new pipeline inside the existing pipe
- When the radius of curvature of true bends in the existing pipe will allow the new pipe to be transported into place

For an example of slip lining, refer to the Tolt River Pipeline #1 Rehabilitation project, [Project #880056, Plan #68-28](#) (Plan #1068-28 in SeaDIR. Slip lining was used to replace the reinforced concrete cylinder pipe that had lost its structural integrity due to reinforcement corrosion. All of the aforementioned factors were applicable, therefore making slip lining a viable installation method.

5.8.3.9 Restraint Systems

See DSG section 5.6.3.4.

5.8.3.10 Chambers (Vaults)

See DSG section 5.6.4.

5.8.3.11 Appurtenances

Pipeline appurtenances, such as line valves, access ports, blowoff/drains, or ARVs/AVVs should be provided along the pipeline as needed to support the transmission main function and operation. Appurtenance locations should be determined to avoid conflicts with other structures, vehicular traffic, existing utilities, and locations vulnerable to damage or vandalism. See DSG section 5.6.5.

5.8.3.12 Line Valves

Each transmission main project should examine the proposed route for the best location of isolation line valves. Consideration should be given to future operational issues such as draining the pipeline and isolating a mainline break. SPU recommends placing isolation valves at least every 2,000 ft and at every intertie location. All line valves should be installed within a chamber per the standard line valve chamber detail in the DSG (see Figure 5-5).

5.8.4 Interconnection of Parallel Mains

In some cases, multiple transmission mains (pipelines) may be installed parallel to each other, such as Cedar River Pipelines 1, 2, and 3, or a new line may be installed near an existing main, such as the dewatering 12-inch mains on Tolt Pipelines 1 and 2. Interconnection of adjacent pipelines can take the form of large-diameter connections for operational flexibility and small-diameter connections such as interconnection outlets at the spring lines of the parallel

pipelines. The design engineer should consider whether a connection between the two pipelines is both possible and beneficial. The water LOB representative should be consulted to determine whether a large diameter interconnection is desired for operational flexibility, such as the interconnections between the Cedar River Pipelines near South Leo Street.

A primary reason to consider interconnections using smaller diameter pipe is draining of the transmission mains. Typically, when a transmission main is drained, millions of gallons of water are wasted. Pumping from pipeline to pipeline allows for faster draining than can normally be achieved by draining to the wastewater system or a body of water. If parallel or nearby pipelines are interconnected, water from the pipeline to be drained can be pumped into the other pipeline, thus not wasting water. This system is used in some locations between Lake Youngs Supply Lines #4 and #5, between the Cedar River Pipelines 1, 2, and 3 at Black Creek in Renton, Washington, and at the intersection between Beacon Avenue South and Martin Luther King Jr. Way South in Seattle, Washington. Additionally, on transmission mains, an outlet can be installed at the spring line of a local low point (sag) above a blowoff outlet on the bottom of the pipeline. A 12-inch, or other suitably sized main, can be installed parallel to the transmission main from the sag to a point just over the next downstream high point. A pump can be installed between the spring line outlet and the parallel 12-inch main to pump the sag water over the next hill, which will drain the sag faster than a blowoff and drain less water to the local sag's location. This blowoff technique is used on the Tolt Pipeline where the local drainage facilities are very limited.

The interconnection between pipelines will likely require space for a pump. If possible, route the interconnection line from each pipeline into a single chamber, leaving a gap for a pump and the final connecting piping. The size of the interconnection should be based on flow calculations and an acceptable amount of time to drain the line. A good location for an intertie is at the blowoff. The interconnection outlet should be taken off the spring line and not from the blowoff outlet to avoid pumping settled debris off the bottom of one pipe and transferring it to the parallel pipe.

5.8.5 Rehabilitation of Existing Mains

See DSG section 5.6.6.

5.8.6 Emergency Pump Connections

See DSG section 5.11.6.

5.8.7 SCADA

See DSG section 5.6.7 and [DSG Chapter 10, I&C \(SCADA\)](#).

5.8.8 Corrosion Control

See DSG section 5.6.8.

5.9 WATER STORAGE TANKS, STANDPIPES AND RESERVOIR DESIGN

This section describes water storage facility design. Water storage facilities primarily function to provide adequate flow and pressure for all design conditions where the transmission and distribution system cannot otherwise maintain the flow or pressure required. Removed for Security

5.9.1 Planning

Planning includes determining the facility's general characteristics, size, location, and a timeline for service based on hydraulic modeling and demand projections. If approved by SPU management, a storage facility project is incorporated into the Capital Improvement Program (CIP) plan.

5.9.1.1 Service Life

A. Concrete Reservoirs

For new concrete water storage reservoirs, service life must meet the specific project requirements. Most water utilities use a typical service life of not less than 50 years for concrete structures. For refurbished existing concrete water storage reservoirs, the design service life will be established case-by-case based on the specific conditions and requirements for the reservoir.

B. Steel Storage Tanks

For new steel water storage tanks, most water utilities use a design life of 75 or more years, assuming that the coatings are well maintained. An economic analysis of coating and cathodic protection systems should be done to determine the most cost-effective method for preventing corrosion. For refurbished existing steel water storage tanks, design service life is established case-by-case based on specific conditions and requirements for the tank.

5.9.1.2 Hydraulic and Capacity Requirements

Generally, the size of a finished water storage facility must provide sufficient capacity to meet both domestic demands and any requirements for fire flow.

Specific capacity requirements must meet the applicable elements of DOH's 2019 Water System Design Manual ([Appendix 5E](#)) or SPU's system reliability criteria under defined emergency scenarios, whichever is less. Storage facilities are expensive to construct, operate and maintain, plus they increase the water age and as such should not be unnecessarily oversized.

Capacity should be established and documented by an engineering study using the following basic criteria:

- The planning horizon for demand projections should be not less than 20 years. For new facilities, the planning horizon should be 50 years or more.
- Volume should be sufficient to deliver design peak hourly demand at 30 psi to the pressure zone served. This volume requirement may be reduced when the source water facilities have sufficient capacity with standby power for pumping to the reservoir and/or when another storage reservoir can be used to supplement peak demands of the zone. During fire flow conditions, the combination of storage and delivery system capacity must be adequate to provide water at the required flow rate and a minimum 20 psi in the main.
- To determine the emergency/standby storage component, identify the reasonable emergencies, define the duration and level of service during the emergency, then apply SPU's reliability criteria as described in the current Water Supply Plan.
- Water quality impact of storage and design considerations to enable regulatory compliance throughout the life of the facility.

5.9.1.3 New or Modifications/Expansions of Existing Storage Facilities

A. General Considerations for New Facilities

The following are general considerations for planning and preliminary design of new storage facilities or for modifications, expansions, retirements, or downsizing existing facilities:

- Hydraulic grade line (HGL) of the water supply system
- Pressure zones served by the storage facility
- Sizes and capacities of transmission or feeder mains and, where applicable, booster pumping stations, that supply the storage facility (existing and future)
- Sizes and capacities of distribution mains in the pressure zones served by the storage facility (existing and future)
- Availability and type of discharge points for overflow and drain water from the storage facility
- Geotechnical and seismic characteristics
- Vehicle access for all anticipated vehicle and equipment types
- Security
- Fire services (fire flow, emergency engine fill points post-earthquake)
- Land ownership and future use by City departments
- Environmental impacts to adjacent properties
- Multi-use site considerations (e.g., public access, recreation, memorandum of agreement addressing maintenance and use on reservoir sites and sites adjacent to reservoirs)
- Anticipated future development of adjacent properties

B. Communications Equipment

Antennas and other communications equipment can be mounted on a separate tower on the site or on a storage facility. **If antennas or communications equipment are**

mounted on the storage facility, proposals must include structural and wind-load engineering calculations demonstrating the tank can safely accommodate the additional weight of equipment and cables. SPU Real Property is the lead for communicating with tenants and issues the permits for use of SPU property.

Calculations must factor in other equipment already installed on the tank. Equipment should be clamped to the facility rather than welded, when possible, to avoid damage to interior and exterior coatings.

Note: It is extremely important to ensure that the interior coating of the tank is undamaged either by welding or by an activity that may jeopardize the interior lining or the exterior coating. The repair cost of such damage is significant.

C. Location of New Facilities

Location of new storage facilities should consider site features and constraints that affect the sanitary and structural integrity of the facility:

- Drainage of site and structure
- Locate storage facilities at least 50 ft from the nearest potential source of contamination
- For above-grade facilities: foundations should be at least 3 ft higher than the 100-year flood elevation and at least 3 inches above the surrounding ground finish grade to avoid standing water causing corrosion to the steel plates or anchor bolts for the storage tank.
- For below-grade facilities:
 - At least 50% of reservoir or tank should be above highest point of groundwater table
 - Accessible vents and hatches should be at least 2 ft above normal ground surface. Grade should slope away from the reservoir. Access points and vents are located above the 100-year storm elevation
- Proximity to closest sanitary sewer and storm drainage mains
- Overflow route
- O&M requirements

D. Routine Operations

At a minimum, each water storage facility must follow water supply and quality goals for operational procedures common to all facilities, as shown in Table 5-11.

Table 5-11
Sample Requirements for Routine Operation of Water Storage Facilities

Parameter	Requirement	Comments
Pressure Maintenance to Zone Served:	30 psi	Maintain 30 psi under peak hourly demand conditions Maintain 20 psi under fire flow conditions

Parameter	Requirement	Comments
Minimum	20 psi	
Drawdown and Filling	Typical draw between 8 a.m. and 5 p.m. Typical fill between 8 p.m. and 5 a.m.	Draw and fill cycles for some storage facilities may vary from this objective to meet other requirements Note: These times are a starting point. Drawdown occurs during day and fill overnight as a general rule
Water Age (turnover rate)	5–7 days	Longer water ages may be acceptable for some storage facilities based on chlorine residual data, water mixing systems and ease of chemical injection
Operational Volume	As required to meet seasonal demands, pressure requirements, and water age targets	Operational volumes will vary seasonally for many of the storage facilities
Sample Collection	Easily accessible sample port enclosed in cabinet	Sampling may be required at different elevations within the tank
Supervisory Control and Monitoring	Water elevation Overflow indication Inlet and outlet metering Inlet and outlet valve control	
Manual Booster Chlorination at Elevated Tanks and Standpipes	Easily accessible injection port enclosed in cabinet	Injection occurs on fill cycle

Acronyms and Abbreviations

psi: pounds per square inch

E. Emergency Operations

The following are minimum design requirements for operation of water storage facilities under emergency conditions that can result in loss of power or a water quality condition that could be harmful to health:

- Maintain at least one storage cell online if facility has two or more storage cells. If the facility is a single cell, maintain at least 50% of the volume online
- Fill all storage cells
- Draw from at least one storage cell to meet emergency demands
- Hydraulically isolate all storage cells from the supply and distribution system
- Complete drain-down of a storage cell as specified in the basis of design
- Inject a solution of treatment chemical
- Collect a water quality sample from an easily accessible collection point

5.9.2 Water Storage Facility Structures

The following are the primary structural functions of a water storage facility:

- Remain as watertight as achievable for the design seismic, geotechnical, and thermal conditions over its design life
- Survive the design seismic event so that its operational purpose (fill, storage, and draw of potable water) is maintained
- Maintain the sanitary integrity of the tank so that its water quality is not compromised

The following are general design requirements for structural and material design elements of storage facilities to meet the above requirements. All elements must be evaluated and addressed to establish the basis of design for every new or refurbished storage facility.

5.9.2.1 Geotechnical and Seismic Requirements

The following geotechnical and seismic requirements apply to storage facilities:

- A geotechnical study must be performed before design of any new or structurally refurbished storage facility. Soils and groundwater characteristics for each site are unique, so the geotechnical study must be tailored accordingly.
- The methods, findings, and recommendations of the geotechnical study must be documented in a geotechnical report.
- The structural design requirements of storage facilities must address specific seismic criteria for Essential Structures per the Seattle Building Code (SBC) and AWWA D100.

Perform seismic design with considerations for soil-structure interaction.

The following are guidelines for the geotechnical report:

- Identification of previous geotechnical work for the storage facility site and the key observations and conclusions from the previous work.
- A detailed description of subsurface soils and groundwater conditions.
- Identification and descriptions of known geologic hazards, including seismic, steep slopes and landslides, erosion, and contaminated soils hazards.
- Identification of locations for additional field explorations/borings, if needed.
- Conclusions and recommendations for design, including geologic hazards, seismic criteria (e.g., probabilities of peak ground acceleration), excavation and shoring, dewatering, foundation and backfill requirements, erosion and sedimentation control measures, and hazardous materials.

5.9.2.2 Structural Materials

A. Concrete Reservoirs

Three primary issues for concrete storage reservoirs must be addressed in design:

1. Corrosion of exposed reinforcing steel and corrosion caused by use of dissimilar metals, such as stainless-steel ladders adjacent to mild steel, either coated or embedded.

2. Foundation failure due to settlement or leaks causing undermining of the foundation.
3. Special considerations for how formwork is removed and concrete patched where planned holes/gaps are filled. SPU has numerous reservoirs with major issues caused by poor patching and removal of formwork.

The alkalinity and pH of cement materials can cause deep cracking on the interior of the facility and may expose the reinforcing steel to air and moisture, resulting in corrosion. As reinforcing steel corrodes, the integrity of the structure will weaken and eventually fail if not repaired.

Cracking in walls, roofs, and floors, failed expansion joints, and failed water stops are also common concerns with concrete reservoirs that should be addressed in design.

The following AWWA standards are typically required for design of concrete reservoirs:

- D110 – Wire- and Strand-Wound, Circular, Prestressed Concrete Water Tanks
- D115 – Tendon-Prestressed Concrete Water Tanks

B. Steel Tanks

The structural integrity of steel storage tanks is primarily affected by corrosion. Corrosion can attack specific portions of the tank and cause significant structural problems.

For steel tanks, unless otherwise directed, the following AWWA standards must be applied:

- D100 – Welded Carbon Steel Tanks for Water Storage

5.9.2.3 Coatings

For steel tanks, unless otherwise directed, the following AWWA standards must be applied:

- D102 – Coating Steel Water Storage Tanks

5.9.2.4 Liners

For liners and floating covers in contact with potable water, unless otherwise directed, the following AWWA standards must be applied:

- D130 – Geomembrane Materials for Potable Water Applications

5.9.2.5 Corrosion Control Systems

Corrosion control systems for steel tanks typically implement the following AWWA standards:

- D104 – Automatically Controlled, Impressed-Current Cathodic Protection for the Interior Submerged Surfaces of Steel Water Storage Tanks

Note: As of June 2015, SPU only has impressed current cathodic protection on the Trenton Stand Pipes and a sacrificial cathodic protection system on the Foy Stand Pipe. On well coated tanks, sacrificial cathodic protection systems are preferable. The design engineer should consult with a corrosion control specialist and evaluate the following:

- Conditions above and below the water level
- Fasteners and appurtenances located within the tank

Surfaces exposed to fluctuating water levels and the undersides of roofs are particularly at risk, yet they receive little benefit from cathodic protection. Proper coating systems are critical for these surfaces. Do not use dissimilar materials inside the tank (e.g., steel structure and stainless-steel ladders).

Seal weld all adjacent metal to avoid corrosion between the plates (see Figure 5-22). If this is not done, corrosion will form between the plates, and there will be no access for surface preparation or coatings in the future.

Figure 5-23
Seal Welds

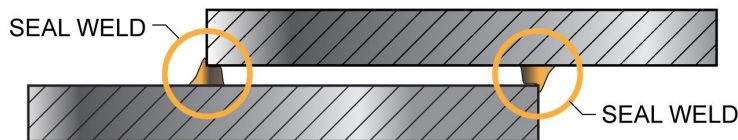

For more detail on corrosion control systems, see [DSG Chapter 6, Cathodic Protection](#).

5.9.2.6 Demolition

Demolition of other structures or buried utilities adjacent to or below a water storage facility's foundation or footings requires careful consideration to avoid damaging the foundation, footings, or yard piping associated with the facility. Before design of demolition, geotechnical and structural analyses should be done to determine potential impacts of the proposed demolition to establish a BOD for their protection. For information on demolition permit requirements, see [DSG Chapter 2, Design for Permitting and Environmental Review](#).

5.9.2.7 Configuration and Control for Service Reliability

The configuration and control for service reliability should consider the number of cells and flow control.

A. Number of Cells

To the extent practicable, new or refurbished facilities should have two or more cells to provide for greater reliability/redundancy.

If it is determined that a single cell meets the project requirements, it should be a dual outlet system. The lower outlet typically uses an earthquake/seismic valve.

B. Flow Control

The following are the minimum flow control requirements for storage facilities:

- Isolation valves on inlet and outlet lines that can be controlled locally and via SCADA.
- Piping and valves to provide for the bypass and drainage of the storage cell.

5.9.3 Hydraulic Mixing for Water Age and Water Quality Control

To prevent hydraulic dead zones and excessive water ages within a storage tank or reservoir, provide a means for complete hydraulic mixing throughout the entire volume of the storage cell. The configuration and sizes of inlet and outlet pipes to the cell have a direct impact on the degree of hydraulic mixing achievable.

Each storage cell should have a volume in which water age (hydraulic detention time) is not more than five days at projected average water demands when the reservoir operates at full capacity. The goal is to keep total water age through the reservoir to no more than a 5-to-7-day range.

The Water Research Foundation publication, *Maintaining Water Quality in Finished Water Storage Facilities*, describes design considerations and features for controlling water quality in storage facilities.

5.9.3.1 Inlet and Outlet Pipes

Generally, a separation of the inlet and outlet points within a storage cell will enhance mixing and help avoid water quality problems associated with dead zones and short-circuiting. For ground tanks, this is done by locating the inlet discharge near the perimeter of the cell with an upward bend. The tank outlets are then placed into the center of the tank floor. In elevated tanks, inlet and outlet points are separated one of two ways:

- Bring separate inlet and outlet lines up through the tank.
- Split the line in the riser and use check valves to introduce water into the center of the tank near the top of the water column. In this option, the outlet pipes are placed at the tank perimeter with a vertical separation to the inlet elevation of not less than about $\frac{1}{2}$ the total cell height.

Proprietary pipe and valve systems for storage facilities can be specifically designed based on the momentum mixing principle. The Red Valve Company system has gained widespread use.

For smaller tanks (less than 0.5 million gallons), the inlet and outlet may not need to be separated. Smaller tanks have smaller volumes, which allow adequate momentum for mixing.

A. Inlet Pipe

The inlet pipe should be as small as practicable to maximize inlet velocity to provide for adequate momentum mixing throughout the storage cell to preclude hydraulic short-circuiting. Reductions of inlet diameter have also been retrofitted on existing SPU tanks during tank renovation by using a reducer on the discharge end of the inlet pipe.

B. Outlet Pipe

In single-cell ground level reservoirs, each storage cell should have two outlet pipes, one near the mid-level and the other near the bottom of the cell. Both outlets should have isolation valves. The mid-level and lower outlets remain open for normal operation. The lower outlet should have a seismic valve that closes automatically during an earthquake to prevent the cell from draining past the mid-level.

In double-cell ground level reservoirs, outlets should have seismic outlet valves that close automatically during an earthquake to prevent the cell from draining. Typically, one seismic valve will be disabled to make half of the stored volume available for firefighting purposes, while the other seismic valve will close to retain water for future use.

5.9.3.2 Sizing Inlet Nozzles for Momentum Mixing

The inlet pipe and nozzle to each reservoir cell should be sized to provide a velocity of the entering water to enable complete hydraulic mixing throughout the entire cell. Typical time to mix the cell should be four to six hours at the designed inlet flow rate for lower-demand periods.

5.9.3.3 Mechanical Mixing Systems

If adequate momentum mixing cannot be achieved using inlet jet velocity (due to flow rates in relation to reservoir cell size), consider enhancing using a mechanical method. The following are three mechanical mixing methods:

- **Pumped recirculation.** This system features a pumped recirculation loop with the suction line from the reservoir and the discharge line entering the reservoir through a single port or multiple ports.
- **Mechanical mixers within the reservoir.** If higher-pressure water is available, consider a **gravity hydraulic mixing system** that pipes the higher-pressure water to the tank and mixes through a series of nozzles attached to a riser pipe in the tank.

A. Recirculation

- Recirculation systems should be designed for continuous pumping. A general estimate for recirculation pump sizing is 1 hp per million gallons of storage volume.
- Provide at least two pumps for full redundancy.
- To the extent practicable, select pump sizes and types that are compatible with recirculation pumps at other reservoirs so that pumps are interchangeable and can be used as replacements or spares.
- The recirculation grid size depends on the size of the storage cell, but the recirculation grid should be designed to ensure that it adequately covers all areas of the cell. Pipe sizes for these grids are typically 4 to 6 inches in diameter.
- Orifice sizes and spacing are designed to achieve the velocities necessary for adequate localized momentum mixing. Typically, the range of velocity needed is 8 to 10 fps at the orifice discharge.
- Provide an easily accessible sample collection point on the recirculation piping.
- Provide an easily accessible chemical injection point on the recirculation piping.

5.9.4 Water Level and Flow Measurement

- Each storage cell must have provisions for online measurement and recording of water levels between the top of the outlet sump and overflow levels.
- Provide a totalizing meter on the outlet side to accurately measure demand from the reservoir.
- Provide a totalizing meter on the inlet side to accurately measure flow into the reservoir.
- Provide positive online indication of overflow.

5.9.5 Mechanical Appurtenances and Equipment

This section describes mechanical appurtenances and equipment for water storage facilities.

5.9.5.1 Location

To the extent practicable, mechanical appurtenances such as valves, pumps, and controls should be located in clusters. If applicable, they should be located in mechanical rooms or vaults for ease of maintenance and security.

5.9.5.2 Penetrations to Storage Cells

Penetrations for pipes, hatches, vents, and sensors into storage cells require special design considerations to preclude the intrusion of contaminants. The following are general considerations for mechanical appurtenances and equipment that penetrate storage cells:

- Materials and coatings of appurtenances should provide for high resistance to corrosion.
- Open ends of vents on ground level reservoirs should be oriented downward and provided with 24-mesh, corrosion resistant screens. Duckbill check valves may be used on overflow piping or vents where there is potential for a large volume discharge.
- Open ends of vents on elevated tanks and standpipes must open downward, and either be fitted with 4-mesh screen, or with a finer mesh screen in combination with an automatically resetting pressure-vacuum relief mechanism. Duckbill check valves may be used on overflow piping or vents where there is potential for a large volume discharge.
- Wall and roof penetrations are welded onto steel tanks and are equipped with seep rings on concrete reservoirs.
- Valve stem penetrations should be sealed to prevent entry of contaminants.
- Materials used at penetrations should be selected to avoid creating galvanic currents between dissimilar metals.

5.9.5.3 Vents

- Vents should be located at least 2 ft above finished grade or the 100-year flood elevation, whichever is greater.
- Design vent areas to allow for adequate air intake assuming restricted flow through dirty bug screens during rapid drawdown of the water level such that the maximum pressure drop within the storage cell does not impose structural stresses. The acceptable maximum pressure drop is a function of structural materials and configuration of the storage cell. Acceptable maximum pressure drop should be established by a design engineer or manufacturer.

5.9.5.4 Overflows

The following are SPU standards for overflow pipes:

- Overflow pipes must be sized to accept flow rates equal or greater to the maximum inflow rate to the storage cell.
- Overflow pipes must terminate at an air gap (see DSG sections 5.6.5.3 and 5.6.5.4), and should be easily visible to O&M staff. **Do not put valves on the overflow pipe.**
- The surface below the air gap must slope away from the storage cell and direct the flow to a sump or catch basin from which the flow is conveyed to the designated discharge point.

The following are guidelines for overflow pipes:

- If the overflow water enters a sewer, check sewer pipe hydraulics for any constraints to accepting the design overflow rate.
- If the overflow water can enter a natural stream or pond directly from the discharge point, a passive dechlorination system should be installed. For example, a passive dechlorination system is a catch basin within which bags of a dechlorination chemical (ascorbic acid or sodium thiosulfate) are placed. The overflow water is passed through the dechlorination structure before discharge to the receiving water body.
- In addition to a screen, consider installing a flap gate at the end of the overflow pipe to prevent animal access. A duckbill valve may be used in place of a screen and flap gate to prevent animal access. The duckbill should be recessed within a pipe to discourage vandalism.

Note: Overflows usually go to a reservoir's dedicated storm drain line. This line must also be capable of the flow rate. The receiving water body must likewise be able to receive this flow rate.

5.9.5.5 Connections

Connections between the storage cell structure and pipes external to the structure (either exposed or buried pipes) should allow for longitudinal expansion and lateral movement that occurs during earthquakes and through long-term differential settlement. Pipes located under ground-level reservoirs should be encased in reinforced concrete to minimize future maintenance.

5.9.5.6 Hatches

The following are SPU standards for water storage hatches:

- All access hatches not bolted to the main structure must be lockable and provide intrusion switches linked to the SCADA system.
- Hatch lids covering openings to water storage facilities must be designed to prevent drainage runoff from entering interior of the hatch and/or accumulating next to the hatch area. This also provides protection from ice damage. For hatches with raised curbs or frames, the lid should overlap the curb/frame.

The following are guidelines for hatches:

- For accessible ground-level hatches to concrete reservoirs, the hatch should be designed either to lock or to accommodate a 600-lb block or lid on top.
- Hatches manufactured by LW Products or Bilco have typically met SPU requirements.
- Hatches installed in graveled areas should be raised above grade to prevent gravel from becoming lodged and jammed between the frame and the lid or becoming lodged in the locks.

5.9.5.7 Access Ladders and Catwalks

The following are guidelines for access ladders and catwalks:

- Fall protection equipment must be provided.
- Select material and coatings to provide for high resistance to corrosion and graffiti.
- For above grade facilities, entries to ladders or catwalks should be elevated at least 10 ft above grade and have a lockable gate or door. The gate or door should be designed to allow for safe access from a cherry picker or similar.
- For internal stairs or catwalks over finished water, the steps should be solid plates with raised edges to help prevent dirt from entering the water.

5.9.5.8 Mechanical Rooms and Vaults

The following are guidelines for mechanical rooms and vaults:

- Provide for proper interior drainage within the valve chamber, including floors sloped to drains and/or sumps.
- Provide for perimeter drainage.
- Top of chamber should be at least 1 ft above finished grade.
- For access hatches and vents to valve chambers, see DSG section 5.9.5.6.

5.9.5.9 Storage Cell Drainage Equipment and Features

The following are guidelines for storage cell drainage equipment and features:

- Cell drainpipes must not be cross-connected to a storm or sanitary sewer line. They need an air gap or backflow prevention device.
- The floor of a storage cell should be sloped to enable drainage to a single sump.
- If feasible, the sump should have a pipe that drains via gravity to the designated cell drain point with an air gap. The sump should be sized to accommodate a portable sump pump, even if there is no drainpipe.
- Size drainpipes to accept flow rates such that the cell can be drained in the minimum amount of time without exceeding the capacity of the discharge point.
- Control valves for drainpipes should be easily accessible. Wherever possible, the location of drain valves should be within the valve chamber for the storage facility.
- Provide a removable mud/silt stop at the upper edge of the sump, or locate to prevent discharge of sediments into the outlet and drainpipes.

A. Roof Drains

The following are SPU standards for roof drains:

- Roofs must be watertight and sloped for drainage.

- Roof drains must be connected to a permitted drainage system.
- Roof downspouts must be external and not mounted within the storage cell. None of the drain system should be within the storage cell.
- Domestic water and stormwater must not co-mingle.
- SPU requires certain Green Stormwater Infrastructure (GSI) elements be incorporated into structural design of new projects. For more information on GSI, see section 8.7.10 of [DSG Chapter 8, Drainage and Wastewater Infrastructure](#).

5.9.6 Multi-Use Facilities

Where a storage facility is to be integrated with other recreational uses (e.g., tennis or basketball courts), grass-covered recreational areas, or parking lots special consideration should be given to physical and sanitary security issues. Storage facility design should address the following:

- Locate hatches to storage cells and valve chambers that are physically separate and secure from public areas, but visible from adjacent streets to enable observation by law enforcement or security personnel.
- Provide physical security to intrusion for hatches, tank ladders and doors to valve chambers or other enclosures.
- Provide appropriate signs that clearly indicate areas that are for authorized personnel only.
- Provide lighting fixtures and features that give the necessary level of lighting for security without negative impacts to adjacent public areas. Lighting fixtures should be designed so that the wiring and/or bulbs are not exposed or easily accessed to preclude inadvertent damage or vandalism.

Refer to the current agreement between Seattle Parks and Recreation and SPU ([Appendix 5F](#)) for specific items associated with multi-use reservoir sites.

5.9.7 Landscaping and Weed/Pest Control

For detailed information on landscaping and weed and pest control, see [DSG Chapter 4, General Design Considerations](#).

5.9.8 Access and Security

5.9.8.1 General

The following are general considerations:

- Include SPU Security Plan requirements for general security and security design requirements for water facilities.
- If the storage facility site is not open for public use, provide a means of controlled access around the entire perimeter. If the site will be open for public use, provide a means of controlled perimeter access around the hatches, vents, and vaults.

- Provide security alarms at access doors or hatches tied into the SCADA system.
- To the extent practicable, do not allow site features where unauthorized persons or materials can be easily concealed, such as structures, trees, or vegetation.

5.9.8.2 Personnel Access and Safety

A. Access

The design of access features for storage facilities should address the following:

- Vehicular access to hatches and ladders is required and should be sized to accommodate the size of the vehicles normally used in maintenance or inspection of the facility.
- Ladders, stairways, and catwalks designed to conform to Occupational Safety and Health Administration (OSHA) requirements.
- Hatches placed to facilitate ease of maintenance and cleaning.
- Hatches sized to accommodate access for personnel with tools, inspection divers, and remotely operated vehicle (ROV) inspection/cleaning equipment. For larger facilities, this requirement typically results in one or more large equipment hatches, through which field equipment can be lowered, and one or more personnel access hatches.
- Provide ladders or stairways inside of storage cells.
- Ladders should be caged and have climbing or fall protection.

B. Egress and Emergency Escape

The following are egress and emergency escape features:

- Provide internal and external restraint support/safety equipment.
- Ensure unobstructed clearances to access/egress points.
- Provide any other features necessary to meet requirements associated with confined-space entries.

5.9.8.3 Operations & Maintenance

A. Lighting

- Permanent lighting fixtures should be provided to light hatch doors into storage cells and vaults and to provide visibility to the local work area perimeter.
- Permanent lighting fixtures should be provided to provide a minimum acceptable level of lighting within storage cells and vaults for routine inspections and maintenance.
- Power outlets should be easily accessible to all hatches for the operation of temporary lights within storage cells and vaults.
- Convenience outlets should be within 6 ft of all mechanical equipment.

B. Ventilation

Hatches to storage cells and vaults should be located to accommodate temporary ventilation equipment, including points for the introduction and exhaust of ventilation air.

To the extent practicable, power outlets should be easily accessible to all hatches to facilitate the operation of temporary ventilation equipment.

Permanent ventilation system should be capable of eight exchanges per hour at all times.

C. Communication System

Determine the methods of communication to be used by personnel during facility maintenance (e.g., radio, wire intercom) and provide appropriate equipment or appurtenances for their use.

At a minimum, provisions for antenna mounts are one mount for every two communications lines. If there is only one communications line, then one mount is needed. Locations of the mounts are site specific. Roundup spare conduits for future installation should be considered.

5.9.9 Water Quality Monitoring/Sampling

Water quality monitoring and sampling locations must be provided for in the design of water storage facilities. Water quality is tested in storage facilities prior to putting them into service and on an ongoing basis as part of monitoring and maintaining water quality in the distribution system. In addition, the design must consider the means for disinfecting the facility prior to putting it into service. Given the infrequency of new facility design, SPU does not have specific, written design requirements that cover all types of storage facilities. SPU water quality and Operations staff must be involved in determining the specific needs of the facility being designed. Sampling and monitoring requirements for the specific facility need to be established and documented before final design. See also DSG section 5.9.10 Disinfection and Dechlorination.

5.9.9.1 Continuous Monitoring

Some facilities will require infrastructure to support continuous automated monitoring for chlorine and possibly pH and temperature. At a minimum, the following items will be required:

- Sample taps or inlets
- Sample line piping
- Power and telemetry for analyzer(s)
- Facility drain
- Cabinetry or housing

Multiple sample points are used and will include inlet and outlet of each storage cell as well as points within the sample cell.

5.9.9.2 Sampling for Manual Monitoring

All facilities must have manual sample points that draw from locations within the storage facility and its piping. Multiple sample points are used because of the potential for variations in water quality spatially. Locations to be considered include storage cell inlet and outlet, multiple depths, and horizontal spacing. Facility size and configuration as well as use of a mixing or dispersal system are factors to consider in determining sampling points. Tall storage facilities will generally need sampling points at multiple depths. Typically, standpipes and elevated tanks have sampling points at high, middle, and low elevations. If the extent of the horizontal footprint of the storage facility is large relative to the vertical height, one or two additional locations may be added across the cell (in addition to the center sampling point). Additional samplings points may also be needed to facilitate disinfection and testing when a facility is first put into service and following inspection or cleaning.

Sample ports should be easily accessible without the need to open hatches to the storage cell. Where practicable, the pipes from all sample ports should terminate at a single sampling station within a lockable cabinet at or near ground level outside the storage cell or within the valve chamber.

5.9.9.3 Storage Facility Disinfection

In addition to sampling ports, storage tanks and reservoirs must be designed with means for disinfection of the facility according to AWWA standards. There are different methods for disinfecting storage facilities (e.g., spray method and fill method). The preferred method needs to be determined for the specific facility configuration and documented prior to design. When the spray method is to be used, a means of personnel access and a source of water must be provided. Where sodium hypochlorite (bleach) is to be added for disinfection, the design needs to include a port where the bleach can be added and adequately mixed for the disinfection method used.

5.9.10 Disinfection and Dechlorination

SPU uses portable ascorbic acid dechlorination units for all dechlorination operations. The drain-down pipe from each storage cell must have a liquid chemical injection station for direct injection of ascorbic acid.

5.9.10.1 Booster Disinfection

Historically, SPU water storage facilities have received booster disinfection (chlorination). Booster chlorination may need to be considered for some existing storage facility sites should chlorine residual maintenance become a problem or a potential problem. Booster chlorination should be incorporated for new storage facilities located near the periphery of the distribution system where water demands may be initially low.

The following are major design considerations for booster chlorination at storage facilities:

- Footprint space for the chlorination storage and feed system facility.
- Access and security for the chlorination facility.
- Injection point for the chlorine.
- Post-treatment chlorine residual monitoring equipment and sampling points.
- Point of diversion of potable water for the chlorine feed system.
- Type of chlorination system: liquid commercial strength (12.5%) hypochlorite or on-site generation of hypochlorite. Gaseous chlorination systems must not be used.

5.9.10.2 Emergency Disinfection

Regardless of whether provisions are installed for booster chlorination, provide for facilities to apply emergency chlorination to each storage cell, to include the following:

- Hatches on top of each storage cell that can be used to introduce chlorine.
- Sample withdrawal points from within the storage cell and on the outlet of the cell to measure chlorine residual.
- Minimum of two valves between the storage cell and the distribution system that can be closed during disinfection.

5.9.11 Removal from Service

The following are key design features for the isolation and removal from service:

- Isolation valves on inlet and outlet lines.
- Piping and valves to provide for bypass of the storage cell.

5.9.11.1 Drain Features

Provide inlet isolation valve, reservoir drain valve, and a drain line to the discharge point. Drain valve must be capable of being throttled, as necessary. Locate the drain valve together with the other cell ancillary equipment in a lockable chamber. Drain should be capable of injecting a de-chlorination chemical with suitable contact time to fully mix if the discharge point is a receiving water body. To the extent practicable, the discharge point for drain water should be the same point used for overflow water discharge.

5.9.11.2 Drain Discharge Points

A. Sewers

Whenever possible, the point of discharge should be a sanitary or combined sewer because dechlorination of the drain water is not required. If neither a sanitary nor combined sewer is available, a storm sewer may be used, but dechlorination is required.

The maximum allowable drain water discharge rate to sewers should be based on the following:

- The hydraulics and sizes of the receiving sewer mains must be checked for any constraints and the maximum allowable dry-weather sewer capacity established.
- The acceptable minimum rate of discharge that meets operational requirements. If the operational minimum exceeds the maximum allowable dry-weather sewer capacity, the local sewer system may need to be modified, such as increase main sizes, re-lay mains to steeper grades, and/or add mains.
- The discharge flow rate design criteria must clearly establish the operational limits for the design flows. For example, drain operations are limited to dry-weather conditions to preclude sewer surcharging or the drain rate will be limited during wet weather. This information should be stated in the design criteria for the project and must be discussed with the Drainage and Wastewater (DWW) staff engineers or other agency that owns and operates the sewer facility.

B. Open Water Bodies

The discharge of drain water to an open water body such as a lake, pond, stream, or salt water, should be avoided to the extent practicable and only if there are no sewers available or suitable for receiving the discharge. Provisions for dechlorination must be made with guidance from the SPU Water Quality Lab on a project-by-project basis. Some standard methods such as for hydrant testing are available but they are subject to change. To get the most current methods contact the SPU Water Quality Lab.

The rate of discharge to an open water body is highly case-specific. Discharge flow rates to streams will typically be the most limited to preclude scouring and sediment mobilization. It should be assumed that a permit will be necessary for stream discharges, such as a Hydraulic Project Approval (HPA) and/or a National Pollutant Discharge Elimination System (NPDES) Water Treatment Plant General Permit. Therefore, the permits required should be determined before design. The specific requirements of the permit are the basis for the maximum allowable design discharge rate.

For more detail on permits, see [DSG Chapter 2, Design for Permitting and Environmental Review.](#)

5.9.11.3 Washdown Equipment

□

- The source of water to hose bibs must be potable water from the distribution system.
- The washdown water piping system must be separated from the distribution system with an approved backflow prevention device.

The following are guidelines for washdown equipment:

- Provide hose bibs or washdown system connections at or near access hatches used for maintenance to each storage cell. Hoses may be permanently stored at or near a hose bib, depending on maintenance and security requirements. However, washdown hoses should never remain permanently attached to the bib to avoid the potential for cross connections. Bibs and hoses should have quick-disconnect fittings for ease of maintenance.
- For larger facilities, provide washdown hose connections in a pattern such that any part of the facility can be washed using a 100-ft-long hose.

5.9.12 Standby Power

Consideration should be given to the need for dedicated standby power. In some cases, standby power may be required for some types of projects/facilities for continuous operation. Alternatives to dedicated standby power may be considered by the reviewing authority with proper justification. At a minimum, a power receptacle to the switchgear is required for the connection of a portable generator. Powered equipment and controls critical for water storage facility operation should be capable of using standby power. For more details on standby power, see [DSG Chapter 9, Electrical Design](#).

5.10 SEISMIC DESIGN

The seismic provisions for new SPU water system infrastructure are presented in this section. Design standards for new water mains are presented in DSG section 5.10.1. Seismic requirements for other types of SPU water system facilities usually fall under auspices of the Seattle Building Code (SBC). The application of the SBC seismic requirements to SPU water system facilities is discussed in DSG section 5.10.2. Dams and facilities needed to assure safe dam operation should be designed in accordance with the appropriate regulations and methods as determined by SPU's Dam Safety Group.

5.10.1 Terms

Table 5-12 Water Main Criticality Terms

Water Main Criticality	Description
Primary Backbone Pipelines	Transmission pipelines that convey water from the Tolt Reservoir or Lake Youngs Treatment Plant to the terminal reservoirs.
Secondary Backbone Pipelines	Transmission pipelines that convey water from the terminal reservoirs to distribution reservoirs or large service areas. Because Lake Youngs can supply

Water Main Criticality	Description
	the Cedar system for approximately four weeks, the transmission pipelines from the Landsburg Diversion to Lake Young are defined as secondary backbone pipelines.
Critical Water Mains	Water mains that are needed to supply hospitals or other critical facilities that must remain operational after an earthquake. The water mains in a network that are needed to bring firefighting water to within 1500 feet to 2000 feet to most direct service area structures are also defined as critical mains.
Ordinary Mains	All water mains that are not classified as backbone or critical mains.

Table 5-13 Earthquake Hazard Exposure Terms

Earthquake Hazard Exposure	Description
Permanent Ground Displacement Susceptible Area	<p>Those areas that are:</p> <ol style="list-style-type: none"> 1. Identified by Palmer et al. (2004) as having a high- or moderate-to-high liquefaction susceptibility or peat area, or 2. Defined by the Seattle Department of Construction and Inspection to be a Known or Potential Slide Area, or a peat area or 3. Defined as a King County Landslide Hazard Area, or 4. Defined as a Washington Division of Geology and Earth Resources Landslide Area. <p>If a geotechnical investigation shows that permanent ground displacement is possible along the alignment even though the alignment is not within one of the identified permanent-ground-displacement-susceptible areas, then that pipeline must be considered to be in a permanent-ground displacement susceptible area. Alternatively, if a geotechnical investigation shows that the pipeline alignment is not susceptible to permanent ground displacement even though the alignment lies within a permanent ground displacement susceptible area, the pipeline may be designed as if it does not lie in a permanent-ground displacement susceptible area.</p>
Seattle Fault Zone	That area defined by Pratt et al. (2015) as adopted by Lettis Consultants International, Inc. (2016) as being in Zone A or Zone B.
SPU Intense Ground Shaking Region	The area within the SPU transmission and distribution region where the 2014 USGS 0.02 probability of exceedance in 50-year peak ground accelerations are greater than or equal to 0.6 g.

5.10.2 Seismic Design Standards for New Water Mains

5.10.2.1 Applicability

This standard applies to new water main construction, including new pipelines that are replacing existing pipelines. Existing water mains need not adhere to these standards unless they are rehabilitated or replaced.

5.10.2.2 Water Main Seismic Design Requirements

The level of analysis and performance required for water main design and construction must be in accordance with the water main criticality and earthquake hazard exposure as defined in Table 5-14. For any pipeline, if a site-specific analysis shows a lesser level of design than that stipulated by Table 5-14 is adequate, then that pipeline need only be designed in accordance with the design indicated by the site-specific analysis.

Table 5-14
Minimum Water Main Design & Construction Analysis & Performance Requirements

Water main Class/Criticality	Permanent Ground Displacement Area ¹	Seattle Fault Zone or SPU Intense Ground Shaking Region ¹	
		Performance Specification 2	All Other Areas
Ordinary	Performance Specification 1	Performance Specification 2	No seismic requirements
Critical Mains	Performance Specification 1	Performance Specification 1	Performance Specification 1
Secondary Backbone	Site-specific analysis	Performance Specification 1	Performance Specification 1
Primary Backbone	Site-specific analysis	Site-specific analysis	Site-specific analysis

Notes

¹ For those pipelines that lie in both a permanent ground displacement area and intense ground shaking region, the permanent ground displacement area requirements govern.

5.10.2.3 Performance Specification 1 Requirements

A. Pipe Material

I) Ductile Iron Segmented Pipelines

- Axial Elongation (at each joint): 1% Minimum Axial Elongation or Shortening.
- Axial Pullout Strength (of each joint): 17,100 pounds per inch of nominal diameter.
- Deflection (at each joint): 5 degrees of deflection per 20-ft segment. Prorate for shorter or longer segment lengths.

Pipe Diameter	3" – 16"	18" – 40"	44" – 60"	64" – 88"	96" – 104"
Deflection angle	8°	7°	5° 30'	4°	3° 30'

- Fitting joints must meet the axial pull out strength requirements but do not need to meet axial elongation and deflection requirements.
- Segmented pipeline systems that meet the Performance Specification 1 requirements include, but are not limited to:

- Kubota Genex Hazard Resilient ductile iron pipe (HRDIP)
- American Pipe Earthquake Joint Pipe

ERDIP should be installed per the manufacturer’s recommendations. Typically, ERDIP joints will be set in the neutral position (joints permit equal amounts of contraction and expansion, and joint can deflect equally in all directions). If seismic hazard characteristics warrant, the joints may be set in a nonneutral position. To accommodate alignment curvature requirements, the pipe joint may be deflected up to 50% of the design deflection limit if the alignment is on level ground. If the pipeline alignment is on sloped ground and the slope may displace in a direction that would cause the pipeline alignment’s radius of curvature to decrease (bend more), then the pipeline segment lengths should be shortened or ball joints should be provided so that the Performance Specification 1 joint deflection requirements are maintained in the direction of the expected slope movement.

ERDIP joints can extend and contract in the axial direction. Similar to ball joints, ERDIP joints can also deflect. Thrust blocking that is similar to the thrust blocking that is used for segmented pipelines with unrestrained joints should be provided. Thrust blocking must also be provided at fittings and hydrants where unbalanced hydraulic loads may occur.

Thrust collars should be used for valves in earthquake-resistant pipe alignments. The valves should be flanged and a flange by RJ adapter should be used to connect the valve to main.

2) Continuous Pipelines

- Welded steel pipe with butt-welded joints must meet the requirements of AWWA C200 and

$$\frac{D}{t} \leq 100$$

Where:

D = the pipe nominal diameter in inches

t = the pipe wall thickness in inches (minimum thickness = 0.25 inches)

- HDPE pipe must meet the requirements of MAB-3-2017, AWWA C906 and ASTM International (formerly American Society for Testing Materials) F2620. Joints must be butt-fused.

B. Pipe Bedding and Backfill

Pipe bedding and backfill should be as specified in Standard Plan 350 of City Standard Plans for Municipal Construction. The use of controlled density fill (CDF) or other backfill/bedding that could restrict pipe movement, alter seismic performance, or alter corrosion control measures is not permitted unless CDF is necessary due to site conditions, restraints, or third-party requirements and approved by the pipeline engineer. The bedding requirements are also waived for earthquake-resistant HDPE pipe that is installed by HDD.

C. Hydrants in Permanent Ground Displacement Areas

In permanent ground displacement areas, the design should allow for a minimum of 8 degrees of deflection and 2 inches of both expansion and contraction (4 inches minimum total) within 5 ft of the hydrant connection.

Examples of acceptable joint systems that meet these requirements include:

- One earthquake pipe joint
- One EBAA Iron Flex-Tend fitting at the hydrant tee

Hydrant pipe runs 30 feet or longer should use earthquake resistant pipe that meets the Performance Specification 1 requirements. Preference should be given to fitting joints that meet the Performance Specification 1 pull out strength requirements.

Hydrant connection details should be shown on the project plans.

D. Services in Permanent Ground Displacement Areas

For copper water services (2 inches or smaller), provide enough slack to provide a minimum of 6-inches of movement at the connection.

For services that are 4-inches in diameter and larger, see requirements for hydrants in permanent ground displacement areas.

E. Vaults in Permanent Ground Displacement Areas

In areas susceptible to permanent ground displacement, flexibility should be provided near the interfaces where ductile iron pipelines are connected to vaults. Provide a segment or fitting with joints that meet the Performance Specification 1 deflection and elongation requirements past where the valve is restrained by a thrust collar.

F. Connections to Existing Pipe

1) Between Distribution Mains and Transmission (Backbone) Pipelines in Permanent Ground Displacement Areas

- A minimum of 8 degrees of deflection in any direction and 2 inches of both expansion and contraction (4 inches minimum total) that meet the Performance Specification 1 should be provided in the distribution main within 5 ft of the connection point to the transmission pipeline.

2) To Existing Earthquake-Resistant Pipe

- If the existing pipe is already earthquake-resistant pipe that meets this standard, then the fitting/connection must also meet this standard.

3) For All Other Cases

- The connection/fitting to existing pipe does not need to meet this standard's earthquake requirements but must be restrained with thrust collars to lock connection in place.

5.10.2.4 Performance Specification 2 Requirements

The following pipelines are permitted in Performance Specification 2 areas:

- RJ ductile iron pipe that conforms to the City Standard Specifications and Plans. Additionally, for RJ ductile iron pipe that is being restrained only to address seismic concerns, Series 1100 MegaLug MJ restraints are acceptable.
- Welded steel pipe joint with either lap or butt welds. Use double-welded lap joints for pipe 24 inches or larger.
- HDPE pipe that meets the requirements of AWWA C906 and ASTM International F2620.
- RJ, AWWA C909 molecularly oriented polyvinyl chloride pipe (PVCO) if this material is approved for the project.

5.10.2.5 Site-Specific Analysis

The site-specific analysis must meet the following minimum requirements:

- Geotechnical hazards must be identified and evaluated along the pipe alignment.
 - Geotechnical hazards must be consistent with those hazards that would occur from 0.02 probability of exceedance in 50 years (2475 average return interval) ground motions.
 - Geotechnical hazards must include transient seismic wave propagation/ground shaking hazards and permanent ground displacement hazards.
- The pipeline must be designed and constructed to resist and accommodate the forces and ground motions/displacements along the alignment determined in Step 1. The following criteria must be met:
 - The pipeline must remain operable during and after the seismic event.
 - Inelastic behavior, possibly requiring eventual repair or replacement, is allowable providing the pipeline can remain operable until the post-earthquake emergency conditions have passed.
 - The larger of either the mean or medium values of the estimated geotechnical hazards (e.g., permanent ground displacement and peak ground velocity) must be used in the analysis.
 - A factor of safety equal to 1.0 may be used.

5.10.3 Repairs in Alignments That Require Earthquake-Resisting Pipe

5.10.3.1 Emergency Repairs

When emergency repairs are needed, the repair does not need to meet the seismic requirements described in this standard. If earthquake-resistant pipe and/or joints are available, repairs to existing earthquake-resistant pipe should be made with earthquake-resistant pipe, when feasible. For critical and backbone pipelines, if the

existing pipeline consists of earthquake-resistant pipeline and the repair is not made with earthquake-resistant pipe, the non-earthquake-resistant pipe repair should be replaced with earthquake-resistant pipe in accordance with the non-emergency repair requirements within three years of the emergency repair.

5.10.3.2 Non-Emergency Repairs: Two or Less 20-Ft Pipe Segments Repaired

If the existing pipe is not earthquake-resistant pipe, then the repair may be made without regards to the seismic requirements in this standard. Repair documentation should note that the repair does not meet the seismic requirements and the repaired sections should be replaced with earthquake-resistant pipe when the surrounding pipe is replaced by earthquake-resisting pipe.

If the existing pipe is earthquake-resistant pipe, the repaired pipe joints need to be strong enough to transfer the seismic forces to the remaining earthquake-resistant pipe (e.g., if the pipe is ductile iron pipe, the repair pipe joints and joints connecting to the existing earthquake-resistant pipe need to meet the Performance Specification 1 pull out strength requirements) but the repair pipe joints do not need to meet to the Performance Specification 1 extension/shortening and deflection requirements.

5.10.3.3 Non-Emergency Repair: More Than Two 20-Ft Pipe Segments Replaced

If the existing pipe is not earthquake-resistant pipe but the alignment is located in an area that requires earthquake-resistant pipe, the repair should be made with earthquake-resistant pipe, when feasible. If it is not practical to make the repair with earthquake-resistant pipe, then the repair should be replaced with earthquake-resistant pipe when the adjoining pipe is replaced with earthquake-resistant pipe.

If the existing pipe is earthquake-resistant pipe, then the repair should be made with earthquake-resistant pipe.

5.10.4 Seismic Design of Buildings, Tanks/Reservoirs. Other SPU Water System Structures and Nonstructural Elements

Seismic provisions for buildings, tanks, reservoirs, non-building structures and nonstructural elements are covered by the ASCE 7-22, Minimum Design Loads and Associated Criteria for Buildings and Other Structures, the Seattle Building Code (SBC) and the International Building Code (IBC).

The SBC is the minimum acceptable design level. There may be some instances when more stringent design requirements are appropriate. Outside City limits, King County Building Code Requirements must also be met. Because King County also adopts the IBC, the King County Building Code requirements are similar to the SBC. To allow designers the greatest flexibility in addressing seismic-resistant design, the DSG does not specify means and methods for satisfying seismic design requirements.

5.10.4.1 Building Occupancy Category

Seismic design requirements are a function of building occupancy/criticality. Facilities that must remain functional are classified as essential facilities by the IBC. SPU building and non-building structures should be classified as essential facilities, including:

- Tanks and reservoirs
- Pump stations and wells
- Support facilities (offices, warehouses, repair and maintenance)
- Pipeline Support Structures and Vaults

Office facilities are considered essential facilities because these offices are needed to house staff that is essential to operating the water utility. Essential facilities are defined as any facility needed to maintain water operations (supply) or for emergency response activities. Redundant facilities or facilities that are not essential to water system operation or emergency response activities do not need to be designed as essential facilities.

5.10.4.2 Nonstructural Elements

Nonstructural elements include building structure components (e.g., suspended ceilings and partition walls) and contents (e.g., motor control centers, communications equipment, storage lockers and building piping). Nonstructural element anchors, supports and braces should be designed in accordance with ASCE 7-22.

The component importance factor for nonstructural elements, I_p , should be set equal to 1.5. Additionally:

- Containers with hazardous substances or substances shall be anchored or restrained to prevent contents from being released. Two or more substances that may combine with other substances to create hazardous substances should be anchored or restrained to prevent the containers from releasing the stored contents and should be stored in separate areas.
- Suppliers of communication, mechanical and electrical equipment that must remain operable for an essential facility to function need to certify the equipment will remain operable in accordance with ASCE 7-22.
- Furniture and other components such as computers that are often moved need not be anchored providing that the unanchored elements:
 - Cannot fall and create an injury hazard or block egress routes
 - Are not needed to remain operable to maintain functionality of an essential facility

5.10.5 Commentary

The commentary is provided as guidance on how to satisfy the intent of the water pipeline seismic design standards.

5.10.5.1 Performance Philosophy

The intent of these standards is to eliminate most, but not all, water main damage. Earthquake-resistant pipe that meets Performance Specification 1 requirements has

withstood most earthquake-induced liquefaction, lateral spread, landslide, and settlement hazards. If earthquake-resistant pipe is used exclusively in permanent ground displacement susceptible areas, most but not all pipe damage would be prevented in these areas.

Because earthquake-resistant pipe is more expensive than non-earthquake-resistant pipe, non-earthquake-resistant pipe is permitted in areas that have not been identified to be susceptible to permanent ground displacement (approximately 80% of the direct service area). There would likely be some areas where ground displacements occurred in areas that had not been identified to be susceptible to ground displacement. Some pipe damage from transient wave propagation effects or unexpected permanent ground displacement would be expected in areas that had not been identified to be susceptible to permanent ground displacement. Although some pipe damage would occur throughout the system, this damage would not significantly disrupt the system and could be repaired relatively quickly.

In some instances, other departments or agencies such as the Seattle Department of Transportation may require SPU to replace or relocate water mains. If the projects are federally funded, Buy America rules may preclude using pipe that fully meets the Performance Specification 1 requirements. If a waiver to the Buy American requirements cannot be obtained and the project requires pipe replacement or relocation, Buy America-compliant pipe may need to be used that does not meet SPU standards. Buy America compliant pipe that does not meet this standard will reduce the SPU water system's seismic resilience so every effort should be made to employ a Buy America-compliant system that reduces the pipeline seismic reliability as little as possible.

More reliability is needed for critical and backbone pipelines. Meeting Performance Specification 1 pipe is the minimum requirement for all critical and backbone pipelines, regardless of the expected geotechnical conditions. Although damage to ordinary mains in isolated areas where unexpected ground displacement occurs may be considered acceptable, backbone pipeline or critical main loss of functionality is not considered acceptable. Using Performance Specification 1 for all critical and backbone pipelines makes pipeline survival more likely in areas where unexpected permanent ground displacement occurs.

In the future, SPU and other U.S. water utilities in regions with high seismicity may decide to use earthquake resistant pipe everywhere like some Japanese water utilities do. At the present, the use of earthquake resistant pipe is still in its infancy in the U.S. U.S. water utilities will need to become more comfortable with earthquake resistant pipe and learn the value of earthquake resistant pipe from earthquake experience before earthquake resistant pipe use becomes as common as it is in Japan.

5.10.5.2 Permanent Ground Displacement Areas

When permanent ground displacement maps are updated, the updated maps should be incorporated into this standard. If map updates include displacement bounds or estimates, then it may be appropriate to include a third performance specification category in between Performance Specification Categories 1 and 2 for pipeline systems such as lap welded steel, ERDIP that does not meet the ISO 16134 pull out strength requirements, PVC0 (molecularly oriented PVC), etc. that do not meet the Performance Category 1 requirements but still are capable of accommodating small to moderate permanent ground displacements.

5.10.5.3 Surface Rupture from Faulting

Surface rupture is possible during a large Seattle Fault or South Whidbey Island Fault event. The Seattle Fault zone is approximately 7 kilometers wide. Surface faulting could occur anywhere within this zone and could result in discrete surface displacements as large as three meters and distributed surface displacements of six meters (e.g., see Lettis 2016). Pipelines that are not specifically designed to resist these large displacements at the specific location that the displacement occurred would likely fail. Because there is so much uncertainty on where surface faulting may occur and the relatively low probability of surface faulting across any particular pipeline, it is not feasible to reliably design all pipelines against surface faulting in the Seattle or South Whidbey Island Fault zones. As earthquake-resistant pipe evolves and becomes less expensive, and the understanding of the crustal fault systems in the Puget Sound area increases, these standards will evolve. The current strategy considers that:

- For ordinary water mains, it is not feasible to design for fault ruptures across the entire Seattle Fault zone that would only occur across a small minority of pipelines. Because there may be intense ground shaking, at a minimum, Performance Specification 2 (Performance Specification 1 pipe in permanent ground displacement areas) pipe is mandated throughout the fault zone. As earthquake-resistant pipe evolves and becomes less expensive, in the future, this standard may be modified to require new ordinary mains to meet Performance Specification 1 requirements throughout the fault zone.
- For critical water mains, Performance-Specification 1 earthquake-resistant pipe must be used in all areas and the pipe would likely accommodate small surface faulting. It is not feasible to design for large surface fault displacement throughout the fault zone. There would be some failures if large surface ruptures occur, but it would be more cost-effective to have procedures and materials to quickly repair these breaks than to try to prevent them throughout the entire fault zone.
- Backbone pipelines are exposed to possible surface faulting in the Seattle and South Whidbey Island Fault zones. Ideally, fault resistant pipe will be used for primary backbone pipelines in the Seattle and South Whidbey Island Fault Zones. The InfraTerra Transmission Pipeline study indicated that large diameter ERDIP is the only currently available pipeline system that can accommodate expected Seattle and South Whidbey Island fault displacements. The ERDIP material cost is likely approximately twice as expensive as the material cost for welded steel pipe. There is uncertainty in the installation cost differential. Once the total cost differential is known, an informed decision can be made on whether butt-welded steel pipe (or possibly HDPE) that can handle small fault offsets should be used or if ERDIP that can handle the largest expected fault offsets should be used. When there are redundant backbone pipelines, only one of the redundant pipelines needs to be designed to accommodate the expected permanent ground displacements as long as failure of one pipeline will not affect the surviving pipeline. Emergency preparedness and response measures should be employed as necessary to more quickly repair any large diameter breaks that occur.

5.10.5.4 Site Specific Analysis

Site specific analysis is intended to include an assessment of the geotechnical hazards that may affect the pipeline alignment and the pipeline response to these geotechnical

hazards. The level of detail needed for the site-specific analysis should be commensurate with what is confidently known about the site characteristics and pipeline criticality. For example, if the pipeline alignment is located in an area without any apparent geotechnical hazards, the geotechnical engineer may be able to look at the site and available geotechnical data and then draw conclusions about the site without any detailed analyses. A pipeline engineer may also be able to specify the needed pipeline performance requirements/type without a detailed analysis. Alternately, both detailed geotechnical and pipeline analyses may be warranted if there is uncertainty in the geotechnical conditions and/or there may be large permanent ground displacements.

5.10.5.5 Buried Site Piping in Permanent Ground Displacement Areas

Using flexible piping when there are multiple bends in close proximity requires multiple thrust blocks and will only provide limited increased seismic resiliency. There will be a higher chance that there are significant differential displacements along longer straight pipe runs. Buy America compliant ERDIP is currently only available for 6-inch diameter and larger pipe. Consequently, a waiver will need to be obtained or Buy America-compliant HDPE will need to be substituted if 4-inch diameter ERDIP is specified on a Buy America project.

5.10.5.6 Hydrant Runs

Differential movement between the main and hydrant/hydrant piping can result in pipe failure. A segment with deflection and extension/shortening capability equivalent to the Performance Specification 1 criteria at both segment ends will permit the segment to pivot and permit some differential displacement of the main without breaking the hydrant run. Many of the fitting joints that are necessary for hydrant runs do not meet the pull-out strength requirements so it is currently not practical to require Performance Specification 1 pull out strength requirements in hydrant runs. If fittings that meet the Performance Specification 1 pull-out strength are not available, the available fitting joints with the strongest pull-out strength should be used. A thrust block is needed behind the hydrant foot to maintain the neutral position of the seismic joint. If the designer wishes to achieve a much higher degree of reliability, more specialized joints with extra telescoping and deflection capability should be considered than the criteria listed in this standard.

5.10.5.7 Services

Service line failure caused by differential movement between service lines and water mains is a common earthquake failure mechanism. Different water utilities around the world have suggested various measures to increase water service seismic resiliency.

HDPE services are commonly used in Japan. Taiwan has used stainless steel bellows. EBMUD is currently examining the development of a similar bellows system. HDPE services are more flexible and seismic resistant than copper, but copper is the current SPU standard and HDPE services are currently not permitted by SPU. Copper is somewhat flexible but not as seismic resistant as HDPE. Snaking the service near the main connection, using bellows or more flexible bedding at the service tap would likely increase service line resilience. In the future, the water industry may develop a more definitive standard for water services.

5.10.5.8 Pipeline Rehabilitation

There are many types of liners that are used to rehabilitate water mains and new liners are appearing on the market. On a case-by-case basis, a professional engineer will need to determine if the proposed liner meets this standard's seismic requirements.

5.10.6 References

InfraTerra. 2021. *Transmission Pipeline Seismic Study Seattle and South Whidbey Island Fault Crossings*.

ISO 16134:2020. *Earthquake-Resistant and Subsidence-Resistant Design of Ductile Iron Pipelines*. 2020.

Lettis Consultants International. 2016. Final Desktop review and Summary of the Seattle and South Whidbey Island Fault Zones for Seattle Public Utilities.

Municipal Advisory Board. *MAB Model Specifications for PE 4710 Buried Potable Water Service, Distribution and Transmission Pipes and Fittings*. MAB-3 2019.

Palmer, Stephen P., et. Al., 2004, Liquefaction Susceptibility and Site Class Maps of Washington State, By County, Washington Division of Geology and Earth Resources, Open File Report 2004- 20.

Pratt, T.L., Troost, K.G., Odum, J.K., and Stephenson, W.J. 2015. "Kinematics of Shallow Backthrusts in the Seattle Fault Zone." Washington State: Geosphere 11, No. 6, doi.10.1130/GES01179.1.

5.11 CONSTRUCTION

5.11.1 Requirements for Protecting Water Mains and Appurtenances

Any work on, connecting to, or near existing water mains should monitor and take steps to reduce construction impacts.

Projects that involve roadway construction or repaving, utilities construction, or deep excavations for structures often create conditions that can affect existing water mains (Table 5-14). Pipe with lead joints in older mains is susceptible to leaking and at high risk of failure if exposed to these activities.

The determination of whether vibration and settlement monitoring are required is subject to several variables discussed and requirements are not always the same for every construction project. Actual construction methods, equipment used, and the scope and duration of the construction activities may require stricter monitoring requirements or less strict as determined by SPU engineering staff.

**Table 5-15
Common Construction Conditions and Protection Measures for Water Mains**

Condition	Occurs When and Where	Pipe Protection Measure
Excessive loads	Haul routes for heavy construction equipment crossing over pipes Construction site entrances/exits Paving construction where excavations have reduced the cover over pipes	Steel plates in roadway Concrete pad Temporary cribbing Bridging Pipe relocation
Vibration and settlement	Dewatering of soils with higher water content around or adjacent to pipes Trench excavations adjacent to water pipes (e.g., excavations for sewer mains or duct banks that result in soil loss) Tunneling and other large open excavations Excavations for other utilities below water pipes Vibration from construction equipment (e.g., driven piles, sheet piles, or stone columns) Excessive loads Landslides	Temporary pipe supports Shoring of adjacent deeper trenches, as applicable Use drilling methods for the installation of shafts / columns instead of vibratory methods to the extent practicable Establish clear tolerances for acceptable pipe settlement and provide field monitoring for settlement
Impacts to thrust restraint	Excavations behind thrust blocks (loss of bearing surface behind the thrust block) Excavation and exposure of water pipes that are under pressure (loss of pipe surface friction component of thrust restraint)	Locate thrust blocks prior to construction Avoid disturbing thrust blocks to extent practicable Use temporary thrust blocks or collars or temporary tiebacks Avoid exposing pipes that are under pressure Avoid placement where future excavation may occur behind the thrust block. The clear area behind the thrust block should be determined with the consultation of a geotechnical engineer.
Contamination	Exposed water pipe joints within trench excavations that can fill w/ runoff or ground seepage water, particularly if main is depressurized Exposed water pipe joints within common trench excavations that have an active sewer main, particularly if water main is depressurized	Control runoff water to trench Sump pumps

5.11.1.1 Temporary Pipe Support Plan

Supporting existing utilities during construction can be difficult but is necessary to ensure no damage occurs to the existing water lines. Typically, the construction contractor is responsible for supporting all existing utilities throughout construction. **The Contractor must provide a support plan that is stamped by a Professional Engineer licensed in Washington State for review by SPU for approval.** SPU Engineering and Operations will review temporary supports in the field and notify the Contractor of deficiencies. SPU Water Operations staff does not direct repairs.

The following is a list of precautions contractors must take to avoid damage to water lines:

- Contractors must not use chains in direct contact with the pipe to move or support pipe materials because it may damage the pipe coating or introduce point loads that can over-stress pipe.
- Contractors must not rest the pipe on any sharp or pointed objects, including the bucket of any equipment, single point supports, or rods.
- Pipe must not be unsupported for a length longer than one stick of pipe or one joint.
- If the joints are not restrained, the Contractor must ensure crew safety by restraining the pipe from movement, which could separate the joints.
- Pipe must be supported in cradles or on wide support beams sufficiently spaced so the pipe does not sag and cause undue stress on the joints or pipe wall. This is especially important for cast iron pipe with lead joints.
- Do not expose more than one unrestrained joint at one time.
- Lead joint cast iron water mains must not be allowed to deflect while they are exposed. For this reason, settlement monitoring is required and the temporary pipe supports must be adjustable.

5.11.1.2 Settlement Monitoring

See [Appendix 5A - Settlement Monitoring Requirements for Cast Iron Watermains](#) and [Appendix 5B - Settlement Monitoring for Ductile Iron Watermains](#), respectively, for standard requirements for settlement monitoring of cast iron and ductile iron pipe.

Settlement monitoring requirements may be relaxed by SPU engineering staff if:

- The soil is firm, structurally sound and without water present.
- The water main bedding is not uncovered.
- The excavation exposes less than 18 ft of water main and only one joint maximum. This lowers the risk to the water main, and therefore the monitoring can be done by the SPU Inspector and/or Geotechnical Engineer on-site during the work. For example, crossings might fall under this category. If more than 18 ft of water main or more than one joint is exposed, the construction should be stopped until the water main can be temporarily supported within the excavation. See DSG section 0 Temporary Supports during Construction.
- Parallel trenches are shallow (above the zone of influence).
- A non-vibratory roller compaction method is used.

5.11.1.3 Vibration Monitoring

All construction projects, whether SPU-originated or not, are subject to the following vibration and settlement monitoring criteria:

- Construction activities greater than 20-ft from water main centerline generally do not require either vibration monitoring (VM) or settlement monitoring (SM). However, if, in the opinion of the resident engineer, project activities appear to be producing significant vibrations at the water main location, the Contractor may be required to monitor for vibration. If the project specifications do not provide a bid item for this

monitoring, a change order should be anticipated and the benefits of monitoring should be weighed against the additional cost of either monitoring or proactively replacing the pipe with ductile iron without the monitoring.

- Construction activities within 5 ft of the water main centerline should require VM at a minimum (continuously monitored by equipment).

When vibration monitoring is required, SPU will perform a pre- and post-construction acoustic leak survey of the existing water lines near the construction activities. If damage or leaking increases and the cause is determined to be the construction activities, the resident engineer will send a written request to the Contractor to restore damaged or destroyed property to its original condition. **The Contractor, not the owner or City, must pay for the repair or replacement of the pipe according to City Standard Specifications.**

Vibration monitoring requirements may be relaxed by SPU engineering staff if:

- There is no heavy equipment work (e.g., no concrete breaking, no vibratory roller).
- Saw-cut concrete will be pulled away from the water main location by 20 ft or more prior to being broken into pieces.

5.1.1.2 Removal and Abandonment of Existing Water Mains and Appurtenances

The following are SPU standards for removal and abandonment of existing water mains and appurtenances:

- Where required for water main projects, removal of existing water mains and appurtenances must meet the requirements of Standard Specifications section 2-02.3(7)B.
- All ends of abandoned water mains smaller than 12 inches in diameter must be plugged. Pipes 12 inches or larger in diameter must be abandoned and filled in accordance with Standard Specifications section 2-02.3(5) unless the pipe is to be left in place to be re-purposed for another use such as a utility casing. If Pipe is to be re-purposed, all open ends must be plugged with at least 12 inches of concrete.
- Water pipes designated on project drawings to be abandoned and filled must be filled with pumpable, flowable cement slurry that completely fills the pipe (Standard Specifications section 9-05.15).

After the record drawings (as-builts) have been incorporated into GIS, the engineer should check that the abandoned pipe is properly shown.

5.1.1.2.1 Considerations for Disposal of Hazardous Materials

The design and specifications of projects that remove or abandon water facilities must identify pipes that are known to have or may have hazardous materials. The Contractor needs this information to calculate the costs for special handling and disposal. The most commonly found hazardous materials in SPU's water system and considerations for their mitigation or removal are described in Table 5-15.

**Table 5-16
Hazardous Materials associated with SPU Water System**

Material	Prevalence in System	Mitigation/Removal
Asbestos Cement Pipe	Commonly used in water mains installed in 1940s and 50s. Uncommon now.	Avoid removal and abandon in-place where possible. <u>If removal is necessary, containment and air filtration requirements must follow OSHA and WISHA.</u>
Lead Joints	Almost all joints in older cast iron pipe have lead seals. Most of SPU's distribution system is cast iron w/ lead joints and can be expected to have decades of useful service if not physically disturbed.	Recycled by crews for other crew work.
Coal Tar-Lined and Coated Steel Pipe	SPU has coal tar coatings and or linings in the Cedar River Pipeline System as well as a few other steel pipes.	If removed, dispose to a licensed hazardous waste landfill. <u>Working and handling of coal tar materials must follow OSHA and WISHA standards.</u>

5.11.3 Construction, Startup and Acceptance Procedures

The design and specifications for construction activities related to transmission and distribution water mains should address the potential impacts of construction and repair activities on the hydraulic performance and sanitary conditions of the water system. Such activities pose a risk of microbiological contamination of new and existing water mains. Appropriate designs with clear specifications are major elements to achieving hydraulic performance requirements and sanitary conditions after construction or repair of water mains.

See the following Standard Specifications for construction (installation), startup, and acceptance of new and repaired water mains and appurtenances:

- Section 7-11: Pipe Installation for Water Mains
- Section 7-12: Valves for Water Mains
- Section 7-14: Hydrants

For further information on design and operational practices to prevent contamination of water mains, see the Water Foundation publication, *Practices to Prevent Microbiological Contamination of Water Mains*.

5.11.3.1 Shutdown of Water Mains

Shutdown and isolation of new and existing water mains should be addressed as part of design.

There are three major considerations for the shutdown and isolation of mains:

- Provide adequate numbers of valves for the isolation of the new or repaired mains to minimize impacts to water service in the distribution grid.
- Work with SPU Water Operations to provide a means to depressurize and dewater the main for a shutdown.
- Consideration of which customers will be out of water, and for how long. For customer impacts and service disruptions, see DSG section 5.11.4.

5.11.3.2 Construction and Repair Practices for Sanitary Control

The following section describes construction and repair practice for sanitary control.

A. Pre-Installation Materials Storage and Handling

Proper handling and storage practices (Standard Specifications section 7-11.3(2)) are key elements for achieving sanitary conditions in water mains.

SPU requires a pre-installation taste and odor testing of water pipe (Standard Specifications section 7-11.2(2)) of non-approved pipe sources. Request a current list from the Water Quality Lab (206) 684-7834.

B. Pipe Installation and Repairs

Controlling water and soil from entering pipes is a critical factor for achieving sanitary conditions in water mains. See Standard Specifications for sanitary control practices for water main construction and repairs:

- Section 7-11.3(2)A: Handling of Pipe – General
- Section 7-11.3(5): Cleaning and Assembling Joints

5.11.3.3 Post-Construction or Repair Startup and Acceptance

A. Acceptance

After water main construction or repair, the following requirements must be met before SPU will accept the connection to the water system and place it into service:

- Facility functions meet design requirements and has structural and watertight integrity, as demonstrated by hydrostatic pressure testing
- Sanitary conditions are provided by flushing, disinfection, and verified by water quality testing

B. Hydrostatic Pressure Testing

Water mains and appurtenances, including extensions from existing water mains greater than 18 ft, hydrants, and hydrant runs must meet the requirements of Standard Specifications section 7-11.3(11).

C. Cleaning and Flushing

After a water main installation has passed the hydrostatic pressure tests, cleaning and flushing must be completed per the requirements of Standard Specifications section 7-11.3(12)B.

D. Disinfection

The following Standard Specifications address water main disinfection procedures:

- Section 7-11.3(12)C: Required Contact Time
- Section 7-11.3(12)D: Form of Applied Chlorine
- Section 7-11.3(12)E: Chlorine Dosage
- Section 7-11.3(12)F: Point of Application for Liquid Disinfection

- Section 7-11.3(12)G: Backflow Prevention Requirement
- Section 7-11.3(12)H: Rate of Application
- Section 7-11.3(12)I: Disinfection of Connections to Existing Water Systems

E. Water Quality Testing and Criteria

Flushing is performed per the requirements of [Standard Specifications section 7-11.3\(12\)J](#) following chlorine disinfection to remove the disinfection chemicals from the main and continues until the water discharging from the flushed pipe has the same (or close to the same) chlorine residual as the source of flushing water. After the flushing is complete, samples for bacteriological analysis must be taken per the requirements of [Standard Specifications section 7-11.3\(12\)A](#).

All samples must meet the bacteriological criteria. If any sample does not meet the criteria, the installation must be re-disinfected, re-flushed, and retested until acceptable bacteriological results are achieved as required by [Standard Specifications section 7-11.3\(12\)K](#).

Post-installation taste and odor testing may also be required as described in Standard Specifications section 7-11.2(3).

F. Dechlorination

Chlorinated water from the disinfection of water mains must be dechlorinated before discharge.

Depending on discharge location, water drained from pipelines during shutdown must also be dechlorinated.

Typically, SPU uses an ascorbic acid (vitamin C) injection system for dechlorination. The chlorine concentration acceptable for discharge may vary depending upon the type and point of discharge. Discharges to a combined sewer may have some chlorine residual. Discharged water that may enter the environment, either through direct discharge to the ground for infiltration or via a storm drain, should have zero chlorine residual. The design engineer should clearly establish the acceptable points of discharge and chlorine residual criteria in the contract specifications. On most projects, dechlorination of disinfection water is the Contractor's responsibility.

5.11.3.4 Connections to City Water Mains

Standard SPU policy is that all connections of new or repaired water mains to the SPU water system are made by SPU Water Operations. **See Standard Specifications section 7-11.3(9)A and Standard Plans 300a, 300b, and 300c.** This policy originates from a revocable agreement with DOH that delegates SPU's Water Quality Division to supervise connections to the SPU water system and to ensure that sanitary conditions are maintained during the connection. If SPU fails to meet its obligations to properly clean and disinfect the connection during assembly, DOH may resume its lawful place as the inspector on all connections. A DOH inspector observing all connections to SPU's water system would result in additional expenses and require a significant amount of additional coordination during the connection phase. In short, the revocable arrangement for SPU to perform water quality inspections streamlines SPU's ability to perform its work. SPU guards this privilege carefully.

There are rare occurrences when SPU allows a contractor to make connections to the water system. Such cases may involve extremely short connection durations together with technically complex or unusual connection configurations or special equipment or connections at multiple locations simultaneously. The combination of special expertise together with multiple construction teams requires a carefully coordinated approach to the connection(s). When unusual project requirements are evident, the SPU project management and design team should obtain assistance from the SPU Water Quality engineer, the Water LOB, and an Operations representative. This should occur very early in project planning to determine whether the project should require the Contractor to make the connection.

If the team determines that the Contractor should perform the connection, the contract documents must be written with special provisions or a contract agreement that describes the work and expectations required. Special provisions must be made for an SPU Water Quality inspector to be present on-site during the construction and have direct authority over the Contractor's work during the connection to ensure that all work is performed per DOH regulations. This may be unusual for some kinds of contracting, such as design-build, and must be clearly understood in the Design-Build contract, especially if working on a project for another agency. SPU crews must also be on-site during connection, to assist as requested and for operating all live system valves.

Before the Contractor-assembled connections are scheduled, the Contractor must furnish a detailed work plan, reviewed by the SPU Water Quality engineer and approved by SPU Water Quality and Operations. Especially important are the roles and responsibilities for the various work components and tests to be performed (such as weld radiographs) and durations of various critical work items (such as curing duration of the closure piece cement mortar lining), if applicable.

5.11.4 Temporary Thrust Restraint

Temporary thrust restraint is sometimes required during construction to restrain pipe thrust forces usually where the pipe has been cut and capped and a dead end is created. Temporary restraint comes in several different forms and is usually installed before other work so that the pipe can be cut, capped, and turned back on in a single outage. In smaller diameters, a precast concrete block (Ecology block) is usually placed in front of the cap to act as a thrust block. In larger diameters, a tieback system is usually used where steel rods connect the cap to an anchor (usually two precast concrete blocks) and sometimes piles. **On projects where the Contractor must furnish temporary restraint for situations not covered by Standard Plans 330 and 331, the contract drawings must show a typical restraint detail, without design specifics, that has clear instructions directing the Contractor to submit a design stamped by a licensed engineer to SPU for approval.**

5.11.5 Customer Impacts and Service Disruptions

The design engineer or project manager should coordinate with SPU's Operations staff to determine timelines associated with water main shutdowns. This service disruption information should be forwarded to SPU's Communications and Customer Service Branch to perform outreach to all customers and businesses affected by the service disruption.

5.11.5.1 Customer Impacts

All known or potential impacts to customers associated with construction or repair of water system facilities must be identified. Community notification requirements vary depending on the following:

- Length or size of the project area.
- Number of customer services impacted, including anticipated service disruptions.
- Number and type of streets and street intersections in the project area.
- Extent of work outside of public ROW, such as work within temporary or permanent easements.
- Access to project area, including points of access, types of construction vehicles/equipment, and frequency of construction vehicle trips.
- Length of time and schedule constraints of the project.
- Work hours (day, night, weekend) needed to meet the project schedule and/or minimize community impacts.
- Type of environmental impacts to the local community, including noise, dust, mud, and light.

5.11.5.2 Service Disruptions

Service disruptions (water outages) are the impact of most concern to customers. **Specific requirements for service disruptions must be established for each project.** These requirements can vary depending on type of work, construction constraints, and schedule. Typically, SPU attempts to keep the number of outages for each water service to a maximum of two. The nature of the work and the location of the project may impact SPU's ability to achieve that target for all services.

5.11.6 Emergency Pump Connections

In some emergencies, a connection between two nearby pipelines may be needed. If the pipelines operate in different pressure zones, then a pump may be needed between the two lines. If possible, use an existing interconnection. If no inter-connecting pipe structure is available, a nearby blowoff location or other existing outlet can be used and a pump can be installed between the two pipelines.

5.12 OPERATIONS AND MAINTENANCE

This section describes O&M elements common to all SPU water infrastructure. See the appropriate sections of this chapter for O&M design issues specific to the infrastructure under design consideration.

5.12.1 Water Easements

An easement gives SPU specific property rights on land that it does not own. These property rights may be temporary or permanent. Permanent rights typically include the right to restrict activities or improvements by the landowner, and gives SPU the right to install, operate,

maintain, replace, and have access to SPU utility infrastructure, such as pipes, fire hydrants, or valves. Easements must be project-specific.

Construction easements may differ from standard utility O&M easements because they are temporary. Construction easements may be needed when additional space is needed for staging material and equipment, installing the facility, or temporary access to the construction site.

Table 5-16 lists SPU minimum width requirements for permanent water main easements. This table is a guideline. Engineering judgment and future expansion may require larger easement areas. Easements should be sized to allow for future maintenance and or replacement of the facilities. The size of the easement area for water infrastructure is also subject to the specifics of the site.

Easements are not used in City-owned public ROWs. Where SPU needs space in public ROWs governed by other jurisdictions, a franchise permit is obtained.

Note: SPU prefers to purchase property and own the land where facilities are installed. However, SPU realizes this is not always possible.

Table 5-17
SPU Minimum Water Easements

Inside Pipe Diameter or Nominal Pipe Diameter (inches)	Minimum Easement Width (ft)
<8 to 24	15
30 to 92	30

5.13 RESOURCES

Documents

- Burlington Northern Santa Fe (BNSF) [Utility Accommodation Policy](#), October 16,2020
- Burlington Northern Santa Fe (BNSF) [Design Guidelines for Industrial Track Projects](#), 2023Sound Transit Design Criteria Manual
- American Water Works Association (AWWA) [Design Manuals for Water Supply Practices](#)
- American Water Works Association (AWWA) Pipe Materials Selection Manual
- American Water Works Association (AWWA) Potential Techniques for the Assessment of Joints in Water Distribution Systems
- American Water Works Association (AWWA) Maintaining Water Quality in Finished Water Storage Facilities
- American Welding Society (AWS): D1.1 [Structural Welding Code](#), Section 3; Workmanship
- Washington Administrative Code (WAC); Chapter 246-290, Cross-Connection Control [Public Water Supplies](#)
- Washington State Department of Health; Division of Drinking Water; [Water System Design Manual](#)
- Washington State Department of Health; [Pipeline Separation Design and Installation Reference Design Guide, Version 9](#)
- Seattle Parks Department; agreement on multi-use reservoir sites.
- [Seattle Public Utilities; Water System Plan – 2019.](#)
- Trenchless Technology: Pipeline and Utility Design, Construction, and Renewal. Najafi, Mohammad, PhD, PE. WEF Press, 2004
- [Performance Based Seismic Design for LADWP Water System Final v1.0](#)
- [Final Summary Report Water System Seismic Resilience and Sustainability Program for LADWP](#)

Removed for Security

