

# Chapter 4 General Design Considerations

<b>Chapter 4</b>	<b>General Design Considerations.....</b>	<b>4-1</b>
<b>4.1</b>	<b>Key Terms.....</b>	<b>4-1</b>
4.1.1	Abbreviations .....	4-1
<b>4.2</b>	<b>Presentation Standards .....</b>	<b>4-2</b>
4.2.1	Drawings and Drafting Standards .....	4-2
4.2.2	Asset Identifications.....	4-3
<b>4.3</b>	<b>Access.....</b>	<b>4-3</b>
4.3.1	Vehicular Access .....	4-3
4.3.2	Pipeline Access.....	4-6
4.3.3	Controlled Access with Fencing and Gates .....	4-7
<b>4.4</b>	<b>Structures .....</b>	<b>4-7</b>
4.4.1	Loads .....	4-8
4.4.2	Access to Structures, Doors, Castings, and Ladders.....	4-11
4.4.3	Waterstops and Structure Penetrations.....	4-14
4.4.4	Concrete, Curing, and Coatings .....	4-15
4.4.5	Vehicle Loads .....	4-15
4.4.6	Seismic .....	4-15
4.4.7	Soil Design Parameters.....	4-15
4.4.8	Roofs .....	4-15
4.4.9	Finishes.....	4-16
<b>4.5</b>	<b>General Pipe Connections and Supports .....</b>	<b>4-16</b>
4.5.1	Facility Piping Connections.....	4-16
4.5.2	Pipe Supports .....	4-17
<b>4.6</b>	<b>Equipment Anchorage .....</b>	<b>4-20</b>
<b>4.7</b>	<b>Utility Services at SPU Facilities.....</b>	<b>4-21</b>
4.7.1	Power.....	4-21
4.7.2	Water and Fire/Hydrant Service.....	4-21
4.7.3	Sewer and Drainage .....	4-21
4.7.4	Communications/Telephone.....	4-21
<b>4.8</b>	<b>Pipeline and Conduit Corridors at SPU Facilities .....</b>	<b>4-21</b>
<b>4.9</b>	<b>Temperature and Ventilation Requirements .....</b>	<b>4-22</b>
4.9.1	Ventilation.....	4-22
<b>4.10</b>	<b>Landscaping and Irrigation .....</b>	<b>4-22</b>
4.10.1	Landscape Design.....	4-23

- 4.10.2 Landscape Plan .....4-24
- 4.10.3 Irrigation Plan .....4-25
- 4.11 Casing Pipe ..... 4-26**
  - 4.11.1 Casing Pipe Material .....4-26
  - 4.11.2 Minimum Casing Diameter .....4-26
  - 4.11.3 Minimum Casing Thickness .....4-26
  - 4.11.4 Installation Considerations for Future Access and Carrier Pipe Replacement .....4-28
  - 4.11.5 Spacers and End Seals .....4-28
  - 4.11.6 Cathodic Protection .....4-28
- 4.12 Resources and Links for Stormwater Code Compliance ..... 4-29**
  - 4.12.1 Determine Project Minimum Requirements.....4-29
  - 4.12.2 Construction Stormwater and Erosion Control .....4-30
  - 4.12.3 On-Site Stormwater Management.....4-31
- 4.13 Restoration of Disturbed Areas ..... 4-32**
- 4.14 Signs at SPU Facilities..... 4-32**
- 4.15 Geotechnical Services ..... 4-32**
- 4.16 Future Expansion Considerations ..... 4-33**
- 4.17 Resources ..... 4-33**

**Appendices**

Appendix 4A - Vector Truck Turning Radius

**List of Figures**

- Figure 4-1 Typical Turning Radius for 55-ft Semi-Trailer.....4-4
- Figure 4-2 Typical Details of Pipe Supports 1 ..... 4-18
- Figure 4-3 Typical Details of Pipe Supports 2 ..... 4-19

**List of Tables**

- Table 4-1 Pipe Connection Types and Uses..... 4-16
- Table 4-2 Minimum Steel Casing Pipe Thickness for Road and Highway and Rail Applications<sup>1-4</sup> ..... 4-27
- Table 4-3 Links to General Stormwater Code Information ..... 4-29
- Table 4-4 Links with Information on CSEC ..... 4-30
- Table 4-5 Links with Information for Design of On-Site Stormwater Management (GSI) ..... 4-31

# Chapter 4 GENERAL DESIGN CONSIDERATIONS

This chapter of the Design Standards and Guidelines (DSG) presents standards and guidance for general design, including design considerations and standards that are not specific to water, drainage, or wastewater infrastructure. The primary audience for this chapter is SPU engineering staff. DSG standards are shown as underlined text.

## 4.1 KEY TERMS

Abbreviations and definitions given here follow either common American usage or regulatory guidance.

### 4.1.1 Abbreviations

Term	Abbreviation
ADA	Americans with Disabilities Act
AASHTO	American Association of State Highway and Transportation Officials
CAM	Client Assistance Memorandum
City	City of Seattle
CSEC	Construction Stormwater and Erosion Control
DWW	drainage and wastewater
ft	feet
FRP	fiberglass-reinforced plastic
GSI	Green Stormwater Infrastructure
LOB	line of business
O&M	operations and maintenance
ROW	right-of-way
SCADA	supervisory control and data acquisition
SCL	Seattle City Light
SDCI	Seattle Department of Construction & Inspections
SDOT	Seattle Department of Transportation

Term	Abbreviation
SMC	Seattle Municipal Code
WISHA	Washington Industrial Safety and Health Act

## 4.2 PRESENTATION STANDARDS

This section describes standards for drawings, notes, and specifications and explains the importance of standardized format for the City of Seattle's (City's) record keeping and in communicating with the Contractor. See section 3.4 of [DSG Chapter 3, Design for Construction](#), for constructability tips and the use of notes on the drawings.

### 4.2.1 Drawings and Drafting Standards

There are two documents that contain all the information on SPU's drawing and drafting standards: the Computer-Aided Design (CAD) Manual and the CAD Manual Appendices. Both of which are available on the [SPU's CAD Resources website](#).

Corporate data, including the record drawings, is an important and critical asset to the City. Managing construction records data is essential to the data-driven decision-making mode that empowers SPU to manage the City's assets. Creating engineering drawings and documents to a common standard allows for better management and use of engineering data. Common SPU and Seattle Department of Transportation (SDOT) standards aid communications with reviewers during plan development and with contractors that work frequently within the City.

Applying drawing and drafting presentation standards also makes the engineering data compatible with Geographic Information Systems (GIS)s. These standards also promote an efficient work environment using modern engineering principles and allow SPU to reuse and build data for future projects, studies, and initiatives, and help SPU to better manage design costs.

Use of the SPU/SDOT Inter-Departmental CAD Standard is a requirement in consultant contracts (see [SPU's CAD Resources website](#) for specifics). These standards can run counter to usual practices at many firms, and there are many reasonable ways to present the same information. Therefore, carefully review and discuss the standards with the project team to decide on the type of drawings to present that will be the clearest for the Contractor. Especially with data for underground infrastructure, decide whether a combined utility sheet is appropriate or if it would be beneficial to view the sewer and drainage standards together. SDOT's current standard for Street Improvement Permit plans is to show all the street improvements on a single sheet with discipline sheets to follow. However, this is not generally appropriate for SPU projects but could make sense on less complex or parcel-centric projects. Decide the project's approach based on what will more clearly communicate essential information to the Contractor, not what is convenient for the stamping engineers.

## 4.2.2 Asset Identifications

A variety of asset identifiers are needed for construction. See section 1.6.3.3 of [DSG Chapter 1, Design Process](#).

## 4.3 ACCESS

---

This section describes typical design considerations related to the ongoing access requirements for SPU-owned and operated infrastructure and facilities. See section 11.6.1.1 of [DSG Chapter 11, Pump Stations](#) for pump station access.

### 4.3.1 Vehicular Access

Design engineers must consider vehicular access constraints for operations and maintenance (O&M) activities, future rehabilitation or replacement, safety, and traffic impacts.

#### 4.3.1.1 Parking

Early in the design process, preferably during preliminary engineering, confer with SPU Operations staff to determine minimum parking requirements for the project. It is typical that space for two vehicles is required, but the space, need, and frequency of use can vary. Determine whether some access is required 24/7 for emergency response or if “no parking” signs set up three days ahead will be sufficient. Also, check whether infrequent maintenance activities or rehab and replacement would require staging of multiple vehicles or special equipment.

Many parking requirements are documented in Seattle Department of Construction & Inspections’ (SDCI’s) [land use codes](#). Early consultation with the regulating authority is recommended. Parking restrictions within a City right-of-way (ROW) require early negotiation with SDOT on a case-by-case basis.

Parking for maintenance vehicles should be located so that the vehicle can be parked without interfering with normal road traffic. Whenever possible, parking should be provided on-site and not within the ROW. Staff should be able to:

- Safely access the facility without the need to cross traffic
- Safely enter and exit the parking space without special traffic controls or directing traffic
- Obtain tools and specialty equipment stored next to the facility

The recommended parking stall size is 9 feet (ft) wide and 20 ft long. This size of stall can accommodate most maintenance vehicles (e.g., boom trucks, trailers with portable generators, or Vactor trucks). Always check the size of the specific equipment needed for the facility, including vehicles with outriggers.

Pull-through spots are most desirable, especially for large vehicles or vehicles towing a trailer, where backing can be a significant safety issue.

Parking restrictions within the ROW should be marked with both paint channelization and a parking restriction sign (signed for exempt vehicles only), to minimize the conflicts and need to tow.

See section 11.6.1.2 of [DSG Chapter 11, Pump Stations](#) for pump station parking.

### 4.3.1.2 Turning Radii

Turning radii for vehicles must be considered both in roadways when designing utility access points and in parking, because the tightest corners large vehicles must maneuver are usually in parking lots. Dead-end streets and alleys are also a unique concern for SPU truck drivers. A typical truck's turning radius design diagram for a 55-ft semi-trailer is shown in Figure 4-1 and is a conservative choice for most SPU vehicles. SDOT typically uses a single-unit vehicle with a 42 ft turning radius for intersection design. American Association of State Highway and Transportation Officials (AASHTO) guidelines should be adhered to for all vehicular access design, especially truck turning radii. Design engineers should consider all types of vehicles that may need to access a site and confer with Operations staff early in the design process, preferably during preliminary engineering.

**Figure 4-1**  
Typical Turning Radius for 55-ft Semi-Trailer

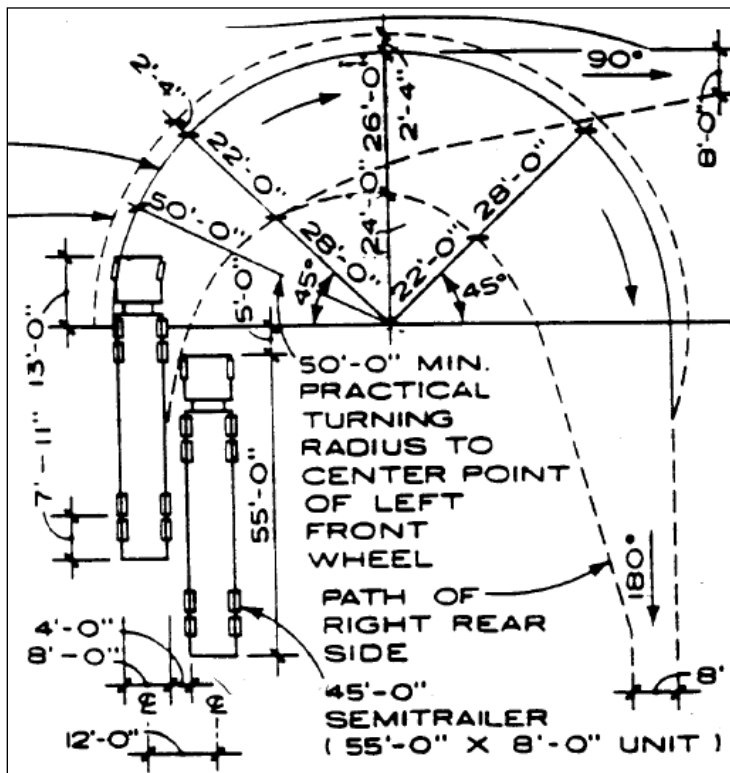

### 4.3.1.3 Access Roads

Access roads can be needed for a variety of reasons and are typically outside of the ROW. Confer with Operations staff early in the design process about what types of vehicles will need to access a facility and frequency of access. In general, SPU prefers:

- Pull-through access roads that do not require backing
- 20 ft clear width with a 12 ft minimum width
- A road section and wearing surface for heavy truck loads, to reduce maintenance required for the road
- Shared uses are typically acceptable

#### 4.3.1.4 Special Equipment Access

The design engineer should consider a plan for access of special equipment used during maintenance activities, such as removing and replacing equipment, periodic cleaning, when removing and replacing equipment, and when installing new facilities. Design decisions can be informed by the size of the special equipment and/or the number of vehicles required for efficient material handling. When anticipating multiple vehicles, it becomes even more important to eliminate backing movement requirements.

**Tip:** *Remember to look up and establish overhead clearance requirements (equipment needs to stay away from power lines at least 10 ft, or more if higher voltage) in addition to side-to-side and below-grade movements. Ask surveyors to locate overhead information, including wires, and ask base map researchers to check for hidden foundation information.*

##### A. Cranes

Heavy equipment such as pumps and motors should be accessible by boom truck or mobile cranes, unless alternative lifting equipment such as a monorail is provided. Typically, SPU will choose to rent a crane and operator instead of adding fixed equipment that needs regular inspection and maintenance. However, site-specific conditions may dictate otherwise. Therefore, involving Operations to receive input regarding site-specific needs for such equipment is recommended.

Boom trucks and cranes require relatively even ground to position for operation with sufficient room for outriggers for stabilization and to maintain uniform clearance from overhead obstructions, such as power lines. Projects should identify a method and type for moving equipment during preliminary engineering. The clear space for a crane with outriggers and overhead clearances are very likely to be critical space constraints.

##### B. Vector Trucks

Most facilities will require access for a Vector truck. See [Appendix 4A - Vector Truck Turning Radius](#) for the turning radius for the large Vector truck currently in the SPU fleet. Because effective suction requires the truck to be within approximately 28 ft, it is important to allow truck access close to any below-grade facility needing suction. To accommodate effective suction, SPU's preferred maximum depth of facility from surface to interior bottom needing suction is 17 ft.

##### C. Portable and Standby Generators

Most facilities will require a standby generator. This will require access and parking for a fuel truck. The design engineer must consider ample space close to facilities for parking and connection of a portable generator in case of standby generator failure. Generator sizing is dependent on facility-specific energy generation needs. SPU generators vary from 1 kilowatt (kW) to 1 megawatt (mW) capacity, ranging in size from handheld to the size of a shipping container. The design engineer must determine power generation and facility criticality requirements for the site and then estimate the size of a portable generator accordingly. This should involve assessment of facility criticality and available space as to whether a standby generator should be proposed, or a portable device with an E-plug. Discuss these needs with Operations and LOB as part of the design scope.

## 4.3.2 Pipeline Access

### 4.3.2.1 Clearances for Excavation and Shoring

Within the City's ROW, horizontal clearances of 5 ft from outside of pipe are generally sufficient for installation of shoring to support future excavation. Within easements, horizontal clearances should provide sufficient space for construction equipment. See section 5.12.1 of [DSG Chapter 5, Water Infrastructure](#) and section 8.12 of [DSG Chapter 8, Drainage and Wastewater Infrastructure](#). Vertical clearance needs will vary. For any location where safe vertical clearances from overhead obstructions, including power, cannot be maintained for excavation equipment needed in the future, consider alternative access (see DSG section 4.3.2.4).

### 4.3.2.2 Clearances for Services

Unless there is a clear reason that future services would not be feasibly connected to an SPU pipeline, design should maintain a clear space for access, both vertically for the service lateral and horizontally for access to tap or core tap. A 5-ft clearance is needed for tapping equipment. Drainage and wastewater (DWW) core taps require a minimum of a 3-ft clearance. With the deeper excavation and the need for shoring at the tap location, 5-ft clearance is also likely required.

### 4.3.2.3 Clearances from Trees

When feasible, design for clearances greater than the 5 ft to provide clearance from the edges of trees to outside of pipe. The clash between mature trees and maintenance vehicles or the excavation necessary for repairs and services can be costly to the utility and devastating for the tree.

A minimum horizontal clearance of 5 ft is not fully protective of pipe from potential damage from tree roots. A 5-ft clearance does not fully protect tree canopies or roots from utility excavation or maintenance activities. The minimum 5-ft clearance is based on an agreement between SDOT and SPU that can be found in the agreement's library.

### 4.3.2.4 Alternative Access

Various means are used to provide non-standard access for replacing SPU utilities. Below are options when standard access is either not possible or in direct conflict with another City goal.

#### A. Casings

See DSG section 4.11 and section 5.6.3.7 of [DSG Chapter 5, Water Infrastructure](#). Identify sufficient space on at least one side of a casing to excavate and pull existing pipe sections and assemble and push-replacement pipe through the casing.

#### B. Tunneling and Drilling

See section 5.8.3.8 of [DSG Chapter 5, Water Infrastructure](#) for information on tunneling and drilling.

#### C. Within a Structure

Identify access for maintenance and repairs within a structure, eliminating the need for access through an excavation. Truck access near an access structure is strongly desired even when excavation will not be required. See DSG section 4.4.1.

## D. Clearance from Underground Power

See Seattle City Light (SCL) [Construction Standard 0214](#) for standard minimum separations between water, sewer and drainage, and underground power. This standard indicates the minimum separations that SPU has approved. SCL engineers must coordinate with interested parties when these minimum separations cannot be maintained.

SCL Construction Standard 0214 identifies SCL clear zones. For SPU assets to be placed in an SCL clear zone, SCL, SPU, and SDOT should coordinate to resolve the conflict. Common conflicts over utility separations are a result of shifting curbs. One example is needing to place drainage structures over the top of a duct bank, which SCL standards do not permit.

It is important to resolve these contradictory design issues prior to advertising. In addition to the usual issue of obtaining permission to advertise, [City Standard Specifications section 1-04.2](#) indicates that referenced SCL standards supersede the drawings.

### 4.3.3 Controlled Access with Fencing and Gates

Fencing is regulated through SDCI's land use code. In addition, the design engineer should discuss fencing needs with both SPU Security and Operations staff early in design, including discussions on vegetation and trees in proximity to a fence. It is preferable to identify SPU security and maintenance needs prior to design review, artist input, or community outreach efforts, all of which can make demands on fence and screening design. Consult with SDOT before scoping any gate that can swing into the City ROW, since the swing can have significant impacts on street and sidewalk functions.

Any locked facility design requires coordination with SPU Security and Operations staff. The Project Manual should include requirements for locks that meet SPU standards and transfer from the Contractor.

See section 11.6.1.4 of [DSG Chapter 11, Pump Stations](#) for fencing at pump stations and sections 15.4 and 15.5 of [DSG Chapter 15, Physical Security](#) for physical security measures and electronic physical security equipment

**Tips:** *SPU does not typically use chain-link fencing and gates, as shown in the [City's Standard Specifications and Plans](#). The swing gate shown in the standard can be a hazard to traffic, both in the swing mechanism and for a truck waiting. The gate length needed for large truck access can also result in fence-sag and be a fence-maintenance nuisance.*

*Coordinate fencing choices with landscaping. Both SPU Security and Operations staff should have input. Fencing choices like chain link can seriously complicate gardening maintenance activities.*

## 4.4 STRUCTURES

This section discusses general design considerations for SPU structures. Major structures will be designed by a licensed structural engineer or licensed civil engineer with competency in

structural design and should follow all applicable design codes and City policy on environmental design. Early determination of measurable environmental design requirements, such as Leadership in Energy and Environmental Design (LEED) goals, is critical for scoping new structures. Design of pipeline structures, including access requirements and structures, is addressed in [DSG Chapter 5, Water Infrastructure](#) and [Chapter 8, Drainage and Wastewater Infrastructure](#).

Modifications to existing structures are frequently needed as part of retrofit and rehabilitation projects. These modifications, such as new or expanded openings and seismic retrofits must be designed by a licensed structural engineer.

## 4.4.1 Loads

### 4.4.1.1 Design Loads

This section describes the typical design loadings assumed for SPU buried structures, including walls, slabs, platforms, and other features. The guidelines were originally derived for pump stations, and these general design principles apply broadly to buried structures. Specific design criteria are always the responsibility of the engineer to determine. Actual design loads outlined below may be higher at some sites and must be verified by the design engineer. Load combinations should be per ASCE 7, chapter 2.

#### A. Exterior Walls

Structural loads sustained by exterior walls of buried SPU structures, such as pump stations, vaults, and similar, should generally include soil, surcharge, seismic, and hydrostatic lateral loads. Because of the rigid nature of the structure walls being supported laterally at the base and top slab, typical lateral soil loads for most structures are from at-rest soil. Surcharge loads are due to vehicles, equipment, or piled soils adjacent to the walls.

Numerous design manuals provide methods for estimating lateral soil loads created by distributed, line, or point loads. SPU projects commonly refer to the Naval Facilities Engineering Command (NAVFAC) Design Manual (DM) 7.1. Surcharge loads typically need only be applied to a depth 10 ft below ground surface. Lateral seismic loads are calculated based on expected ground accelerations and soil types and are determined through site-specific geotechnical exploration and analysis. Hydrostatic loads result from groundwater. Groundwater elevation, and thus hydrostatic loads from groundwater, must be determined by site-specific geotechnical exploration and analysis. Table 1117 below shows typical lateral loading parameters, which can be used as a general guideline where no site-specific geotechnical analysis is available.

**Table 1117**  
**Typical Lateral Loading Parameters**

Parameter	Value
At-rest lateral load, above groundwater	60 pcf equivalent fluid pressure

At-rest lateral load, below groundwater	35 pcf equivalent fluid pressure
Soil surcharge	120 psf
Soil seismic	20 x interior wall height, psf
Hydrostatic	62.4 psf fluid pressure

## B. Top Slabs for Buried Structures

Top slabs may be buried at grade. Top slabs are typically required to resist the following types of loads:

- Concrete roof, with a typical dead load of 150 pounds per cubic ft (pcf)
- Soil, with a typical dead load of 120 pcf.
- Pavement, either concrete or HMA with a typical dead load of 145 pcf.
- Aggregate base under pavement with a typical dead load of 130 pcf.
- Snow load up to 25 pounds per square ft (psf).

Vehicle loading when vehicle access is possible over top slab, with loads consisting of 32-kip axle load at 14-ft spacing or tandem 25-kip axle loads at 4-ft spacing. American Association of State Highway and Transportation Officials [AASHTO] HL 93 [loading](#) can serve as a design guide. For top slabs with 2 ft or less soil cover, a 1.3 impact factor should be added to this vehicle live load. Where top slab is inaccessible to vehicle traffic, SPU recommends a minimum 300 psf live load.

Construction loads should be determined on a project specific basis. Wall backfill prior to top slab construction is one possible example.

## C. Bottom Slabs

Bottom slabs are typically required to handle bearing loads and uplift from hydrostatic water pressure. Bearing loads generally consist of dead and live loads on the top slab, weight of the walls, and weight of the bottom slab distributed over the area of the bottom slab. Structural engineers may also need to consider stability-related foundation reactions when evaluating bearing loads on a bottom slab.

## D. Gratings and Suspended Platforms

Many of the suspended platforms at SPU buried structures are constructed of grating supported by beams. The grating should be designed to handle the same loads as the associated suspended floor design. At minimum, the grating should be designed for a load of 100 psf with a maximum deflection of  $\frac{1}{4}$  inch. The NAAMA Metal Bar Grating Manual provides grating design guidance. Hot-dip galvanized grating, which allows for future field modifications, should be used in most cases. Grating design and support systems must consider and allow for future penetrations for piping and conduit. Often framing is required to support the grating edges around such penetrations. Grating should be fully banded along all edges and openings. SPU generally does not prefer the use of FRP gratings. If FRP gratings are required due to site-specific conditions, coordinate with SPU Operations.

### E. Guardrail

Per ASCE 7, chapter 4, pedestrian guardrail design load must be 200 lbs at any point and in any direction along the top rail, or a uniform load of 50 lb/ft along the top rail. Pedestrian guardrails are required to meet Occupational Safety and Health Administration (OSHA) requirements for fall protection open spacing, which requires a two-rail system. If the public has access to the structure, as defined in SBC, the pedestrian guardrail must not allow a 4-inch ball to pass through the guardrail. Provide kickplates for all guardrails.

### F. Ladders

Ladders at SPU buried structures should be designed to handle the following loads:

- Ladder supports (standoffs) should handle two 250-lb loads located between two consecutive ladder supports.
- Ladder rungs must be capable of handling a 250-lb load at the center of the rung.
- Minimum ladder rung length between side rails is preferred to be a minimum of 16 inches.
- A minimum of 15-inch clearance between walls and the center of the ladder is required.
- The above ladder load requirements are based on OSHA 1926.1053.

For ladders which provide access to platforms or roofs and do not project above that level, install a retractable ladder safety post such as the 'Ladder-Up' by Bilco, or similar.

### G. Slide Gate Supports

When gate operator loads are placed on the structure, such as on interior platforms or top slabs, the design loads of the load-bearing feature must be the load created by the stall torque of the actuator motor. This may be as much as four times the rated load. Slide gates with a hand actuator should assume a 40 lb effort on the handwheel or crank.

## 4.4.1.2 Load Cases

### A. Stability and Buoyancy

Generally, the design of buried structures does not need to consider overturning stability. However, overturning stability should be considered if the buried structure is partly buried, with one side more exposed than the opposite side. In this situation these uneven soil loads need to be considered when calculating overall stability and foundation reactions. The pump station buried structure should be designed to ensure that resultant the resultant of the stability reactions is within the mid-1/3 of the base, resulting in bearing pressure over the entire foundation. Stability cases should consider static, dynamic, and buoyancy loads.

Design of below-grade structures must consider buoyancy. The groundwater surface should be as recommended by the geotechnical engineer. If no geotechnical information is provided, the groundwater surface should be assumed to be at the ground surface for design purposes. The uplift load due to buoyancy is equal to the

volume of water displaced. The resisting loads include the dead load of the structure, possible overburden over the top of the structure, possible soil load over any foundation extension beyond the exterior wall, and soil surface friction. For soil load over foundation footing extensions, the design should use the buoyant unit weight of the soil. It is recommended to ignore soil friction against the exterior wall surface because friction can be greatly reduced in the event of soil liquefaction during a seismic event. The minimum factor-of-safety for buoyancy must be 1.2.

## B. Durability

The structural engineer can ensure durability for concrete construction using the following methods:

Concrete mix, a minimum 28-day compressive strength of 4,000 psi and a maximum water/cementitious ratio of 0.42. This guideline generally follows the requirements of ACI 318.

- Use of the appropriate cement type in the concrete based on possible soil conditions. Concrete using type II cement (moderate sulfate resistance) is typically adequate. If a soil investigation indicates more a more severe sulfate attack, type V cement may be appropriate. Generally, type III cement (high-early strength) should be avoided because of its higher heat of hydration, which can result in additional cracking.
- Concrete cover over reinforcement for both interior and exterior walls should be 2 inches minimum.
- Minimum reinforcement requirements (for crack control) should follow ACI 350's guidance for higher reinforcement requirements based on distance between control joints.
- Concrete mix requirements regarding alkali/silica reactivity should be included in the project structural concrete specifications. Such requirements are included in the [City of Seattle Standard Specifications](#) but may not be included by default in a CSI type specification.

### 4.4.1.3 Anchors

Anchor bolts are designed in accordance with ACI 318, chapter 17. This includes cast-in-place, adhesive type (epoxy), and mechanical type (expansion) anchors. Anchors should be constructed of the same type of material as the member being anchored. However, aluminum or fiberglass members should use stainless-steel anchors. When anchoring machinery, use cast-in-place or adhesive type anchors. For wall-mounted anchors such as pipe supports or ladders, either adhesive or mechanical type is acceptable. For ceiling mounting, mechanical anchors are recommended.

## 4.4.2 Access to Structures, Doors, Castings, and Ladders

Structure access is essential for maintenance, operation, cleaning, testing, repair, and replacement of critical infrastructure. Safe access is required but can be challenging to achieve.

Safety issues that the design engineer should consider include but are not limited to:

- Unassisted lifting restriction of 50 pounds
- Confined space entry and rescue/retrieval
- Head protection and fall protection
- Size of ingress and egress
- Pinch points
- Passing vehicle and passing pedestrian traffic

SPU prohibits some employees from performing unassisted lifting of any object that weighs over 50 pounds. Many SPU maintenance vehicles have 1-ton lift assistance, so it is important that vehicles and booms can be stationed close (generally within 15 feet) to utility access points, especially for openings used for installation and removal of equipment.

Entering a confined space, such as a vault or maintenance hole, will require the use of a tripod or other fall protection/retrieval means, safety harnesses, gas monitoring, and safety equipment (such as blowers or temporary ventilation) as required by applicable confined space entry procedures and regulations.

Use railings and landings, cage ladders, ladder fall prevention safety systems, and fall protection grating as required by building codes and Washington Industrial Safety and Health Act (WISHA) rules to prevent and restrict falls. Ladder fall prevention safety systems such as fall arrest cables are required on ladders over 24 ft in height. Ladder cages are not considered a fall prevention method but may be installed on ladders to reduce apprehension on tall ladders and provide lean-back rest points. Place ladders to clear openings and provide head space of a minimum 6 ft for occasionally accessed structures. More clearance is desirable, if possible. More clearance is required for regularly accessed structures. For ladders that do not extend above the surface elevation, it is mandatory to install a retractable safety post, such as the 'Ladder-Up' (Bilco), to assist users in accessing the ladder.

Size doors, hatches, and other access for equipment to be installed and removed without dismantling, whenever possible. Add sufficient space to reduce pinch points between the opening and other equipment. Hatches for equipment access may be too large for a retrieval tripod to be safely used to support confined space entry. For these hatches, install a davit socket and removable davit arm adjacent to the ladder. Storage for the davit arm must be provided on site.

For access points to large, deep, or irregular openings, consult with SPU Operations and Maintenance to determine if fall protection gratings should be provided below castings and hatches.

### 4.4.2.1 Hatches and Castings

In general, SPU prefers castings over hatches for access points. All castings and hatches must be designed for AASHTO HS25 loading, minimum. Consider impact loading where applicable.

Locate utility access points to allow for good traffic control of both vehicles and pedestrians. To the extent feasible, locate castings to ensure that traffic lanes in all directions can be maintained around open hatches or castings. This can be particularly difficult in intersections. To reduce noise and wear on castings, try to avoid locating these in wheel-tracks. Avoid driveways, as they are difficult to shut down to access hatches and castings.

Vault covers, castings, and drainage grates may pose hazards to pedestrians. These features should not be placed within a crosswalk, curb ramp, or landing area behind or in front of the ramp. Locate hatches and castings to minimize pedestrian safety issues related to slipping and closures of crosswalks, sidewalks, and ramps during use. In cases where you cannot identify a feasible alternative, identify the conflict and work with SDOT to minimize hazards and inconvenience for pedestrians and to satisfy Americans with Disabilities Act (ADA) requirements. Slip resistant covers meeting SCL Material Standard 7203.10 must be provided in all pedestrian traffic areas. Where open hatches pose a fall hazard to pedestrians, consider providing built-in safety measures for hatches such as removable posts and chains.

Hatches are difficult to set within pavement and need to be adjustable to match the surrounding grades, while still freely opening. Hatch drains must also be provided and routed to an adjacent drain or sewer. Where no piped discharge is available, hatch drains may be discharged to a rock pocket.

Prior to the start of any roadway construction, identify all SPU castings in the pavement area and identify worn or substandard castings that need to be replaced. Replace existing 18-inch SPU castings with new castings meeting current standards (Type 230 minimum, or larger if required). [Standard Plan 220](#) shows a typical maintenance hole rebuild detail. Identify on the drawings whether SPU or the Contractor is responsible for the replacement or adjustment.

#### 4.4.2.2 Gratings

Gratings are required in many SPU facilities and can promote better ventilation and be helpful for visual inspections. For maintenance activities and removing equipment, facilitate easy removal of both the grating and the support system, if necessary. Sections intended for regular removal should be hinged where possible, and in all cases laid out in sections that are easily removable by a single worker while minimizing potential fall hazards.

Gratings and grating support systems can be a variety of materials, depending on the anticipated loading and environment. In general, SPU prefers metallic gratings for ease of installation and field modification. If maintenance activities could require kneeling on the grating, consider, and discuss with SPU Operations staff, the trade-off between anti-slip properties and knee and hand injuries.

Galvanized grating should be by the hot dip process in accordance with ASTM International (A123). Galvanized materials are not appropriate for use in drainage facilities, since the zinc material is a pollutant that can be released into a waterway. Grating should be designed for a uniform minimum distributed live load of 100 pounds per square ft (psf), with a maximum live load deflection of 1/4 inch, or the calculated anticipated applied loads (such as pump weights), whichever is greater. Gratings should be designed and fabricated in accordance with NNSI/NAAMM MBG 531, the Metal Bar Grating Manual type W-19-4. The weight of grating or plate segment should be limited to a maximum of 50 pounds for any material that may need to be lifted by hand. If using marine-grade coatings on steel bar grating, do not use zinc-based paints in drainage applications.

If using fiberglass-reinforced plastic (FRP) to combat corrosion, gratings should be one-piece molded construction suitable for stair treads, platforms, or walkways and have a slip resistant surface. SPU requires ultraviolet (UV) inhibitors for all FRP grating and supports exposed to sunlight. Because the manufacturer's engineer is typically responsible for design of FRP grating and supports, it is important that the design show details of critical clearances, all openings, and

span restraints when needed. Field modifications of FRP gratings must be reviewed by the manufacturer.

### 4.4.2.3 Stairways and Ladders

Stairways and ladders should conform to building codes and WISHA rules. In addition, design for railings that can be gripped well with both a bare and a gloved hand. Design for visual clues should be so that these can be followed even in low-light environments. Where ladders are constructed of galvanized steel, use manufactured galvanized steel treads, such as TRACTION TREAD by McNichols.

If considering FRP for handrails, grating, or treads, be aware that FRP can degrade and shed fibers over time, which can puncture crew members in their hands or through clothing.

### 4.4.2.4 Doors

Doors should be large enough to allow equipment removal and replacement. Anticipate that above-door lighting will be needed. Consult early with SPU Security staff on requirements for locks, SAID card readers, and other required security measures. See [DSG Chapter 15, Physical Security](#). Prior to bidding, consult with SPU Operations on hardware preferences. SPU maintains some hardware within the warehouse for cases where compatibility with existing hardware is needed.

### 4.4.2.5 Clearances in a Structure

Drawings should show details of equipment and clearances to allow users to review during the design process. See Section 10.5.3.2 of [DSG Chapter 10, I&C \(Supervisory Control and Data Acquisition \[SCADA\]\)](#) for standard electrical and instrumentation working clearances.

## 4.4.3 Waterstops and Structure Penetrations

Many SPU structures need to be watertight to hold water or to exclude groundwater. For cast-in-place structures, the contract documents should address the control of the concrete pours to provide continuous structural elements and should show the allowable construction joints and expansion joints. Polyvinyl chloride (PVC) or hydrophilic water stops are required at all joints that will be or could be, under water. Penetrations of the structure for pipes, conduits, hatches or castings have the potential for leaks and allowable waterproofing methods and products should be specified by the design engineer. In addition to grouting, boots, or cast-in-place products, it is good practice to slope connecting pipes and conduits away from the structure penetration, when possible, to minimize water ingress to the structure and any connected equipment.

Pre-cast structures, which are generally designed by the manufacturer's engineer, can have many more joints than a cast-in-place structure, because of the need to ship and handle the structure in smaller pieces. Carefully specify requirements for a watertight structure, especially for multiple-joint structures such as panel vaults. Waterproof membranes or coating systems can also be considered.

Contract documents should specify testing requirements and allowable leakage for structures. Testing can be completed by filling the structure with water and checking for leaks or damp spots or by air pressure loss or vacuum loss, depending on the structure. Since watertight structures can be difficult to construct, the design engineer should also specify possible repair

methods. Use caution when specifying exfiltration testing for structures to be coated, as it may be difficult to dry and prepare surfaces for coating after they are fully saturated.

#### 4.4.4 Concrete, Curing, and Coatings

Consult with the SPU Materials Lab for assistance on structural concrete specifications. Also, ask for advice with constructability considerations, such as acceptable concrete slump in dense rebar locations like wall-to-floor connections.

Sometimes the SPU Materials Lab can provide special inspectors to support the inspections required by an SDCI permit.

Special coatings are available for a multitude of purposes and are constantly changing. Consult with manufacturers for current information.

#### 4.4.5 Vehicle Loads

All new structures subject to traffic loading must incorporate AASHTO HL-93 load criteria to use 40k axle loads.

Impact loadings should be calculated in accordance with AASHTO Standard Specifications for Highway Bridges. For pipelines, valves, meters, and similar structures, the impact factor should be 50% and should not vary with depth of cover. For pipelines over 12 ft deep, impact generally does not need to be considered as loads can be effectively dissipated below this depth.

#### 4.4.6 Seismic

Seismic design requirements for new water pipelines and facilities are described in section 5.10 of [DSG Chapter 5, Water Infrastructure](#). Consult with the SPU Geotechnical Engineering group and refer to section 5.9.2.1 of [DSG Chapter 5, Water Infrastructure](#) for seismic design geotechnical parameters and considerations. See section 3.15 of [DSG Chapter 3, Design for Construction](#) for a description of geotechnical services.

#### 4.4.7 Soil Design Parameters

Geotechnical design criteria, including allowable bearing pressures, lateral pressures, and minimum footing depth and width requirements, will vary for each site and should be determined in each case based on the site-specific geotechnical report. See section 3.15 of [DSG Chapter 3, Design for Construction](#).

#### 4.4.8 Roofs

When selecting roof shape and materials, maximize the design life of the roof. Re-roofing carries major project costs and coordination with operations beyond the cost of the new roof material. Lifecycle costs for a roof can be distorted by City contracting processes.

Avoid flat or low-slope roof designs to avoid maintenance problems in the future. Keep the roof slope to a minimum of two percent, but avoid steep slopes to allow safe access for workers.

See also the [City of Seattle Stormwater Manual](#) on vegetated roofs. Metal roofs are only acceptable if they have an enamel coating; other coatings are considered a pollutant source in stormwater.

### 4.4.9 Finishes

Above-grade exterior structural finishes will be influenced by design review, artist input, and community outreach efforts, as well as building codes. In addition, consider theft-preventive and graffiti-resistant finishes, especially at remote facilities. Copper cladding is not acceptable because it is a pollutant source in stormwater.

See section 11.6.2.4 of [DSG Chapter 11, Pump Stations](#) for guidance regarding painting at pump stations.

## 4.5 GENERAL PIPE CONNECTIONS AND SUPPORTS

Pipe connections, supports, and restraints vary significantly by manufacturer, pipe material, and intended function. Care must be used in selecting the correct device for the intended use. Consider consulting a licensed mechanical engineer for design of critical or vulnerable components. Design of pipeline connections and restraints for buried pipe is addressed in [DSG Chapter 5, Water Infrastructure](#) and [DSG Chapter 8, Wastewater and Drainage Infrastructure](#).

### 4.5.1 Facility Piping Connections

Table 4-1 lists piping connection types commonly used by SPU and their typical uses.

**Table 4-1  
Pipe Connection Types and Uses**

Pipe Connection	Typical Uses
Threaded	Joints and connections 4 inches and smaller. Metal only.
Flanged	Joining exposed piping and valves. Does not allow clearance for removal and disassembly or adjustment for misalignment. Do not use in buried applications.
Victaulic coupling	Grooved fittings typically installed to help with disassembly at key locations. Normally used as a dismantling joint when significant adjustability is not required.
Mechanical joint	Joints 4 inches and larger where anticipated deflection is between 2 and 5 degrees.
Compression coupling	Joining two dissimilar materials.
Welded	For rigid connections. Plastics require specialty welds.
Flexible coupling	Absorb deflections from intermittent flows, transient pressures, and ground movements.
Expansion joint	Between rigid points to absorb pipe expansion and contraction due to temperature changes or ground movement.
Dismantling joint	Allows for ease of disassembly. Use where length adjustment is required to remove equipment or mechanical fittings.

Provide joints on either side of valves and equipment that allow for length adjustment and disassembly. SPU recommends using dismantling joints, flange adapters, and grooved couplings in this application. Where practical, process piping should be designed to allow select portions of pipe in each direction to be field cut for final fit up and closure. This greatly reduces the need for precise pipe fabrication and provides contractors with significant flexibility during pipe fitting and assembly.

## 4.5.2 Pipe Supports

All piping installed in vaults, structures, above grade, or in other unburied applications must be fully supported such that the pipe walls and joints are only carrying hydraulic loads. Pipe supports typically take the form of concrete saddles, pipe stands, straps, hangers, or brackets that support the process pipe off the ground or floor, hang it from a wall, or hang it from a ceiling or beam.

Proper support design is essential to reduce vibration and resonance, prevent damage to connected equipment, simplify maintenance, and sagging that could bind joints, valves and other appurtenances.

Figure 4-2 and Figure 4-3 shows typical details for common pipe supports.

Figure 4-2  
Typical Details of Pipe Supports I

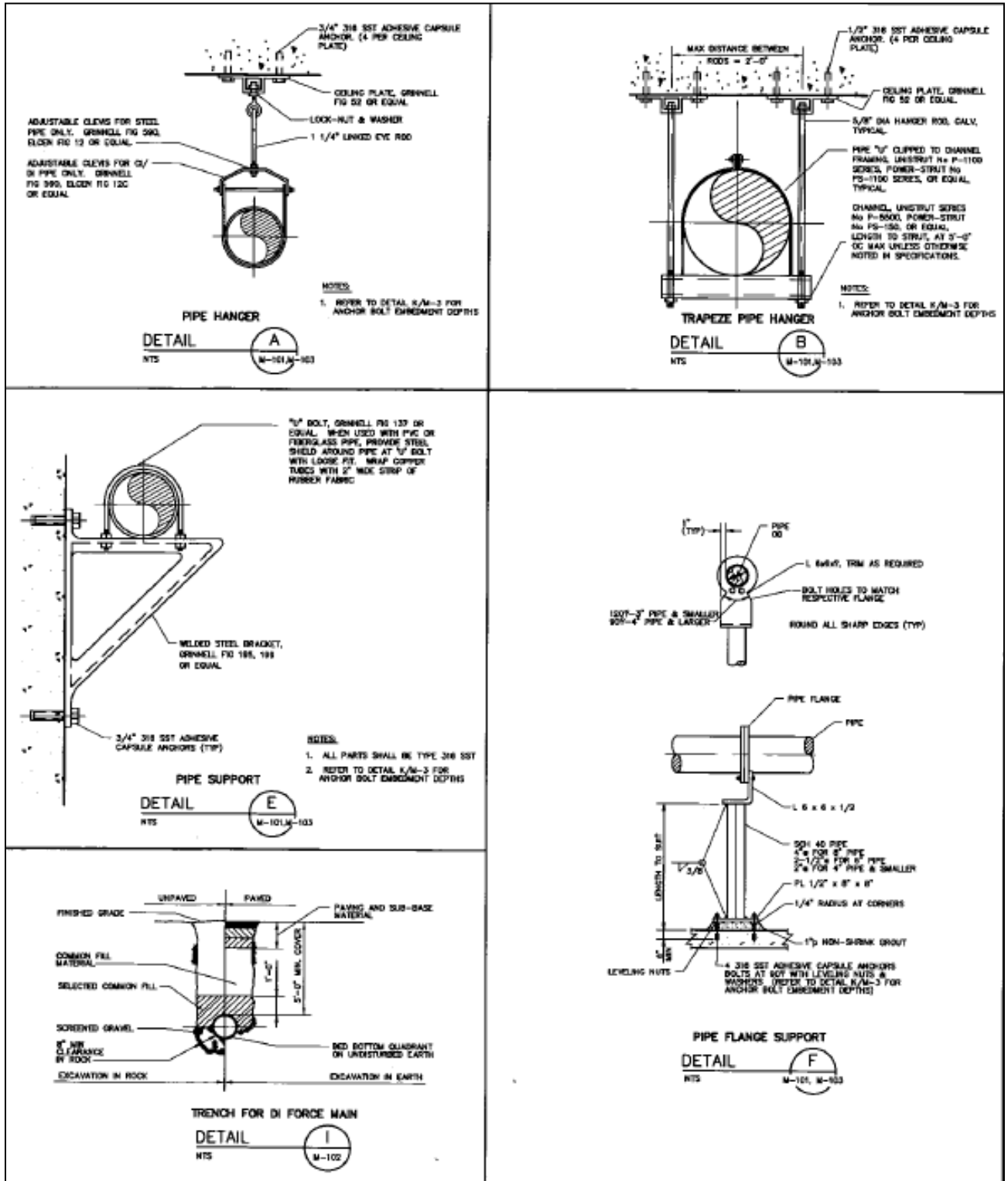
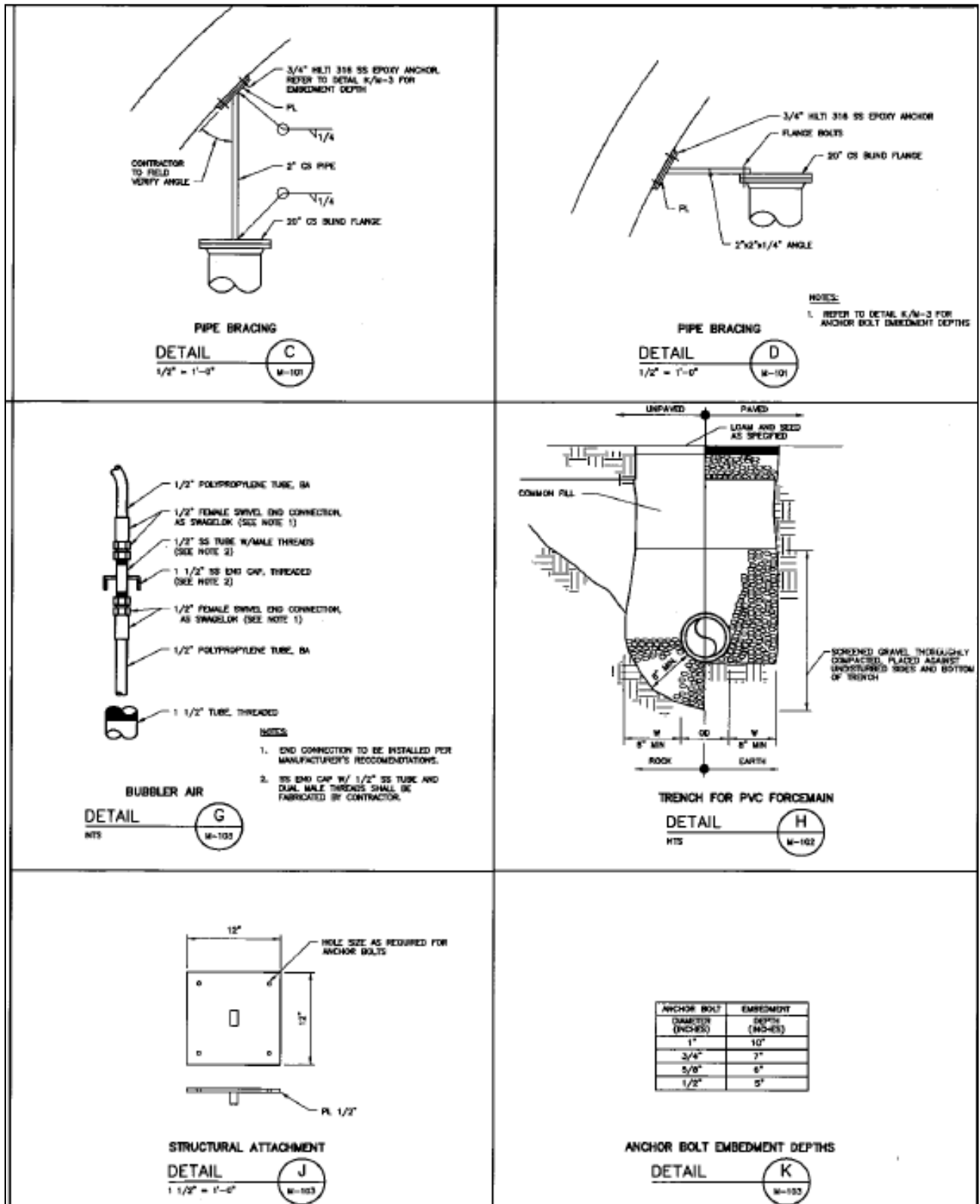

Figure 4-3  
Typical Details of Pipe Supports 2



Pipe supports also should be located adjacent to items with concentrated loads on the piping system, such as pipe bends, and at valves, meters, pump nozzles, and fittings requiring independent support. Properly designed piping support prevents load transfer across these fittings and allows them to be readily disassembled. Pipe loadings should never be transferred to pump nozzles.

Pipe support spacing is a function of pipe material, diameter, wall thickness, pipe deflection limit, vibration control, and fluid load (liquid or gas in the pipe). Support spacing should never exceed the pipe manufacturer's recommended spacing for the pipe and specified load. All pipe supports must be designed for seismic loads.

## 4.6 EQUIPMENT ANCHORAGE

---

Typically, equipment will be rigidly anchored to metal base plates mounted on concrete equipment pads (also referred to as equipment bases). Pads must be designed to carry the fully loaded weight of equipment, including fluids such as fuel and water. Independent pads placed on the ground must consider stability and allowable ground reactions.

Equipment pads should be a minimum of 6 inches above ground elevation or a minimum of 4 inches above a concrete floor. If leveling grout is needed, SPU will review the plan for leveling to ensure contact for the entire surface and to ensure that voids are filled with grout after removal of leveling equipment.

Anchorage requirements must consider all potential loads created by, or experienced by, the equipment, including static, hydrostatic, dynamic, seismic, and wind. Equipment manufacturers can provide some criteria, such as operational dynamic loads. Anchorages must be able to safely absorb and withstand equipment thrust from shut off, start up, and possible pressure surge (water hammer) loads. Construction should include testing for leveling, vibration, and thrust. For rotating equipment adequate mass of the foundation should be considered.

**Tips:** *Work with geotechnical engineers to determine soil bearing and risks of settling. The equipment pad may need to be larger in poor soils, or soils may need amendment to support the pad.*

*Add a requirement to the contract for a layout template; for more complex equipment layouts, the drawings should include conduit detailing. Equipment pads that include more than three conduit runs, or that have specific requirements on the conduit location, are considered more complex. A layout template for reinforcement, conduits, and studs can be useful. Studs set in concrete should also be installed from a template made for or from the actual piece of equipment to be installed.*

*When determining locations for new equipment pads, understand what may be located where the pad will be placed. For example, if there is a watermain adjacent to the pad, ensure that there is not a block for the main that extends into the pad. Modifying equipment bases (i.e., pads) during construction can have long term consequences.*

## 4.7 UTILITY SERVICES AT SPU FACILITIES

---

Facilities often require one or more utility services (electrical, water, sewer, natural gas, or communications). The availability and capacity of existing utilities must be investigated and compared with the estimated demands of the new, permanent facility. See section 11.6.2.10 of [DSG Chapter 11, Pump Stations](#) for guidance regarding utility services at pump stations.

*Tip: During preliminary engineering, work within a minimum and maximum demand for needed power, fire flow, and drainage. Expansion of a project to bring in water, power, or drainage is common and can result from relatively small changes in demand of the utility.*

### 4.7.1 Power

The presence of power lines at or near the site does not guarantee that ample electrical capacity will be available. New services or additional capacity may be required to fulfill site requirements. Identify power needs, at least a range of possible needs and the utilities' requirements during preliminary engineering. If an upgrade of power service is needed, that electrical work can require a major project expansion. See section 9.2.3.1 of [DSG Chapter 9, Electrical Design](#).

### 4.7.2 Water and Fire/Hydrant Service

For information on obtaining a new water or fire/hydrant service, see [SPU's Forms and Resources](#).

### 4.7.3 Sewer and Drainage

For information on permitting new sewer and drainage services for a project on a parcel, see [Side Sewer Permits](#). For new facilities in the City ROW, sewer and drainage service can be reviewed through SPU's internal review processes, but design must conform with the design requirements of SPU's Side Sewer Code (Seattle Municipal Code 21.16).

### 4.7.4 Communications/Telephone

Discuss needs for telephone or lines with SCADA staff.

## 4.8 PIPELINE AND CONDUIT CORRIDORS AT SPU FACILITIES

---

Corridors for pipelines and conduits within a facility must be identified on the site layout by 30% design. The following are SPU's guidelines for laying out the pipeline corridors:

- Pipes and conduits should not be under buildings, except for entering and exiting a building.
- Pipes should be located away from building footings and outside of the footing influence zone, which extends down and out from the edge of the footing at a 45-degree angle.
- Separate handholes should be included for power, SCADA, and security conduits.

See section 11.6.1.6 of [DSG Chapter 11, Pump Stations](#) and section 10.5.3.3 of [DSG Chapter 10, I&C \(SCADA\)](#) for guidance on pipeline corridors for pump stations and instrumentation and control, respectively.

## 4.9 TEMPERATURE AND VENTILATION REQUIREMENTS

---

Buildings and some equipment should be maintained between 50° F and 90° F to prevent damage to equipment and process lines due to freezing or overheating. Adequate heating to control issues such as condensation on walls and pipes, and dripping valve packing can help prevent corrosion and damage to equipment. Ambient heating can be supplemented by using heat tracing, while cooling can be supplemented by increased ventilation and air exchanges and use of a heat pump if temperature is expected to be a concern.

The design engineer should identify temperature and ventilation requirements during preliminary engineering since these design elements typically require a mechanical engineer. See section 10.8.1.2 of [DSG Chapter 10, I&C \(SCADA\)](#) for guidance on environmental requirements for instrumentation and control equipment.

### 4.9.1 Ventilation

Heating, ventilation, and air conditioning (HVAC) systems are typically designed for occupied buildings or for equipment protection according to ASHRAE and other related industry standards. Ventilation requirements per NFPA 820 may also apply depending on the desired electrical hazard classification for the space.

The number of air changes required depends on the location and desired use. Generally, a separate ventilation system should be employed for each enclosed building area. Areas that share a common environment (connected ductwork or normally closed doors and hatches) must be treated as single common areas and carry the most stringent of the area classifications. For pump station HVAC requirements, see section 11.6.2.1 of [DSG Chapter 11, Pump Stations](#).

#### 4.9.1.1 Insect and Pest Screening

Screening is required for all ventilation openings to prevent ingress of birds, animals, and insects. Typically, two levels of mesh are required – heavy duty mesh (1/4" or smaller openings) for animals and fine mesh (1/16") for insects. Mesh screening for insects is also required for all louvers on equipment and electrical cabinets.

## 4.10 LANDSCAPING AND IRRIGATION

---

During design of a landscape and irrigation system, consider the installation, maintenance, and management phases to minimize impact to resources. The design engineer must consult with landscape maintenance staff during the landscape design process.

For work within the City ROW, consult with SDOT Urban Forestry. For projects in or adjacent to City parks and boulevards, see Seattle Parks and Recreation Standards. For natural areas not on

Seattle Parks and Recreation property, consult [Green Seattle Partnership Specifications](#). On SPU property, use the principles of [Crime Prevention Through Environmental Design](#) (see section 15.5.1 of [DSG Chapter 15, Physical Security](#)) to avoid security threats and hiding places, use native plants for new plantings ([King County Native Plant Guide](#)), and work to control invasive plants ([King County Noxious Weed Guide](#)).

Check on-site requirements in the Stormwater Manual, Green Factor, and Environmentally Critical Area (ECA) code requirements for the project. At a minimum, drawings should identify all landscaped areas to include vegetation types (turf, groundcover, shrub, tree), planting palette for each vegetation type, recommended spacing and quantity for each plant species, and notes and/or requirements for each plant species. In addition, drawings should delineate areas and define materials and methods for erosion control (e.g., coir logs, geotextile, wattles) and soil amendments (e.g., compost, clean-green arborist’s mulch). Best efforts should be made to install plants from the Puget Lowlands seed zone.

**Tip:** *Consult early about the landscaped area and availability of water. For consultation on any landscape or restoration element from options analysis through design, contact SPU’s Landscape Asset Program Manager [Removed for Security](#). This will help SPU determine what landscape, plant selection, weed control, amendments, and erosion control measures may be appropriate for the site or whether to install a full irrigation system, install a hose bib, or to define a plan for watering by truck. This will help determine when the project team will need to include an ecological restoration or landscape design consultant and the scope of their work.*

### 4.10.1 Landscape Design

The following are SPU’s general guidelines for landscape design:

- Minimize ground disturbance and protect existing soil and vegetation where possible and identify protected areas on the drawings per [Standard Specifications and Plans - Utilities I](#) section 8-01.3(2)B. Work to protect the native soil profile as much as possible.
- When ground disturbance is unavoidable, work to restore the native soil profile from bottom to top. Add compost and then “clean (weed free), green (nitrogen rich – including leaves and needles)” arborist wood chip mulch amendment as the last step for soil restoration.
- Restore soils disturbed by construction with compost amendment per [Standard Plan and Plans - Utilities I](#) 142.
- Select native plant species that: are appropriate for the urban ecosystem landscape setting and adjacent neighborhood; have proven success in the type of soil and conditions present; and are relatively low maintenance.
- For above-ground built assets (e.g., piping, venting, other drainage features), the design engineer must determine, based on the site specifics, how close vegetation should be to the built asset. Considerations include fish, bird, and wildlife habitat, risks to built assets, and adjacent property.
- When identifying trees for preservation during construction and selecting trees for installation in the City ROW, consult with SPU’s and SDOT’s staff arborists.
- Add a bid item to require a Tree, Vegetation, and Soil Protection Plan (TVSPP). See [Standard Specifications and Plans – Utilities I](#) section 8-01.3(2)B.

The following are SPU's design considerations for weed and pest control:

- Choose native plants and design planting plans that are low maintenance and foster an area free of invasive species and weeds.
- Control invasive plants weeds by the following methods, in order of preference:
  - Appropriate plant choice and spacing for the site
  - Mechanical methods
  - Chemical methods, that are only used when other methods do not work.
- The City prefers mechanical control and suppression of undesired vegetation. Pesticides may not be used without express consent from the SPU Landscape Asset Program Manager.

### 4.10.2 Landscape Plan

A final landscape plan must be signed by a licensed landscape architect prior to submittal for approval.

Plans must identify all landscaped areas, including vegetation types (turf, groundcover, shrubs, and trees), planting palette for each vegetation types, recommended spacing and quantity for each plant species, and notes and/or requirements for each plant species. In addition, drawings should delineate areas and define materials and methods for erosion control (e.g., coir logs, geotextile, wattles) and soil amendments (e.g., compost, clean-green arborist's mulch). Best efforts should be made to install plants from the Puget Lowlands seed zone.

Landscape plans must show:

- The name, size, quantity, location, and water use need of each plant.
- Soil amendment and mulch type, depth, and location.

Depending on the site area, designers should work to have a uniform hydrozone for all of the plants considered, for ease of maintenance and watering. If unavoidable, minimize the different hydrozone needs of selected plants and group plants within similar hydrozones.

#### 4.10.2.1 Plant Material

The following are SPU's design considerations for plant materials:

- Plant material should be selected based on low resource and maintenance needs: "Right plant, right place." Refer to [Choosing the Right Plants for Your Site](#).
- Look for hardy plants that are native and drought-tolerant. Choose plants that can handle hotter and drier conditions from late spring to fall per climate change forecasts for the Puget Sound.
- Consider plants that are native and/or adapted to neighboring hotter and drier ecoregions, such as west side of the Cascades, Oregon, and Northern California.
- Plants should be located to meet their short and long-term cultural needs.
- Plant material should be selected for the appropriate hydrozone.

#### 4.10.2.2 Turf

The design should minimize mowing and maintenance requirements. When possible, avoid using turf in places where SPU is responsible for landscape maintenance. Turf should only be considered for recreational or play areas and for places where people are encouraged to frequent. Where turf is needed, consider seeding with native fescues and rye grasses, per recommendations from [University of Washington's Center of Urban Horticulture](#).

The landscape designer must ensure that no turf area is smaller than 12 ft by 12 ft.

#### 4.10.2.3 Soil

The landscape plan must meet all topsoil and soil amendment requirements defined in [Standard Specifications and Plans – Utilities I](#) section 8-02.3(2).

### 4.10.3 Irrigation Plan

Choosing new landscape designs that do not require long-term irrigation is an important part of SPU's climate preparedness strategy. Even for sites that need a full irrigation system initially, the goal should be to phase out use of these systems after the third year of installation of new plants.

Early coordination with SPU Operations, including SPU Grounds Crew Supervisors, and the SPU Landscape Asset Program Manager is required when selecting a water option. Options to consider include no need for irrigation due to the proximity to surface or groundwater (e.g., wetland or riparian areas); transported water; a water supply with hose bib; or a full irrigation system.

If a hose bib or full irrigation system is selected, ensure that the drawings specify the location of the water meter service, which will be under a separate permit. Typically, as the owner, SPU will order the new water service. The Project Manual defines the process for water service coordination.

A backflow prevention assembly (with its annual inspection requirement) is required between any irrigation system and the water meter. See [Standard Specifications and Plans – Utilities I](#) section 9-30.16, which notes that a double-check valve assembly may be installed below ground, but only in an approved enclosure.

When SPU chooses a full irrigation system, irrigation design must be done by an Irrigation Association Certified Irrigation Designer (CID) with a commercial specialty. Irrigation systems must be designed to current industry best practices for water conservation. For additional information, refer to [SPU's Water Efficiency Tips](#). Where appropriate, consider automated drip systems as the most water efficient system for designed landscapes.

The designer is responsible for verifying the actual flow and pressure at the site to design an irrigation system appropriate for the site. See [Standard Specifications and Plans – Utilities I](#) section 8-03 for irrigation system requirements.

## 4.1.1 CASING PIPE

---

This section describes common design considerations for casing pipe for water, sewer, and drainage. Pipelines may be installed in a casing for several reasons, including:

- Crossing rails, including heavy, light rail, and street cars.
- Crossing major arterials and highways.
- Water crossings.
- Shallow depth of cover with heavy traffic to provide structural integrity to protect carrier pipe.
- Access to the carrier pipe for future maintenance and replacement for various reasons:
  - Built over
  - To add tiebacks around the pipe
  - To avoid future surface disruption, such as within an easement or non-standard or expensive surfaces
- Lack of adequate separation between watermain and sewer line per Washington Department of Health requirements (a casing pipe may be used to mitigate the situation).

### 4.1.1.1 Casing Pipe Material

The standard casing pipe material is bare or coated steel, especially for a jacked casing installation. See [Standard Specifications and Plans – Utilities I](#) section 7-11.3(7)C.

Thick wall PVC C900, C905 DR 14, ductile iron, polypropylene, polyethylene, or concrete may be used as casing for trench installation if it can support the loading without causing deflection that can affect the spacers or carrier pipe, which can make future maintenance and removal more difficult.

### 4.1.1.2 Minimum Casing Diameter

The casing diameter must be sized to provide a minimum of 4 inches between the inside of the casing and the largest outside diameter of the carrier pipe, including the pipe bells and joints. This allows for potential deflection of the casing pipe and installation of the casing spacers. The sizing must accommodate slope (especially for sewer or drainage pipe), fittings, and slight bends/adjustment needs).

**Tip:** *Provide elevation information on the carrier pipe and let the Contractor establish elevations for any casing. This is likely opportunity for error due to design changes, field changes, or specific requirements for the casing and spacers selected by the Contractor.*

### 4.1.1.3 Minimum Casing Thickness

The engineer of record should confirm the adequacy of the casing pipe structural capacity in each specific application. For jacked casing pipes, the earth loading should be calculated for the pit locations and selection of a minimum casing thickness. However, the Contractor's jacking equipment will often determine the actual required thickness.

Table 4-2 lists the minimum steel casing wall thickness for under roads, highways, and rails for between 4.5 ft and 20 ft of cover.

**Table 4-2**  
**Minimum Steel Casing Pipe Thickness for Road and Highway and Rail Applications<sup>1-4</sup>**

Nominal Diameter (Inches)	Wall Thickness (Under Road)	Wall Thickness (Under Rail Tracks)
6 thru 14	0.25	0.25
16	0.25	0.375
18	0.313	0.375
20	0.313	0.375
22	0.313	0.375
24	0.313	0.375
26	0.313	0.5
28	0.375	0.5
30	0.375	0.5
32	0.375	0.625
34	0.375	0.625
36	0.375	0.625
38	0.375	0.625
40	0.375	0.625
42	0.375	0.625
44	0.375	0.75
46	0.375	0.75
48	0.375	0.75
50		0.75
52		0.75
54		0.875
56		0.875
58		0.875
60		0.875
62		0.875
64		0.9375
66		0.9375
68		0.9375
70		1.0
72		1.0

## Notes

<sup>1</sup> Adopted from Iowa Department of Transportation Design Manual and modified for standard steel pipe thickness standards.

<sup>2</sup> Minimum thicknesses assume a minimum of 4.5 ft of cover over the top.

<sup>3</sup> Casing with depths of over 20 ft must be designed for the specific location and loading conditions. If site conditions limit depth of cover, perform design calculations to determine minimum thickness of the casing, with a limit on deflection that permits the carrier pipe bells and casing spacers to function normally.

<sup>4</sup> The railroad values are based upon American Railway Engineering and Maintenance-of-Way Association design standards. Individual railroad standards may vary.

### 4.11.4 Installation Considerations for Future Access and Carrier Pipe Replacement

One of the primary reasons for installing casings is for easier removal of carrier pipe and to reinstall a replacement carrier pipe without disrupting traffic or requiring disruption of rail tracks, which will be very expensive in the future.

The design engineer must always think about the engineers, utility crews, and contractors that must work on future installations and maintenance. Toward these ends, design engineers should consider:

- Adequate spacing at the ends of the casing pipe to accommodate future pipe replacement.
- The jacking pit for future access must be wide enough to provide adequate working room and long enough to accommodate a 20-ft stick of pipe in addition to space for jacking and shoring. Consider acquiring permanent easement rights.
- Casings with depths of over 20 ft must be designed for the specific location. If the casing is installed using trenching, the trench bedding and compaction must follow the same specifications as the water pipe, transmission, or sewer pipe standards. That is, [Standard Specifications and Plans – Utilities I](#) 350 for watermain trench and bedding or Class B per [Standard Specifications and Plans – Utilities I](#) section 7-17.3(1)B for sewers.

### 4.11.5 Spacers and End Seals

Always install casing end seals to prevent groundwater from moving through the casing, which can potentially increase the corrosion rate of the casing and carrier pipe. See [Standard Specifications and Plans – Utilities I](#) section 7-11.3(7)C.

Do not grout the annular space between the casing and the carrier pipe, which would make future work for maintenance and repair more difficult.

### 4.11.6 Cathodic Protection

If the carrier pipe and casing are in an area with corrosive soil, near electrified rail systems, or near other utilities with an active corrosion protection system; the carrier pipe and casing can be protected using bonded coatings, and linings, passive (anode) or active cathodic protection systems.

See [DSG Chapter 6, Cathodic Protection](#) and consult a corrosion protection engineer for advice for each location.

## 4.12 RESOURCES AND LINKS FOR STORMWATER CODE COMPLIANCE

Information on meeting stormwater code requirements and related City standards are provided throughout the City's website. The tables in this section provide links to some of those locations. The most comprehensive source, and the best place to start, is the SDCI Stormwater Code website at the top of Table 4-3.

**Tip:** *Many SPU projects have potential impacts far beyond the immediate surface area planned for construction. Look at the surrounding topography to identify stormwater impacts and solutions as an integral piece of the project definition and scoping.*

### 4.12.1 Determine Project Minimum Requirements

While scoping a project, it is important to determine the stormwater code requirements. Refer to Volume 1: Project Minimum Requirements of the Stormwater Manual. When a project is located within the City ROW, see ROW Flowcharts 1 through 4.

**Table 4-3**  
**Links to General Stormwater Code Information**

Document/ Topic Link	Description
<a href="#">Stormwater Code and Manual</a>	SDCI website with links to code, stormwater manual and related information
Flow Control and Treatment Guidance in <a href="#">DSG Chapter 8, Drainage and Wastewater Infrastructure</a>	DSG Chapter 8, sections 8.7.8 Water Quality Treatment and 8.7.10 Green Stormwater Infrastructure.
<a href="#">SPU Public Drainage System Requirements DR</a>	SPU Public Drainage System Requirements Director's Rule (SPU DWVW-210) includes Storm Mainline Extension, Approved Point of Discharge, and Ensuring Sufficient Capacity Requirements as well as the Public Drainage System Design Requirements that were in SPU CAM 1180. This rule replaces SDCI's Small Project Point of Discharge protocol and prohibits any new drainage discharges to the "formerly combined" public sanitary sewers and requires mainline extensions for certain projects in the combined sewer and ditch and culvert areas.
<a href="#">Side Sewer Code and Director's Rules</a>	SDCI website with links to side sewer code and related information
<a href="#">Appendix F - Hydrologic Analysis and Design</a>	General hydrologic modeling guidance to meet the requirements of the Stormwater Code.

#### Acronyms and Abbreviations

ROW: right of way

SDCI: Seattle Department of Construction & Inspections

Removed for Security

Removed for Security

All SPU capital improvement projects should plan for City stormwater code review by the Standards and Plan Review Section. Initial review should be of a 30% draft drainage report. The drainage report should also be reviewed at 60%, 90%, and final. This review does not typically include review of the conceptual Construction Stormwater and Erosion Control (CSEC) plan.

**Tip:** Consider structuring your drainage report to explain how the project meets the minimum requirements for all projects summarized in Volume 1, Chapter 3 of the Stormwater Manual. It is common to focus on questions about flow control and water quality requirements and thus miss a requirement (for example, ensuring sufficient capacity or protect wetland) with a bigger impact on the project.

Requirements are more complicated for parcel-based projects within the City and are tied to building permits issued by SDCl. Allow extra time to work through code requirements and consult early with SDCl.

For projects outside the City limits, see [DSG Chapter 2, Design for Permitting and Environmental Review](#).

## 4.12.2 Construction Stormwater and Erosion Control

Refer to [DSG Chapter 3, Design for Construction](#) for details regarding CSEC. Additional links and references are provided in Table 4-4.

**Table 4-4**  
**Links with Information on CSEC**

Document/Topic Link	Description
<a href="#">DSG Chapter 3, Design for Construction</a>	DSG Section 3.7 Construction Stormwater and Pollution Prevention in <a href="#">DSG Chapter 3, Design for Construction</a>
<a href="#">Ecology Permit Information</a>	Ecology website Construction Stormwater General Permit for projects with one acre or more of disturbed surface
<a href="#">Volume 2: Construction Stormwater Control</a>	Stormwater Manual volume includes Chapter 3 on selecting construction stormwater controls, including checklists and Chapter 4 describing BMPs
<a href="#">Standard Specifications</a>	Refer to Specification sections I-05.13(3), I-07.15, I-07.16(2) and 8-01
<a href="#">Appendix I8B – Temporary Discharges</a>	DSG Appendix I8B Temporary Discharges of <a href="#">DSG Chapter 18, Development Services</a>
<a href="#">King County Construction Dewatering</a>	King County’s website on construction dewatering, administered under its Industrial Waste Program.

Acronyms and Abbreviations  
 BMPs: best management practices  
 CSEC: construction stormwater and erosion control

Removed for Security

### 4.12.3 On-Site Stormwater Management

The terms “low-impact development” and “green stormwater infrastructure” are also used to refer to the same general best management practices using dispersion, infiltration, and retention described as “on-site stormwater management” within the stormwater code and manual. Refer to Volume 3: Project Stormwater Control of the Stormwater Manual. This and additional links are provided in Table 4-5.

The Stormwater Manual allows two methods for demonstrating compliance. Use the on-site list and list approach calculator if best management practices (BMPs) for flow control or water quality are not included in the design of the project.

**Table 4-5**  
**Links with Information for Design of On-Site Stormwater Management (GSI)**

Document/ Topic Link	Description
<a href="#">Volume 3: Project Stormwater Control</a>	Stormwater Manual volume includes Chapters 3 on selecting BMPs and requirements for determining infiltration feasibility. Chapter 5 describes BMP design
<a href="#">Rain Gardens for Sidewalk Runoff</a>	CAM 1190 Rain Gardens for On-Site Stormwater Management of Sidewalk Runoff
<a href="#">SDCI Forms and Documents</a>	Part of the SDCI Stormwater Code website includes the List Approach Calculator (under Forms and Documents). Reference materials include SPU Allowable Permeable Pavement Wearing Course Materials.
<a href="#">DSG Chapter 3, Design for Construction</a>	DSG Section 3.15 Geotechnical Services. Also see 3.19.4 Bioretention and biofiltration in <a href="#">DSG Chapter 3, Design for Construction</a>
<a href="#">Appendix D – Subsurface Investigation and Infiltration Testing for Infiltrating BMP's</a>	Guidance on subsurface testing and reporting to meet the requirements of the Stormwater Code.
<a href="#">Appendix 8C – GSI Manual</a>	Volume 3 on the design phase of the Green Stormwater Infrastructure Manual for Seattle. The manual was jointly developed for capital improvement projects by SPU and King County.
<a href="#">Streets Illustrated 3.4 Drainage</a>	Guidance on use of on-site stormwater management BMPs in Seattle Streets.
<a href="#">Streets Illustrated Clearances and Setbacks</a>	Describes required clearances from on-site stormwater management BMPs from utilities and street features.
<a href="#">Green Stormwater Infrastructure</a>	SPU web site on green stormwater infrastructure, includes links to current and completed GSI projects.
<a href="#">Appendix 7H – GSI Modeling Methods</a>	DSG Green Stormwater Infrastructure Modeling Methods
<a href="#">Standard Specifications</a>	See Section 5-06 Pervious Cement Concrete Pavement and 7-21 Bioretention.
<a href="#">Standard Plans</a>	See Standard Plans 291 through 299, 403 and 425.

#### Acronyms and Abbreviations

BMPs: best management practices  
CAM: Client Assistance Memorandum  
GSI: Green Stormwater Infrastructure

**Tip:** *Infiltration testing required by the stormwater code can complicate the scope and schedule of a project. There are also specific requirements for locating tests close to any infiltrating BMP and reporting results. For advice on scope and schedule, consult with SPU’s Geotechnical Engineering Section.*

## 4.13 RESTORATION OF DISTURBED AREAS

---

See section 3.17 of [DSG Chapter 3, Design for Construction](#) for details on restoration of disturbed areas.

## 4.14 SIGNS AT SPU FACILITIES

---

Facilities will typically have two types of signage visible on the outside of the facility: facility identification signage and public safety signage. Signage should be designed in accordance with Seattle’s Sign Code (Seattle Land Use Code Ch. 23.55). Signs can be specified in the contract drawings or supplied by SPU Operations.

Facility identification signage should contain basic information on the facility, facility name, identification number, type of facility (potable water supply, wastewater/sanitary, or stormwater facility), owner (SPU), and contact information for general inquiries and emergencies.

Public safety signage warns the public of potential hazards that exist at a facility or site. Hazards include chemicals stored on-site, wastewater, high voltage, relief valve discharge, and more. Public safety signs are to be placed in clear view in an easily accessible location without having to enter the property. If a facility is entirely in the public ROW, proposed signage should be placed as near to the facility as possible and may have to be mounted to nearby fencing or a free-standing post outside of vehicle and pedestrian areas. Sign placement in the ROW must be permitted by SDOT. All warning signs must be in accordance with industry standards (National Electrical Code [NEC]), Occupational Safety and Health Administration [OSHA], and Institute of Electrical and Electronics Engineers [IEEE]), and other applicable regulatory items.

## 4.15 GEOTECHNICAL SERVICES

---

See section 3.15 [DSG Chapter 3, Design for Construction](#) for SPU guidance on geotechnical services.

## 4.16 FUTURE EXPANSION CONSIDERATIONS

---

During preliminary design, an estimate of future expansion needs for the facility should be identified. Future expansion may include installation of the following:

- Permanent backup power supply
- Additional equipment
- Additional storage capacity
- Maintenance and storage facilities
- Parking

Facility layout should be made as if the future conditions were included now. Locations should be clearly identified on the drawings. Examples of future facility configuration include the following:

- Construction of the expansion should not significantly disrupt ongoing operations at the facility.
- Equipment, electrical and instrumentation should allow new equipment to be added while the existing equipment remains in service.

Currently, SPU does not have a standard for storing design information for a future condition. Therefore, project teams should document any future considerations in the basis of design plan sheet and project files.

## 4.17 RESOURCES

---

Removed for Security

