

PLAN VIEW

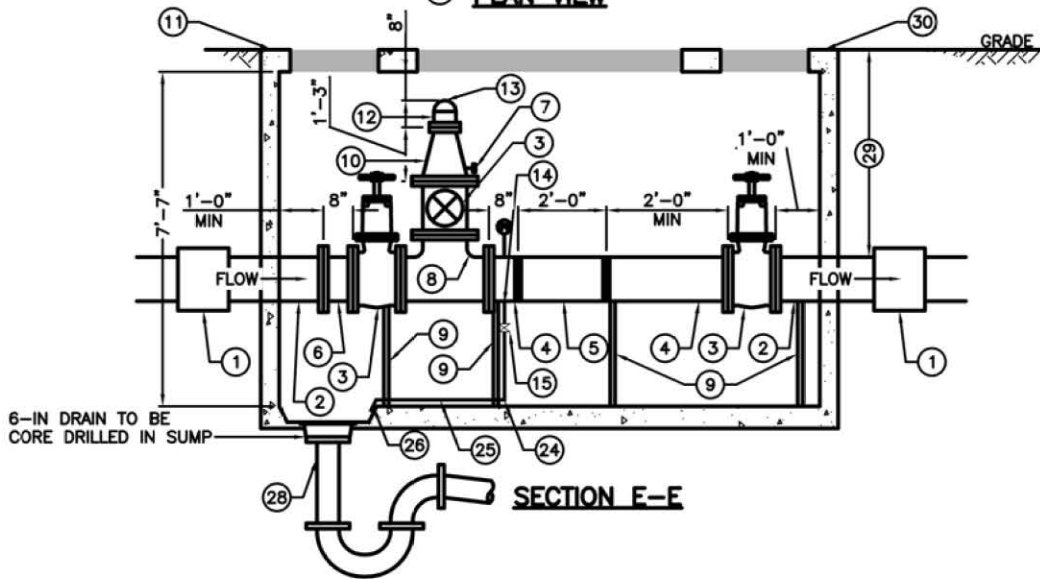

SECTION E-E

KEY NOTES:
SYMBOL NOTE

- ① 12" CI TO DI INSULATED PIPE COUPLER
- ② 12" DI SPOOL (FLANGED x PE)
- ③ 12" FLANGED GATE VALVE WITH HANDWHEEL
- ④ 12" DI SPOOL (FLANGED x GRV)
- ⑤ 12" DI SPOOL (GRV) FOR PIG LAUNCH AND ACCESS. MINIMUM 24 INCH SPOOL LENGTH.
- ⑥ 12" DI DISMANTLING JOINT (FLANGED x FLANGED)
- ⑦ 3/4" CORP STOP AND BALL VALVE
- ⑧ 12"x12" DI TEE (FLANGED)
- ⑨ PIPE SUPPORT
- ⑩ 12"x6" DI REDUCER (FLANGED)
- ⑪ OLDCASTLE 33-712-LA PRECAST CONCRETE VAULT OR APPROVED EQUAL
- ⑫ 6" MALE DI CAMLOCK FITTING (CAMLOCK x FLANGE)
- ⑬ 6" FEMALE DI CAMLOCK DUST CAP
- ⑭ 2" 304SS DRAIN
- ⑮ 2" FLANGED BALL VALVE
- ⑯ FABRICATED GALVANIZED STEEL FIXED LADDER WITH TELESCOPING SAFETY POST AND FABRICATED STEEL RUNGS WITH SAFETY TREAD
- ⑰ BILCO SINGLE LEAF 2' X 2' ACCESS HATCH
- ⑱ BILCO DOUBLE LEAF 4' X 6' ACCESS HATCH
- ⑲ 24" KOR-N-SEAL OR APPROVED EQUAL
- ⑳ 16" KOR-N-SEAL OR APPROVED EQUAL

- ㉑ ANNULAR SPACES BETWEEN PIPE AND FLEXIBLE MAINTENANCE HOLE CONNECTOR SHALL BE FILLED WITH A PRODUCT APPROVED BY THE MAINTENANCE HOLE MANUFACTURER THAT IS RATED FOR A SEWAGE ENVIRONMENT.
- ㉒ HATCH SHALL BE FURNISHED WITH A PERIMETER FRAME DRAIN. PERIMETER FRAME DRAIN SHALL BE ROUTED TO VAULT DRAIN IN A WAY THAT DOES NOT CREATE OBSTRUCTION TO WORK IN VAULT.
- ㉓ LATERAL PIPE SUPPORT
- ㉔ 2-INCH 304 SS 90 DEG EL FLANGED
- ㉕ 2-INCH 304 SS FLANGED PIPING (TYP)
- ㉖ 2-INCH 304 SS 45 DEG EL FLG X PE PIPE MAY NOT ENTER MAINTENANCE HOLE THROUGH CONE SECTION OR JOINT.
- ㉗ P-TRAP PER DETAIL 3/#####
- ㉘ DEPTH TO TOP OF EXISTING FORCEMAIN PIPE WAS ESTIMATED BASED ON AS-BUILT DRAWINGS. DEPTH TO PIPE AT PROPOSED VAULT LOCATION SHALL BE POSITIVELY VERIFIED BY POTHOLING BY CONTRACTOR AND CONFIRMED WITH ENGINEER PRIOR TO ORDERING PIPING, FITTINGS, EQUIPMENT, VAULT, OR HATCHES. FIELD CONDITIONS MAY VARY AND VAULT PIPING LAYOUT WILL BE MODIFIED BY ENGINEER AS NECESSARY TO MAINTAIN CLEARANCE BETWEEN PIPE FITTINGS AND BOTTOM OF VAULT LIDS.
- ㉙ TOP OF VAULT AND VAULT HATCHES SHALL BE AT GRADE AND BE TRAFFIC RATED.