

SPECIFICATION SECTION 01 35 05

SEWER BYPASS PLAN

PART 1 - GENERAL

1.01 SUMMARY

- A. Section Includes:
 - 1. Temporary Sewer Bypass Systems.
- B. **Section 01 35 05A** at the end of this Section contains additional guidance on pump locations, discharge locations, existing system curves, pipe routing, critical overflow locations, and equipment staging areas. This Section, Section 01 35 05A, and the Drawings define the minimum expectations for performance of the Contractor's bypass systems.
- C. Related Sections include but are not necessarily limited to:
 - 1. Division 00 - Procurement and Contracting Requirements
 - 2. Division 01 - General Requirements
 - 3. Section 01 57 13 – Construction Stormwater Pollution Prevention
 - 4. Section 01 57 50 – Temporary Environmental Pollution Control

1.02 REFERENCES

- A. This Section incorporates by reference the latest revisions of the following documents. In case of conflict between the requirements of this Section and the listed documents, the requirements of the Contract Specifications will prevail.
 - 1. 2023 Edition of the City of Seattle Standard Specifications for Road, Bridge, and Municipal Construction

1.03 SCOPE OF WORK

- A. Construct and operate a temporary sewer bypass system meeting the requirements of this Section.
- B. Following project commissioning, remove temporary pumping equipment and restore any temporary modifications to structures.

1.04 SUBMITTALS

- A. See **Section 01 33 10 - Submittals** for requirements for the submittal process.
- B. Detailed Sewer Bypass Plan (Plan) for bypass of wastewater.
 - 1. Submittal to Engineer allowing at least 10 Working Days for review and return of comments.
 - 2. Plan must be prepared and sealed by a Professional Engineer licensed in the State of Washington.
 - 3. Plan must be fully compliant with City of Seattle Standard Specifications for Road, Bridge, and Municipal Construction **Sections 7-17.3(2)I and 1-07.5(2)**, except as modified by this Section.

4. Plan must include, at a minimum, the following:
 - a. Schematic design of bypass systems, including pipe and equipment layout, all relevant elevations, pump sizes, capacities, and power requirements.
 - b. Engineering calculations showing that the proposed systems will meet the requirements of this Section under all operational conditions and wastewater levels.
 - c. Description of sewer plugging method and materials, including description of physical location in sewer where flow will be plugged.
 - d. Means of preventing back-up of wastewater to construction area from bypass discharge location.
 - e. Source of temporary SCL power with backup generator and automatic means of transfer, one-line diagram, panel schedule, and load calculations.
 - f. Detailed bypass monitoring and response plan that will ensure operations are compliant with the provisions specified herein. Minimum requirements for the monitoring and response plan are shown in **Article 3** of this Section.
 - g. Method and equipment for providing ventilation of work area that will ensure operations compliant with provisions specified herein.
 - h. Provisions for noise control to achieve the noise requirements shown in this Section.
 - i. Schedule for installation, maintenance, and removal of bypass system.
 - j. Any required Contractor-obtained permits, including Noise Variances, if applicable
- C. If the Contractor elects to use a bypass method that would require use of property outside of the public Right of Way, existing easements, or property rights obtained by the Owner, it is the Contractor's responsibility to arrange all necessary access and additional temporary construction agreements with all affected parties for the location of the bypass pumping system. The Contractor must secure all required written permissions and submit them to the Engineer for approval prior to using any private property, whether adjoining to the Work or not. See **Section 00 72 00 – General Conditions, Paragraph 1.04.X**.
- D. The Engineer's review and approval of the Plan for bypass of wastewater will not relieve the Contractor of its responsibility for any public liability for sewage spills under this Contract.
- E. Flows in any of the sewers where Work will occur may contain sanitary or combined sewage (a mix of sanitary and storm water sewage). Appropriate precautions must be taken for all construction.

PART 2 - PRODUCTS

2.01 BYPASS PUMPING EQUIPMENT

- A. Pumps, controls, sensors, valves, piping and any other bypass system components must be suitable for continual and intermittent automatic operation in the range of flows specified in this Section. All components must be rated for wastewater service.
- B. All pumps must be fully automatic self-priming units that do not require the use of foot-valves or vacuum pumps in the priming system. Pumps which are designated in the submitted Plan to be run continuously must be designated by the pump manufacturer as capable of run-dry operation.
- C. Pumps and generators must be compliant with the noise limits of **Paragraph 3.01.B** of this Section. Pumps not meeting this requirement must be furnished with noise dampening enclosures or other means of noise mitigation, as required to comply with these limits.
- D. Primary pumps must be electrically driven, non-clogging, capable of handling domestic wastewater with 3-inch diameter solids and suspended rags. The Contractor is specifically cautioned that rags are known to be present in the influent to be bypassed and must select temporary pumping equipment accordingly. Standby pumps that do not operate on a regular basis are permitted to be engine-driven. See **Section 26 05 00 – Electrical: Basic Requirements** for existing available power at the Project Site.
- E. An additional standby bypass pumping system with 100 percent redundant pump capacity must be provided by Contractor. The redundant system must be onsite and ready for operation at any time bypassing is underway.
- F. Where both primary and backup systems are electrically driven, provide an interlock to prevent any simultaneous operation of pumps that would exceed maximum power requirements shown in **Article 3.04** of this Section.
- G. Remote monitoring and alarm equipment must be fully automated, and operational 24/7. The equipment must record level and alarm data at 5-minute intervals and have an 'uptime' rating of 95 percent or better. The data must be recorded in a spreadsheet format and made available to the Engineer upon request.

2.02 BACKUP POWER FOR BYPASS PUMPING

- A. Power to the bypass system must remain uninterrupted. Primary and backup power sources are required. Both primary and redundant pumps must be connected to the backup power source.
- B. Where backup power is to be provided with a Contractor furnished portable generator, the Contractor must also furnish an automatic transfer switch (ATS) to control the portable generator in the event of utility power failure.
- C. In lieu of providing a backup generator and ATS, the Contractor may, at their option, provide a separate, automatically started, engine-driven pumping system to satisfy both the redundant pumping system requirement of **Article 2.01**, as well as the backup power requirement of **Article 2.02**.

2.03 PLUGS FOR BLOCKING EXISTING SEWER PIPES

- A. Plugs for blocking existing sewer pipes during bypassing must be suitable for the seating or unseating head between the blocked pipe and local overflow point, plus five feet. Plugs must seat firmly into the blocked pipe creating a watertight seal that cannot be

broken through accidental or unintended impacts. Plugs must have suitable connection points for chains, blocks, or other bracing to prevent unintended movement.

PART 3 - EXECUTION

3.01 SEWER BYPASS OPERATIONAL REQUIREMENTS:

- A. Installation of sewer bypass and any related construction to install bypass must not be performed prior to the Engineer’s review and approval of Bypass Plan submittal.
- B. Bypass pumping requirements are as shown in the table below:

	Site 1	Site 2	Site 3
Diversion location			
Discharge location			
Min. Pump Capacity			
Force Main TDH²			
Max. Pump Power			
Proposed Electrical Service			
Stop Setpoint¹			
Start Setpoint¹			
Alarm Setpoint¹			
Overflow			
Noise Limit			

¹ Setpoints shown are given as depth in feet above invert of the diversion location. The Contractor may propose alternate stop and start setpoints. Start setpoints must not be at levels higher than those shown. Alarm setpoints are set near the local overflow point and may not be modified without written permission from the Engineer.

² TDH given is for the pressurized portion of the SPU system downstream of the Contractor’s connection, taken at the design flow rate shown. The design TDH of the temporary system must include this head in addition to all static and dynamic losses within the system furnished by the Contractor.

- C. The bypass must divert all flow around the work area and must maintain safe and dry conditions for all construction. Alternate diversion and discharge points may be proposed to the Engineer for review.
- D. Discharge of sewage to the downstream location must be executed in a manner that prevents back up of flows to the work area as well as in the downstream system.
- E. Contractor must brace/chain temporary pipe plugs in place. Plugs must be inspected and inflation pressure verified at the beginning and end of each shift, at a minimum.
- F. Monitoring equipment must be provided that is capable of measuring water level at the pumping location continuously during construction. Monitoring equipment must include alarms which automatically inform the Contractor if operational conditions specified herein are exceeded. See Part 3 of this section for response requirements.
 - 1. If operational conditions are exceeded, the Contractor must notify the Engineer and follow requirements of **Section 01 57 50 – Temporary Environmental Pollution Control** and **Section 00 72 00 – General Conditions, subparagraph 1.04.BB.3i**.
- G. Contractor is responsible for repairing any damage to the existing sewer caused during bypass operation at their own expense.
- H. Contractor is responsible for ensuring that hydraulic conditions inside the sewer after the bypass is removed are equal to existing conditions. No permanent structural modifications to the existing sewer may be made to accommodate bypassing. All temporary modifications must be removed and restored.
- I. Bypass operations must be fully compliant with the most recent revisions of the City of Seattle Standard Specifications.
 - 1. Refer to City of Seattle Standard Specifications **Section 7-17.3(2)K** for Temporary Sewer Bypass, except as modified by this Section.
- J. Any temporary bypass equipment that is above ground must be located in a manner fully compliant with provisions in **Section 01 55 80 – Public Convenience and Safety/Temporary Traffic Control** and **Section 00 73 00 – Supplementary Conditions**, and that causes the least possible obstruction, impact and inconvenience to the public.
- M. Bypass Pumping Noise Limits
 - 1. The Contractor is required to provide sound dampening enclosures or any other necessary measures around portable generators or pumping equipment, as necessary, to comply with the noise limits defined in **Article 3.01** of this Section from all bypass pumping equipment.
 - 2. If the specified noise limits cannot be met, the Contractor must obtain a noise variance from the Seattle Department of Construction and Inspections (SDCI) and comply with all requirements of the noise variance.
- N. Engine driven pumps and generators must be adequately fueled for at least 24 hours of continuous operation at all times. The Contractor must monitor fuel levels in accordance with **Article 3.02** of this Section.

3.02 FIELD QUALITY CONTROL, TESTING, AND INSPECTION

- A. Prior to beginning bypass operation, pumped portions of bypassing system must be installed and successfully pressure tested at 1.5 times the maximum operating pressure

of the system before bypassing any sewage. The test will be deemed successful if there are no visible leaks and the test pressure is maintained without pumping for 15 minutes with a pressure drop of less than 15 percent of the maximum operating pressure. The Contractor's system may be tested prior to connection to the SPU-owned force main.

- B. Prior to beginning bypass operation all temporary wiring must be inspected by the Engineer. **A minimum of 48 hours' notice is required prior to inspection by the Engineer.** Unsatisfactory wiring must be re-inspected prior to operation of the bypass. As part of the inspection, the Contractor must operate the primary and backup pumps on each power source and demonstrate that the ATS can properly switch power between sources in the event of failure of the primary power source.
- C. At least once per day the Contractor must visually inspect the entire length of the bypass system for leaks, verify the operation of all pumps, valves, floats, sensors, generators, and other equipment, and verify that pumps and generators are adequately fueled. Monitoring and inspection must also take place on holidays, weekends, or other non-working days while the system is in operation. The inspection results must be recorded in a daily inspection log. The Engineer may request the daily inspection log at any time during construction.
- D. Compliance with the provisions herein is subject to inspection by the Engineer at any time during construction.

3.03 BYPASS MONITORING AND RESPONSE

- A. At a minimum, the Contractor must execute the following protocol at all times while the bypass system is active:
 - 1. Set up temporary monitoring and alarm equipment prior to installing bypass equipment. Alarm setpoints must be as specified in Article 3.01 of this Section.
 - 2. Notify the Engineer at least 48 hours prior to disconnection of the onsite SCADA system. The Engineer will notify the SPU Operations Control Center of the disconnection.
 - 3. Install and implement the approved bypass plan.
 - 4. If an alarm is triggered, the Contractor must respond immediately, resolve the issue, and notify the Engineer. The Contractor must respond as soon as practically possible, but in no case longer than [X] hours from the time of alarm.
 - 5. If storage levels continue to rise more than 1 foot above the alarm level, the Contractor must notify the SPU Operations Response Center (206-386-1800) of the situation and request SPU support response, if appropriate. The Response Center will dispatch a response team if needed.
 - 6. In the event of an overflow or imminent overflow, the Contractor must immediately implement the approved Spill Prevention Plan to avoid or contain sewer overflows. The Contractor must immediately notify the SPU Operations Response Center and the Engineer of any overflows. Both the Contractor and Engineer must fulfill all regulatory reporting requirements, including notification to the Washington State Department of Ecology.

3.04 BYPASS REMOVAL AND DECOMMISSIONING

- A. Once the bypassing operation has begun, the bypass system must remain in continuous operation and must not be shut down between shifts or on non-working days without the approval of the Engineer.

- B. The full bypass system including any redundant pumps, power supplies, and other equipment, must remain in place until Operational Acceptance Testing and Control Center Acceptance testing have been completed and the Project Site has been accepted by the owner as defined in **Section 01 75 00 – Commissioning and Site Acceptance**.
- C. Within 24 hours prior to conclusion of bypassing, completely clean and pressure wash the diversion structure or wet well used for bypass pumping. Remove all grease, solids, and debris. This cleaning must be completed prior to facility startup.
- D. Within 24 hours prior to conclusion of bypassing, all surcharged inflow sewer branches listed below must be jet-cleaned. Any solids cleaned must be extracted. Flushing solids downstream is not permitted.

Pipe	Size/Type	Length	Location

- E.
- F. Following shutdown of the bypass system, all temporary plugs and bracing must be fully removed from the sewer system.
- G. Following shutdown of the bypass system, the Contractor must restore all temporary wiring interfacing with the Owner’s equipment to the design condition shown in the Drawings.
- H. All bypass piping and equipment must be decontaminated and flushed with water discharged to the public sewer system prior to removal from the Project Site to prevent discharge of wastewater into the environment.
- I. Restore temporary openings in structures and pavement.

END OF SECTION 01 35 05

SPECIFICATION SECTION 05 50 05

METAL GRATINGS

PART 1 - GENERAL

1.01 SECTION INCLUDES

- A. Prefabricated carbon steel bar gratings.
- B. Miscellaneous installation hardware and accessories.

1.02 REFERENCES

- A. ASTM A-36 Carbon Steel.
- B. ASTM A-510 Carbon Steel Wire Rods.
- C. ANSI/NAAMM- MBG-531-09 Metal Bar Grating Manual.

1.03 SCOPE OF WORK

- A. The Contractor must furnish, fabricate (where necessary) and install steel grating with all appurtenances, accessories and incidentals necessary to produce a complete installation as shown on the Drawings and as specified herein, and in accordance with the requirement of the Contract documents.
- B. Contractor is responsible for the coordination and construction of steel support framing and concrete embedment requirements for the installation of the grating.

1.04 SUBMITTALS

- A. Product Data: Submit the manufacturer's catalog pages including load tables, anchor details and standard installation details.
- B. Shop Drawings: Submit for approval Shop Drawings for the fabrication and erection of all gratings, based on construction Drawings. Include plans, elevations, and details of sections and connections as required. Show type and location of all fasteners. Show all penetrations shown on the Drawings, and any necessary supplemental framing, hinges, and accessories.

1.05 QUALITY ASSURANCE

- A. Manufacturer Qualification: A company specializing in the manufacture of metal bar gratings with not less than 10 years of documented experience.
- B. Fabrication tolerances are accordance with applicable provisions and recommendations of ANSI/NAAMM 531-09 Metal Bar Grating Manual.

1.06 FIELD VERIFICATION

- A. Contractor must provide field measurements prior to preparation of final Shop Drawings and fabrication where required to ensure proper fitting of the work.

PART 2 - PRODUCTS

2.01 GENERAL

- A. Description: Grating: Type 19-W-4 Carbon Steel Grating with hot dipped galvanized coating. Fabricated by welding cross bars perpendicular to main bearing bars.
 - 1. Main bearing bar spacing: 1-3/16" on center.
 - 2. Minimum bearing bar thickness and depth: As indicated on the Drawings.
 - 3. Maximum cross bar spacing: 4" on center.
 - 4. Top of main bearing bars are to be smooth.
- B. Fabrication: Band ends of grating with bars of same thickness as the main bearing bars. Weld banding flush with the top surface of the grating. Depth of banding to be 1/2" less than the depth of the main bearing bars.
- C. Penetrations: Where pipe and conduit penetrations are shown on the drawings, the Contractor must design, furnish, and install grating panels with banded cut-outs.
- D. Materials: Main Bearing bars and rectangular cross bars are to be Carbon Steel type ASTM A-36 Carbon Steel. Round Cross bars are to be per ASTM A-510. Banding and rod for hinges is to be Carbon Steel type ASTM A-36.
- E. Fabrication Tolerances are in accordance with ANSI/NAAMM MBG 531-09 Metal Bar Grating Manual. Prevent warping during galvanizing or straighten grating pieces following galvanizing.
- F. Finish: Gratings, frames, and accessories must be Hot-Dip Galvanized per ASTM A123.

2.02 ACCESSORIES

- A. Grating hold down fasteners must be manufacturer's recommended hardware for the support system provided. Hardware must be hot dip galvanized or stainless steel. Screws for hold down clips must be self-drilling and self-tapping. Screws requiring nuts to fasten hold down clips are not acceptable.
- B. Hinges must be fabricated and installed as shown on the Drawings.

PART 3 - EXECUTION

3.01 INSPECTION

- A. Upon receipt of material at the Project Site, the Contractor must inspect all materials for shipping damage. Any damage is to be noted on the shipping receipt/packing list and reported promptly to the shipper.

3.02 HANDLING AND STORAGE

- A. Delivery of Materials: Manufactured materials must be delivered in original, unbroken pallets, packages, containers, or bundles bearing the label of the manufacturer.
- B. Storage of Products: All materials must be carefully handled to protect them from abrasion, twisting, other deformations, and other types of damage.

3.03 INSTALLATION

- A. Prior to grating installation, the Contractor must inspect supports for correct alignment and conditions for proper attachment and support of the gratings. Any inconsistencies between contract drawings and supporting structure deemed detrimental to grating placement must be reported in writing to the Engineer prior to placement.
- B. Install grating in accordance with shop drawings and standard installation clearances as recommended by ANSI/NAAMM MBG-531-09 Metal Bar Grating Manual.
- C. Any field cuts for openings or panel trimming must be banded.
- D. Repair any damage to galvanizing with field-applied cold galvanizing compound (minimum three coats).

3.04 GRATING ATTACHMENT

- A. Use approved attachment system and fasteners to secure grating to supporting members as shown on the Drawings. Minimum 4 fasteners per panel. Where grating panels are designated on the Drawings as removable, omit hold-down clips and fasteners.

End of Section 05 50 05

SPECIFICATION SECTION 05 50 10

ANCHOR BOLTS AND ANCHORS

PART 1 – GENERAL

3.05 1.01 SUMMARY

- A. Section includes:
1. Anchor bolts cast-in concrete.
 2. Post installed expansion and adhesive anchor bolts.
 3. Drilled in concrete reinforcement dowels.

3.06 1.02 SUBMITTALS

- A. Manufacturer's product data on anchor bolts and adhesive for anchor bolts.
- B. Include design information, including material strength and bond strength of adhesive.
- C. Product ICC-ES reports (International Code Council).
- D. Manufacturer's installation procedures.
- E. Adhesive anchor installer certifications.

PART 2 – PRODUCTS

4.01 2.01 ANCHOR BOLTS AND DOWELS

- A. Comply with ASTM F1554 grade 36 hot-dip galvanized for carbon steel, and ASTM A193 Grade B8, stainless steel anchor bolts and rods, unless noted otherwise on the Drawings.
- B. Concrete reinforcement must meet the requirements of ASTM A615, Grade 60, deformed.
- C. Nuts: ASTM A194, Grade 8 or Grade 8M.
- D. Mechanical expansion anchors. Hilti KWIK Bolt 3 or approved equal. ICC-ES tested and approved.
- E. Eye Bolts: Details and dimensions per Drawings. Stainless steel Type 304; Fastenal or approved equal.
- F. Threaded Rods: Details and dimensions per Drawings. Stainless steel Type 304; Fastenal or approved equal.

2.02 ADHESIVE

- A. Adhesive for anchors must be Simpson Strong Tie SET-XP, Hilti HIT-RE-500 or approved equal. Adhesive must be ICC-ES tested and approved for cracked concrete and seismic loading.

PART 3 – EXECUTION

4.02 3.01 INSTALLATION

- A. Contractor must verify proper anchor bolt length to achieve embedment depth shown on the Drawings and have adequate extension for bolting structure or equipment.
- B. Comply with manufacturer's instructions including but not limited to:
 - 1. Proper drill hole size for anchor or dowel diameter.
 - 2. Type of drill, typically rotary percussion.
 - 3. Roughen hole if recommended by manufacturer, especially for oversized holes, using recommended equipment/methods.
 - 4. Drill hole cleaning, typically oil-less compressed air and rotary brushing.
 - 5. Proper mixing and placing of adhesive. Typically placed to bottom of hole with hose extension.
 - 6. Proper setting and tightening of expansion anchors.
 - 7. Do not bend anchor bolts for fit-up problems.
 - 8. Do not drill through reinforcement. If reinforcement is hit, consult with Engineer.

4.03 3.02 ANCHOR BOLTS CAST IN CONCRETE

- A. Use templates to assure proper anchor bolt location. Tie or otherwise restrain anchor bolts from moving during concrete placement.
- B. Verify and assure proper extension of anchor bolt for structure or equipment to be installed.

4.04 3.03 QUALITY ASSURANCE DURING CONSTRUCTION

- A. Quality assurance inspection of hole drilling, preparation, and strength testing of anchors will be performed by the SPU Materials Lab. Coordinate with the Engineer a minimum of 48 hours in advance of anchor installation to schedule required inspections.

4.05
4.06

End of Section 05 50 10

SPECIFICATION SECTION 08 31 00

ACCESS HATCHES

PART 1 - GENERAL

4.07 SUMMARY

- A. Section Includes:
1. Access hatches.
 2. Access hatch secondary fall through prevention systems.
- B. Related Sections include but are not necessarily limited to:
1. Division 00 - Procurement and Contracting Requirements
 2. Division 01 - General Requirements

4.08 QUALITY ASSURANCE

- A. Referenced Standards:
1. American Association of State Highway and Transportation Officials (AASHTO).
 2. ASTM International (ASTM):
 - a. A554, Standard Specification for Welded Stainless Steel Mechanical Tubing.
 - b. A653, Standard Specification for Steel Sheet, Zinc-Coated (Galvanized) or Zinc-Iron Alloy-Coated (Galvannealed) by the Hot-Dip Process.
 - c. A666, Standard Specification for Annealed or Cold-Worked Austenitic Stainless Steel Sheet, Strip, Plate, and Flat Bar.
 - d. B209, Standard Specification for Aluminum and Aluminum-Alloy Sheet and Plate.
 - e. B308/B308M, Standard Specification for Aluminum-Alloy 6061-T6 Standard Structural Profiles.
 - f. B429/B429M, Standard Specification for Aluminum-Alloy Extruded Structural Pipe and Tube.
 - g. F593, Standard Specification for Stainless Steel Bolts, Hex Caps Screws and Studs.

4.09 SUBMITTALS

- A. Shop Drawings:
1. See **Section 01 33 10 - Submittals** for requirements for the mechanics and administration of the submittal process.
 2. Product technical data including:
 - a. Shop Drawings including installation details.

- b. Acknowledgement that products submitted meet requirements of standards referenced.
 - c. Manufacturer's installation instructions.
 - d. 5-year warranty information on secondary fall through prevention system.
 - e. Manufacturer's extended guarantee or warranty for access hatches.
 - f. Structural calculations for design of access hatches for the loading specified in **Article 3.02** of this Section.
- B. Operation and Maintenance Manuals:
- 1. See **Section 01 33 10 - Submittals** for requirements for the mechanics and administration of the submittal process.
 - 2. See **subparagraph 1.03.K.3 of Section 00 73 00 – Supplementary Conditions** for requirements for the content of Operation and Maintenance Manuals.
- C. Warranty:
- 1. Manufacturer's extended guarantee or warranty, with Owner named as beneficiary, in writing, as special guarantee. The special guarantee must provide for correction, or at option of Owner, removal and replacement of access hatches found defective during a period of 5 years after date of Substantial Completion. Duties and obligations for correction or removal and replacement of defective Work as specified in **Section 00 72 00 – General Conditions**.

PART 2 - PRODUCTS

5.01 ACCEPTABLE MANUFACTURERS

- A. Subject to compliance with the Contract documents, the following manufacturers are acceptable:
- 1. Bilco Company.
 - 2. LW Products.
 - 3. USF Fabrication.
 - 4. Or approved equal.
- B. Submit request for substitution in accordance with **Section 01 33 10 - Submittals**.

5.02 MANUFACTURED UNITS

- A. All access hatches must be provided by the same manufacturer.
- B. Design Loading:
- 1. As specified in the Access Hatch Schedule in **Article 3.02** of this Section.
- C. Access Hatch:
- 1. Fabricate doors to open minimum 90 degrees but not more than 120 degrees, with assistance of coil or air spring operators and automatically lock into open position.

2. Frame: 1/4-IN minimum thickness mill finish aluminum channel with continuous anchor flange.
 3. Areas of the frame to be located in contact with concrete must be bituminous coated.
 4. Cover: 1/4-IN minimum thickness mill finish diamond plate aluminum.
 5. All hardware: ASTM F593 Type 316 stainless steel.
 6. Grip handle: Vinyl.
 7. Load Rating: Must be as specified in the Access Hatch Schedule shown in **Article 3.02** of this Section.
 8. Perimeter EPDM gasketed seal designed for weathertightness and odor resistance.
 9. Furnish with slam lock and removable key handle.
 10. Furnish with recessed padlock hasp minimum 3" wide x 7" long. Padlocks will be furnished by the Owner.
 11. Captive hold down bolts are required for any hatches to be installed in surfaces traveled by vehicles.
 12. Furnish with secondary fall through prevention system where noted on the hatch schedule in this Section.
 13. Size(s): Refer to the schedule in this Section. Specified sizes refer to actual clear opening unless otherwise noted.
 14. Furnish with a perimeter frame drain at the location shown in the Drawings.
 15. Clear hatch opening and door configuration must be as shown on the Drawings and in **Article 3.02** of this Section.
- D. Non-Slip Finishes:
1. Where specified, furnish hatches with a non-slip metallic finish. This finish must comply with all requirements for non-slip finishes shown in Seattle City Light Material Standard 7203.10.
 2. Diamond-plate finishes are not an acceptable finish where non-slip finish is specified.
- E. Access hatch secondary fall through prevention system:
1. Platform:
 - a. 1-IN minimum thickness FRP or aluminum bar grating for 300 psf load rating.
 - b. Panel must be designed to meet the requirements of OSHA standard 29 CFR 1910.23 and be equipped with a hold-open device to lock the grating panel(s) in the open position.
 - c. Panel must be hinged on the same side as the cover unless otherwise noted on the Drawings.

- d. Finish:
 - 1) Powder coated if aluminum.
 - 2) Color: Safety orange or safety yellow.
- 2. Hardware:
 - a. ASTM F593 Stainless steel Type 316.
 - b. Tamper proof ASTM F593 Type 316 stainless steel bolts.
- 3. Provide positive latch to hold grating in upright position. Latches must be located such that they are easily accessible without leaning over the hatch opening.
- 4. Size: Size grating platform to allow 6-IN clear space on each unhinged side for visual observation.
- 5. Grating bars must be arranged such that they do not interfere with ladders, ladder rungs, or telescoping ladder safety posts. Gratings that require installation of ladders with top rung more than 12 inches below finished grade will not be accepted.
- 6. Secondary fall through prevention system must be installed at the factory per the manufacturer.

F. Guardrail Sockets, Posts, and Chains

- 1. Where specified in **Article 3.02**, the hatch must include guardrail post sockets. The manufacturer must provide aluminum posts and stainless steel chains that span between the chains and the hatch leaf when hatch is in the open position. Posts must extend to 48" above finished grade and must include both a top chain and intermediate chain.

a. Typical Arrangement for Single Leaf Hatches:

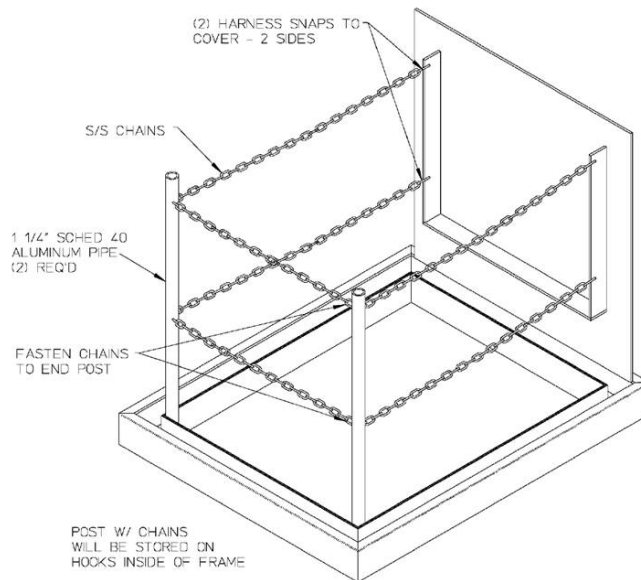

- b. Where double door hatches are specified, hatches must be furnished with removable chains that span between the hatches in the open position (both sides).

5.03 ACCESSORIES

A. Load Rating Plates:

1. Attach plates to each hatch with engraved text stating the maximum design live load allowed.
2. Plates must be of the same material as the hatch or stainless steel grade 316.
3. Text:
 - a. Size: minimum 1/4-IN height.
 - b. Depth of engraving: 3 mils.
 - c. If load rating plate metal is different than the access hatch, provide a neoprene gasket under the plate to separate the stainless steel from the aluminum cover or frame.

5.04 ACCESS HATCH SCHEDULE

STRUCTURE NAME	ACCESS HATCH PURPOSE	HATCH CLEAR OPENING AND CONFIGURATION	FALL PROTECTION GRATING	POSTS AND CHAINS	LOAD RATING	FINISH
PS 62	Dry Well Access Hatch	36"x30", Single Door, Hinge Short Side	No	No	300 psf	Non-slip
PS 62	Wet Well Access Hatch	36"x30", Single Door, Hinge Short Side	No	No	300 psf	Non-slip
PS 62	Bypass Vault Hatch	36"x36", Single Door	No	Yes	H-20	Non-slip
PS 63	Dry Well Access Hatch	30"x30", Single Door	No	No	300 psf	Non-slip
PS 63	Wet Well Access Hatch	30x30", Single Door	No	No	300 psf	Non-slip
PS 71	Wet Well Access Hatch	36"x36", Single Door	No	No	H-20	Non-slip

NOTE: Access hatch sizes shown are nominal clear opening dimensions. Contractor must coordinate actual hatch dimensions with the existing and proposed vaults/structures and verify with the Engineer through the submittal process.

PART 3 – EXECUTION

6.01 INSTALLATION

- A. Orient door opening direction and other features as shown on the Drawings. Mock up installation and confirm final orientation with the Engineer in the field prior to bolting or casting in place.
- B. Install products in accordance with manufacturer's instructions. Locate latches, locking mechanisms, and lockboxes such that they are easily accessible and do not interfere with access to or operation of other components.
- C. Where hatches are cast into concrete structures, whether precast or cast-in-place, pathways for frame drains must be maintained clear with blockouts or similar methods.

- D. Unless otherwise noted on the Drawings, drains from dry well hatches must be hard piped to the dry well sump. Unless otherwise noted on the Drawings, drains from wet well hatches must be piped to 1 foot below the grating level. Schedule 80 PVC pipe may be used for drains. Drain brackets must be hot dip galvanized.
- E. Protect installed hatches throughout construction. Repair damaged coatings in accordance with Manufacturer's recommendations.

End of Section 08 31 00

--	--	--	--	--	--	--	--	--

Scope Key:

- A** Remove existing coatings and install new coatings per **Article 3.07**
- B** Prep and top-coat existing coatings to remain (including salvaged and reinstalled equipment) per **Article 3.09**
- C** Coat newly installed materials per **Article 3.07**

- B. Furnish spare touch-up paint.
- C. Do Not Paint or Finish the Following Items/Areas:
 - 1. Items fully factory-finished unless specifically so indicated; materials and products having factory-applied primers are not considered factory-finished.
 - 2. Items indicated to receive other finishes.
 - 3. Items indicated to remain unfinished.
 - 4. Fire rating labels, equipment serial number and capacity labels, and operating parts of equipment.
 - 5. Glass.
 - 6. Concealed pipes, ducts, and conduits.
 - 7. Electrical panels and cabinets.
 - 8. Electrical conduits.
 - 9. Sheet metal or plastic ventilation ducts.
 - 10. Mechanical equipment (e.g. fans, pumps, valves) unless otherwise noted.
 - 11. Stainless steel or galvanized metals, supports, beams, bracing, etc., and conduits, unless otherwise noted.
 - 12. Hatches.
 - 13. Exterior surface of pump station structures.
 - 14. Pipe flange bolts, nuts, washers, and hardware that are galvanized, zinc plated, or stainless steel.
- D. Repair of existing water leakage in structures that is required prior to paint application that is not otherwise addressed in the Drawings and Specifications will be addressed as a Changed Condition to the Contract. Any directed repairs will be made using the materials and methods described in this Section.
- E. Coatings for new pumps are not addressed in this Section. See **Section 43 21 13 – Vertical Centrifugal Non-Clog Sewage Pumps** for pump coating requirements.
- F. Restore any disturbed roadway markings and install roadway markings as shown in the Drawings.

1.03 LEAD PAINT

- A. Existing coatings to be removed may contain lead. See **Section 02 83 00 – Lead Handling Procedures** for lead paint testing and Contract requirements relating to the removal, handling, and disposal of lead containing coatings.
- B. If any other suspected regulated materials are discovered, the Contractor must follow **Section 01 35 30 – Discoveries of Contaminated Material(s), Dangerous Waste(s), and TSCA Waste(s)**.
- C. Any regulated materials, other than lead paint as identified in the lead paint testing document, will be addressed as a changed condition to the Contract.

1.04 SUBMITTALS

- A. See **Section 01 33 10 - Submittals** for requirements for the submittal process.
- B. Product Data: Provide data on all finishing products, including VOC content, manufacturer's recommended preparation and curing procedures, coating thicknesses, and test data.
- C. Equipment Protection Plan: Written plan detailing the Contractor's proposed methods for protecting existing equipment to remain, in accordance with **Article 3.01** of this Section.
- D. All submittals required by **Section 02 83 00 - Lead Handling Procedures** must be approved by the Engineer prior to beginning any removal, painting or coating activities.

1.05 DELIVERY, STORAGE, AND HANDLING

- A. Deliver products to Project Site in sealed and labeled containers; inspect to verify acceptability.
- B. Container Label: Include manufacturer's name, type of paint, brand name, lot number, brand code, coverage, surface preparation, drying time, cleanup requirements, color designation, and instructions for mixing and reducing.
- C. Paint Materials: Store at minimum ambient temperature of 45 degrees F and a maximum of 90 degrees F, in ventilated area, and as required by manufacturer's instructions. Materials must be stored in a covered area with secondary containment (e.g. tub) to prevent discharge to surface water.

1.06 FIELD CONDITIONS

- A. Do not apply materials when surface and ambient temperatures or moisture levels are outside the ranges required by the paint product manufacturer.
- B. Follow manufacturer's recommended procedures for producing best results, including testing of substrates, moisture in substrates, and humidity and temperature limitations.
- C. Provide lighting level of 80-foot candles measured mid-height at substrate surface and at third points in the dry wells.

PART 2 - PRODUCTS

2.01 MANUFACTURERS

- A. Approved Manufacturers:

1. Carboline Company.
2. ICI Paints (Devoe Coatings).
3. The Sherwin-Williams Company.
4. Tnemec Company, Inc.
5. PPG Paints.
6. Wasser Coatings.
7. Or approved equal.

2.02 MATERIALS

- A. Accessory Materials: Linseed oil, shellac, turpentine, paint thinners, and other materials not specifically indicated but required to achieve the finishes specified of commercial quality. Use products compatible with painting materials and approved by paint manufacturer.
- B. Degreasers: Heavy duty commercial cleaner/degreaser suitable for removing contamination from painted surfaces. Trisodium phosphate or similar.
- C. Paint materials and equipment must be compatible in use.
- D. Primer, Intermediate, and Finish coats must all be from the same coatings manufacturer. Prime coats must be compatible with and appropriate for use on surface to be coated.
- E. Provide all paint and coating products used in any individual system from the same manufacturer; no exceptions.
- F. Sealing and crack repair materials: Furnish materials for repair and sealing of existing concrete surfaces against water intrusion in accordance with **Paragraph 3.02.D** of this Section.
 1. Products for surface patching must be quick-setting hydraulic cement such as SpeedPlug by Euclid Chemical or approved equal suitable for patching active leaks.
 2. Products for crack injection must be epoxy resin or polyurethane chemical grout suitable for sealing active leaks.
 3. For structural repair of concrete, see **Section 03 30 00 – Cast-in-Place Concrete**.
- G. Substitutions: See **Section 01 33 10 - Submittals**.

2.03 PAINTS AND COATINGS - GENERAL

- A. Paints and Coatings: Ready mixed, unless intended to be a field-catalyzed coating.
 1. Provide paints and coatings of a soft paste consistency, capable of being readily and uniformly dispersed to a homogeneous coating, with good flow and brushing properties, and capable of drying or curing free of streaks or sags.
 2. Supply each coating material in quantity required to complete entire project's work from a single production run.
 3. Do not reduce, thin, or dilute coatings or add materials to coatings unless such procedure is specifically described in manufacturer's product instructions.

- B. Primers: Where the manufacturer offers options on primers for a substrate, use primer categorized as "best" by the manufacturer.
- C. Volatile Organic Compound (VOC) Content:
 - 1. Provide coatings that comply with the most stringent requirements specified in 40 CFR 59, Subpart D--National Volatile Organic Compound Emission Standards for Architectural Coatings.
 - 2. Determination of VOC Content: Testing and calculation in accordance with 40 CFR 59, Subpart D (EPA Method 24), exclusive of colorants added to a tint base and water added at Project Site; or other method acceptable to authorities having jurisdiction.
- D. Colors: As specified in **Article 3.07** of this Section.
- E. Non-Slip Additives: Must be durable, wear-resisting, and use non-reactive natural or artificial aggregates that are compatible with polyurethane, acrylic or epoxy coatings and can be applied with the coating material. SharkGrip by H&C or approved equal.
- F. Paint for touch up and repair of existing coatings shall be suitable for application to marginally prepared surfaces.
- G. For each finish coat paint product and color used, furnish an unopened 1 gallon can to the Owner for future touch-up purposes.

2.04 PAINT FOR RESTORATION OF PAVEMENT MARKINGS

- A. Paint for restoration of roadway striping will be per City of Seattle Standard Specifications **Section 9-29**.

PART 3 - EXECUTION

3.01 PROTECTION OF EXISTING AND NEW EQUIPMENT

- A. Where existing mechanical or electrical equipment is designated to remain or new equipment is installed prior to painting, the Contractor must protect it in place throughout the preparation and finishing operation. Equipment must be protected from dust, debris, solvents, blasting media, paint, vapors, and other harmful substances. Equipment protection must be fully in place prior to beginning any preparation or finishing work. Work must not begin prior to review and approval of the Equipment Protection Plan by the Engineer.

3.02 PREPARATION

- A. Remove existing coatings, clean surfaces thoroughly, and correct defects prior to coating application. Coating removal must be to the bare substrate unless otherwise noted. Any disturbance of existing lead-containing coatings must be in accordance with **Section 02 83 00 - Lead Handling Procedures**.
- B. For concrete surfaces, cut off existing unused anchor bolts flush with the surface and grind smooth any sharp edges as specified in **Section 02 41 19 – Selective Structure Demolition**. Patch over with repair mortar as specified in **Paragraph 2.03.D of Section 03 30 00 – Cast-in-Place Concrete**.
- C. Prepare surfaces using the methods recommended by the coating manufacturer for achieving the best result for the substrate under the project conditions.

- D. Where necessary, stop leaks caused by cracks, construction joints, or other defects in existing concrete surfaces using products listed in **Paragraph 2.02.F** of this Section. Clean and prepare surface and apply and cure product in accordance with manufacturer's recommendations. Any leaks beyond those identified in the Drawings and Specifications will be considered a Changed Condition.
- E. Remove or mask surface appurtenances, including nameplates, hardware, light fixture trim, escutcheons, and fittings, prior to preparing surfaces or finishing.
- F. Seal surfaces that might cause bleed through or staining of topcoat.
- G. Remove mildew from impervious surfaces by scrubbing with solution of tri-sodium phosphate and bleach. Rinse with clean water and allow surface to dry.
- H. Concrete and Unit Masonry Surfaces to be Painted: Remove existing paint, dirt, loose mortar, scale, salt or alkali powder, and other foreign matter. Remove oil and grease with a solution of tri-sodium phosphate; rinse well and allowed to dry. Remove stains caused by weathering of corroding metals with a solution of sodium metasilicate after thoroughly wetting with water. Allow to dry.
- I. Pump Station Dry Well Concrete Floors and Traffic Surfaces to be Painted: Remove existing paint, contamination, acid etch, and rinse floors with clear water. Verify required acid-alkali balance is achieved. Allow to dry.
- J. Galvanized Surfaces to be Painted: Remove surface contamination and oils and wash with solvent. Apply coat of etching primer.
- K. Corroded Steel and Iron Surfaces to be Painted: Prepare using at least SSPC-PC 2 (hand tool cleaning) or SSPC-SP 3 (power tool cleaning) followed by SSPC-SP 1 (solvent cleaning).
- L. Uncorroded Uncoated Steel and Iron Surfaces to be Painted: Remove grease, mill scale, weld splatter, dirt, and rust. Where heavy coatings of scale are evident, remove by hand or power tool wire brushing or sandblasting; clean by washing with solvent. Apply a treatment of phosphoric acid solution, ensuring weld joints, bolts, and nuts are similarly cleaned. Prime paint entire surface; spot prime after repairs.
- M. Shop-Primed Steel Surfaces to be Finish Painted: Sand and scrape to remove loose primer and rust. Feather edges to make touch-up patches inconspicuous. Clean surfaces with solvent. Prime bare steel surfaces. Re-prime entire shop-primed item.
- N. Interior Wood Surfaces to Receive Opaque Finish: Wipe off dust and grit prior to priming. Seal knots, pitch streaks, and sappy sections with sealer. Fill nail holes and cracks after primer has dried; sand between coats. Back prime concealed surfaces before installation.

3.03 APPLICATION

- A. Apply products in accordance with manufacturer's instructions. Particular care must be given to maintaining recommended coating intervals, curing times, and curing temperatures. The Contractor is responsible for furnishing heaters, dehumidifiers, and other climate control equipment necessary to keep the painted environment within the manufacturer's specified curing conditions.
- B. Do not apply finishes to surfaces that are not dry. Allow applied coats to dry before next coat is applied. Do not re-coat surfaces within the manufacturer's specified drying time.
- C. Apply each coat to uniform appearance.

- D. Sand wood and metal surfaces lightly between coats to achieve required finish.
- E. Vacuum clean surfaces of loose particles. Use tack cloth to remove dust and particles just prior to applying next coat.
- F. Reinstall electrical cover plates, hardware, light fixture trim, escutcheons, and fittings removed prior to finishing.
- G. Apply non-slip additives to finish coats where specified. Apply per manufacturer's instructions.

3.04 FINISHING MECHANICAL AND ELECTRICAL EQUIPMENT

- A. Paint shop-primed equipment unless otherwise noted. Do not paint fully finished equipment (e.g. epoxy coated valves and fittings).
- B. Remove unfinished louvers, grilles, covers, and access panels on mechanical and electrical components and paint separately.
- C. Prime and paint insulated and exposed pipes, boxes, hangers, brackets, collars and supports, except where items are pre-finished.
- D. Paint both sides and edges of plywood backboards for electrical and telephone equipment before installing equipment.
- E. Color-code equipment, piping, conduit, and exposed ductwork in accordance with requirements indicated. Color band and identify with flow arrows names and numbering.
- F. Reinstall electrical cover plates, hardware, light fixture trim, escutcheons, and fittings removed prior to finishing.

3.05 FIELD QUALITY CONTROL

- A. Wet Film Thickness: Monitor during application of each successive coat.
- B. Dry Film Thickness: Measure the thickness of each coat applied using non-destructive dry film thickness gages. Calibrate gages and perform thickness measurements in accordance with SSPC-PA2. Disputes regarding coating thickness applied will be resolved by use of a Tooke Gage (destructive scratch gage) to the extent required. Repair damage created by destructive testing using the complete coating system specified.
- C. Inspection Devices: Contractor must possess, use, and make available for use by Owner, inspection devices in good working order for dry film thickness measurement. Furnish with the inspection device, U.S. Department of Commerce, National Bureau of Standards certified thickness calibration plates to verify accuracy of the dry film thickness gages.

3.06 CLEANING

- A. Collect all waste material; place in closed metal containers and remove daily from the Project Site.
- B. Remove masking, over-spray, or drips on adjacent surfaces.

3.07 PAINT SYSTEM SCHEDULE

- A. Unless otherwise specified, paint systems of The Sherwin-Williams Company and Tnemec are listed as the Basis-of-Design products. Equivalent systems of other

manufacturers specified in **Article 2.01** of this Section are acceptable.

SUBSTRATE		DESCRIPTION	DRY MILS
A. DRY WELL INTERIOR – CONCRETE WALLS AND CEILING Finish color: Federal Standard Color 24583 (Light Green)	Prime Coat	Pro-Industrial Heavy Duty Block Filler, B42W00150	10 – 18
	First Coat	Tile-Clad HS Catalyzed Epoxy, B62-100 Series	2.5 – 4
	Second Coat	Tile-Clad HS Catalyzed Epoxy, B62-100 Series	2.5 – 4
	Final DFT		15 – 26
B. DRY WELL CONCRETE FLOORS AND BOTTOM 2 FEET OF WALLS Finish color: Federal Standard Color 30152 (Burgundy)	Prime Coat	Armorseal 1000 HS Clear, B67-2000 Series	3 - 5
	First Coat	Armorseal HS Polyurethane B65-220 series	2 – 3
	Second Coat	Armorseal HS Polyurethane B65-220 series	2 – 3
	Anti-Slip Aggregate	H&C SharkGrip (floors only)	
	Final DFT		6 – 9
C. METAL – EXTERIOR NON-SUBMERGED Finish color: Federal Standard Color 26270 (Medium Gray) Note: Fixed bollards must be painted City of Seattle Safety Yellow	Prime Coat	Recoatable Epoxy Primer, B67 Series, B67V5 Hardener	3 – 6
	First Coat	Hi-Solids Polyurethane, B65-300 Series	3 – 5
	Second Coat	Hi-Solids Polyurethane B65-300 Series	3 – 5
	Final DFT		9 – 14
	NOTE: PRIMER ONLY AVAILABLE IN GRAY, TAN, AND RED OXIDE		
D. METAL – DRY WELL VAULT AND WET WELL INTERIOR NON-SUBMERGED Finish color: Federal Standard Color 26270 (Medium Gray)	Prime Coat	Recoatable Epoxy Primer, B67 Series, B67V5 Hardener	3 – 6
	First Coat	Tile-Clad HS Catalyzed Epoxy, B62-100 Series	2.5 – 4
	Second Coat	Tile-Clad HS Catalyzed Epoxy, B62-100 Series	2.5 – 4
	Final DFT		8 – 14

SUBSTRATE	DESCRIPTION		DRY MILS
NOTE: PRIMER ONLY AVAILABLE IN GRAY, TAN, AND RED OXIDE			
E. METAL – SUBMERGED, SPLASH OR VAPOR ZONE (WASTEWATER)	Prime Coat	Macropoxy 646, B58 Series	5 – 10
	First Coat	Macropoxy 646, B58 Series	5 – 10
	Second Coat	N/A	
	Final DFT		10 – 20
F. TOP COAT OF EXISTING DRY WELL COATINGS Finish Color: Federal Standard Color 24583 (Light Green)	First Coat	Pro-Industrial Multi-Surface Acrylic, Semi-gloss	1.5-2
	Second Coat	Pro-Industrial Multi-Surface Acrylic, Semi-gloss	1.5-2
	Final DFT		3-4
G. TOP COAT OF EXISTING OR SALVAGED AND REINSTALLED METALS AND EQUIPMENT Finish Color: Federal Standard Color 26270 (Medium Gray)	First Coat	Macropoxy 646, B58 Series	3-6
	Second Coat	Macropoxy 646, B58 Series	3-6
	Final DFT		6-12
H. EXTERNAL PLASTIC AND PVC MATERIALS Finish Color: Federal Standard Color 26270 (Medium Gray)	First Coat	Pro-Industrial Multi-Surface Acrylic, Semi-gloss	1.5-2
	Second Coat	Pro-Industrial Multi-Surface Acrylic, Semi-gloss	1.5-2
	Final DFT		3-4

3.08 PAVEMENT MARKINGS

A. Install pavement markings per City of Seattle Standard Specifications **Section 8-22**.

3.09 TOP COAT OF EXISTING COATINGS

A. Painting activities may not occur until after all paint-disturbing work is complete.

B. The Contractor must:

1. Remove all loose or flaking paint. Removal down to bare substrate is not required.
2. Clean and degrease surfaces to remove all oil, grease, dust, dirt, and oxide. Fully remove any cleaning product residue.
3. Contain and dispose all cleaning fluids and loose paint flakes per **Section 02 83 00 – Lead Handling Procedures**.

4. Apply first and second coats of paint per the Paint System Schedule (**Article 3.07** of this Section). Allow adequate time between coats per the manufacturer's recommendations.
- C. Thickness testing will not be required for touch-up painting.

3.10 TOUCH UP AND SPARE PAINT

- A. For each type and tint of top-coat paint, furnish 1 gallon of touch-up paint to the Owner. Touch-up paint must be furnished in full, unopened cans labeled with the location and substrate to which it is applied and delivered to the Project Site.

End of Section 09 90 00

SPECIFICATION SECTION 10 00 00

BUILDING SPECIALTIES

PART 1 - GENERAL

- C. 1.01 SUMMARY
 - A. Section Includes:
 - 1. Fire extinguishers.
 - 2. Identifying labels.
- D. 1.02 SUBMITTALS
 - A. Submit in accordance with **Section 01 33 10 - Submittals**.
 - B. Product Data: Fully describe all products proposed for use.

PART 2 - PRODUCTS

- E. 2.01 FIRE EXTINGUISHERS
 - A. Provide one 10-lb fire extinguisher for each pump station. Fire extinguisher must be appropriate for use on live electrical equipment; however, CO2 extinguishers are not acceptable. Shell of extinguisher must be painted OSHA Red. Extinguisher must have a State and/or local Fire Marshal's inspection and fill tag dated within 90 days of the Site Acceptance Date and issued by the State and/or local Fire Marshal of the State in which the extinguisher is installed. Provide wall mounting bracket for fire extinguisher. Extinguishers must be of heavy duty construction with brass valving and must be rechargeable.
 - B. Acceptable Manufacturers:
 - 1. Amerex.
 - 2. Or approved equal.
- F. 2.02 IDENTIFYING DEVICES
 - A. Comply with all applicable Federal, OSHA, State and Local requirements.
 - B. Identifying Decal: "Fire Extinguisher": 4" x 18" long; pressure sensitive vinyl adhesive-back; manufactured by Seton, Brady, or approved equal.

PART 3 - EXECUTION

- G. 3.01 INSTALLATION
 - A. Fire Extinguishers: Comply with NFPA Standard No. 10. Mount wall brackets and install extinguishers where shown on the Drawings.
 - B. Identifying Label: Mount prominently on wall above each extinguisher.

End of Section 10 00 00

SPECIFICATION SECTION 23 00 00

VENTILATION

PART 1 - GENERAL

- H. 1.01 Summary
- A. Section Includes:
 - 1. Furnish all labor, materials, equipment, services, and incidentals required to provide complete, integrated, and operating ventilating systems for the buildings and structures in this project. Materials and equipment to be supplied must be new, of the best quality as specified, and as shown on the Drawings.
 - 2. Work included in this Section:
 - a. Ductwork internal to pump stations
 - b. Dampers
 - c. Registers and diffusers
 - d. Fans
 - e. Enclosures for external fans and associated equipment
 - f. Caps for external ducts
 - 3. For work related to installation of external buried ductwork see **Section 40 23 00 – Process Pipe, Fittings, and Accessories.**
- I. 1.02 RELATED SECTIONS
- A. Related Sections include the following:
 - 1. Section 01 33 10 – Submittals
 - 2. Section 05 50 10 – Anchor Bolts and Anchors
 - 3. Section 23 80 00 – Odor Control Equipment
 - 4. Section 40 05 01 – General Requirements for Equipment
 - 5. Section 40 07 00 – Mechanical Identification
 - 6. Section 40 23 00 – Process Pipe, Fittings, and Accessories
 - 7. Section 40 91 10 – Primary Elements and Transducers
- J. 1.03 REFERENCES
- A. This Section incorporates by reference the latest revisions of the following documents. They are part of this Section as specified and modified herein. In the event of conflict between the requirements of this Section and those of the listed documents, the requirements of this Section prevail. Unless otherwise specified, references to documents mean the documents in effect on the Bid Opening Date. If referenced documents have been discontinued by the issuing organization, references to those documents mean the replacement documents issued or otherwise identified by that

organization or, if there are no replacement documents, the last version of the document before it was discontinued.

Reference	Title
AMCA 511	Certified Ratings Program for Air Control Devices
ASHRAE CH 1	Handbook - Equipment Volume, Duct Construction
ASHRAE CH 33	Handbook - Fundamentals Volume, Duct Design
NFPA 90A	Standard for the Installation of Air Conditioning and Ventilating Systems
SMACNA	HVAC Duct Construction Standards Metal and Flexible
UL 181	Factory-made Air Ducts and Connectors

K. 1.04 SUBMITTALS

- A. Procedures: **Section 01 33 10 – Submittals.**
- B. Provide Shop Drawings and technical literature covering all equipment and accessories being furnished under this Section and in accordance with **Section 01 33 10 - Submittals**. The data must include information to demonstrate compliance with all the requirements of these Specifications. Submit detailed drawings for fan enclosures showing layout of all equipment and accessories located in the enclosure.
- C. Provide Shop Drawings showing proposed ductwork supports, mounting brackets, and any proposed changes to ductwork layout and routing. A separate submittal is required for each site.
- D. Manuals: Furnish manufacturer's installation, lubrication and maintenance manuals, bulletins, and parts lists. Furnish separate list of recommended spare parts.
- E. Certificate of Unit Responsibility attesting that the Contractor has assigned, and that the manufacturer accepts, unit responsibility for fans, enclosures, and accessories (where applicable) in accordance with the requirements of this section and **Paragraph 1.04.B of Section 40 05 01 - General Requirements for Equipment**. No other submittal material will be reviewed until the certificate has been received and found to be in conformance with these requirements.
- F. Submit factory test results of sample configurations as described in **Paragraph 1.05.E of this Section**.
- G. Qualifications and certifications for the licensed firm providing testing and balancing services for the Project.
- L. 1.05 QUALITY ASSURANCE
- A. Codes: Comply with all rules and regulations of authorities having jurisdiction over the work specified herein.
- B. All equipment furnished under this Section must 1) be of a design and manufacturer who has been regularly engaged in the design and manufacture of the equipment and 2) be demonstrated to the satisfaction of the Engineer that the quality is equal to equipment made by those manufacturers specifically named herein.

- C. The Drawings must be taken in a sense as diagrammatic. Size of ducts and pipes, including general method of running them, are shown, but it is not intended to show every offset and fitting nor every mounting bracket or structural difficulty that may be encountered.
- D. Factory Testing: Perform factory testing of the fan and fan enclosure assembly. Perform one test of each fan/enclosure configuration. Verify the output of fan meets required performance. Measure noise levels on all sides of the enclosure. Measure ambient temperature levels and temperatures inside the enclosure.

PART 2 - PRODUCTS

M. 2.01 DUCTWORK

- A. Provide fabricated and/or manufactured duct systems as required to accommodate the installation. Manufactured systems must be single-wall spiral pipe and fittings with standard spiral pipe connector, Sheet Metal Connectors, Inc. or approved equal.
- B. Stainless steel ductwork must be Type 316 and must be constructed in accordance with SMACNA "HVAC Duct Construction Standards".
- C. Aluminum ductwork must be alloy 3003-H14 conforming to ASTM B209 and ASTM B211 and must be constructed in accordance with SMACNA "HVAC Duct Construction Standards."
- D. Flexible connections in dry well ducts must be made of neoprene fiberglass cloth, installed in folds, and of sufficient length to accommodate the maximum deflection resulting from vibration and contraction without causing strain. Minimum length in folded position must be 4 inches. Provide end connections as required to accommodate duct, fan, etc. Flexible duct connections must be Ventfabrics Inc. "Ventglas"; Duro-Dyne Corp. "Neoprene"; or approved equal.
- E. Flexible connections in wet well ducts must be made of a single continuous piece of neoprene sized to fit snugly to duct or fan nozzles on each end and secured with stainless steel clamp bands. Flexible connections must be Flexible Couplings by Fernco, or approved equal.
- F. Duct support details and spacing must conform to SMACNA "HVAC Duct Construction Standards". The specific support detail utilized must be as appropriate for each particular duct and location, except as otherwise shown. Duct supports must be stainless steel. Anchor bolts must be stainless steel, sized for the mounting bracket and associated load, complying with **Section 05 50 10 – Anchor Bolts and Anchors**.
- G. Duct to pipe transition coupling must consist of a PVC body and stainless steel compression clamps. Coupling must be rated up to 140 F and have a 5 percent expansion/contraction factor. Plastec Ventilation, Fernco, or approved equal.
- H. Contractor must provide any additional ductwork, fittings, etc., as required to accommodate the configuration of the fans, registers, and accessories as submitted and approved.
- I. Ductwork in unclassified spaces (dry well) must be of aluminum or stainless steel construction. Ductwork in classified spaces (wet well) must be constructed of FRP or Schedule 80 PVC. All ductwork and fittings (e.g. dampers, housings) within a given run must be of the same material.

- J. Buried external ductwork must comply with **Section 40 23 00 – Process Pipe, Fittings, and Accessories.**
- N. 2.02 DAMPERs
- A. Volume Dampers: All volume dampers must be made of material (similar to the ductwork) two gauges thicker than the duct in which the damper is located. Each damper must have an operator with indicator handle and a locking mechanism. Damper operator must be Young Regulator Company "Valcalox" No. 403B; Ventfabrics Inc. "Ventloc" No. 637; or approved equal.
- B. Pressure Relief Dampers: All pressure relief dampers must be substantially constructed of the same material as the duct in which the damper is located, or of stainless steel. Damper must have an adjustable setpoint by weight or spring. Stainless steel balanced backdraft damper by Ruskin or approved equal.
- O. 2.03 fans
- A. Wet Well Fans: Corrosion resistant fans must be factory fabricated assemblies having fan, fan motor, and fan housing. Fan capacities, electrical characteristics, special features, and accessories must be as indicated in the fan schedules on the Drawings. The fans must include polypropylene housing and impellers, stainless steel assembly hardware, and be spark resistant. Motors must be constant speed, explosion proof, Class 1 Div. 1 rated, and be UL listed. Provide fans with automatic (gravity) backdraft dampers where indicated on the Drawings. Fans installed outdoors must include a weatherproof, noise attenuating enclosure configured as shown on the Drawings. Fans by Plastec Ventilation or approved equal.
- P. **B. FAN SIZING MUST BE PER THE FAN SCHEDULES SHOWN ON THE DRAWINGS.**
- C. Fans located in outdoor enclosures must be furnished with a lockable local disconnect switch mounted adjacent to the fan as shown on the Drawings.
- Q. 2.04 registers and diffuser
- A. Supply Registers must be of sizes indicated on the Drawings. Diffuser must be aluminum construction, double deflection with $\frac{3}{4}$ -inch blade spacing. Diffusers must be suitable for duct mounting as shown on the Drawings. Diffusers must be Titus Model 300, Price, or approved equal. Provide fabricated duct transition pieces as needed to allow register to be installed as shown.
- R. 2.05 FAN ENCLOSURES
- A. Where shown on the Drawings, Fans installed outdoors must include a weatherproof enclosure of the general configuration shown on the Drawings.
 - 1. Enclosures must be of 304 stainless steel construction with continuous seam welding. Enclosures must anchor to a concrete slab with stainless steel bolts. The size, number, and type of anchors will be determined by the enclosure manufacturer. Steel thickness must be 12 gauge minimum. Utilize bending to minimize the number of welds to the extent feasible. Stainless steel surfaces must have a polished finish.
 - 2. Enclosure tops must incorporate sufficient slope to prevent water ponding. In no case may the slope be less than 1:50.

3. Enclosures must use a 304 stainless steel heavy-duty padlock hasp suitable to accommodate a BEST Series 11B padlock with 5/16" shank (locks are Owner-furnished). Hinges must be 304 stainless steel with non-removable hinge pins. All hardware (hinges, hasp, etc) must be continuously welded to the enclosure.
4. Provide 1-inch minimum vinyl foam acoustic lining with vinyl facing. Acoustic lining must be capable of being steam cleaned and be chemically resistant.
5. Provide minimum 6" clearance between fan and inside of enclosure on all sides.
6. Enclosure must provide a maximum sound level of 55 dBA @ 5 feet when fans are operating at the air flows listed on the Drawings. Performance of each configuration must be validated by factory acoustic testing prior to shipment.
7. Provide enclosures of the general configuration(s) as shown on the Drawings. Sound enclosure manufacturer must coordinate with the equipment manufacturer listed on schedule requirements and special provisions for inlet ducting, discharge ducting, appurtenances such as dampers, flexible duct connections, inlet or discharge silencers, intake filters, vibration isolators, seismic restraints, motors, drives and guards, fan supports, electrical connections, and electrical safety disconnect switches. The sound enclosure manufacturer must also make special provisions to allow access to serviceable items such as bearings, lubrication, seals, dampers, belts, motors and access doors.
8. Sound enclosure manufacturer must coordinate with fan manufacturer on requirements for fan motor cooling and temperature rise and ensure adequate ventilation louvers are provided for the enclosure to meet those requirements assuming full direct sunlight exposure and ambient temperatures of up to 110 degrees F. A minimum of 2 louvers for fan cooling must be provided per enclosure.
9. All louvers or openings (other than doors) must be screened for insect exclusion with 10x10x20 gauge stainless steel mesh.
10. Enclosure manufacturer must have unit responsibility for the fan, enclosure, and accessories.
11. As manufactured by FanAir or approved equal.

2.06 CAPS FOR EXTERNAL VENT STACKS

- A. Where shown on the Drawings, furnish caps for external vent stacks.
 1. Caps for external ductile iron vent stacks 6" and smaller must be heavy duty cast-iron, vandal proof vent caps. Caps must be specifically manufactured to fit securely on the type of duct material specified, including ductile iron where indicated. Josam Model 26700 or approved equal.
 2. Caps for PVC vent stacks must be Weather Caps by Plastec Ventilation, Inc. or approved equal.
 3. Caps for external ducts larger than 6" must be specially fabricated of stainless steel by the Contractor as shown on the Drawings.
 4. All vent caps, regardless of size or material, must have inlets screened for bird and insect exclusion with heavy duty stainless steel mesh with openings not larger than 1/16 inch.

2.07 FILTERS AND FILTER HOUSINGS

- A. Filters for mist and grease removal
1. Filters must consist of a layered system with layers of stainless steel mesh sandwiching co-knit stainless steel mesh and fiberglass yarn, designed for elimination of mist and grease in wastewater systems.
 2. Filters must be capable of elimination of mists of 10 microns and larger with 99% effectiveness.
 3. Filters must be sized to meet the manufacturer's recommended velocity for optimum mist removal (maximum 400 fpm). Filter size must not exceed 12"x12" unless otherwise noted on the Drawings.
 4. Pressure drop through filters must not exceed 1.0 inches water column at the design flowrate noted in the Drawings.
- C. Filter Housings
1. Must be of stainless steel construction, with a 3/4" standard threaded drain nipple at the lowest point. Size to fit associated filter snugly without air bypass.
 2. Furnish with latching door for filter removal.
 3. Furnish with adapters suitable to connect to adjacent ductwork.

2.08 LABELING AND IDENTIFICATION

- A. Provide labels for all equipment and ductwork as required in **Section 40 07 00 – Mechanical Identification.**

2.09 FLOAT VALVES FOR BELOW-GRADE STRUCTURES

- A. Where shown on the Drawings, furnish float valves for duct ends in below grade structures subject to occasional flooding.
1. Float valves must be of cast 316 stainless steel construction with an ANSI B16.5 125lb compliant flange matching the nominal size of the associate duct. Valves must be powder coated.
 2. Valves must include a float mechanism that seals the valve when submerged and prevents water ingress to the attached duct. The float must be of stainless steel construction with a matching nitrile sealing gasket.
 3. Open area of the valve in the open position must be equal to or greater than the cross-sectional area of the associated nominal duct size.
 4. Valves must be equipped with removable 316 stainless steel screens with openings no larger than 3/16".
 5. 1700 Series by Wager Co, Inc, or approved equal.

PART 3 - EXECUTION

S. 3.01 GENERAL

- A. Protection: Fully protect all unfinished parts of the materials and equipment against damage, dust, and debris from whatever cause during the progress of the work and until Site Acceptance. All materials and equipment must be covered while in storage and

- during construction in such manner that no finished surfaces are damaged or marred and all moving parts are kept perfectly clean and dry.
- B. Installation must be in strict accordance with the best practice of the several trades and with the respective manufacturer's instructions and recommendations. Installation must include furnishing the required oil and grease for initial operation in accordance with the manufacturer's instructions.
- C. All sheet metal ductwork must be erected in a first class and workmanlike manner and must be in accordance with the SMACNA "HVAC Duct Construction Standards" and as specified above. No ductwork may be fabricated or installed until it has been carefully coordinated with other trades. All transverse duct joints must be taped airtight. Duct dimensions shown are "net" inside clear. Each air supply outlet and each air return or outside air intake must have either an integral volume control device or be furnished with a volume damper.
- D. Dry well fans must be installed with flexible fabric isolation (complying with **Paragraph 2.01.D**) on both the supply and discharge side, located within 1 foot of the fan.
- E. Where external duct piping enters buried structures, cut piping flush with interior face of the wall unless otherwise shown in the Drawings. Interior ductwork must connect to the wall using a wall flange or plenum unless otherwise shown in the Drawings. Seal interior ductwork to wall with silicone sealant.
- F. Locate access panels for fans and filter housings such that they are easily accessible and not blocked by walls, adjacent equipment, or other features.
- G. Testing and Adjusting Equipment and Controls:
1. The equipment and controls of this Section must be completely tested, adjusted, and placed in operating condition.
 2. Retest equipment and controls, as necessary, during the progress of the work. No work may be covered until it is properly tested and made tight.
 3. Supply the testing apparatus and make all necessary connections for applying the tests.
 4. When about to turn the apparatus over to the Owner, put all parts of the apparatus in perfect working order and thoroughly clean out all parts of the equipment.
- H. Testing and Balancing:
1. Testing and balancing is required to verify the systems and equipment are performing as intended. A testing and balancing firm licensed by the National Environmental Balancing Bureau is required.
 2. Testing and balancing must include items listed below. Testing and balancing must be documented and performed in the presence of the Owner.
 - a) Adjust supply and exhaust fans to achieve the required flow setpoints for the fans while maintaining the required pressurization in the ventilated space. Balance by adjusting fan speed, if possible, prior to adjusting dampers. Direct measurement of airflow is required. Testing and

- balancing must occur with the pump station in normal operating condition (hatches and doors closed, etc.).
- b) Final airflow must not exceed the specified 'Design Flow' CFM values shown in the Drawings by more than 10 percent.
 - c) Balance all unclassified spaces (dry wells) to have a pressure of 0.1" w.g. relative to ambient. Balance all classified spaces (wet wells) to have a pressure of -0.1" w.g. relative to ambient. In no case may the flow rate between supply and exhaust fans differ by less than 5 percent.
 - d) Measurement of voltage and current from each fan to determine operating power.
 - e) Submit documentation of balancing results at each facility. Include a copy of the fan curves with operating points indicated. Balancing results must be submitted to the Engineer within 2 Business Days of balancing.
 - f) Mark the position of each damper and fan potentiometer with a permanent marker and indicate date after balancing is complete.
3. Testing and balancing is considered part of the Equipment Acceptance Test and must be completed before Systems Acceptance Testing can begin as specified in **Section 01 75 00 – Commissioning and Site Acceptance**.

T. 3.02 PROJECT COORDINATION

- A. The Contractor's Superintendent must coordinate the exact location, space priorities and sequence of installation of all HVAC-related work including mechanical and electrical/controls with each other and with all other trades.
- B. The location of mechanical and electrical/controls work may be indicated diagrammatically on the Drawings. Actual locations must follow locations shown on the Drawings as closely as practicable, but must be altered or adjusted in the field as required by the following:
 - 1. Organize mechanical and electrical/controls work to make efficient use of space. Combine similar items into groups; make all runs parallel to or at right angles with building lines.
 - 2. Layout and install work to provide adequate space and access for adjustment, servicing, and maintenance and maximize space available for future installation of additional services or replacement of existing services.
 - 3. Coordinate location of fixtures, registers, grills, outlets, switches, panelboards, pullboxes, access doors, and other exposed mechanical and electrical items with functional and visual elements. Verify conflicting locations with the Engineer before proceeding.
- C. Review Shop Drawings and Product Data prior to submission to assure that physical characteristics and service requirements are compatible with Contract requirements, field conditions, and other items submitted.
- D. Verify that required services such as electrical power characteristics, control wiring, and utility requirements of items and equipment submitted and furnished are compatible with services provided. Notify the Engineer of potential problems prior to ordering items or equipment and prior to installing services or completing construction in areas where services would have to be installed.

- E. Modify ductwork and provide fittings and accessories as required to install flow switches per **Section 40 91 10 – Primary Elements and Transmitters**.
- F. Ventilation systems must remain in operation throughout construction. The Contractor must provide temporary ventilation systems as needed for worker safety. Provide temporary fans, ductwork, electrical connections, and other items necessary.
- U. 3.03 HVAC CONTROL DESCRIPTIONS
 - A. Dry Well: Ventilation of the Dry Well is required to keep the space electrically unclassified. The supply and exhaust fans serving the Dry Well must run continuously. Flow switches on the supply and exhaust ducting will verify operation of the fans. Failure of either fan must create an alarm signal in SCADA and change the status of the entry indicator light outside the Dry Well from green to red.
 - B. Wet Well: Ventilation of the Wet Well is not required for electrical classification purposes – the space is classified as Class 1 Division 1. Where Wet Well supply and exhaust fans are provided, they must operate continuously.
 - C. See **Section 40 90 05 – Control Loop Descriptions** for additional HVAC Control information.

End of Section 23 00 00

SPECIFICATION SECTION 23 80 00

ODOR CONTROL EQUIPMENT

PART 1 - GENERAL

1.1 WORK INCLUDED

- A. Odor Control Systems at Pump Stations **62 and 63.** [INSERT LOCATIONS HERE]
1. This Section includes the work necessary to furnish and install 2 complete up-flow activated carbon/media odor control systems.
 2. The systems must include the following components:
 - a. FRP Media Adsorber Vessel
 - b. Odor Absorbing Media
 - c. Fan and Motor Assembly
 - d. Control Panel
 - e. Integral Prefilter
 - f. Sound / Weather enclosure
 - g. Outlet silencer
 3. Provide 2 spare pre-filter pads for each site.
 4. Provide one (1) spare blower motor for each site.

1.2 SUBMITTALS

- A. Copies of all materials required to establish compliance with the Specifications must be submitted as specified in **Section 00 72 00 - General Conditions** and **Section 01 33 10 - Submittals**. Submittals must include at least the following:
1. Odor Control
 - a. Vessel fabrication details and materials of the components must be included in Shop Drawings and submitted for approval before fabrication.
 - b. Catalog information, descriptions, specifications layouts, sketches and other information sufficient to clearly and readily demonstrate compliance with all parts of the Specifications and Drawings.
 - c. Dimensional and weight information. Include empty weight and operating weight with media.
 - d. A list of 10 recent installations where similar equipment by the manufacturer is currently in service; include contact name, telephone number, mailing address, and the names of the engineer, owner, and installation contractor. One reference must have been in operation for over 5 years. References must include single deep bed carbon media units that utilize a top-mount fan with integral prefilter.
 - e. Resin manufacturer's certificate listing the nomenclature, composition, and characteristics of the resin must be furnished with the vessel.
 - f. Letter from the resin manufacturer stating recommended corrosion liner for sewer gas service.
 - g. Activated carbon and engineered media data sheets and certificate of origin.

- h. Structural calculations for vessel anchors and anchor bolts, prepared and sealed by a Professional Engineer registered in the State of Washington.
- i. Vessel fabricator's certificate of compliance with fabrication requirements.
- j. Suggested spare parts list to maintain the equipment in service for a period of 1 year.
- k. Certified sound test results from an acoustical test laboratory accredited by NVLAP or A2LA with minimum 10 years experience analyzing noise produced by mechanical equipment.
- l. Certificate of Unit Responsibility attesting that the Contractor has assigned, and that the manufacturer accepts, unit responsibility as specified in this Section and **Paragraph 1.04.B of Section 40 05 01 - General Requirements for Equipment**. No other submittal material will be reviewed until the certificate has been received and found to be in conformance with these requirements. For the purposes of this Section, Unit Responsibility applies to odor control media vessel, prefilter, fan, fan housing, and system enclosure.

1.3 CODES AND STANDARDS

A. Odor Control

1. ASTM International

- a. D2563, Standard Practice for Classifying Visual Defects in Glass Reinforced Plastic Laminate Parts.
- b. D2854, Standard Test Method for Apparent Density of Activated Carbon.
- c. D3299, Standard Specifications for Filament-Wound Glass-Fiber-Reinforced Thermoset Resin Corrosion-Resistant Tanks.
- d. D3467, Standard Test Method for Carbon Tetrachloride Activity of Activated Carbon.
- e. D3982, flanges.

1.4 QUALITY ASSURANCE

A. Odor Control

- 1. The system supplier must have process design experience in carbon adsorption systems for wastewater, demonstrating at least 10 years' experience. At least 5 systems must have been in operation for over 5 years. Experience should be specific to process design and not component (FRP Vessel) fabrication. Companies whose primary business is the manufacture of fiberglass products are not acceptable.
- 2. Designer: Professional Engineer registered in the State of Washington.
- 3. Vendor must have a local service center with 200 miles of the system location.

1.5 NFPA 820

- A. The Odor Control Systems must be designed and fabricated in compliance with the National Fire and Protection Agency Code 820. The vessel and ductwork must be manufactured using materials that achieves a Class I flame spread rating.

1.6 RELATED WORK

- A. Division 1 Sections.
- B. Other Division 23 Sections.

C. Divison 26 – Electrical.

1.7 WARRANTY

A. Manufacturer's Warranty: Submit, for Owner's acceptance, manufacturer's standard warranty document executed by authorized company official. Manufacturer's warranty is in addition to, and not a limitation of, other rights Owner may have under the Contract.

1. The warranty of the motor and equipment is to be free from defects in material and workmanship for a period of 1 year (Standard) from date of Substantial Completion. Any units or parts which prove defective during the warranty period will be replaced at the Manufacturer's option when returned to Manufacturer, transportation prepaid.

PART 2 - PRODUCT

2.1 ODOR CONTROL EXHAUST FAN

A. Furnish odor control fan complying with requirements for wet well fans specified in **Section 23 00 00 – Ventilation**. Motors for fans must be certified for operation in Class 1 Division 1 hazard classification environments unless otherwise noted.

B. System Requirements and Components

1. Fan provided with corrosion resistant damper to modulate flow rate. Acceptable materials are stainless steel, FRP, and PVC.
2. Exhaust Fan must be integral to and supplied as part of the Odor Control System, mounted with rubber isolators.
3. Type 316 stainless steel hardware and fasteners.
4. 3/8" minimum 316 Stainless Steel anchor bolts.
5. Provide flexible rubber couplings between fan and ducting and odor control unit and ducting, Fernco or approved equal with 316 SST hose clamps.

2.2 odor control system

A. General

1. The system supplier must furnish all of the items required to provide a complete, tested and operating packaged odor control system including, media drum, prefilter to remove mist and grease and a fan mounted directly on top of the media drum covered with an acoustical sound enclosure.
2. Basis of design is the ECS 60-Series V1-100-TM-CST.

B. SYSTEM SUPPLIERS

1. ECS.
2. Pure Air Filtration.
3. Or approved equal.

2.3 SERVICE CONDITIONS

A. The odor control system must be designed to remove the odorous constituents from the process air stream under the following operating conditions:

B. Process Parameter Value

C.	Duty	Continuous
D.	Elevation Above Sea Level	20 feet
E.	Location	Outdoors
F.	Inlet Air Temp	40 to 120 degrees F
G.	Inlet Relative Humidity	30% to 99%
H.	Volumetric Flow Rate	100 cfm
I.	H ₂ S Loading	Avg 5 ppm / Peak 50 ppm
J.	Removal Required	H ₂ S: 99% removal / max 0.05ppm whichever is less stringent
K.	The media vessel must conform to the following parameters:	
L.	Process Parameter	Value
M.	Vessel Type	Single Bed / Top Mounted Fan
N.	Vessel Material of Construction	FRP or approved equal
O.	Pressure Drop (Max)	Vessel (Inlet to Outlet): 5" w.c.
P.	Media Volume	2-foot bed depth; 3.5 cubic feet
Q.	Vessel Dimensions	Inside diameter (min): 30"
R.	Height	Not to exceed 72" at the highest point including housing, not including exhaust pipe
S.	Maximum Sound at 5 feet	50 dBA

2.4 ADSORBER VESSEL

- A. Vessel must be dimensionally stable with internal pressure in direct sunlight and not become brittle in extreme cold conditions. Construction method must provide a naturally insulated internal surface. The FRP adsorber vessel must be filament-wound, manufactured in accordance with ASTM D3299. The visual defects, per ASTM D2563, must not exceed Level II on the vessel interior and Level III on the vessel exterior. The resin must be suitable for continuous exposure to saturated water vapor, hydrogen sulfide gas, and their associated acidic products. The system must provide a class 1 flame spread rating. Contact molded accessories must be manufactured in accordance with NBS PS15. The final color must be selected by the Owner or Engineer. A certificate from the resin manufacturer listing the nomenclature, composition, and characteristics of the resin must be furnished with the vessel.
1. Tie down lugs and lifting lugs must be 316 stainless steel. Quantity and design must be determined in the PE stamped vessel calculations.

2. The adsorber vessel must be complete with integral media screen support structure, access ports, air inlet connection, air outlet with discharge silencer oriented as shown on the Drawings, pressure differential assembly, a drain connection, sample port nozzles, 316 stainless steel grounding rod and attachment and all necessary accessories as shown on the Drawings and/or specified within. All exhaust air must leave the vessel at the top. Provide sufficient access ports so that all internal parts can be easily removed from the vessel. All metal parts must be Type 316 stainless steel with no metallic parts contacting the media except for grounding purposes.
3. Access covers must be airtight at the pressure equal to or higher than the corresponding fan static pressure. The fabrication details and materials of the components must be included in shop drawings, and submitted for approval before fabrication.
4. Vessel design and airflow configuration must be furnished to accommodate a single bed media or activated media layer.
 - a. Single Bed Requirements:
 - 1) The bed and vessel configuration must permit easy media replacement.
 - 2) The bed must be supported on a polypropylene screen and fiberglass grating.
 - 3) Screen and grating must be removable through access port.
 - 4) The grating and its support ledge must be capable of supporting the load imposed by the depth of media specified.
 - 5) Media support beams, structure or otherwise must all be manufactured using the same resin as specified in the vessel construction. All components must have a 100-mil minimum corrosion barrier applied to any surfaces exposed to the corrosive airstream or the body must be constructed of corrosion resistant material.
5. Each activated media bed must be grounded with a 316 stainless steel rod to prevent static electricity from accumulating and a ground connection must be located on the outside of the vessel as shown in the Drawings.
6. All cut-walls from tank wall nozzle cutouts must be reinforced as required by service conditions. Press molded or compression molded flanged nozzles are not acceptable.
7. Add ultraviolet absorbers to surfacing to improve weather resistance.
8. No dyes, pigments or colorants except in exterior gel coating.

B. Media

1. General: Both the H₂S and polishing media shall be spherical or cylindrical porous pellets capable of absorbing and removing contaminants throughout the entire pellet. The media must have a UL Class 1 fire rating.
2. H₂S Media Characteristics: Porous pellets of high grade bituminous activated carbon.
 - a. Min. H₂S Removal Capacity (by volume): 0.30 g/cc
 - b. Min. H₂S Removal Capacity (by weight): 0.63 g/g
 - c. Apparent Density: 0.48 g/cc (30 lbs/ft³)
 - d. Max. Moisture Content: 15%
 - e. Hardness: 95 min
 - f. Ignition Temperature: 400 degrees C

- g. Min. Pellet Diameter: 1/8-inch
- 3. Polishing Media Characteristics: Spherical porous pellets formed from powdered activated alumina, binders and potassium permanganate to oxidize a wide variety of gaseous contaminants.
 - a. Min. H₂S Removal Capacity: 0.13 g/cc (by volume), 8% (by weight)
 - b. Min. SO₂ Removal Capacity: 0.06 g/cc (by volume), 3.5% (by weight)
 - c. Min. NO Removal Capacity: 0.06 g/cc (by volume), 2.5% (by weight)
 - d. Min. NO₂ Removal Capacity: 0.016 g/cc (by volume), 1.0% (by weight)
 - e. Min. Formaldehyde Removal: 0.04 g/cc (by volume), 1.4% (by weight)
 - f. Max. Moisture Content: 20%
 - g. Crush Strength: 40 to 60%
 - h. Max. Abrasion Loss: 3%
 - i. Min. Pellet Diameter: 1/8-inch
 - j. Permanganate content: 8% to 12%

2.5 Sound Attenuation, weather enclosure, stack and outlet silencer

- A. Unit must be supplied with an outlet silencer that will also convey the exhaust air downward to a duct connection as shown on the Drawings. Silencer must be a monolithic FRP structure and create the following insertion loss:
- B.
- C.

D.		Insertion Loss (dB)							
E.	Fre que ncy , Hz	F.	G.	H.	I.	J.	K.	L.	M.
N.	De cib el	P.	Q.	R.	S.	T.	U.	V.	W.
O.	Re duc tion								

- X.

Y.	Insertion Loss (dB)
----	---------------------

Z.	F r e q u e n c y, H z	AA.	BB.	CC.	DD.	EE.	FF.	GG.	HH.
II.	D e c i b e l R e d u c t i o n	JJ.	KK.	LL.	MM.	NN.	OO.	PP.	QQ.

RR.

- SS. B. A FRP fan enclosure must be provided by the system supplier. Construction and performance must be as follows:
1. Walls must be vacuum-formed construction with two layers of FRP over a honey-comb core.
 2. Resin, liner, color and exterior coating system must be the same as specified for the adsorber vessel.
 3. Enclosure must be manufactured so that it can be easily removed for maintenance.
 4. Enclosure must be single-piece construction. No seams or joints are allowed. Bolt-together kit enclosures are not acceptable.
 5. Enclosure must have sound-adsorb lining on all internal surfaces.
 6. Coordinate enclosure design and lining with fan/motor heat dissipation requirements and design to mitigate heat buildup as required.
 7. Enclosure must produce the following fan noise transmission loss:

Transmission Loss						
Frequency, hz	125	250	500	1,000	2,000	4,000
Decibel Reduction	10	17	23	24	25	26

2.6 INSTRUMENTATION

- A. Pressure differential instruments must be provided and include Magnehelic style pressure gauges allowing determination of the pressure loss in inches of water column across the media. The range must be 0-10 inches of water. Tubing must be bonded to a solid acrylic plastic block that contains safety condensate traps. Magnehelic must be Dwyer or equal.
- B. Sampling Ports: Each adsorption unit must have three 2-inch diameter sample ports which extend into the media bed 1 foot minimum, suitable for extracting media samples. Provide one grain thief that is capable of extracting a core sample of the in-place media through the sample ports. Ports must be adequate to provide suitable extraction of air samples from the media bed and be nonbinding. Each port nozzle must extend outside the vessel wall and be blocked off with a 2-inch ball valve. One additional air sampling port must be provided above the media bed.

2.7 PRE-FILTER

- A. Pre-filters are required for removal of mist and grease. Filters may be integral with the media vessel or housed in a separate adjacent enclosure.
- B. Housing: Housing must be manufactured using fiberglass reinforced plastic. Stainless or alternate plastic materials are not acceptable. Manufacturer must have a minimum of 10 years experience in the design and supply of similar equipment. Manufacturer must retain the services of an independent inspector who is responsible to confirm the prefilter has been manufactured in accordance with this specification and all FRP work meets or exceeds ASME RTP-1 level 2 visual inspection criteria.
 - 1. The fiberglass reinforced plastic resin and gel coat must meet the requirements of the media vessel.
 - 2. Housing must have machined UHMW guides to prevent stainless frame on filter pad from scratching or damaging the corrosion liner.
 - 3. Filter housing must be designed for 1.5 times the maximum operating pressure (positive and negative) with a maximum of 1/8" deflection.
 - 4. Housing must have an access door for pad removal complete with EPDM gasket and 316 Stainless hinges / quick latches. Access doors must have stainless toggle clamps for easy pad access. Bolt-on access doors are not acceptable.
 - 5. Housing must drain directly into the vessel and not require any additional piping. Housing must have a drain tap compatible with common dimension PVC pipe and fittings.
- C. Filter Pad
 - 1. Filter pad must be composed of layers of stainless steel and fiberglass mesh suitable for removing mist and grease particles as specified below. Filters must be washable and reusable.
- D. Dimensions / Design:
 - 1. End connections must be sized for a maximum air velocity of 2500 f/m. Flange dimensions must match the connecting ductwork. Flange thickness must not be less than that listed in ASTM 3982.
 - 2. Inlet cone must be designed so that the airstream can spread evenly over the pad surface. Cone angle must be less than 60 deg.
 - 3. Housing must be sized so that air velocity through the filter pad is 400 ft/min.
 - 4. Particle removal efficiency must be 99% of particles 10 microns or larger.

2.8 ADSORBER VESSEL ACCESSORIES

- A. 16 gauge SST name plate with ¼" die-stamped equipment tag number securely mounted in a readily visible location.
- B. 316 SST lifting lugs.
- C. 316 SST anchor bolts sized by the equipment manufacturer (1/2" minimum) and supplied by Contractor.

2.9 DISCONNECT SWITCHES AND MISCELLANEOUS ELECTRICAL COMPONENTS

- A. Disconnect switches and miscellaneous electrical components must comply with **Section 26 05 00 – Electrical Basic Requirements** as well as other requirements shown in the Drawings.
- B. Disconnect switches must be rated for the designated environment outdoor applications (such as hazardous classification and/or outdoor wet location) for the installation area noted on the space classification diagrams shown in the Drawings. If no classification is shown, a Class 1 Division 1 rating is required in accordance with installation per current NEC requirements.

2.10 Piping for Drains and miscellaneous connections

- A. Piping for vessel and filter drains and other miscellaneous connections must be Schedule 80 PVC complying with **Section 40 23 00 – Pipe, Fittings, and Accessories**.

PART 3 - EXECUTION

3.1 GENERAL

- A. Protection: Fully protect all unfinished parts of the materials and equipment against damage from whatever cause during the progress of the work and until final completion. All materials and equipment must be covered while in storage and during construction in such manner that no finished surfaces must be damaged or marred and all moving parts must be kept perfectly clean and dry.
- B. Installation must be in strict accordance with the best practice of the several trades and with the respective manufacturer's instructions and recommendations. Installation must include furnishing the required oil and grease for initial operation in accordance with the manufacturer's instructions.
- C. Coordinate with electrical drawings, specifications, and details for electrical installation requirements.
- D. Route drains from the media vessel, filter housing, and other drains to the adjacent service/yard drain shown on the Drawings.
- E. The Contractor must submit a certificate from the Manufacturer stating that the installation of the equipment is satisfactory, that the equipment is ready for operation, and that the operating personnel have been suitably instructed in the operation and care of each unit.
- F. Functional testing must be conducted after the installation of the fans and Odor Control System and all appurtenances and the equipment has been operated for a sufficient period to make any corrections or adjustments. Each media vessel must be subject to field functional tests under actual operating conditions to determine that operation is satisfactory and in compliance with the Specifications.
- G. The Contractor will provide, calibrate, and install all temporary gauges and meters, and install all temporary piping and wiring required for the functional tests.

- H. The functional tests must include the following:
 - 1. Alignment: Test complete assemblies for correct and proper alignment and connection, and quite operation
 - 2. Flow Throughput: Measured by system or temporary instrumentation.
 - 3. Balance pressurization of space served by odor control unit in coordination with **Section 23 00 00 – Ventilation.**
 - 4. Discharge and Inlet Static Pressure: Measured by system instrumentation or temporary measurement devices.
 - 5. Test all system components for proper adjustment and operation in both manual and automatic operating modes.
- I. System Start-up
 - 1. Must be performed by qualified representative of the manufacturer.

3.2 MANUFACTURER'S SERVICES

- A. The Contractor must provide training for the operation and maintenance of the Odor Control System for the Owner's forces. As part of the training session, equipment manufacturer representatives must be provided to assist in start-up and present training information. Training duration must be as follows:
 - 1. Wet Well Odor Control System – 4 hours.
- B. O&M manuals: Manufacturer to provide O&M manuals for odor control equipment.

END OF SECTION 23 80 00

SPECIFICATION SECTION 26 24 19

MOTOR CONTROL CENTERS

PART 1 – GENERAL

1.01 DESCRIPTION

- A. This Section specifies freestanding, factory assembled 600 volt motor control center (MCC). MCC and major components specified herein must be manufactured and furnished by a single manufacturer.
- B. Related Sections: The work of the following Sections is related to the work of this Section. Other Sections, not referenced below, may also be related to the proper performance of this work. It is the Contractor's responsibility to perform all the Work required by the Contract documents.
1. Section 01 33 10 - Submittals
 2. Section 26 05 00 – Electrical: Basic Requirements
 3. Section 26 05 73 - Overcurrent Protective Device Coordination Study
 4. Section 26 08 13 – Acceptance Testing
 5. Section 26 24 00 – Panelboards
 6. Section 26 27 15 - Miscellaneous Electrical Devices
 7. Section 26 29 23 - Variable Frequency Drive Motor Controllers
 8. Section 26 43 13 – Low voltage Surge Protection Devices (SPD)

1.02 REFERENCES

- A. This Section contains references to the following documents. They are a part of this section as specified and modified. Where a referenced document contains references to other standards, those documents are included as references under this Section as if referenced directly. In the event of conflict between the requirements of this Section and those of the listed documents, the requirements of this Section prevail.

Reference	Title
ANSI/NEMA ICS 1	Industrial Control Systems: General Requirements
ANSI/NEMA ICS 18	Motor Control Centers
NFPA 79	Electrical Standards for Industrial Machinery
UL 845	Motor Control Centers

- B. Codes and Standards: Motor Control Centers and all components must be Underwriters Laboratory listed to UL 845 and must conform to NEMA ICS-1 and ICS-18 standards.

1.03 SUBMITTALS

- A. Procedures: **Section 01 33 10 - Submittals.**
- B. A copy of this specification section, with addendum updates included, and all referenced and applicable sections, with addendum updates included, with each paragraph check-marked to indicate specification compliance or marked to indicate requested deviations from specification requirements.
 - 1. A check mark denotes full compliance with a paragraph as a whole. If deviations from the specifications are indicated, and therefore requested by the Contractor, underline each deviation and denote by a number in the margin to the right of the identified paragraph, referenced to a detailed written explanation of the reasons for requesting the deviation. The Engineer is the final authority for determining acceptability of requested deviations. The remaining portions of the paragraph not underlined will signify compliance on the part of the Contractor with the specifications.
 - 2. Failure to include a copy of the marked-up specification sections, along with justification(s) for any requested deviations to the specification requirements, with the submittal is sufficient cause for rejection of the entire submittal with no further consideration.
- C. Elementary and interconnection diagrams as required in **Article 2.07** of this Section, in accordance with NFPA 79 and/or NEMA ICS 18 Part 1 standards.
- D. Arrangement and layout drawings of the motor control center enclosures depicting equipment fit in the intended location including areas of permissible conduit and cable entries. A list of material and components must accompany the layout drawings to include:
 - 1. Starter, feeder tap, and component schedule indicating size and type of protection
 - 2. Identification of units and location in the MCC
 - 3. Time current curves for all protection devices
 - 4. Nameplate schedule
- E. Manufacturer's certification that the following items are capable of interrupting and/or withstanding the specified short circuit current condition and continuous current rating:
 - 1. Bus bar bracing
 - 2. Feeder tap units
 - 3. Starter units
 - 4. Main incoming units
- F. Front view elevation with starter, feeder tap, elementary wiring, and compartment schedule.

- G. Manufacturer's certification and calculations that the equipment complies with the seismic requirements and **Section 26 05 00 - Electrical: Basic Requirements**.
- H. Information needed for the electrical system analyses reports specified in **Section 26 05 73 - Overcurrent Protective Device Coordination Study**.
- I. Results of factory tests as specified within this Section.
- J. Results of field tests as specified within this Section.
- K. Operation and maintenance manuals:
 - 1. Installation instructions
 - 2. Manufacturer's product data
 - 3. Manufacturer's instructions for configuring, data registers and programming remote network data exchange using Modbus RS-485 interface connectivity

1.04 FACTORY TESTS

- A. All system components must be factory-wired and tested as a system prior to shipment. Testing must verify system operation.

1.05 SPATIAL LAYOUT

- A. The motor control center overall dimensions must be coordinated to fit in the available space as shown on the Drawings and must not exceed 5 sections.

PART 2 – PRODUCTS

2.01 ACCEPTABLE MANUFACTURERS

- A. Motor Control Centers must be **Square D Model 6, Allen Bradley Centerline 2100, or approved equal.**

2.02 SERVICE

- A. Motor control centers must be rated 600 volts, 60 Hertz, 3 phase, 4 *wire with neutral with neutral lug termination assembly* and must be suitable for operation at the specified voltages and short circuit capacities.

2.03 STRUCTURE AND CONSTRUCTION

A. STRUCTURE:

1. Motor control centers must be made of 14 gauge steel minimum and, unless otherwise shown, each section must be **20** inches deep. The individual unit compartments must be 6 inches minimum high. Typical height and width are shown on the design drawings and must not exceed 92 inches high and 5 sections. Compartments must have pan-type doors with a minimum of two quarter-turn hold-down latches; and neoprene gaskets.
2. A full height vertical wire way, 30 square inch minimum, must be provided for each vertical motor control center section. The wire way must contain full height removable doors. Horizontal wire ways must be provided top and bottom, extending the length of motor control centers.
3. Bottom channel sills must be mounted front and rear of the vertical sections extending the full length of the motor control center lineup. A removable lifting angle must be mounted on top and must extend the width of the motor control center lineup.

B. CONSTRUCTION:

1. Motor control centers located indoors must have NEMA 12, gasketed enclosures.
2. Starter units, size 4 and smaller, and feeder tap units less than 225 amperes must be drawout plug-in construction with hardened, tin-plated copper free-floating stabs, steel spring backups. The door must have interference tabs which prevent door closure if unit is improperly installed.
3. Units must be latched in the position to assure proper bus contact. The unit disconnect device must be interlocked to prevent removal or reinsertion of a unit when the disconnect is in the "ON" or "TRIPPED" positions.
4. Fusible switch or circuit breaker disconnect operators must be capable of accommodating three padlocks for locking in the "OPEN" position.
5. Hardware for mounting future starter and feeder tap units must be provided at compartments specified as "FUTURE."
6. The motor control center must have a minimum overall short circuit withstand rating of 42,000 amps RMS symmetrical unless specifically noted otherwise with a higher rating on the Drawings. The overall withstand must apply to the buses and down to the lowest rated component in the overall motor control center assembly.

- C. SEISMIC BRACING: Motor control centers and related equipment must conform to the seismic anchorage and bracing requirements and mounting detail as shown on the Drawings.

2.04 FINISH AND COLOR

- A. The finish and color must be in accordance with **Section 26 05 00 – Electrical: Basic Requirements**.

2.05 BUS

- A. GENERAL: Bus must be tin-plated copper with bolted connections between vertical and horizontal bus bars. Access for tightening these connections must be from the front, without the need for tools on the rear of the connection. Insulated horizontal and vertical bus barriers must be provided. Barriers must be fabricated from high-strength, glass-filled polyester resin.
- B. HORIZONTAL BUS: Horizontal bus minimum continuous amps rating must be as shown on the Drawings.
- C. VERTICAL BUS: Unless otherwise specified or shown, the vertical bus must be insulated and rated a minimum 300 amperes continuous.
- D. GROUND BUS: A 1/4-inch by 2-inch ground bus must be provided the full length of the motor control center. Ground bus must be located at the bottom of the motor control center. Provide a lug to terminate a bare 4/0 AWG copper ground conductors at each end of the ground bus.

2.06 WIRING

- A. GENERAL:
 - 1. Motor control centers must be provided with NEMA ICS 18 Class *II*, Type *B* wiring. All starter units must have terminal blocks for control wiring. Terminal blocks must be provided for power wiring for starters size 2 and smaller.
 - 2. Motor control centers must be provided with all necessary interconnecting wiring and interlocking. **When a MCC control section is specified on the drawings or schedules, wire directly to the relays or programmable controller's input/output modules as part of the interconnecting wiring.**
 - 3. Provide elementary and connection diagrams for each starter unit and an interconnection diagram for the entire motor control center.
- B. POWER WIRE: Power wire must be copper 90 degrees C insulated, sized to suit load; minimum power wire size must be No. 12 AWG copper stranded.
- C. CONTROL WIRE: Control wire must be No. 14 AWG stranded copper wire, rated 90 degrees C machine tool wiring (MTW) and UL listed for panel wiring.
- D. TERMINATIONS AND CABLE CONNECTIONS:
 - 1. Terminals: Control wiring must be lugged with ring-tongue or locking spade crimp type terminals made from electrolytic copper, tin-plated.
 - 2. Cable Connectors: Cable connectors for use with stranded copper wire, sizes No. 8 AWG to 1000 kCmil must be UL listed. Dished conical washers must be used for each bolted connection. Connectors must be reusable and must be rated for use with copper conductors. Incoming line and outgoing feeder compartments must be provided with crimp type lugs, 3M Company, Burndy Company, or equal.

- E. CONDUCTOR MARKERS: Markers used for identification must meet the requirements of **Section 26 05 00 – Electrical: Basic Requirements**.

2.07 MAIN AND FEEDER BRANCH CIRCUIT PROTECTION

- A. GENERAL: Main and feeder tap units must consist of fused disconnect switches or current limit circuit breakers, as specified or shown. Series ratings for overcurrent devices to meet specified short circuit withstand ratings is prohibited.
- B. FUSED DISCONNECT SWITCHES: NOT USED.
- C. CIRCUIT BREAKERS (THERMAL MAGNETIC):
 - 1. Thermal-magnetic circuit breakers must be molded case equipped with toggle type handle, quick-make, quick-break over center switching mechanism that is trip-free so that breaker cannot be held closed against short circuits and abnormal currents. The tripped position must be clearly indicated by breaker handle maintaining a position between "ON" and "OFF." All poles must open, close, and trip simultaneously.
 - 2. Circuit breakers used to feed automatic transfer switches provided under **Section 26 36 23 – Transfer Switches** that are rated in conjunction with the transfer switches to meet a coordinated withstand rating must be as identified by the transfer switch manufacturer to meet their requirements for the coordinated withstand rating.
- D. CIRCUIT BREAKERS (MAGNET ONLY): Magnetic circuit breakers must be molded-case equipped with toggle type handle, quick-make, quick-break over center switching mechanism that is trip-free so that breaker cannot be held closed against short circuits and abnormal currents. The tripped position must be clearly indicated by breaker handle maintaining a position between "ON" and "OFF." All poles must open, close, and trip simultaneously. Minimum short circuit capacity must be **42,000** amperes symmetrical.

2.08 MOTOR STARTER UNITS

- A. GENERAL: Motor starter units must be combination type with contactor and fused disconnect switch, thermal magnetic circuit breaker, or motor circuit protector, and bimetallic type overload unit as indicated on the drawings or specified in the MCC.
- B. FUSED DISCONNECT SWITCHES: NOT USED.
- C. MOTOR CIRCUIT PROTECTORS: The molded case motor circuit protector (MCP) must operate on the magnetic trip principle with a current sensing coil in each of the three poles to provide an instantaneous trip for short circuit protection. The trip setting must be adjustable from 700 to 1300 percent of the motor full load amperes from the front of the MCP. The motor circuit protector must be set at its lowest position at the factory.
- D. CONTROL TRANSFORMERS:

1. Each control transformer must be rated 480/240-120V, single phase, 2-wires, 60 Hertz. The transformer must be sized for the load it feeds but must not be less than the minimum ratings as follows unless noted otherwise on the Drawings:

NEMA starter size	Minimum transformer voltage-ampere rating
1	100
2	150
3	200
4	300

2. Each control transformer must be provided with time-delay, slow-blow secondary fuse rated to interrupt 10,000 amperes short circuit at 250 volts AC. Two primary fuses rated to interrupt 200,000 amperes at 600 volts must be provided on all starters.
3. Fuse holder for secondary fuse must be drawout indicating type and mounted on the door of the compartment. Fuse holders for primary fuses must be fuse clips with full barriers between fuses.

E. CONTACTORS:

1. Unless otherwise specified or shown, contactors must be full voltage, 3-pole, 600 volt AC, NEMA Size-1 minimum. Contacts must be double break, silver-cadmium oxide, and weld resistant. Contacts must be isolated to prevent arcing. Coils and magnets must be capable of being removed or replaced without special tools. IEC contactors are prohibited.
2. Reversing, multispeed, and reduced voltage starters must have additional contactors, overload relays, and auxiliary relays as required, and must have mechanically interlocked contactor coils to prevent simultaneous engagement.

F. AUXILIARY CONTACTS: Contactors must be equipped with auxiliary contacts. Auxiliary contacts must be wired out to terminal blocks. Each contactor must be equipped with contact quantity and configuration shown on the drawings. The minimum quantity and configuration of contacts is as follows:

1. Two normally open and two normally closed electrically isolated auxiliary contacts suitable for 24VDC programmable controller inputs, rated minimum 3A resistive at 28VDC.
2. Two normally open and two normally closed electrically isolated auxiliary contacts rated 10A at 120VAC.

G. OVERLOAD RELAY: All motor starters must include bimetallic thermal overload relays with local manual overload reset. Overload relays must monitor all three phases individually for current and equipped with auxiliary contacts as shown on the drawings.

H. TERMINAL BLOCKS:

1. Terminal blocks must be screw type rated 600 volts; 20 amperes for control wiring and 30 amperes power wiring with starters Size 3 and larger must terminate the power leads directly to the contactor.
2. The number of terminal blocks must be specified on the drawings. Terminal blocks must be provided with integral marking strips and must be permanently marked with the conductor number as specified on the drawings. Internal wiring must be connected on one side of the terminal block; outgoing conductors must be connected to the other side.

2.09 TRANSIENT VOLTAGE SURGE SUPPRESSOR

- A. Surge suppression devices must comply with **Section 26 43 13 – Low Voltage-Surge Protection Devices (SPD)** and the following:
1. Provide a factory selected transient surge suppressor rated for each control relay, motor starter, and power contactor encapsulated in a small module and mounted directly to the starter, contactor, or relay coil.

2.10 VARIABLE FREQUENCY DRIVES

- A. Variable Frequency Drives must be integral with MCC and comply with **Section 26 29 23 – Variable Frequency Drive Motor Controllers.**

2.11 MISCELLANEOUS

- A. GENERAL:
1. Control devices such as pushbuttons, selector switches, indicating lights and overload reset pushbuttons must be mounted on the unit compartment door or as specified on the Drawings.
 2. The control devices must comply with the requirements of **Section 26 27 15 - Miscellaneous Electrical Devices.**
- B. ELAPSED TIME INDICATOR: Where specified, the elapsed time indicator must be as specified in **Section 26 27 15 - Miscenallaneous Electrical Devices.** The indicator must be mounted on the unit compartment door.
- C. NAMEPLATES: Nameplates must be provided in accordance with the requirements of **Section 26 05 00 – Electrical: Basic Requirements.** Nameplates must be provided for all cubicles and compartments and identify the feed/load per NEC. A Nameplate must be provided identifying the motor control center. Provide equipment tag numbers and descriptions as shown on the Drawings.

2.12 DRY-TYPE TRANSFORMERS

- A. Dry-type power transformers must be **integral in MCC and comply with Section 26 22 00 - Low Voltage Transformers.**

2.13 PHASE FAIL MONITOR RELAY

- A. Three Phase Monitor Relays must be Square D MPD series, Allen Bradley, or approved equal.
 - 1. Voltage and rating as indicated on Drawings.
- B. Three Phase monitor and interposing relays must be installed in a dedicate compartment as shown on the drawings.
- C. Provide interlock circuits and interposing relays for control and monitors, see **Section 26 27 15 – Miscellaneous Electrical Devices.**

2.14 LIGHTING PANEL: PANELBOARD

- A. Panelboard must be integral mounted to MCC and comply with Specification **Section 26 24 00 – Panelboards.**
- B. Provide AC current switches, split core, adjustable 0.25-150Amp sensing range with solid state switch SPST for ventilation equipment and sump pump as shown on the Drawing.
 - 1. Install the current switches in a dedicated 12” compartment.
 - 2. Manufacturer part NO. ACUAMP ASC150-AE-S, RIBXGTA-SCAL, or approved equal.

2.15 SPARE PARTS

- A. One set consisting of the following spare parts must be provided:
 - 1. 1 set each fuse size and type
 - 2. 10 indicating light bulbs

PART 3 – EXECUTION

3.01 GENERAL

- A. The motor control centers must be erected in accordance with the recommendations of the manufacturer and with the details specified herein.
- B. **Field wiring must meet the requirements of Article 3.02 of Section 26 05 19 - Low Voltage Electrical Power Conductors and Cables.** Cables larger than No. 6 AWG which hang from their vertical connections must be supported within 2 feet of the connection.
- C. The overload relays, must be coordinated by the Contractor with the heater elements selected based on the actual full load amperes of the motor connected to the starter and the requirements of the motor driven equipment.
- D. The motor circuit protectors must be adjusted by the Contractor to the lowest setting not causing false tripping.
- E. Install motor control centers level and plumb on a grating floor detailed and anchored as shown the Drawing and per the manufacturer’s installation instruction.

- F. Seismic anchorage must be per the manufacturer's installation instruction and **Section 26 05 29 - Hangers and Supports for Electrical System**.
- G. MCC conduit top or bottom entry where applicable for all interior circuits. Exterior circuits terminated to MCC must be via a drained junction box with drain and drip loops after penetrating through underground facility wall. Contractor may also submit an alternative conduit route to engineer for review on case by case basis. Conduit Side side entry of conduit to MCC is prohibited unless otherwise indicated.
- H. Program and configure the soft starters for pump soft start and stop operation to minimize hydraulic surge as specified in **Section 40 90 00 – Instrument Process Process Control Basic Requirements**.

3.02 FIELD TESTS

- A. Motor control centers must be tested in accordance with **Section 26 08 13 – Acceptance Testing**.

3.03 MANUFACTURER'S SERVICES

- A. Motor control centers and combo starters must be warranted to be free from defects in materials and workmanship for a period of 18 months from date of invoice from manufacturer.
- B. Provide a factory-trained representative at the site for the specified quantity and duration of the following activities. Specified durations do not include travel time to or from the Project Site.
 - 1. Training Sessions:
 - a. Procedures: **Section 01 75 00 – Commissioning and Site Acceptance**.
 - b. Provide a minimum of 2 hours of field training on the motor control center installation by qualified factory representative.
 - 2. Start up and Testing Assistance:
 - a. Provide a minimum of 4 hours of on-site support for startup and testing.
 - b. Configure Modbus RS-485 external communication network and include:
 - 1) Provide a minimum of 16 hours of support for on site network testing. Coordinate this site time with the Owner.
 - 2) Network Settings: Address, transmission rate, bus loss action, heartbeat interval, consumed path, and production path.
 - 3) Test each network data transfer in compliance with **Section 40 90 00 – Instrument Process Process Control Basic Requirements**.

3.04 COORDINATION WITH SHORT CIRCUIT AND ARC FLASH REQUIREMENTS

- A. Provide information required to support the short circuit and coordination and arc flash study specified in **Section 26 05 73 - Overcurrent Protective Device Coordination Study**.
- B. Install Arc Flash warning labels on MCC, panels, switches and all electrical devices required per NEC with level of PPE required.

END OF SECTION 26 24 19

SPECIFICATION SECTION 26 29 13
COMBINATION MOTOR STARTER

PART 1 – GENERAL

1.01 DESCRIPTION

- A. This Section specifies wall mounted combination motor starter, factory assembled or fabricated from UL-508A/689A certified shop. Combination motor starters specified herein, including all major components, must be furnished by a single manufacturer.
- B. Related Sections: The work of the following Sections is related to the work of this Section. Other Sections, not referenced below, may also be related to the proper performance of this work. It is the Contractor's responsibility to perform all the Work required by the Contract documents.
1. Section 01 33 10 - Submittals
 2. Section 26 05 00 – Electrical: Basic Requirements
 3. **Section 26 05 19 – Low Voltage Electrical Power Conductors and Cables**
 4. Section 26 08 13 – Acceptance Testing
 5. Section 26 27 15 - Miscellaneous Electrical Devices
 6. Section 26 28 00 – Overcurrent and Short Circuit Protective Devices
 7. Section 40 90 00 – Instrumentation for Process Control: Basic Requirements

1.02 REFERENCES

- A. This Section contains references to the most current version of the following documents. They are a part of this Section as specified and modified. Where a referenced document contains references to other standards, those documents are included as references under this Section as if referenced directly. In the event of conflict between the requirements of this Section and those of the listed documents, the requirements of this Section prevail.

Reference	Title
ANSI/NEMA ICS 1 & 2	Industrial Devices, Controllers, Assemblies, and General Requirements
NFPA 79	Electrical Standards for Industrial Machinery

1.03 SUBMITTALS

- A. Procedures: **Section 01 33 10 - Submittals.**
- B. A copy of this specification section, with addendum updates included, and all referenced and applicable sections, with addendum updates included, with each paragraph check-marked to indicate specification compliance or marked to indicate requested deviations from specification requirements. Check marks denote full compliance with a paragraph as a whole. If deviations from the specifications are indicated, and therefore requested by the Contractor, underline each deviation and denote by a number in the margin to the right of the identified paragraph. The Engineer is the final authority for determining acceptability of requested deviations. The remaining portions of the paragraph not underlined will signify compliance on the part of the Contractor with the specifications. The submittal must be accompanied by a detailed, written justification for each deviation. Failure to include a copy of the marked-up specification sections, along with justification(s) for any requested deviations to the specification requirements, with the submittal is sufficient cause for rejection of the entire submittal with no further consideration.
- C. Layout and elevation drawings of starter enclosure depicting equipment arrangement and dimensions including areas of permissible conduit and cable entries. A list of material and components must accompany the layout drawings to include:
1. Starter and component schedule indicating size and type of protection including thermal bi-metallic elements rated for connected nameplate full load current.
 2. Motor circuit protector including interrupting and/or withstanding the specified short circuit current condition and continuous current rating.
 3. Unit schematic/elementary wiring diagram depicting electrical identification of wiring and terminals where field devices or remote control signals are to be terminated as indicated on the Drawings and/or loop descriptions.
- D. Operation and Maintenance Manuals
1. Cut sheets of combination motor starters with installation instructions and all associated accessories clearly indicated.
 2. Manufacturer's product data including ratings, voltages, and poles.
 3. Manufacturer's instructions for configuring, data registers and programming remote network data exchange using Modbus RS-485 interface connectivity for all modbus devices.

PART 2 – PRODUCTS

2.01 MANUFACTURERS

- A. Subject to compliance with the Contract documents and acceptable manufacturers are:
1. **Square D, Allen Bradley, or approved equal.**

2. Submit request for substitution in accordance with Section 01 33 10 – Submittals.

2.02 BASIC STARTER DESCRIPTION

- A. Combination motor starters must be rated in accordance with NEMA sizes and horsepower ratings as indicated on the Drawings and must be UL listed.
- B. Contactor contacts must be silver alloy, double break, and allow for inspection on NEMA Size 00 through 4 without the use of tools. They must be replaceable without removing the line, load, or control wiring from the starter, and replaceable without removing the starter from the enclosure.
- C. Contactor coils must be the encapsulated type and replaceable on NEMA Size 00 through 4 without the use of tools. They must be replaceable without removing the line, load, or control wiring from the starter, and replaceable without removing the starter from the enclosure.
 - 1. Operating coils are 120 volts and must be pressure molded and designed so that accidental exposure to excessive voltage up to 480 volts will not damage the coil. The starter design must also be definitely open and not freeze in the closed position when coil fails due to overvoltage condition.
- D. Overload protection must be provided by thermal bi-metallic overload relay for three-leg overload protection.
 - 1. Thermal overloads must be Class 20 bi-metallic type with interchangeable heaters. They must be provided with plus or minus 10 percent trip point adjustment and be ambient compensated. They must have visual trip indication and be ambient insensitive within the specified operating temperature range. They must have a reset mechanism that resets on the upstroke only. They must have a manual weld-check which checks the overload contacts for welding. They must provide 1 Normally Closed plus 1 Normally Open isolated contact.

2.03 CONSTRUCTION

- A. CONSTRUCTION:
 - 1. Standards: UL 508 and NEMA ICS2 or 250.
 - 2. Totally enclosed wall mounted assemblies.
 - 3. Fabricate of not less than 12 GA steel with 14 GA steel doors in standardized units with 40 mil PVC exterior coating.
 - 4. Enclosure must be NEMA 12 or 3R as indicated on the Drawings, dust-tight and drip-proof, gasketed material round all doors and cutouts.
 - a. Unit door: Formed round corners and rolled edges.
 - b. Minimum of 2 hinges or continuous piano hinge.

- c. Held closed by means of captive fasteners.
 - d. Use oversize enclosures as needed to provide additional panel space for installation of relays, fuse and terminal blocks, power monitors, and other auxiliary components.
5. Operating handle:
- a. With the unit stabs engaged and door closed the handle mechanism allows complete ON/OFF control of the unit disconnect and clear indication of the disconnect status. Circuit breaker and MCP operators includes a separate TRIPPED position.
 - b. Mechanical interlock to prevent the opening of the door when the disconnect is in the ON position with a defeater mechanism.
 - c. Mechanical interlock to prevent the placement of the disconnect in the ON position with the door open with a defeater mechanism.
 - d. Non-defeatable interlock to prevent the installation or removal of a unit unless the disconnect is in the OFF position.
6. Control Power Transformer required with 480 volt starter:
- a. 120V secondary.
 - b. Fused on primary and secondary side.
 - c. Sized for 140 percent of required load.
7. Power Monitor Device with CT's and PT's made by Schneider Electric P/N PM5000 series or PM500 by Allen Bradley, or approved equal.
- a. Capable of Serial Modbus RS-485 connectivity.
 - b. Capable of display four values on screen at the same time and a summary screen for user to take a snapshot of the system power.
 - c. Capable of capture waveform of the voltage and current channels. Capture waveforms store in internal no-volatile memory, 128 digitally sampled data points for each cycles.
 - d. Capable of perform Min, Max, Average, Peak, True RMS values in real-time readings, energy readings, and demand readings of the basic following parameters:
 - 1) Current (per phase, N (calculated), 3-phase Avg, % unbalance)
 - 2) Voltage (L-G per phase Avg, L-L 3-phase Avg, L-N per phase Avg, 3-phase Avg % unbalance)
 - 3) Ral, Reactive, and apparent power (per phase, 3-phase total)

- 4) True and Displacement Power Factor (per phase, 3-phase total)
 - 5) Date/time stamps of readings.
 - e. Standard, off the shelf factory assembled combination motor starter does not come with power monitor meter. Contractor must coordinate with factory or UL-508A certified shop to assemble power meter on the enclosure door. Upsize the enclosure as needed to fit all required components per design schematic/wiring diagram as indicated on the Drawings. Use cable harness and tie wraps to neatly bundle and secure interior wiring per UL 508 and NEMA ICS 2 standards.
8. Externally mounted overload relay pushbutton.
 9. Finish: Rust inhibited primer and manufacturer's standard paint inside and out.
 10. Provide ample unrestricted space for conduit entry from the bottom.
 11. Wiring: NEMA ICS 3 Class II, Type B-D.
 12. Fault Current Withstand Rating: minimum 18 kAIC at voltage indicated on the Drawings or equal to the rating of the electrical panel from which it is fed.
 13. Overcurrent and Short Circuit Protective Devices: See **Section 26 28 00 - Overcurrent and Short Circuit Protective Devices** for requirements.
 14. Provide a factory selected transient surge suppressor rated for each control relay, motor starter, and power contactor encapsulated in a small module and mounted directly to the starter, contactor, relay coil, etc.

2.04 FULL VOLTAGE NON-REVERSING STARTER

- A. NEMA Size 00 through 4 must be consisting of contractor with coil voltage of 120 volts at 60 Hz, overload relay, and disconnecting means.
- B. Disconnecting means must be provided with an external operating handle mounted in the flange of the enclosure which has a means to lock the handle in the off position and constructed as specified in **Article 2.03** of this Section.
- C. Starter must include the following requirements:
 1. Control power transformer as required in **Article 2.03**.
 2. Auxilliary contacts: minimum 1 normally open and 1 normally closed, or as shown on control wiring diagram Drawing.
 3. Elapsed time meter where required and phase failure relay with under-voltage protection interlocked with control starter as shown on the Drawings.
 4. Operator push bottoms with Hand-Off-Auto keyed selector switch where required on the Drawings.
 5. Provision for pump jog switch connectivity as specified on the Drawings and in **Section 26 27 26 - Wiring Devices**.

6. Standard indicating lights must be 30.5mm heavy-duty 120Vac or 24Vdc push-to-test LED type with NEMA rating to match enclosure type. Color code and numbers as shown on the Drawings.
7. Unless otherwise indicated on control wiring diagram Drawings, provide control relay with 2 normally open and 2 normally closed 10A rated contacts, pneumatic time delay ON and OFF relays adjustable from 1 to 60 seconds, 12 point terminal strip for field input/output control wiring, space heater with normally closed auxiliary contact, DIN Rail mounting for all control devices.

2.05 MISCELLANEOUS

A. GENERAL:

1. Control devices such as pushbuttons, selector switches, indicating lights and overload reset pushbuttons must be mounted on the unit compartment door or as specified on the Drawings.
2. The control devices must comply with the requirements of **Section 26 27 15 - Miscellaneous Electrical Devices**.

B. ELAPSED TIME INDICATOR: Where specified, the elapsed time indicator must be as specified in **Section 26 27 15 - Miscellaneous Electrical Devices**. The indicator must be mounted on the unit compartment door.

C. NAMEPLATES: Nameplates must be provided in accordance with the requirements of **Section 26 05 00 – Electrical: Basic Requirements**. Nameplates must be provided for all cubicles and compartments and identify the feed/load per NEC. A Nameplate must be provided identifying the motor control center. Provide equipment tag numbers and descriptions as shown on the Drawings.

2.06 PHASE FAIL MONITOR RELAY

A. Three Phase Monitor Relay must be Square D MPD series, Allen Bradley, or approved equal.

1. Voltage and rating as indicated on the Drawings.

B. Three Phase monitor relay and interposing relay must be installed in a separated panel or enclosure as indicated on the Drawings.

1. Provide electrical interlock wiring for each combination starter as indicated on the Drawings.

C. Provide interlock circuits and interposing relays for control and monitors, see **Section 26 27 15 – Miscellaneous Electrical Devices**.

2.07 SPARE PARTS

- A. One set consisting of the following spare parts must be provided:
 - 1. 1 set of each fuse size and type
 - 2. 2 sets of indicating light bulbs

PART 3 – EXECUTION

3.01 GENERAL

- A. Mount combination motor control equipment in accordance with the recommendations of the manufacturer and with the details specified herein.
- B. **Field wiring must meet the requirements of Article 3.02 of Section 26 05 19 – Low Voltage Electrical Power Conductors and Cables.** Cables larger than No. 6 AWG which hang from their vertical connections must be supported within 2 feet of the connection.
- C. The overload relays, must be coordinated by the Contractor with the heater elements selected based on the actual full load amperes of the motor connected to the starter and the requirements of the motor driven equipment.
- D. The motor circuit protectors must be adjusted by the Contractor to the lowest setting not causing false tripping.
- E. Seismic anchorage must be per the manufacturer's installation instruction and **Section 26 05 29 - Hangers and Supports for Electrical System.**
- F. Program and configure the equipment per operation as specified in **Section 40 90 00 – Instrumentation for Process Control: Basic Requirements.**

3.02 FIELD TESTS

- A. Motor control equipment must be tested in accordance with **Section 26 08 13 – Acceptance Testing.**
- B. Provide equipment start up and testing assistance and training:
 - 1. Procedures: **Section 01 75 00 – Commissioning and Site Acceptance.**

END OF SECTION 26 29 13

SPECIFICATION SECTION 26 29 23

VARIABLE FREQUENCY DRIVE MOTOR CONTROLLERS

PART 1 – GENERAL

1.01 DESCRIPTION

- A. This Section specifies preassembled, combination Variable Frequency Drive (VFD) rated 600 volts for speed control of three phase 10 Hp and larger squirrel-cage induction motors and/or factory assembled 600 volt motor control centers (MCCs) with VFD applications. The VFD system specified herein must contain all components to meet the performance, safety, and certification criteria and be furnished by a single manufacturer.
- B. Related Sections: The work of the following Sections is related to the work of this Section. Other Sections, not referenced below, may also be related to the proper performance of this work. It is the Contractor's responsibility to perform all the Work required by the Contract documents.
1. Section 01 33 10 – Submittals
 2. Section 01 75 00 – Commissioning and Site Acceptance
 3. Section 26 05 00 – Electrical Basic Requirements
 4. Section 26 05 73 - Overcurrent Protective Device Coordination Study
 5. Section 26 08 13 – Acceptance Testing
 6. Section 26 27 15 - Miscellaneous Electrical Devices

1.02 REFERENCES

- A. This Section contains references to the following documents. They are a part of this Section as specified and modified. Where a referenced document contains references to other standards, those documents are included as references under this Section as if referenced directly. In the event of conflict between the requirements of this Section and those of the listed documents, the requirements of this Section prevail.

Reference	Title
ANSI/NEMA ICS 1	Industrial Control Systems: General Requirements
ANSI/NEMA ICS 18	Motor Control Centers
IEEE 519	Standard Practices and Requirements for Harmonic Control in Electrical Power System
IEEE C62.41	Recommended Practices for Surge Voltages in Low-Voltage AC Power Circuits

Reference	Title
NFPA 70	National Fire Protection Association and Electrical Code Articles 430
NEMA 250	National Electrical Manufacturer Association: Enclosures for Electrical Equipment

- B. Codes and Standards: VFD System and all components must be Underwriters Laboratory listed to UL 508A and 508C and NEMA ICS 7 standards.

1.03 SUBMITTALS

- A. Procedures: **Section 01 33 10 - Submittals.**
- B. A copy of this specification section, with addendum updates included, and all referenced and applicable sections, with addendum updates included, with each paragraph check-marked to indicate specification compliance or marked to indicate requested deviations from specification requirements. A check mark denotes full compliance with a paragraph as a whole. If deviations from the specifications are indicated, and therefore requested by the Contractor, underline each deviation and denote by a number in the margin to the right of the identified paragraph, referenced to a detailed written explanation of the reasons for requesting the deviation. The Engineer is the final authority for determining acceptability of requested deviations. The remaining portions of the paragraph not underlined will signify compliance on the part of the Contractor with the specifications. Failure to include a copy of the marked-up specification sections, along with justification(s) for any requested deviations to the specification requirements, with the submittal is sufficient cause for rejection of the entire submittal with no further consideration.
- C. Elementary and wiring diagrams as required in **Article 2.07** of this Section, in accordance with standards required in **Article 1.02** references.
- D. Time current curves for protection devices including interrupting, withstand, and continuous/continuous current ratings.
- E. Identification and location of closest authorized service organization and a list of all major components include data sheets and publication/certifications.
- F. Harmonic analysis report with specific harmonic analysis at each Point of Common Coupling per Harmonic Protection Requirement Article and information used in the analysis in **Section 26 05 73 – Overcurrent Protective Device Coordination Study.**
- G. Nameplate information include VFD amp frame size, rated input/output current, short circuit current, motor feeder and VFD maximum cable length and type (shielded), field wiring terminals for power, grounding, and control connections.
- H. Elevation and layout drawings of VFD enclosures depicting areas of permissible heat dissipation and proper cooling space required around the unit. A list of material and components must accompany the layout drawings.
- I. Manufacturer's certification and calculations that the equipment complies with the seismic requirements, **Section 26 05 00 - Electrical: Basic Requirements**, and this Section.

- J. Certified factory test report confirming compliance with specified requirements within this Section. Submit a certified field test report showing:
 - 1. Each VFD is operational with its driven equipment motor compatible.
 - 2. VFD responds correctly to the input control signals and to critical frequencies that drive system is set to lockout at these frequencies.
- K. Manufacturer's certifications for installation instructions, operation and maintenance manuals, and items specified in the following:
 - 1. Manufacturer's written instructions for testing and adjusting thermal-magnetic circuit breaker, motor-circuit protector trip setting, and setting load current for overload relay suit actual motor to be protected.
 - 2. Manufacturer's written instructions for testing, configuring and reprogramming microprocessor control modules.
 - 3. Manufacturer's written instructions for setting field-adjustable timers, controls, and status and alarm registers for remote network data exchange via SCADA serial Modbus communication.
- L. Manufacturer's standards for VFD test and troubleshooting procedures with a cross-reference between symptoms and corrective recommendations.

1.04 WARRANTY

- A. Special warranty: The manufacturer agrees to repair or replace VFD system and components that fail in materials or workmanship for 2 years from Substantial Completion Date.

1.05 QUALITY ASSURANCE

- A. General Referenced Standards and Publications are listed in **Article 1.02**, but shall not be limited to identification of listed qualifications:
 - 1. VFD and associated optional components must be listed for the application purposes and labeled by UL, ETL, or Nationally Recognized Testing Laboratory (NRTL) and agencies as defined by OSHA regulations. Other independent testing agency must be acceptable to the inspection Authority Having Jurisdiction (AHJ).
 - 2. Jurisdiction for this project is the City of Seattle Department of Construction and Inspections (SDCI). Contractor must verify that equipment provided is in conformance with the listing guideline per SDCI requirements.
 - 3. Where listed drives and other components are installed in a common enclosure, the assembly shall be listed and labeled per UL 508 and UL 508A or equivalent NRTL standards. The entire assembly must be tested by a certified member of NETA or NRTL prior to shipment.
 - 4. VFD supplier must maintain an authorized service organization within 100 miles of the Project Sites.

- B. The VFD system must be factory tested and certified at the manufacturer floor and all functional test required at the place of final assembly where drives and other components are installed in a common enclosure prior to shipment. The costs of shop and factory tests must be included in the Base Bid.
- C. The VFD manufacturer must review drive specification section and coordinate electrical design plan to provide the best solution for the harmonic and motor protection included, but not be limited to, all aspects of power distribution system, upstream available short circuit current, feeder impedance, common coupling of linear and non-linear load, motor feeder cable type, available floor space and outlined herein:
 - 1. Provide control as indicated on the electrical drawings and specified in **Section 40 90 05 - Control Loop Descriptions**.
 - 2. Provide the hardware and software necessary to allow the VFD to control the driven equipment motor include, but are not limited to, analog and digital interface modules, communication interface modules, switches and display modules.
 - 3. Coordinate equipment dimensions with space requirements as indicated on Drawings and verify control devices furnished with the driven equipment as such vibration switches, thermal and leak detector sensors, etc.

1.06 DELIVERY, STORAGE, AND HANDLING

- A. The Contractor must coordinate the shipping of equipment with the manufacturer and store the equipment in a clean and dry space at an ambient temperature range of -25^oc to 55^oc.
- B. The Contractor must protect the equipment from dirt, water, and construction debris.

PART 2 – PRODUCTS

2.01 ACCEPTABLE MANUFACTURERS

- A. Drive system subjects to compliance with the Contract Documents, and the acceptable manufacturers are as listed:
 - 1. Schneider Electric, Square D – Model Altiva 660 and 630 **AC Drives**.
 - 2. **Rockwell Automation, Inc; Allen-Bradley - Model PowerFlex 753 AC Drives.**
 - 3. **Or approved equal.**

2.02 VARIABLE FREQUENCY DRIVE SYSTEM

- A. General Requirement: VFDs, where installed in motor control center (MCC) construction or separately-mounted must constitute a complete combination motor controller per NFPA 70, Article 430. Drive manufacturer and the Contractor must coordinate to review design requirements and application to provide the best solutions for the harmonic filter, noise suppression, and motor protection. Other VFD requirements include:
 - 1. VFD is listed as UL508C and complies with NEMA ICS 7, ICS 61800-2.
- B. VFD system must be consisting of power converter that employs pulse-width-modulated inverter factory built and tested in an enclosure with integral disconnecting means, overcurrent, and overload protection; listed and labeled by an NRTL or UL508C as a complete unit; arranged to provide sufficient air circulation, self-protection, and variable-speed control of one three-phase induction motor by adjusting output voltage and frequency.
 - 1. Units suitable for operation of NEMA MG 1, Design A and Design B motors, as defined by NEMA MG 1, Section IV, Part 30, "Application Considerations for Constant Speed Motors Used on a Sinusoidal Bus with Harmonic Content and General Purpose Motors Used with Adjustable-Voltage or Adjustable-Frequency Controls or Both".
 - 2. Units suitable for operation of inverter-duty motors as defined by NEMA MG 1, Section IV, Part 31, "Definite-Purpose Inverter-Fed Polyphase Motors".
 - 3. Listed and labeled for integrated short-circuit current (withstand) rating by an NRTL acceptable to authorities having jurisdiction.
- C. VFD Ratings match submitted load: Centrifugal pumps direct connection to the motors with a maximum speed of 1200 rpm.

2.03 PERFORMANCE AND DESIGN REQUIREMENTS

- A. Application:
 - 1. VFD(s) shall be of sufficient capacity and shall provide a quality of output waveform for stepless motor control from 10 to 100 percent of base speed of the driven equipment.
 - 2. VFDs shall be compatible with:
 - a. Inverter duty induction motors.
 - 3. VFDs shall be suitable for Constant Torque (CT) or Variable Torque (VT) applications:
 - a. VFD manufacturer shall coordinate with the manufacturer of the driven equipment to identify CT and VT applications.
 - 4. VFDs shall be designed to operate successfully under the following site conditions:
 - a. Ambient:
 - 1) Temperature: 0-40 DegC.
 - 2) 95 percent non-condensing relative humidity.
 - b. Elevation: Less than 3,300 FT above MSL.

- c. Power supply characteristics:
 - 1) 480Vac, 3 PH, 60 Hz, 3 wire, (+/- 10 percent).
 - 2) Effectively grounded.
- B. Ratings and Performance Specifications:
 1. Voltage rating:
 - a. Nominal: 480 Vac, 3 PH, 60 Hz.
 - b. Range for continuous full load operation: +/-10 percent of nominal.
 - c. Voltage imbalance tolerance for full load operation: 3 percent minimum.
 2. Current ratings:
 - a. Continuous:
 - 1) As required in the VFD ratings listed above.
 - b. Short-term overload:
 - 1) VT: 110 percent for 1 minute.
 - 2) CT: 150 percent for 1 minute.
 - 3) Permissible for 1 minute every 10 minutes continuously.
 - c. Short circuit:
 - 1) 42KA A RMS SYM, minimum.
 - 2) Where a short circuit rating is not indicated or specified for individual VFDs, each VFD shall have a rating not less than indicated on the Drawings for the MCC, switchboard or panelboard the VFD is supplied from.
 - 3) Where specified short circuit rating indicates additional input impedance is required to protect semiconductors, provide input AC line reactors, whether required to meet harmonic performance specifications or not.
 3. Efficiency:
 - a. 97 percent, minimum, at full speed and full load.
 - b. 93 percent, minimum at 1/2 speed and full load.
 4. Displacement power factor:
 - a. 95 percent, minimum from 50 percent to 100 percent speed and load.
 5. Efficiency and power factor criteria apply from the input terminals to the output terminals of the VFD alone, excluding losses of input and output power circuit accessories.
 6. Frequency drift:
 - a. +0.5 percent of set frequency.
 7. Speed regulation (motor dependent): 3 percent.
 8. Speed range: 10:1.

9. Control type:
 - a. Volts/Hertz ratio; constant over the entire operating range of the VFD except:
 - 1) When operating under voltage boost.
 - 2) At frequencies over 60 Hz.
- C. Operational Features:
 1. Insensitive to input phase sequence.
 2. Continued operation with momentary voltage dips of 25 percent of rated voltage, or single phase condition: 4 second, minimum.
 3. Controls power loss ride-through: 500 msec, minimum.
 4. Electronic reversing.
 5. DC injection braking.
 6. Anti-windmilling: Synchronization of VFD starting frequency with spinning or coasting load, forward or reverse.
 7. Critical frequency band lockout:
 - a. Minimum of three 3 settings.
 - b. Adjustable bandwidth, 1 - 5 Hz.
 8. Capable of operating without the motor connected for start-up and troubleshooting.
- D. The VFD shall be provided with the following minimum user-programmable parameters:
 1. Carrier frequency.
 2. Independent maximum and minimum speeds for forward and reverse operation.
 3. Start frequency and hold time.
 4. Independent linear acceleration and deceleration time.
 5. Analog speed control, 4-to-20ma input
 6. Preset "jog" speed.
 7. 3 critical frequency bands.
 8. 1 preset speed selectable by logic input. Shall override 4-to-20ma input.
 9. Volts/Hertz ratio.
 10. Voltage boost, magnitude and frequency range.
 11. Process controller gain, offset and bias.
 12. Current limit.
 13. Overcurrent pickup.
 14. Overcurrent delay.

15. Ground fault pickup.
 16. DC injection level and time.
- E. The VFD shall be designed such that the power circuit components are fully protected from line side disturbances and load side faults:
1. General:
 - a. Shutdown conditions associated with supply circuit conditions which can be corrected external to the VFD-motor system shall be provided with automatic reset, with shutdown cause logged in memory:
 - 1) Input under voltage.
 - 2) Input over voltage.
 - 3) Input under frequency.
 - 4) Input over frequency.
 - 5) Input Phase loss.
 - 6) DC Bus under voltage.
 - b. Shutdown conditions which indicate overload or fault within the VFD and the output circuit. The motor shall require local manual reset at the VFD requiring operator intervention:
 - 1) Motor & VFD overtemperature.
 - 2) Blown fuse.
 - 3) Component failure.
 - 4) Overload.
 - 5) Short circuit.
 - 6) Ground fault.
 - 7) DC Bus over voltage.
 - 8) External safety input, motor thermal protection PTC or PT1000.
 - 9) Logic fault.
 - c. When automatic shutdown occurs, VFD shall restart immediately upon reset, whether automatic or manual.
 - d. VFD shall hold cause of trip data for a minimum of 4 shutdowns in memory:
 - 1) Data to be accessible through the keypad, local communication link, and remotely.
 2. Input protection:
 - a. Input circuit breaker with externally operable disconnect shall be shuntshunt trip and interlocked with drive fault signal.
 - 1) Fault current interrupting rating equal to or greater than the specified withstand rating of the VFD.
 - 2) Handle padlockable in the OFF position.

- b. Provide full protection for semiconductors integral to the VFD; units requiring current-limiting fuses or circuit breakers in the supply circuit are not acceptable.
- c. Incoming line transient suppression:
 - 1) 6000V peak per IEEE C62.41.
 - 2) Phase-to-phase and phase-to-ground protection.
- d. Sustained over voltage trip.
- 3. Internal protection:
 - a. Surge suppression and power device snubbers.
 - b. Power devices rated at 2.5 times line voltage.
 - c. Instantaneous over current trip.
 - d. DC bus over voltage trip.
 - e. Power device over temperature trip.
 - f. Control logic circuit malfunction trip.
- 4. Output protection:
 - a. Inverse-time overload trip:
 - 1) UL Class 10 characteristic.
 - b. Over voltage trip.
 - c. Over frequency trip.
 - d. Short circuit trip:
 - 1) Line to line and line to ground.
 - e. Ground fault trip.

2.04 OPERATOR AND REMOTE CONTROL INTERFACE

- A. Drive controls shall be microprocessor-based with on-board human machine interface and both local and remote digital communications capability:
 - 1. All monitoring and control functions, other than those shutdowns specified to be manual reset only, shall be available both locally and remotely.
 - 2. Drive parameters including input and output functions shall be configured to store in the drive memory over time and possible to extract via RS485 Modbus connectivity.
- B. Control circuits as indicated on Drawing or shall be 120 Vac:
 - 1. 120 Vac supplied by CPT in the VFD:
 - a. CPT shall have minimum additional capacity of 60 VA greater than that required by control devices.
 - b. CPT shall have 2 fuses on the primary side and 1 fuse on the secondary side.

- c. CPT shall have surge protection on the primary side independent of any other surge protection in the VFD.

C. Operator Interface:

- 1. Door mounted sealed keypad, membrane type with LED or LCD display:
 - a. Messages shall be in English and engineering units.
 - b. Drive operating parameters shall be programmable.
 - c. Menu driven.
 - d. Password security.
 - e. Display drive fault and diagnostic data.
 - f. Operating parameters, fault and diagnostic data maintained in non-volatile memory with historic log of fault and diagnostic data.
 - g. Gold plated plug-in contacts.
 - h. Default display must be configurable to show motor operating parameters: voltage, speed, current, power, etc.
 - 1) Install a separate power meter to displace motor operating parameters as such for every motor controller if the VFD keypad is unable to display the motor information on its default menu.
 - 2) Power meter must be the same VFD manufacturer: SchneirderSchneider Electric PM5560 seriresseries, Allen Bradley PowerMonitor 5000, or approved equal.
- 2. Provide interlock control with motor disconnect (Meltric), including local indication and remote interface as incidatedindicated on Drawing:
 - a. Minimum panel indications:
 - 1) Ready.
 - 2) Run.
 - 3) Motor Connection Status.
 - 4) Fault.
 - b. Minimum control functions:
 - 1) Reset button.
- 3. Diagnostic indicators located externally on the face of the drive shall show the type of fault responsible for drive warning, shutdown or failure:
 - a. On occurrence of more than 1 condition, each shall be recorded or indicated by the diagnostics.

D. Remote Control Interface:

- 1. Local portable computer interface via RS232/RS242 serial communications port:
 - a. Capability to:
 - 1) Start-Stop VFD.

- 2) Control VFD Speed.
- 3) Access fault and diagnostic data.
2. Analog and discrete inputs:
 - a. Speed reference (setpoint) signal 4-20 mA DC.
 - b. Isolated process PID controller with user-programmable setpoint, gain, rate, reset and span for accepting a remote 4-20 mA DC process variable signal.
 - c. Drive Run input
 - d. Drive JOG input
 - e. Drive Enable input
 - f. Drive Pre-set run speed input
 - g. External thermocouple sensor
3. Analog and discrete outputs:
 - a. 4-20 mA DC output for remote speed indication, as a function of frequency, calibrated 0 to 100 percent.
 - b. Drive VFD FAULT contact.
 - c. Drive RUNNING contact.
 - d. Drive selector switch in AUTO status contacts.
 - e. Drive selector switch in HAND states contacts.
 - f. External alarm contact.
4. Contacts:
 - a. Contacts shall be rated 2 A inductive at 120 Vac.
 - b. All contacts shall be wired to field wiring terminal boards.
5. Drive shutdown on external fault input:
 - a. Provide isolated input for dry contact from external motor or system safety devices to cause immediate shutdown of VFD.
 - b. Safety shutdown to be operable in all operating modes of drive, including local operation from keypad.
 - c. Local safety switch, to driven equipment, auxiliary contact to lock-out VFD from running when safety switch is open.
6. Network communications capability:
 - a. Provide VFD with communication cards, protocols and required programming for digital communication of all VFD program and operational parameters to plant control system via both of the following:
 - 1) Ethernet IP.
 - 2) Serial ModBus RS-485.

- b. Refer to **Division 40** for additional requirements.

2.05 HARMONIC PROTECTION REQUIREMENTS

- A. All VFDs shall be capable of satisfactory operation from a source having voltage distortion and notch characteristics identified as acceptable for a “dedicated system” in IEEE 519 Table 10.2.
- B. With all VFDs operating under worst-case harmonic current conditions and the facility supplied from either or both the utility and generator sources, the VFDs shall not produce harmonic effects in excess of the following limits at any point of common coupling (PCC):
 1. Voltage distortion and notch characteristics: IEEE 519 Table 10.2 for General System.
 2. Current distortion: IEEE 519 Table 10.3 based on $ISC/IL < 20$.
- C. Point of Common Coupling (PCC) shall be considered:
 1. Building service entrance equipment or MCC.
 2. Each MCC, or panelboard supplying a VFD branch circuit.
- D. The Engineer has performed preliminary calculations based on typical VFD data which indicate that the minimum mitigation measures required to meet the specified harmonic criteria are 1 of the following topologies:
 1. 6-pulse rectifier topology with input line reactors and DC link reactors, minimum impedance 5 percent on drive kVA base.
- E. VFD manufacturer shall determine, for their proposed equipment, uncorrected harmonic distortion levels and mitigation techniques required to meet the specified limits and shall furnish the VFD types and all accessory items and equipment necessary to do so, whether specified herein or not.
- F. VFD manufacturer shall provide a harmonic analysis of the distribution system based on their proposed specific equipment characteristics and mitigation techniques confirming that the specified levels are not exceeded:
 1. Analysis shall be based on the methodology of IEEE 519 and IEEE 399.
 2. Power system data for analysis shall be taken from the electrical drawings and approved equipment submittals:
 - a. VFDs provided in a package with equipment specified elsewhere, shall be included in the analysis.
- G. Following start-up, with facility at full load operation, provide measurement of harmonic voltage, current and notch characteristics at each PCC according to the requirements of IEEE 519 Section 9:
 1. Values in excess of specified limits require correction by contractor and re-measurement.
 2. Provide certification of compliant measurements as part of Field Service Engineer’s final report.

2.06 MOTOR PROTECTION REQUIREMENTS

- A. The VFD shall produce a quality of output waveform adequate to allow the motor to produce rated torque at rated RPM continuously without exceeding the temperature rise given in NEMA MG 1, Table 31-2.
- B. Provide motor overload, short circuit and ground fault protection integral to drive electronics.
- C. The VFD shall not produce voltage spikes in excess of the following values at the motor terminals when operated with the feeder types shown on the Drawings and the actual installed feeder lengths:
 - 1. If unmitigated voltage peaks exceed the specified limits, provide output line reactors, filters, or other devices as required to meet the specified limits:
 - a. Inverter duty motors: 1280 V.
 - b. Rise time shall be greater than or equal to 0.1 microsecond.
 - c. Motor lead length and data shall be determined by the Contractor based on the actual routing of the conductors.
- D. Following start-up, provide measurement of peak voltage at the terminals of each motor, unless the lead lengths are 10 percent shorter than the manufacturers published literature for maximum lead length for the type of cable installed:
 - 1. Values in excess of specified limits require correction by contractor and re- measurement.
 - 2. Provide certification of compliant measurements as part of Field Service Engineer's final report.

2.07 EQUIPMENT CONSTRUCTION

- A. Fabrication and Assembly:
 - 1. Each VFD system shall be factory-assembled in an enclosure for mounting in the MCC, and shall utilize interchangeable plug-in printed circuit boards and power conversion components wherever possible:
 - a. Factory assembly shall be performed by the VFD manufacturer or authorized agent.
 - b. Systems fabricated or assembled in whole or in part by parties other than the VFD manufacturer or authorized agent will not be acceptable.
 - 2. Input Line Reactors and filters shall be mounted within the drive enclosure.
 - 3. Panel cooling fan shall be provided to run when drive is in operation, and exceeds operating temperature rating.
 - 4. Electrical interlock control as indicated shall be provided to allow only one unit operate at a time.

B. Wiring:

1. The wiring in the VFD shall be neatly installed in wire ways or with wire ties where wire ways are not practical:
 - a. Where wire ties are used, the wire bundles are to be held at the back panel with a screw-mounted wire tie mounting base.
 - b. Bases with a self-sticking back will not be allowed.
2. All plug-in contacts shall be gold-plated.
3. Provide terminal boards for all field wiring and inter-unit connections, including analog signals:
 - a. Provide terminals for shield continuity where required.
4. Terminal blocks shall be complete with marking strip, covers and pressure connectors:
 - a. Non-brittle, interlocking, track-mounted type.
 - b. Screw terminals will not be allowed.
 - c. A terminal for each conductor of external circuits plus 1 ground for each shielded cable.
 - d. For free-standing panels, 8 IN of clearance shall be provided between terminals and the panel base for conduit and wiring space.
 - e. Not less than 25 percent spare terminals shall be provided.
 - f. Terminals shall be labeled to agree with identification indicated on the suppliers submittal drawings.
 - g. Individually fuse each control loop or system and all fuses or circuit breakers shall be clearly labeled and located for easy maintenance.
5. All grounding wires shall be attached to the enclosure sheet metal with a ring tongue terminal:
 - a. The surface of the sheet metal shall be prepared to assure good conductivity and corrosion protection.
6. Wiring shall not be kinked or spliced and shall have markings on both ends or be color coded:
 - a. Markings or color code shall match the manufacturer's drawings.
7. With the exception of electronic circuits, all interconnecting wiring and wiring to terminals for external connection shall be stranded copper, type MTW or SIS, insulated for not less than 600 V, with a moisture-resistant and flame-retardant covering rated for not less than 90 DegC.

C. Nameplates:

1. All devices mounted on the face of the drive shall be provided with a suitable nameplate as specified in **Section in Section 26 05 00 – Basic Electrical Requirements**.

2. Push buttons, selector switches, and pilot lights shall have the device manufacturer's standard legend plate.
 3. Relays, terminals and special devices inside the control enclosure shall have permanent markings to match identification used on manufacturer's wiring diagrams.
- D. Painting: Enclosure, after being phosphate washed, shall be thoroughly cleaned and given at least 1 coat of rust-inhibiting primer on all inner surfaces prior to fabrication.

2.08 COMPONENTS AND ACCESSORIES

- A. Reactors:
1. Impedance: 5 percent.
 2. Continuous current: Not less than drive rating.
 3. Current overload: 150 percent for 1 minute.
 4. Insulation temperature rating: 180 Deg C.
 5. Copper windings.
 6. Saturation current rating: 3.5 to 5 times rated current.
 7. Hi-potential rating: 2500 Vac line to ground and line to line, for 1 minute.
 8. Noise reduction features:
 - a. Epoxy over cast coil.
 - b. Extra dips and bakes of varnish over continuous wound coil.

2.09 SOURCE QUALITY CONTROL

- A. Factory Tests:
1. Conduct all standard tests in accordance with NEMA and ANSI standards to ensure conformance to Specification requirements.
 2. Prior to final assembly:
 - a. Inspect incoming components.
 - b. Test and inspect power devices.
 - c. Circuit cards:
 - 1) Component and functional tests.
 - 2) Burn-in chamber or temperature cycling test.
 - 3) System test after burn-in or temperature cycling.
 3. After final assembly:
 - a. Continuity and insulation test of 480 power control circuits.
 - b. Drive tests:
 - 1) Burn-in complete drive at full load for 24 HRS.

- 2) Verify all auxiliary circuits operation.
- 3) Monitor output variables.
- c. Systems test:
 - 1) Provide inputs to field connections and simulate on-site operation.
 - 2) Test all auxiliary equipment.

2.10 MAINTENANCE MATERIALS

- A. Provide manufacturer's recommended renewable spare parts (e.g., power and control fuses).
- B. Spare parts utilized during pre-start-up or start-up and demonstration testing shall be immediately restocked, at no cost to the Owner.

PART 3 – EXECUTION

3.01 GENERAL

- A. The installer must examine the mounting surface, areas, and structures for compliance with the requirements of manufacturer's installation instructions, recommendations, and with the details specified herein.
 1. Reject or Proceed with installation only all conditions are satisfactory.
- B. **Field wiring must meet the requirements of Article 3.02 of Section 26 05 19 - Low Voltage Electrical Power Conductors and Cables.** Cables larger than No. 6 AWG which hang from their vertical connections must be supported within 2 feet of the connection.
 1. Comply with the requirements for identification specified in **Section 26 05 00 – Electrical Basic Requirements.**
- C. The overload relays where applicable must be coordinated by the Contractor with the heater elements selected based on the actual full load amperes of the connected motor's nameplate and the requirements of the motor driven equipment.
- D. The motor circuit protectors must be adjusted by the Contractor to the lowest setting not causing false tripping.
- E. Seismic anchorage must be per the manufacturer's installation instruction and **Section 26 05 29 - Hangers and Supports for Electrical System.**
- F. Program and configure VFD system for pump soft start, speed variation, and soft stop operation to minimize hydraulic surge as specified in **Section 40 90 05 – Control Loop Descriptions – Pump Station 20.**
- G. Comply with NECA 1 for all related electrical work.

3.02 FIELD TESTS

- A. VFD system must be tested in accordance with **Section 26 08 13 – Acceptance Testing**.

3.03 MANUFACTURER’S SERVICES

- A. Engage a factory-authorized service representative to perform startup service. All Work must be performed in the presence of the Engineer.
 - 1. Complete installation and startup checks per manufacturer’s instructions.
 - 2. Inspect for any defects in materials and workmanship void factory’s warranty.
 - 3. Adjust switches, auxiliary relays, time-delay relays, timers, and overload-relay pickup and trip ranges.
 - 4. Program and adjust the trip settings of instantaneous-only circuit breakers and thermal-magnetic circuit breakers with adjustable, instantaneous trip elements. Initially adjust to 6 times the motor nameplate full-load amperes and attempt to start motors several times, allowing for motor cool-down between starts. If tripping occurs on motor inrush, adjust settings in increments until motors start without tripping. Do not exceed 8 times the motor full-load amperes (or 11 times for NEMA Premium Efficient motors if required). Where these maximum settings do not allow starting of a motor, notify Engineer before increasing settings.
 - 5. Program and set keypad default display to show motor operating parameters such as current, voltage, power, frequency, and speed or as requested by owner
 - 6. Program to record external input thermocouple sensor and enable output relay when the input sensor exceeds the operational setpoint.
 - 7. Simulate VFD failures and demonstrate troubleshooting aids and procedures.
- B. Provide a factory-trained representative to demonstrate and train Owner’s maintenance personnel to setup, adjust, operate, preprogram, read alarm and event recording, display features, troubleshoot and maintain VFD.
 - 1. Training Session: Minimum of 2 hours on-site training
 - a. Procedures: **Section 01 75 00 – Commissioning and Site Acceptance**.

3.04 COORDINATION WITH SHORT CIRCUIT AND ARC FLASH REQUIREMENTS

- A. Provide information required to support the short circuit and coordination and arc flash study specified in **Section 26 05 73 - Overcurrent Protective Device Coordination Study**.
- B. Install Arc Flash warning labels on VFD per NEC with level of PPE required.

END OF SECTION 26 29 23

SPECIFICATION SECTION 40 05 01
GENERAL REQUIREMENTS FOR EQUIPMENT

PART 1 - GENERAL

1.01 DESCRIPTION

- A. Scope: This Section specifies general requirements which are applicable to all mechanical equipment. The Contractor is responsible for ensuring that all mechanical equipment meets the requirements of this Section in addition to the specific requirements of each individual equipment specification section.
- B. Equipment Lists: Equipment lists, presented in these Specifications and as specified on the Drawings, are included for the convenience of the Engineer and Contractor and are not complete listings of all equipment, devices and material required to be provided under this contract. The Contractor must prepare their own material and equipment takeoff lists as necessary to meet the requirements of this Project Manual.
- C. Related Sections: The work of the following Sections is related to the work of this Section. Other Sections, not referenced below, may also be related to the proper performance of this work. It is the Contractor's responsibility to perform all the work required by the Contract documents.
1. Section 01 11 00 - Summary of Work
 2. Section 01 33 10 - Submittals
 3. Section 01 75 00 - Commissioning and Site Acceptance
 4. Section 03 62 00 - Non-shrink Grouting
 5. Section 05 50 10 - Anchor Bolts and Anchors
 6. Section 26 05 00 - Electrical: Basic Requirements
 7. Section 40 07 00 - Mechanical Identification
 8. Section 43 21 13 - Vertical Centrifugal Non-Clog Sewage Pumps

1.02 REFERENCES

- A. This Section contains references to the documents listed below. They are a part of this Section as specified and modified. Where a referenced document cites other standards, such standards are included as references under this Section as if referenced directly. In the event of conflict between the requirements of this Section and those of the listed documents, the requirements of this section prevail.

Reference	Title
ABMA Std 9	Load Ratings and Fatigue Life for Ball Bearings
ABMA Std 11	Load Ratings and Fatigue Life for Roller Bearings
ANSI B1.1	Unified Inch Screw Threads (UN and UNR Thread Form)

Reference	Title
ANSI B1.20.1	Pipe Threads, General Purpose (Inch)
ANSI B16.1	Gray Iron Pipe Flanges and Flanged Fittings, (Classes 25, 125, and 250)
ANSI B18.2.1	Square and Hex Bolts and Screws (Inch Series)
ANSI B18.2.2	Square and Hex Nuts (Inch Series)
ANSI S2.19	Mechanical Vibration – Balance Quality Requirements of Rigid Rotors, Part 1: Determination of Permissible Unbalance, Including Marine Applications

1.03 SUBMITTALS

- A. See specification sections for individual pieces of equipment for required submittals.

1.04 QUALITY ASSURANCE

- A. Arrangement: The arrangement of equipment shown on the Drawings is based upon information available to the Owner at the time of design and is not intended to show exact dimensions conforming to a specific manufacturer. The Drawings are, in part, diagrammatic, and some features of the illustrated equipment installation may require revision to meet actual submitted equipment installation requirements; these may vary significantly from manufacturer to manufacturer. The Contractor must, in determining the cost of installation, include these differences as part of his Bid. Structural supports, foundations, connected piping, valves, and electrical conduit specified may have to be altered to accommodate the equipment actually provided. No additional payment will be made for such revisions and alterations.

- B. Unit Responsibility:

1. The Contractor must cause equipment assemblies made up of two or more components to be provided as a working unit by the unit responsibility manufacturer, where specified. The unit responsibility manufacturer must coordinate selection, coordinate design, and must provide all mechanical equipment assembly components such that all equipment components furnished under the specification for the equipment assembly, and all equipment components specified elsewhere but referenced in the equipment assembly specification, is compatible and operates reliably and properly to achieve the specified performance requirements. Unless otherwise specified, the unit responsibility manufacturer must be the manufacturer of the driven component equipment in the equipment assembly. The unit responsibility manufacturer is designated in the individual equipment specifications found elsewhere in this Project Manual. Agents, representatives or other entities that are not a direct division of the driven equipment manufacturing corporation will not be accepted as a substitute for the driven equipment manufacturer in meeting this requirement. The requirement for unit responsibility in no way relieves the Contractor of their responsibility to the Owner for performance of all systems as provided in **Section 01 11 00 - Summary of Work**.

2. The Contractor must ensure that all equipment assemblies provided for the project are products for which unit responsibility has been accepted by the unit responsibility manufacturer(s), where specified. Unit responsibility for related components in a mechanical equipment assembly does not require or obligate the unit responsibility manufacturer to warranty the workmanship or quality of component products not manufactured by them. Where an individual specification requires the Contractor to furnish a certificate from a unit responsibility manufacturer, the Contractor must furnish a letter from the unit responsibility manufacturer acknowledging the requirements of this Section as they relate to the equipment being submitted. The letter must be signed by a responsible party of the unit responsibility manufacturer. No other submittal material will be processed until the letter from the unit responsibility manufacturer has been received and has been found to be satisfactory. Failure to provide acceptable proof that the unit responsibility requirement has been satisfied will result in withholding approval of progress payments for the subject equipment *even though the equipment may have been installed in the work.*

- C. Testing Agency Listing For Electrified Equipment: Any equipment that utilizes electrical power must be listed for such use by a third party testing agency such as Underwriters Laboratories (UL) acceptable to the Authority Having Jurisdiction (AHJ) as defined in the National Electrical Code. The acceptability of third party testing agencies may vary by electrical product. The electrical authority having jurisdiction for this project will be the City of Seattle Department of Construction and Inspections (SDCI). It is the Contractor's responsibility to determine the product safety listing requirements by product type and to ensure that such listings are provided for that equipment.

PART 2 - PRODUCTS

2.01 FLANGES AND PIPE THREADS

- A. Flanges on equipment and appurtenances provided under this Section must conform in dimensions and drilling to ANSI B16.1, Class 125. Pipe threads must conform in dimension and limits of size to ANSI B1.1, coarse thread series, Class 2 fit. Where flanges are provided to interface pipe or equipment to existing flanges, the type, class, and facing of flange provided must match the existing flange. Do not joint flat faced flanges to raised face flanges.
- B. Threaded flanges must have a standard taper pipe thread conforming to ANSI B1.20.1. Unless otherwise specified, flanges must be flat faced. Where flat faced flanges are joined to existing raised face flanges, the raised face of the existing flange must be removed prior to connecting.
- C. Flange assembly bolts must be heavy pattern, hexagonal head, carbon steel machine bolts with heavy pattern, hot pressed, hexagonal nuts conforming to ANSI B18.2.1 and B18.2.2. Threads must be Unified Screw Threads, Standard Coarse Thread Series, Class 2A and 2B, ANSI B1.1. All bolts, nuts, and washers used for pipe and machine assembly must be hot dip galvanized per ASTM F2329, unless noted otherwise.

2.02 BEARINGS

- A. Unless otherwise specified, equipment bearings must be grease lubricated, ball or roller type, designed to withstand the stresses of the service specified. Each bearing must be rated in accordance with the latest revisions of ABMA Methods of Evaluating Load Ratings of Ball and Roller Bearings. Unless otherwise specified, equipment bearings must have a minimum L-10 rating life of 50,000 hours. The rating life must be determined using the maximum equipment operating speed.
- B. Grease lubricated bearings, except those specified to be factory sealed and lubricated, must be fitted with easily accessible grease supply, flush, drain and relief fittings. Extension tubes must be used when necessary. Grease supply fittings must be standard hydraulic alemite type.
- C. Oil lubricated bearings must be equipped with either a pressure lubricating system or a separate oil reservoir type system. Each oil lubrication system must be of sufficient size to safely absorb the heat energy normally generated in the bearing under a maximum ambient temperature of 60 degrees C and must be equipped with a filler pipe and an external level indicator gage.
- D. All bearings accessible to touch, and located within 7 feet measured vertically from floor or working level or within 15 inches measured horizontally from stairways, ramps, fixed ladders or other access structures, must either incorporate bearing housings with sufficient cooling to maintain surface temperature at 65 degrees C or less for continuous operation at bearing rated load and a 50 degrees C ambient temperature or must be provided with appropriate shielding that will prevent inadvertent human contact.

2.04 PUMP SHAFT SEALS

- A. General: Seals for wastewater pump shafts must be as specified in **Section 43 21 13 - Vertical Centrifugal Non-Clog Sewage Pumps.**

2.05 COUPLINGS

- A. Unless otherwise specified in the particular equipment sections, equipment with a driver greater than 1/2 HP, and where the input shaft of a driven unit is directly connected to the output shaft of the driver, must have its two shafts connected by a flexible coupling which can accommodate angular misalignment, parallel misalignment and end float, and which cushions shock loads and dampens torsional vibrations. The flexible member will consist of a tire with synthetic tension members bonded together in rubber. The flexible member will be attached to flanges by means of clamping rings and cap screws, and the flanges will be attached to the stub shaft by means of taper lock bushings which must give the equivalent of a shrunk-on fit. There must be no metal-to-metal contact between the driver and the driven unit. Each coupling must be sized and provided as recommended by the coupling manufacturer for the specific application, considering horsepower, speed of rotation, and type of service.
- B. Where torque or horsepower capacities of couplings of the foregoing type is exceeded, Thomas-Rex, Falk Steel Flex, or equal, couplings will be acceptable provided they are sized in accordance with the equipment manufacturer's recommendations and sizing data are submitted. They must be installed in conformance to the coupling manufacturer's instructions.

2.06 COUPLING GUARDS

Coupling guards must be furnished for all driven equipment. Guards must prevent hands or tools from readily reaching the drive shaft. Guards must be readily removable with standard mechanics' tools.

2.07 CAUTION SIGNS

Not Used.

2.08 GAUGE TAPS, TEST PLUGS AND GAUGES

Furnish in accordance with the Drawings.

2.09 NAMEPLATES

- A. Nameplates must be provided on each item of driven equipment and must contain the specified equipment name, tag number, and equipment number. Equipment nameplates must be engraved or stamped stainless steel and fastened to the equipment in an accessible and visible location with stainless steel screws or drive pins. Nameplates for other equipment must be as specified in **Section 26 05 00 – Electrical: Basic Requirements** and **Section 40 07 00 – Mechanical Identification**.

2.10 LUBRICANTS

- A. The Contractor must provide for each item of mechanical equipment a supply of the required lubricant adequate to last through the specified commissioning period. Lubricants must be of the type recommended by the equipment manufacturer and must be products of the Owner's current lubricant supplier. The Contractor must limit the various types of lubricants by consolidating them, with the equipment manufacturer's approval, into the least number of different types. Not less than 90 days before the date shown in the construction schedule for starting, testing and adjusting equipment (**Section 01 75 00 – Commissioning and Site Acceptance**), the Contractor must provide the Owner with three copies of a list showing the required lubricants, after consolidation, for each item of mechanical equipment. The list must show estimated quantity of lubricant needed for a full year's operation, assuming the equipment will be operating continuously.

2.11 ANCHOR BOLTS

- A. Anchor bolts must be designed for lateral forces for both pullout and shear in accordance with the provisions of **Section 05 50 10 - Anchor Bolts and Anchors**. Unless otherwise stated in the individual equipment specifications, anchor bolt materials must conform to the provisions of **Section 05 50 10 - Anchor Bolts and Anchors**.

2.12 SPARE PARTS

- A. Spare parts, wherever required by detailed specification sections, must be stored in accordance with the provisions of this Section. Spare parts must be tagged by project equipment number and identified by part number, equipment manufacturer, and subassembly component (if appropriate). Spare parts subject to deterioration, such as ferrous metal items and electrical components, must be properly protected by lubricants or desiccants and encapsulated in hermetically sealed plastic wrapping. Spare parts with individual weights less than 50 pounds and dimensions less than 2 feet wide, or 18 inches high, or 3 feet in length must be stored in a wooden box with a hinged wooden cover and locking hasp. Hinges must be strap type. The box must be painted and identified with stenciled lettering stating the name of the equipment, equipment numbers, and the words "spare parts." A neatly typed inventory of spare parts must be taped to the underside of the cover.

PART 3 - EXECUTION

3.01 GENERAL

- A. Installation of equipment accessories included in this Section must be as recommended by the equipment manufacturer unless otherwise specified in the individual equipment specification section.

End of Section 40 05 01

SPECIFICATION SECTION 40 05 072

Equipment Mounting

PART 1 - GENERAL

1.01 DESCRIPTION

A. Scope:

1. This Section specifies minimum requirements for rigid equipment mounts (baseplates and mounting blocks) and their installation on equipment pads. Completed equipment supports consists of equipment pads, equipment anchors, and rigid equipment mounts (baseplates or mounting blocks) set in grout.
2. Unless alternate requirements for equipment mounts are specified in the applicable equipment specification, the requirements of this Section must be applied to rigid mounts for all rotating or reciprocating equipment that is used to mix, convey, or pressurize fluids (gases and liquids). The requirements of this Section also apply whenever referenced in Specifications for other types of equipment. If conflict exists between this Section and the requirements of individual equipment manufacturers, the more restrictive requirements prevail.

B. Related Sections: The work of the following Sections is related to the work of this Section. Other Sections, not referenced below, may also be related to the proper performance of this work. It is the Contractor's responsibility to perform all the work required by the Contract documents.

1. Section 01 33 10 - Submittals
2. **Section 03 62 00 - Non-Shrink Grouting**
3. Section 40 05 01 - General Requirements for Equipment

1.02 REFERENCES

A. This Section contains references to the following documents. It is a part of this Section as specified and modified. In case of conflict between the requirements of this Section and those of the listed document, the requirements of this Section prevail.

Reference	Title
ANSI/HI 1.4	Centrifugal Pumps – Installation, Operation and Maintenance
ANSI/HI 2.4	Vertical Pumps – Installation, Operation and Maintenance
API RECOMMENDED PRACTICE 686	Recommended Practices for Machinery Installation and Installation Design
ASTM E329	Inspection and Testing Agencies for Concrete, Steel, and Bituminous Materials as Used in Construction
MIL-PRF-907E	Anti-Seize Thread Compound, High Temperature

Reference	Title
SSPC	Society for Protective Coatings Specifications, Vol. 2
IBC	2015 International Building Code (including City of Seattle amendments)

1.03 SUBMITTALS

- A. Procedures: **Section 01 33 10 - Submittals.**
- B. A copy of this section, with addendum updates included, (referenced sections need not be included for this section) with each paragraph check-marked to indicate specification compliance or marked to indicate requested deviations from specification requirements. Check marks denote full compliance with a paragraph as a whole. If deviations from the specifications are indicated, and therefore requested by the Contractor, underline each deviation and denote by a number in the margin to the right of the identified paragraph, referenced to a detailed written explanation of the reasons for requesting the deviation. The Engineer is the final authority for determining acceptability of requested deviations. The remaining portions of the paragraph not underlined will signify compliance on the part of the Contractor with the specifications. Failure to include a copy of the marked-up sections, along with justification(s) for any requested deviations to the specification requirements, with the submittal is sufficient cause for rejection of the entire submittal with no further consideration. Copies of this section must be numbered and marked (specification number and equipment number) for inclusion (filing) with the associated equipment submittal requirements.
- C. Schedule of rigid equipment mount installations specified in **Article 2.01** of this Section.
- D. Name, employer and certificates or other information documenting compliance with the journeyman qualifications requirements for millwrights who will install rigid equipment mounts, as specified in **Paragraph 3.03.C** of this Section.
- E. Provide certificates or other documentation issued by the epoxy grout manufacturer that demonstrates that the grout manufacturer’s technical representative has been factory-trained on installation of epoxy grout for equipment mounts, as specified in **subparagraph 3.02.B.2** of this Section. Compliance with this section is not required where epoxy grout is not used.
- F. Provide list of Contractor’s equipment installation staff that has completed epoxy grout manufacturer’s grout installation training. Compliance with this section is not required where epoxy grout is not used.
- G. Shop Drawings for all equipment pads, equipment anchors, and baseplate or mounting block details. Shop Drawings must depict size and location of equipment pads and reinforcement; equipment drains; equipment anchor, size, location, and projection; expansion joint locations; elevation of top of grout and grout thickness; elevation of top of baseplate; or mounting block; size and location of electrical conduits; and any other equipment mounting features embedded in equipment pads. Shop Drawings for equipment pads, equipment anchors, and baseplate or mounting blocks must be numbered and marked (specification number and equipment number) for inclusion (filing) with the associated equipment submittal requirements.

- H. Equipment anchor calculations.
- I. Results of grout strength tests.

1.04 QUALITY CONTROL

- A. Equipment mount related materials must be sampled and tested by the Owner's materials laboratory.

1.05 DEFINITIONS

- A. Specific equipment mounting terminology used in this Section conforms to the following definitions:
 1. Baseplate: Fabricated (welded structural steel elements), cast, or plate steel base providing a common mounting element on which the legs, feet, or mounting surfaces of equipment are mounted by means of bolted connections.
 2. Soleplate: A machined plate, spanning an opening in the floor or equipment pad, providing a common mounting element on which the legs, feet, or mounting surfaces of equipment are mounted by means of bolted connections.
 3. Mounting Blocks: Multiple smaller baseplates on which individual legs, feet or equipment supports are mounted when equipment or drivers are not fastened to a common baseplate or sole plate.
 4. Equipment Pad: Concrete foundation (block or slab) supporting and elevating equipment mounts above the supporting structural floor slab or local grade.
 5. Mounting Pads: Thickened or raised areas of baseplates and soleplates where the feet or mounting surfaces of mounted equipment and drivers are bolted and/or doweled to the baseplate or soleplate.
 6. Leveling Blocks: Temporary steel blocks placed under baseplates, soleplates, or a mounting block at leveling positions (at equipment anchors) for the purpose of leveling baseplates, soleplates, or mounting blocks prior to grouting.
 7. Shims: Thin stainless steel plates of a uniform thickness installed on top of Leveling Blocks for fine adjustment of level.
 8. Wedges: Pairs of uniformly tapered metal blocks that are stacked with the tapered surfaces reversed (relative to the other wedge) so that the top and bottom surfaces of the wedges are parallel. Wedges are used between equipment pads and baseplates, soleplates, or mounting blocks for the purpose of leveling baseplates, soleplates, or mounting blocks.
 9. Mounting Stud: Threaded rod or bolts anchored to baseplates, soleplates, or mounting blocks for the purpose of mounting equipment or ancillary devices onto baseplates, soleplates, or mounting blocks.

10. Reinforcement Dowels: Steel reinforcement rods embedded in concrete, across a cold joint, for the purpose of transferring loads or force across the joint.
11. Machine Alignment Dowels: Tapered diameter rods inserted in tapered diameter holes for the purpose of aligning machinery. The practice of drilling tapered diameter holes through machinery and baseplates so that Machine Alignment Dowels may be inserted to facilitate alignment of machinery is known as Doweling.
12. Leveling Position: A location on the top of a concrete equipment pad where leveling tools and equipment will be temporarily installed or used for the purpose of leveling baseplates, soleplates, and mounting blocks prior to grouting.
13. Grout Manufacturer: Refers to the manufacturer of the epoxy grout system used for installation of rigid equipment mounts.
14. Grout Manufacturer's Technical Representative(s): Refers to the technical representative(s) of the Grout Manufacturer.

1.06 EQUIPMENT MOUNTING REQUIREMENTS:

- A. Equipment pads, baseplates, and equipment mounting must be of the type, size, and configuration shown on the Drawings. The Contractor may not deviate from the mounting shown without explicit written direction from the Engineer.

PART 2 - PRODUCTS

2.01 GENERAL

- A. Prior to initiating any installation efforts, the Contractor must produce a rigid equipment mount installation schedule containing the expected dates for installing equipment anchors and preparation of equipment pads for leveling, grouting, and final equipment anchor clamping for each item of equipment. The schedule must list the equipment, by equipment tag number, and must list applicable equipment section, motor horsepower, and name of the Contractor's representative responsible for quality control during installation of rigid equipment mounts. The schedule must be accompanied by written verification of equipment anchor clamping torque from the manufacturer of each item of equipment to be installed with rigid equipment mounts.

2.02 CONCRETE EQUIPMENT PADS

- A. Concrete equipment pads must be as shown in the structural details for equipment pads and equipment anchors for rigid mounted equipment.

2.03 BASEPLATES AND MOUNTING BLOCKS

- A. General:
 1. Baseplates for equipment must be as specified in the Drawings.

2. Mounting holes for equipment anchors must be drilled through baseplates and mounting blocks. Mounting holes for equipment anchors must not be burned out and they must not be open slots. An anti-seize or anti-galling compound, as specified in **Article 2.06** of this Section, must be applied to all anchor bolt threads prior to installing nuts on anchor bolts. Terminations requiring connections to baseplates or mounting blocks must be acorn nuts welded to the under side of the baseplate or nuts welded to the underside of the baseplate and plugged with cork, plastic plugs or grease. In no case may the fastener terminate only into the metal base. Where baseplates or mounting blocks are leveled using jackscrews, jackscrew threads must be tapped in thickened pads or otherwise in sufficient metal to provide ease in adjusting level.
3. Mounting pads for equipment must be machined after all welding and stress relieving and must be coplanar within 0.002 inch per foot in all directions. Mounting pads must extend not less than 0.5 inch beyond the perimeter of the foot or mounting surface of the mounted equipment, in any direction.

2.04 GROUT FOR EQUIPMENT PADS

- A. Cementitious Nonshrink Grout: Cementitious Nonshrink Grout, specified in **Section 03 62 00 - Non-Shrink Grouting**, may be used for setting bearing surfaces of baseplates or mounting blocks on equipment pads where equipment drivers are 50 horsepower and smaller and the combined weight of equipment and driver is less than 1000 pounds. Where the term nonshrink grout or cementitious grout is used in the context of details and specifications for equipment mounting it must mean Cementitious Nonshrink Grout. Training and quality control by the grout manufacturer's technical representative are not required for rigid equipment mounts installed with cementitious non-shrink grout.

2.05 EPOXY PRIMER

- A. Epoxy primer must be a lead free, chrome free, rust inhibitive, two-component epoxy primer specifically designed for use on metal substrates and in conjunction with epoxy grout. The epoxy primer must be a product of the epoxy grout manufacturer.

2.06 ANTI-SEIZE/ANTI-GALLING COMPOUND

- A. Anti-seize or anti-galling compound must be a molybdenum disulfide and graphite combination in an aluminum complex base grease conforming to MIL-PRF-907E. Acceptable products include Jet Lube 550 by Jet Lube, Inc., E-Z Break by LA-CO, or equal.

PART 3 - EXECUTION

3.01 GENERAL

- A. Grouting for installation of equipment on equipment pads must take place prior to connecting any field piping or electrical and instrumentation systems. Unless the Engineer accepts an alternate installation procedure in writing, baseplates and mounting blocks must be leveled and grouted with the equipment removed. Pumps must be installed in accordance with this Section and ANSI/HI 1.4 or ANSI/HI 2.4, as appropriate for the type of pumping equipment installed.
- B. Connecting piping with flexible connections and/or expansion joints must be anchored such that the intended uses of these joints are maintained in the piping system without imposing strain on the equipment connections.
- C. Where an equipment manufacturer's installation requirements include a rigid connection between the machine and connecting piping systems, the Contractor must delete any flexible coupling (including equipment connection fittings) shown on the Drawings and install the equipment in the following manner, in lieu of installing the flexible coupling:
 - 1. The equipment pad must be prepared as shown on the details for rigid equipment mounts.
 - 2. The baseplate or mounting blocks supporting the equipment must be installed, leveled, and grouted in place as specified in this Section.
 - 3. Install equipment, aligned and doweled in place.
 - 4. The piping must be installed and aligned to the equipment connections and the field piping connections without welding one of the joints for one section of pipe between the equipment connection and the field piping and all valving. All flanged joints must be bolted up and pressure tested.
 - 5. All piping must be fully supported by supports designed to accept their full weight and thrust forces.
 - 6. Align the final sections of piping with the equipment and field connections without the use of jacks, chain falls or other devices to force it into alignment.
 - 7. The final piping joints must be welded only after the previous steps have been completed and accepted by the Engineer.

3.02 INSTALLATION

- A. Concrete Equipment Pad Preparation:
 - 1. Existing concrete surfaces used as equipment pads must be roughened by chipping the surface. Chipping must remove all laitance and defective or weak concrete and result in a rough surface profile with a 0.25 inch minimum amplitude. Chipping must expose broken aggregate without dislodging unbroken aggregate from the cement matrix and must not cause fractures below the concrete surface. Leveling surfaces of the concrete that have been finished smooth and level for baseplate or mounting block leveling at equipment anchors must be protected from damage during chipping. A light duty, handheld pneumatic chipper with a chisel type tool must be used for chipping the equipment pad concrete surface. Abrasive blast, bush-hammer, jack hammers with sharp chisels, heavy chipping tools, or needle gun preparation of concrete surfaces to be grouted is not acceptable.

2. Prior to leveling activities, satisfactory removal of defective or weak concrete must be demonstrated in the presence of the Engineer by operating the chipper on the chipped concrete surface at locations identified by the Engineer. The chipped surface of the concrete must be such that the final baseplate or mounting block elevation results in the grout manufacturer's recommended grout thickness between the surface of the equipment pad and the lower baseplate flange or underside of mounting block.
 3. All dust, dirt, chips, oil, water, and any other contaminants must be removed and the surface protected with plastic sheeting until grout is installed.
 4. Concrete equipment pad surfaces that have been finished smooth and level for use as leveling positions must be protected from damage during chipping activities. Alternatively, leveling positions may be restored on chipped surfaces. Leveling positions must be restored by installing leveling blocks or leveling plates for jackscrews on a high compressive strength epoxy putty (Philadelphia Resins, Phillybond Blue 6A, or equal). Leveling blocks and leveling plates must be installed level on the epoxy putty.
- B. Baseplates And Mounting Blocks: All surfaces of baseplates and mounting blocks to be in contact with epoxy grout must be cleaned to SSPC SP-6 and must be primed with epoxy primer within 8 hours of cleaning.
- C. Leveling:
1. All machinery must be mounted and leveled by journeyman millwrights. Precision surveying equipment must be used for leveling. Machinists' spirit levels will not be permitted for leveling purposes for any baseplate or mounting block with a plan dimension greater than 4 feet. Baseplates and mounting blocks must be leveled to a maximum tolerance of 0.002 inch per foot or as otherwise required by the equipment manufacturer, if more stringent. An anti-seize or anti-galling compound specified in paragraph 2.06 of this section must be applied to all equipment anchor threads prior to beginning baseplate or mounting block leveling.
 2. All baseplates and mounting blocks must be leveled against steel surfaces (jackscrew plates, leveling blocks, leveling nuts, support plates, or other steel surfaces). Use of other materials for leveling purposes is strictly and specifically prohibited. Unless otherwise specified, baseplates and mounting blocks must be leveled as indicated in the leveling details. Leveling equipment and tools must be stainless steel leveling blocks and shims, steel wedges, or jackscrews bearing on leveling plates. Leveling nuts may be used for leveling baseplates weighing less than 200 pounds. The use of leveling nuts for leveling mounting blocks is not permitted.
 3. After baseplates or mounting blocks have been leveled on the leveling equipment, the Contractor must clamp the baseplates or mounting blocks in position by installing the equipment anchor nuts and washers. Clamping torque must be less than the final clamping torque specified in **Article 2.01** of this Section, but sufficient to hold the baseplate or mounting block in position. The Contractor must verify that the correct level and position of the baseplate or mounting block has been maintained after clamping on the leveling equipment.

4. Leveling blocks must be stainless steel, four inches square and 1-1/2 inches thick with an open-ended slot terminating in the center for the equipment anchor. Leveling blocks must be machined flat on all horizontal surfaces and placed under the baseplate at each equipment anchor. Shims must be pre-cut stainless steel, slotted for removal after grouting, and must extend not less than three inches beyond the baseplate or mounting block. Leveling blocks and shims must be coated with a light oil just prior to beginning the leveling and grouting work. Shims must be placed so the tabs on the shims are easily accessible.
- D. Grouting:
1. Grout forms must be built of minimum 0.75-inch thick waterproof plywood and must be securely braced (minimum brace size must be 2-by-4 lumber). Forms must be designed for a minimum of 6 inches hydrostatic head above the final elevation of the grout, to assist in flow during installation. Equipment mounting grout must be furnished with expansion joints installed at 4- to 6-foot intervals, perpendicular to the centerline of baseplates.
 2. Forms must be coated with 3 coats of paste wax on all areas that will come in contact with the grout to prevent the grout from bonding to the forms. Forms must be waxed before assembly to prevent accidental application of wax to surfaces where the grout is to bond. Before any forms are installed, all concrete surfaces that will contact epoxy grout must be free from any foreign material, such as oil, sand, water, wax, grease, etc. Forms must be liquid-tight. Any open spaces or cracks in forms, or at the joint between forms and the foundation, must be sealed off, using sealant, putty, or caulking compound. All outside vertical and horizontal edges of the grout must have 45-degree chamfers as indicated in the equipment anchor details for rigid equipment mounts. Match chamfers in concrete portions of the equipment pad. Block outs must be provided at all shimming and leveling positions to allow removal of leveling equipment and tools after the grout has cured. Jackscrews must be coated with a light oil or other acceptable bond-breaking compound prior to grouting.
 3. Non-Shrink Grout must be mixed as specified in **Section 03 62 00 – Non-Shrink Grouting**. The grout must be placed and consolidated such that it is free of voids. Grout must be placed at the center of one end of the baseplate and worked toward the ends in such a manner as to force the air out from beneath the baseplate and out the vent holes, to eliminate voids. Grout must be placed in a manner that avoids air entrapment, using a head box to pour grout into the grout holes. When the head box is moved to the next grout hole, a 6-inch high standpipe must be placed over the grout hole and filled with grout.

4. The Contractor must exercise care to never allow the grout to fall below the baseplate level once the grout has made contact with the baseplate. Grout placement must be continuous until all portions of the space beneath the baseplate or mounting block have been filled. Subsequent batches of grout must be prepared so as to be ready when the preceding batch has been placed. Under no circumstances may the grouting operation be halted because of lack of grout mix. After the entire baseplate is full, 6-inch high standpipes must be maintained over each grout hole, to continue purging of air. When the grout has started to take an initial set (typically this is determined by a noticeable increase in temperature and no flow of grout at the vent holes) the standpipes must be removed and excess grout cleaned from all surfaces.
 5. Where the cavity under a baseplate or mounting block extends above the elevation of the top of the bolting flange for the baseplate or mounting block, grouting may be completed in two pours. Under these circumstances, the first grout pour must be continuous until the lower face of the bolting flange for the baseplate or mounting block is submerged in grout a minimum of one inch. The second grout pour must be completed with standpipes and air purges as specified in the previous paragraph.
 6. Grout forms must be checked for leaks throughout grout pours. Leaks must be repaired immediately to prevent formation of voids. A final check of baseplate or mounting block level and elevation must be performed before the grout sets.
 7. A grout sample must be taken for each equipment pad that has a baseplate or mounting block set in grout. Samples will be taken and tested by the Owner's materials laboratory for conformance with the performance characteristics specified in **Section 03 62 00 – Non-Shrink Grouting**. The results must be reported directly to the Engineer. Forms must be removed only after the grout has cured sufficiently and upon specific permission from the Engineer.
- E. Completion:
1. Upon acceptance by the Engineer and the equipment manufacturer's representative and after the grout has reached sufficient strength, grout forms and block outs at leveling positions must be removed. Leveling blocks and shims or wedges and support plates must be removed, leveling nuts and jack screws must be backed off to allow the grout to fully support the baseplate or mounting block. Take care not to damage the grout during removal of extended shimming material or leveling equipment and tools.
 2. The equipment anchor nuts must be tightened, using calibrated indicating torque wrenches, to develop the full clamping force required by the equipment manufacturer.
 3. Equipment anchor nuts must be tightened in increments of not more than 25 percent of the final torque value in an alternating pattern to avoid stress concentration on the grout surface. After tightening equipment anchor nuts to final values, apply additional wax, grease, or mastic to all exposed portions of the equipment anchor beneath the baseplate or mounting block.

4. After applying additional wax or mastic to exposed portions of equipment anchors, block outs (pockets) for access to leveling nuts, leveling blocks and shims, or wedges must be filled with the grout material installed under baseplates or mounting blocks and pointed after the equipment anchor nuts have been tightened to final values. Jackscrews must be removed and holes in the baseplate or mounting blocks filled with a flexible sealant (silicone rubber) or a short cap screw.
5. Check for baseplate or mounting block movement (soft foot) by individually loosening and re-tightening each equipment anchor. Vertical movement at each equipment anchor must be measured and recorded during loosening and retightening and must not exceed 20 micrometers (0.001 inch). Vertical movement must be measured using a magnetic-based dial indicator on the baseplate or mounting block referenced to the grout surface of the equipment pad or other approved method. Soft foot conditions are sufficient cause for removal and reinstallation of grout and baseplates or mounting blocks.
6. Check for grout voids by tapping along the upper surfaces of the baseplate or mounting block. Grout voids are sufficient cause for removal and reinstallation of grout and baseplates or mounting blocks. Grout voids must be marked. Repair of grout voids may be permitted as directed by the Engineer, at the Engineer's sole discretion.

3.03 FINAL INSPECTION

- A. The Engineer will conduct a final inspection with the Contractor for conformance to requirements of the Contract documents.

End of Section 40 05 02

SPECIFICATION SECTION 40 05 08

SS SLIDE GATES

PART 1 - GENERAL

6.02 1.01 DESCRIPTION

- A. Scope: This Section specifies provision and installation of slide gates of stainless steel construction for **flow isolation**.
- B. Type: Slide gates must be of fabricated stainless steel construction with gates, guides, and operators provided by one manufacturer. Gates must meet all requirements of AWWA C561 as applicable, unless otherwise specified.
- C. Related Sections: The work of the following Sections is related to the work of this Section. Other Sections, not referenced below, may also be related to the proper performance of this work. It is the Contractor's responsibility to perform all the work required by the Contract documents.
 - 1. 1. Section 01 33 10 - Submittals
 - 2. 2. Section 40 05 01 - General Requirements for Equipment
 - 3. 3. Section 40 23 00 – Process Pipe, Fittings, and Accessories

6.03 1.02 REFERENCES

- A. This Section contains references to the following documents. They are a part of this Section as specified and modified. Where a referenced document contains references to other standards, those documents are included as references under this Section as if referenced directly. In the event of conflict between the requirements of this Section and those of the listed documents, the requirements of this Section will prevail.

Reference	Title
ASTM A240	Heat-Resisting Chromium-Nickel Stainless Steel Plate, Sheet and Strip for Pressure Vessels
ASTM A269	Seamless and Welded Austenitic Stainless Steel Tubing for General Service
ASTM A276	Stainless Steel Bars and Shapes
ASTM D2000	Rubber Products in Automotive Applications
ASTM D4020	Ultra-High-Molecular-Weight Polyethylene Molding and Extrusion Materials
ASTM F593	Stainless Steel Bolts, Hex Cap Screws, and Studs
ASTM F594	Stainless Steel Nuts
AWWA C513	Open-Channel, Fabricated Metal Slide Gates
AWWA C561	Fabricated Stainless Steel Slide Gates

6.04

6.05 1.03 SUBMITTALS

- A. Procedures: **Section 01 33 10 - Submittals.**
- B. A copy of this specification section, with addendum updates included, and all referenced and applicable sections, with addendum updates included, with each paragraph check-marked to indicate specification compliance or marked to indicate requested deviations from specification requirements. Check marks (✓) denote full compliance with a paragraph as a whole. If deviations from the specifications are indicated, and therefore requested by the Contractor, each deviation must be underlined and denoted by a number in the margin to the right of the identified paragraph, referenced to a detailed written explanation of the reasons for requesting the deviation. The Engineer is the final authority for determining acceptability of requested deviations. The remaining portions of the paragraph not underlined will signify compliance on the part of the Contractor with the specifications. Failure to include a copy of the marked-up specification sections, along with justification(s) for any requested deviations to the specification requirements, with the submittal is sufficient cause for rejection of the entire submittal with no further consideration. Technical acceptance of a requested deviation does not constitute an approval of added costs.
- C. Certificate of Unit Responsibility attesting that the Contractor has assigned, and that the manufacturer accepts, unit responsibility in accordance with the requirements of this section and **Paragraph 1.04.B of Section 40 05 01 - General Requirements for Equipment.** No other submittal material will be reviewed until the certificate has been received and found to be in conformance with these requirements. Unit responsibility for this Section applies to the slide gate and manual operating stem and associated components.
- D. Manufacturer's Shop Drawings, showing materials, dimensions, plan, cross section, and details showing proposed mounting for each size and typical application of gate. Shop Drawings must also show operating stems, wall brackets, and any other accessories associated with the gate. The Contractor must field verify all mounting conditions, dimensions, and elevations of existing structures prior to submitting shop drawings and beginning fabrication.
- E. Structural calculations for gate frame, slide, operating yoke, stem, lift system, and other key elements.
- A. **F. Product Data:**
 - 1. 1. Product information, charts, or graphs to verify that the product provided meets the requirements set forth in this Section.
 - 2. 2. Affidavits of compliance in accordance with AWWA C561, Section 6.3.
 - 3. 3. Applicable operation and maintenance information as specified in **Section 00 72 00 - General Conditions.**
 - 4. 4. Manufacturer's equipment warranty information.
 - 5. 5. Submit operating stems and wall brackets in the same submittal as the associated gates.

6.06 1.04 DESIGN REQUIREMENTS

- A. Design Conditions: Slide gates must be designed for continuous exposure to combined sewage. The gates will be installed in below grade structures.

A. B. Operating Requirements:

Location	Gate Size, inch ^a	Gate type ^b	Opening ^c direction	Bottom ^d seating	Frame ^e type	Design Head	Operator type ^f	Tag ID
						Unseating, FT		

Table Abbreviations:

- ^aWidth by height, as minimum clear opening.
- ^bW = wall mounted; E = Embed mounted; F=Flange Mount.
- ^cU = upward; D = downward; U/NRS=upward, non-rising stem.
- ^dFB = flush bottom; J = J-seal all around opening; S = Standard.
- ^eC = conventional; SC = self contained (yoke-type).
- ^fI = geared crank type; II = handwheel type; III = extension stem with 2" operating nut.

Table Notes:

1. The Contractor must coordinate slide gate and gate appurtenance (extension stem, etc) mounting details with the existing pump station structure and the proposed valve boxes accessing the operating nut above the slide gate.
2. Where wall mount gates are specified, gates must mount to the existing pump station concrete structure (not inflow pipe flange). Modification of existing conditions to accommodate this mounting type are the responsibility of the Contractor. The Contractor must field verify the mounting condition prior to submittal and fabrication of the gates.
3. Where flange mount gates are specified, the Contractor must field verify the existing flange class, thickness, diameter, and bolt pattern prior to preparing shop drawing submittals. Notify the Engineer immediately if the existing flange condition is not suitable for installation of new slide gates.
4. Gate opening dimensions specified are minimum clear openings. Actual opening must not be less than the dimensions shown.

C. Component Sizing:

1. 1. Operating forces used for determining the strength of gate components comprising of yokes, frames, discs, stems, disc nut pockets, and other load-bearing members must be based on the sum of the guide friction force (computed using an opening breakway friction factor as recommended by AWWA C561, or as otherwise recommended by the manufacturer) and the weight of disc and stem.
2. 2. When the gate is in motion, the operating forces must be based on the sum of the frictional force (using a guide friction factor as recommended by AWWA C561, or as otherwise recommended by the manufacturer) and the weight of disc and stem.

PART 2 - PRODUCTS

6.07 2.01 ACCEPTABLE PRODUCTS

- A. Stainless steel slide gates must be Golden Harvest, Waterman, or approved equal, modified to meet specified requirements.

6.08 2.02 EQUIPMENT

- A. Slide Gates:

1. 1. Slide gates must meet the requirements of AWWA C561 except as otherwise specified. Slide gates must be of the heavy-duty type. Frames must be flat back.
2. 2. Stem must be a non-rising type with a heavy-duty stem sized to the calculated lifting forces and required safety factors.
3. 3. Stem guides must be provided in accordance with AWWA C561, Sections 4.4.11 and 4.4.12

- B. Slide Gate Materials:

Component	Material
Gate, guides, and frame	ASTM A240 Type 304 or 304L stainless steel
Stem, stem couplings, and stem guide	ASTM A276 Type 304 stainless steel
Seat and stem guide bushings	ASTM D4020 UHMW Polyethylene
Seal	ASTM D2000 Neoprene Rubber
Fasteners and adjusting hardware	ASTM F593/F594, Type 304 stainless steel
Yoke	ASTM A269 Type 304 stainless steel

- C. Concrete Anchor Bolts: As specified in **Section 05 50 10 - Anchor Bolts and Anchors**, sized per gate manufacturer's recommendations.

6.09 2.03 EQUIPMENT FEATURES

- A. General: Design stresses must not exceed the lesser of 40 percent of the yield strength or 25 percent of the ultimate strength of the materials at maximum load conditions. Minimum thickness of slide, its reinforcing members, and all structural components of the guide and frame must be 0.25 inches.

- B. Frame And Guides:

1. 1. The gate frame must be a rigid, welded unit, composed of the guide rails, cross bars, and dead rails, with a clear opening the same size as the waterway, unless otherwise specified. Mounting configuration will be as specified in **Article**

- 1.04** of this Section. The guides must be of sufficient length to support two-thirds (2/3) the height of the slide, when the gate is fully open. On wall mounted gates, compressible gaskets or grout must be provided between frame and wall as needed to ensure full mating of surfaces and no leakage.
2. 2. On self-contained gates, where the guides extend above the operating floor, they must be sufficiently strong so that no further reinforcing will be required. The yoke to support the operating device must be formed by members welded or bolted at the top of the guides. The arrangement of the yoke must be such that the slide and stem can be removed without disconnecting the yoke. When the slide is too long to allow this, the yoke must be bolted for easy removal.
 3. 3. The yoke must be sufficiently strong to support the lift forces when subjected to a load of 100 pounds pull on the operator. The yoke must be designed so that its deflection under full operating load will not exceed 1/360 of the gate width or ¼ -inch under maximum load, whichever is less.
 4. 4. Gate position indication must be provided as noted below:
 - a. a. All gates must be provided with a tag as specified in **Section 40 07 00 – Mechanical Identification** printed with the gate equipment number and indication of number of turns to reach full open/full closed position. Plate must be installed where it can be seen by workers when manually opening gate.
- C. Slide: The slide must be plate reinforced with structural shapes welded to the plate. The slide must not deflect more than 1/1000 of the span of the gate, or 1/16 inch whichever is greater, under maximum design head. The stem connection must be either the Clevis type, with structural members welded to the slide and a bolt to act as pivot pin, or a threaded and bolted (or keyed) thrust nut supported in welded nut pocket. The pocket and yoke of the gate must withstand at least 2.5 times the rated thrust output of the operator at 40 pounds pull.
- D. Sealing System:
5. 1. Flush bottom seal must be of compressible neoprene must be located on the slide. With the slide open, the invert of the gate must be flush with the channel or opening, with no pockets or cavities for the accumulation of solids. Unless otherwise noted, gates specified in this section will not be used for throttling (partially open) service.
 6. 2. Top and side seals must be able to be replaced without removing the gate frame from the wall thimble.
 7. 3. Gates must use a sealing system of neoprene to achieve the leakage rates specified and to provide a durable sealing system as follows:
 - a. a. Upward Opening Gates: The seating face of the frame must be oriented at an angle to the plane of the mounting flange to affect a wedging action upon closure. Seals must be neoprene or EDPM and be fully adjustable. Invert seal must be mounted on the slide. Side and top seals must be frame mounted.
 - b. b. Downward Opening Gates: Seals must be neoprene or EDPM of the “P” design and be fully adjustable.

E. Stem and Stem Splices

8.

1. Stems shall be manufactured from stainless steel sized to withstand the axial compressive and tensile forces created during gate operation under the specified unbalanced heads and to transmit in compression at least two times the rated output of the lift with a 100-lb effort on the crank or handwheel. Threading on stems shall be single-lead threads of the Acme type. Stem couplings shall have internal threads for transmitting the full thrust of the stem and shall be held in place on the stem with a key, simultaneously engaging the coupling and both stems.

9.

10. F. Stem Extension Guides

11.

1. Stem guides shall be fully adjustable, heavy duty castings. Guide materials will be as specified in **Article 2.02** of this Section. The stem guides must be properly spaced to support the stem as a long column, with maximum spacing not to exceed an unsupported stem slenderness ratio (L/r) of 200 or 6 feet, whichever is less.

12.

13. G. Stem Extensions

14.

1. Stem extensions must be fabricated of stainless steel and capped with an AWWA standard 2-inch square operating nut. Stems must be heavy duty, of sufficient cross-section to transmit a torque of 150 ft-lbsf with a maximum angular deflection of 11.25 degrees over the length of the shaft.

15.

16. H. Lifts

17.

18. 1. Lifting assemblies must be per AWWA C561. Where gates and lifts are to be installed below the local overflow level or are otherwise prone to submergence, utilize UHMW thrust washers in lieu of bearings for the lift assembly.

19.

20. 2.04 COATING SYSTEM

21. A. All cast or ductile iron components must be coated per **Section 09 90 00 – Painting and Coating**. No additional coatings are required for stainless steel components.

PART 3 - EXECUTION

6.10 3.01 INSTALLATION

- A. Unless otherwise specified, slide gates and appurtenances must be installed in accordance with manufacturer's instructions and approved shop drawings.

6.11 3.02 TESTING AND ADJUSTMENT

- A. Shop seat clearance and operating tests and field operating and leakage tests must be performed as per Section 5.2 of the AWWA C561.
- B. Final field adjustment of all clearances, tolerances, stops, seals, etc must be performed by an authorized representative of the gate manufacturer. Stops must be adjusted per the manufacturer's recommendations.
- C. For purpose of this specification, field leakage tests must be performed as specified in AWWA C513/C561 as applicable. Field leakage tests must be conducted with no head on one side of the gate being tested. Prior to testing and commissioning a test plan procedure must be submitted and approved.
- D. The maximum leakage rate for upward opening gates must be 0.02 gallons per minute per foot of seating perimeter for the seating and unseating heads specified.
- E. The maximum leakage rate for downward opening gates must be 0.10 gallons per minute per foot of seating perimeter for the seating and unseating heads specified.
- F. Operating stems and extensions must be installed in true alignment.
- F. Operate gate in the presence of the Engineer and adjust as needed to resolve any noted deficiencies such as leaks, sticky or rough actuation, etc. After all adjustments are made, gates must be operated through a minimum of 2 full cycles in the presence of the Engineer with no deficiencies noted.

End of Section 40 05 08

SPECIFICATION SECTION 40 05 15
PIPE SUPPORTS AND SEISMIC RESTRAINTS

PART 1 - GENERAL

1.01 DESCRIPTION

- A. Scope of Work: This Section specifies supports and seismic restraints for bracing of all piping systems specified in **Section 40 23 00 - Process Pipe, Fittings, and Accessories**.
- B. Related Sections: The work of the following Sections is related to the work of this Section. Other Sections, not referenced below, may also be related to the proper performance of this work. It is the Contractor's responsibility to perform all the work required by the Contract documents.
1. Section 01 33 10 - Submittals
 2. Section 03 30 00 - Cast-in-Place Concrete
 3. Section 40 23 00 - Process Pipe, Fittings, and Accessories

1.02 REFERENCES

- A. This Section contains references to the following documents. They are a part of this Section as specified and modified. Where a referenced document contains references to other standards, those documents are included as references under this Section as if referenced directly. In the event of conflict between the requirements of this Section and those of the listed documents, the requirements of this Section will prevail.

Reference	Title
AISC Manual of Steel Construction	American Institute of Steel Construction, Manual of Steel Construction, Allowable Stress Design - 9th Ed.
FEDSPEC WW-H-171e	Hangers and Supports, Pipe
MFMA-3	Metal Framing Standards Publication
MFMA-102	Guidelines for the Use of Metal Framing
MSS SP-58	Pipe Hangers and Supports - Materials, Design and Manufacture
MSS SP-69	Pipe Hangers and Supports - Selection and Application
MSS SP-89	Pipe Hangers and Supports – Fabrication and Installation Practices
SMACNA, PPIC	Guidelines for Seismic Restraints of Mechanical Systems and Plumbing Piping Systems

1.03 SUBMITTALS

- A. Procedures: **Section 01 33 10 - Submittals**.

- B. A copy of this specification section, with addendum updates included, and all referenced and applicable sections, with addendum updates included, with each paragraph check-marked to indicate specification compliance or marked to indicate requested deviations from specification requirements. Check marks (✓) will denote full compliance with a paragraph as a whole. If deviations from the specifications are indicated, and therefore requested by the Contractor, each deviation will be underlined and denoted by a number in the margin to the right of the identified paragraph, referenced to a detailed written explanation of the reasons for requesting the deviation. The Engineer is the final authority for determining acceptability of requested deviations. The remaining portions of the paragraph not underlined will signify compliance on the part of the Contractor with the specifications. Failure to include a copy of the marked-up specification sections, along with justification(s) for any requested deviations to the specification requirements, with the submittal is sufficient cause for rejection of the entire submittal with no further consideration.
- C. Shop Drawings for each pipe support and restraint shown on the Drawings.
- D. Shop Drawing showing locations of each pipe support to be installed.
- E. Manufacturer's product information for supports and restraints, where prefabricated supports are used.

1.04 OPERATING CONDITIONS

- A. The pipe supports specified in this Section are provided to resist pipe loads occurring in the downward (gravity) direction, as well as for pressure and thrust loadings (direction varies).
- B. The seismic restraints specified in this Section are provided to resist pipe movements and loads occurring as a result of an earthquake or other seismic event.

1.05 SUPPORT AND RESTRAINT DESIGN

- A. Supports and restraints must be sized to fit the outside diameter of pipe, flange, tubing, or, where specified, the outside diameter of insulation. Where supports bolt directly to flanges, they must be sized to match the receiving flange bolt pattern.
- B. Piping systems must not be braced to dissimilar parts of a building or to dissimilar building systems that may respond in a different mode during an earthquake. Examples: wall and a roof; solid concrete wall and a metal deck with lightweight concrete fill.
- C. Branch lines must not be used to brace main lines.
- D. The supporting systems must provide for and control the free or intended movement of the piping including its movement in relation to that of connected equipment. Seismic bracing must not limit the expansion and contraction of the piping system.
- E. There must be no contact between a pipe and support or restraint components of dissimilar metals. Prevent contact between dissimilar metals when supporting copper tubing by use of copper-plated, rubber, plastic or vinyl coated, or stainless steel support components.
- F. Stock support components must be used wherever practical.

PART 2 - PRODUCTS

2.01 ACCEPTABLE PRODUCTS

- A. Prefabricated standard pipe supports and components must be manufactured by B-Line, Carpenter & Patterson, Kin-Line, Grinnell, Michigan, Pipe Shields Incorporated, Superstrut, Unistrut, Standon by Material Resources Inc, Trumbull, or approved equal. Pipe support components must conform to the requirements of MSS SP-69 and FEDSPEC WW-H-171e. Pipe support materials must conform to the requirements of MSS SP-58. Metal framing system components must conform to the metal framing manufacturers' Association Standard MFMA-2.
- B. Prefabricated standard pipe restraints and components must be manufactured by Carpenter & Patterson, B-Line, Kin-Line, ITT Grinnell, Michigan, Pipe Shields Incorporated, Superstrut, Unistrut, or approved equal. Pipe restraint materials must conform to the requirements of MSS SP-58 and MFMA.

2.02 MATERIALS

- A. Unless otherwise specified, pipe supports, restraints, structural attachments, fittings and accessories must be of steel construction and hot dip galvanized per ASTM A123.
- B. Where stainless steel supports are specified, use grade 304 stainless steel.
- C. Materials for grout pads for pipe and valve supports must be per **Section 03 62 00 – Non-Shrink Grouting**.

PART 3 - EXECUTION

3.01 SUPPORT AND RESTRAINT LOCATIONS

- A. Supports and restraints must be located and installed as shown on the Drawings.

3.02 INSTALLATION

- A. Welded and bolted attachments to the building structural steel must be in accordance with the requirements of the AISC Manual of Steel Construction. Unless otherwise specified, drilling or burning of holes in the building structural steel is not allowed.
- B. Drilled and bolted attachments to building structural concrete must be installed in accordance with **Section 05 50 10 – Anchor Bolts and Anchors** and anchor manufacturer's instructions.
- C. Support and restraint components must not be used for purposes other than for which they were designed. They must not be used for rigging and erection purposes.
- D. Lateral and longitudinal bracing must be installed between 45 degrees above and 45 degrees below horizontal, inclusive, relative to the horizontal centerline of the pipe.

- E. Hanger and support components in contact with plastic pipe must be free of burrs and sharp edges.
- F. For pipes and valves which are too close to the pump station floor to accommodate the specified pipe stand or traditional support, install grout support pads constructed per **Section 03 62 00 – Non-Shrink Grouting**. Place minimum two layers of roofing felt between the supported object and the grout pad. Do not place grout in direct contact with any metallic components or surfaces.

3.03 ADJUSTMENTS

- A. The Contractor must adjust supports to obtain required pipe slope and elevation. Shims made of material that is compatible with the piping and support materials may be used. All proposed shims must be approved by the Engineer prior to installation.

End of Section 40 05 15

SPECIFICATION SECTION 40 07 00

MECHANICAL IDENTIFICATION

PART 1 - GENERAL

1.01 DESCRIPTION

- A. A. Scope: Furnish and install tags and identifying markers for:
1. Generators, and other fuel-burning units.
 1. Pumps, and similar motor-driven units.
 2. Fans, blowers, primary balancing dampers, and mixing boxes.
 3. All other mechanical, electrical, or process equipment shown with tag numbers in the Drawings.
 4. New and existing mechanical or process piping and ventilation ductwork.
 5. Other equipment installed as part of this Contract.
- B. B. Existing piping and valves shown to remain within the pump station structure are included in the scope of work.
- C. C. Other equipment not installed or modified as part of this contract and not listed above is not included in the scope of work.
- D. D. Equipment tag numbers are shown throughout the Drawings next to the respective equipment in the following typical notations:
- E. 520SF01 or [520SF01]
- F. See **Section 40 07 00A** at the end of this Section for the Asset On-Boarding Sheet which includes a Project Equipment List.

1.02 SECTION INCLUDES

- G. A. Equipment nameplates.
- H. B. Equipment markers.
- I. C. Equipment signs.
- J. D. Access panel and door markers.
- K. E. Pipe markers.
- L. F. Duct markers.

- M. G. Stencils.
- N. H. Valve tags.
- O. I. Valve schedules.
- P. J. Warning tags.
- Q. K. Instrument tags.

1.03 SUBMITTALS

- R. A. See **Section 01 33 10 - Submittals**.
- S. B. Product Data: For each type of product indicated.
- T. C. Samples: For color, letter style, and graphic representation required for each identification material and device.
- U. D. Label schedule showing the quantity, type, size, color, configuration, material, and text of all tags or labels to be installed.

1.04 QUALITY ASSURANCE

1.2

- 1.3 A. ASME Compliance: Comply with ASME A13.1, "Scheme for the Identification of Piping Systems," for letter size, length of color field, colors, and viewing angles of identification devices for piping.

1.05 COORDINATION

- A. A. Coordinate installation of identifying devices with completion of covering and painting of surfaces where devices are to be applied.
- B. B. Coordinate installation of identifying devices with location of access panels and doors.

PART 2 - PRODUCTS

2.01 EQUIPMENT NAMEPLATES

- A. Corrosion-resistant metal, with data engraved or stamped, permanently attached on equipment.
 - 1. Data:
 - a. Equipment Tag Number as shown in the Drawings (may be furnished on separate tag from manufacturer data).
 - b. Manufacturer, product name, model number, and serial number.
 - c. Capacity, operating and power characteristics, and essential data.

- d. Labels of tested compliances.
 - e. Distinguish among multiple units, indicate operational requirements, indicate safety and emergency precautions, warn of hazards and improper operations, and identify units.
2. Letter Size: Minimum 1/4 inch (6.4 mm) for name of units if viewing distance is less than 24 inches (600 mm), 1/2 inch (13 mm) for viewing distances up to 72 inches (1830 mm), and proportionately larger lettering for greater viewing distances. Include secondary lettering two-thirds to three-fourths the size of principal lettering.
 3. Location: Accessible and visible.
 4. Fasteners: Screws or Rivets.

2.02 EQUIPMENT SIGNS

- A. Engraved, color-coded laminated plastic.
 1. Terminology: Match schedules.
 2. Data:
 - a. Equipment Tag Number as shown in the Drawings.
 - b. Name and plan number.
 - c. Equipment service.
 3. Size: 2-1/2 by 4 inches (64 by 100 mm) for control devices, dampers, and valves; 4-1/2 by 6 inches (115 by 150 mm) for equipment.
- B. Pump Number Labels
 1. Adhesive labels
 - a. Minimum 4 inches tall.
 - b. Black text on yellow background.
 - c. Data: Pump number (i.e. "1", "2", etc.).

2.03 ACCESS PANEL AND DOOR MARKERS

- A. 1/16-inch (1.6-mm) thick, engraved laminated plastic, with abbreviated terms and numbers corresponding to identification. Provide 1/8-inch (3.2-mm) center hole for attachment.
- B. Fasteners: Self-tapping, stainless-steel screws.

1.4

2.04 PIPING IDENTIFICATION DEVICES

- A. Manufactured Pipe Markers, General: Preprinted, color-coded, with lettering indicating service, and showing direction of flow.
1. Colors: Comply with ASME A13.1, unless otherwise indicated.
 2. Lettering: Use piping system terms indicated and abbreviate only as necessary for each application length.
 3. Pipes with OD, Including Insulation, less than 6 Inches (150 mm): Pretensioned Pipe Markers extending 360 degrees around pipe at each location.
 4. Pipes with OD, Including Insulation, 6 Inches (150 mm) and Larger: Shaped Pipe Markers at least three times letter height and of length required for label.
 5. Arrows: Integral with piping system service lettering to accommodate both directions; or as separate unit on each pipe marker to indicate direction of flow.
- B. Pretensioned Pipe Markers: Precoiled semirigid plastic formed to cover full circumference of pipe and to attach to pipe without adhesive.
- C. Shaped Pipe Markers: Preformed semirigid plastic formed to partially cover circumference of pipe and to attach to pipe with mechanical fasteners that do not penetrate insulation vapor barrier.
- D. Stencils:
1. Stencils: Prepared with letter sizes according to ASME A13.1 for piping; minimum letter height of 1-1/4 inches (32 mm) for ducts.
 2. Stencil Material: Fiberboard.
 3. Stencil Paint: Exterior, gloss, black, unless otherwise indicated. Paint may be in pressurized spray-can form.
 4. Identification Paint: Exterior, in colors according to ASME A13.1, unless otherwise indicated.

2.05 VALVE TAGS

- A. Valve Tags: Stamped or engraved with 1/4-inch (6.4-mm) letters for piping system abbreviation and 1/2-inch (13-mm) numbers. Provide 5/32-inch (4-mm) hole for fastener.
1. Material: 0.0375-inch (1-mm-) thick stainless steel.
 2. Valve-Tag Fasteners: Brass wire-link or brass beaded chain.

2.06 PROCESS AND INSTRUMENTATION DIAGRAMS

- A. Provide a laminated copy of all Process and Instrumentation Diagram sheets for each facility (Drawing sheets with 'D' designation) with all as-built markups incorporated. Sheets must be 11x17 size, laminated. Furnish 2 copies per site. Deliver to the site.

2.07 WARNING TAGS

- A. Warning Tags: Preprinted or partially preprinted, accident-prevention tags; of plasticized card stock with matte finish suitable for writing.
 - 1. Size: 3 by 5-1/4 inches (75 by 133 mm) minimum.
 - 2. Fasteners: Brass grommet and wire.
 - 3. Nomenclature: Large-size primary caption such as DANGER, CAUTION, or DO NOT OPERATE.
 - 4. Color: Yellow background with black lettering.

PART 3 - EXECUTION

3.01 EQUIPMENT IDENTIFICATION

- A. Install and permanently fasten equipment nameplates on each major item of mechanical equipment that does not have nameplate or has nameplate that is damaged or located where not easily visible. Locate nameplates where accessible and visible. Include nameplates for the following general categories of equipment: fans, pumps, and motors.
- B. Install equipment signs with screws on or near each major item of mechanical equipment. Locate signs where accessible and visible.
- C. Install access panel markers with screws on equipment access panels.
- D. Install pump number labels on associated motors. 1 label prominently located on the side of the motor, and 1 label on top of the motor, clearly visible from the upper level.

3.02 PIPING IDENTIFICATION

- A. Install manufactured pipe markers indicating service on each piping or ductwork system. Install with flow indication arrows showing direction of flow.
 - 1. Pipes with OD, Including Insulation, less than 6 inches (150 mm): Pretensioned pipe markers. Size to ensure a tight fit.
 - 2. Pipes with OD, Including Insulation, 6 inches (150 mm) and Larger: Shaped pipe markers. Size to match pipe and secure with fasteners.
- B. Locate pipe markers and color bands where piping is exposed in finished spaces; machine rooms; accessible maintenance spaces such as shafts, tunnels, and plenums; and exterior nonconcealed locations as follows:
 - 1. Near each valve and control device.

2. Near each branch connection, excluding short takeoffs for fixtures and terminal units. Where flow pattern is not obvious, mark each pipe at branch.
3. Near penetrations through walls, floors, ceilings, and nonaccessible enclosures.
4. At access doors, manholes, and similar access points that permit view of concealed piping.
5. Near major equipment items and other points of origination and termination.
6. Spaced at maximum intervals of 25 feet (15 m) along each run. Reduce intervals to 10 feet (7.6 m) in areas of congested piping and equipment. Minimum 1 label per line per each level of the pump station.

3.03 DUCT IDENTIFICATION

- A. Stenciled Duct Marker: Stenciled markers, showing service and direction of flow.
- B. Locate markers near points where ducts enter into concealed spaces and at maximum intervals of 50 feet (15 m) in each space where ducts are exposed or concealed by removable ceiling system.

3.04 VALVE-TAG INSTALLATION

- A. Install tags on valves and control devices in piping systems, valves within factory-fabricated equipment units; plumbing fixture supply stops; shutoff valves; faucets; convenience and lawn-watering hose connections; and HVAC terminal devices and similar roughing-in connections of end-use fixtures and units. List tagged valves in a valve schedule.

3.05 WARNING-TAG INSTALLATION

- A. Write required message on, and attach warning tags to, equipment and other items where required.

3.06 ADJUSTING

- A. Relocate mechanical identification materials and devices that have become visually blocked by other work.

3.07 CLEANING

- A. Clean faces of mechanical identification devices prior to Physical Completion.

End of Section 40 07 00

SPECIFICATION SECTION 40 23 00

PIPE, FITTINGS, AND ACCESSORIES

PART 1 – GENERAL

6.12 SUMMARY

- A. Section Includes:
1. Pipe fittings, joining materials, and appurtenances.
- B. Related Sections: The work of the following Sections is related to the work of this Section. Other Sections, not referenced below, may also be related to the proper performance of this work. It is the Contractor's responsibility to perform all the work required by the Contract documents.
1. Section 01 33 10 - Submittals
 2. Section 40 23 04 - Pipe and Fittings Pressure and Leakage Testing

6.13 PROJECT CONDITIONS

- C. Work under this Section includes all pipe and fittings on the Project, both internal and external to the Pump Station structure.

6.14 SUBMITTALS

- D. Submit manufacturer's specifications, catalog cuts, technical product data, installation instructions, and other data necessary to demonstrate that pipe, fittings, and accessories are in conformance with these specifications.
- E. The Contractor must furnish a certified affidavit of compliance for all pipe and other products or materials furnished under this Section certifying that each material item complies with the specified requirements.
- F. Piping Layout Drawing: Submit dimensioned layout drawing for interior and exterior piping 4" and larger. Drawings must include dimensions, fittings, locations of equipment, valves, and appurtenances, joint locations and details, types and locations of supports. Drawings must be coordinated with all other work as well as existing conditions. Shop fabrication spool drawings must show materials, diameters, pipe wall thickness, linings, coatings, fittings, branches, flanges and other joint preparation details, dimensions, and other appurtenances to be supplied. The Contractor is responsible for field verifying all dimensions.

6.15 QUALITY ASSURANCE

- G. Codes and Standards: Comply with the provisions of the following codes and standards except as otherwise shown or indicated.

1. American Society for Testing and Materials (ASTM).
2. American Water Works Association (AWWA).
3. City of Seattle Standard Specifications for Road, Bridge, and Municipal Construction, 2023 Edition.

In the event of conflict between the codes and standards listed above and the requirements of these specifications, the more restrictive requirement applies.

- H. Class numbers or pressure rating and cover conditions must be clearly marked on the pipe and fittings at the factory. The proposed marking system must be submitted to the Engineer for approval prior to shipment of any pipe to the Project Site.

6.16 STORAGE AND PROTECTION

- A. Pipe delivered to the site must be stored and protected in keeping with construction best practices. At minimum, pipe must be covered and protected from contact with other materials. Extra care must be taken to protect interior and exterior coatings of pipes.
- B. At no time may other pipes or material be placed or stored within other pipes.
- C. Repair of damage to exterior pipe coatings will be at the discretion of the Engineer. Chipped or damaged interior linings are cause for rejection of the pipe.

PART 2 – PRODUCT

7.01 DUCTILE IRON PIPE AND FITTINGS

- A. The following materials must be provided where shown on the Drawings:
1. Ductile Iron Pipe:
 - a. Pipe
 - 1) ANSI/AWWA C150/A21.50.
 - 2) ANSI/AWWA C151/A21.51.
 - b. Fittings
 - 1) ANSI/AWWA C110/A21.10 or
 - 2) ANSI/AWWA C153/A21.53.
 - c. Minimum pressure class for pipe fittings:
 - 1) 12-inch and smaller: 350 psi pressure class.
 - 2) Larger than 12-inch: 250 psi pressure class.

- d. Thickness class for ductile iron pipe:
 - 1) Class 52 minimum for all pipe sizes.
 - 2) Class 53 minimum for all fabricated flanged or grooved spoos.
- e. Interior Lining
 - 1) Buried wastewater force main piping and fittings installed outside the building envelope: Ceramic epoxy lining formulated for wastewater service. Protecto 401 by Induron Coatings, Inc, or approved equal.
 - 2) All other ductile iron piping and fittings: Double thick cement-mortar lining conforming to AWWA C104/A21.4, unless otherwise specified.
- f. Exterior Coatings:
 - 1) Buried Service: Asphaltic coating.
 - 2) Above Ground and Indoor Service: Coated per **Section 09 90 00 – Painting and Coating**.
- g. Polyethylene Encasement:
 - 1) Minimum 8-mil thickness, compliant with AWWA C105
- h. Push-on and Mechanical Joints:
 - 1) ANSI/AWWA C111/A21.11.
- i. Restrained Push-on Joints for buried Force Mains and liquid-conveying pipes:
 - 1) Flex-Ring Pipe, American Ductile Iron Pipe.
 - 2) TR Flex, US Pipe.
 - 3) Or approved equal.
- j. Restrained Push-on Joints for buried ventilation piping:
 - 1) Flex-Ring Pipe, American Ductile Iron Pipe.
 - 2) TR Flex, US Pipe.
 - 3) Or approved equal.
 - 4) Mechanical joint pipe with wedge restraint glands conforming to the remaining requirements of this section may also be used in this application.

- k. Wedge restraint glands for buried piping: Must have same or greater pressure rating as associated piping. Must be compliant with City of Seattle Standard Specification **Section 9-30.2(4)**.
 - l. Flanged Joints: ANSI/AWWA C115/A21.15, Class 125. Where Drawings show new flanged pipe connecting to existing flanged pipe, field-verify the existing flange configuration and furnish new connecting flange with compatible size, class, facing, and bolt pattern.
 - m. Flange Gaskets: Full face, made of nitrile, or other material specifically compounded for wastewater service with petroleum exposure.
 - n. Flange Isolation Gaskets/Bolt Kits: Select Type E or F gaskets as required to match existing flange face type. Isolation washers and bolt sleeves shall be furnished.
 - 1) Advance Products and Systems, Inc.
 - 2) Drake Specialties.
 - 3) GPT Industries.
 - 4) Or approved equal.
 - o. Grooved Couplings. Minimum working pressure of 250 psi. Gaskets must be nitrile or other material specifically compounded for wastewater service with petroleum exposure.
 - 1) Victaulic, flexible style.
 - 2) Grinnell, flexible style.
 - 3) Or approved equal.
2. Restrained Telescoping Double-Ball Joints for buried Force Mains and ventilation piping:
- a. Joints must be able to expand, contract, rotate, and deflect sufficiently to accommodate a vertical displacement of not less than **[INSERT VERTICAL DEFLECTION HERE (note, 12" typical)]** inches.
 - b. Joints must be constructed of ductile iron and coated and lined with fusion-bonded epoxy.
 - c. Joints must be fully mobile when unpressurized.
 - d. Joint ends must be compatible with the Contractor's submitted joint restraint system for ductile iron pipe.
 - e. Minimum working pressure of 125 psi.
 - f. FJ Restraint by Romac, Inc.
 - g. Or approved equal.

3. Restrained Flange Adapters: rated at minimum working pressure of 300 psi (pipe 18" and smaller) or 150 psi (larger than 18 inches)
 - a. Adapters must provide a flange-compatible end when installed on field-cut ductile iron pipe.
 - b. Adapters must be constructed of ductile iron and coated with fusion-bonded epoxy.
 - c. EBAA Iron Megaflange Series 2100.
 - d. Or approved equal.
 4. Restrained Flange Coupling Adapters: rated at minimum working pressure of 250 psi.
 - a. Adapters must provide a flange-compatible end when installed on field-cut ductile iron pipe.
 - b. Adapters must be constructed of ductile iron and coated with fusion-bonded epoxy.
 - c. Romac Restrained Flange Coupling Adapter.
 - d. Or approved equal.
 5. Flange adapter, set screw style: minimum working pressure of 200 psi
 - a. Adapters must provide a flange-compatible end when installed on field-cut ductile iron pipe.
 - b. Adapters must be constructed of ductile iron and coated with fusion-bonded epoxy.
 - c. EBAA Iron E-Z Flange Series 1000.
 - d. Or approved equal
 6. Electrical Isolation Pipe Couplings: AWWA C219 with insulating boot: minimum working pressure of 250 psi.
 - a. Romac IC501.
 - b. Or approved equal.
 7. Service and type requirements for pipe and fittings are generally indicated in the Drawings. Pipe materials for service conditions not listed will be as specified in other Sections, as indicated on the Drawings, or, in the absence of any definite requirement, as determined by the Engineer. Where optional pipe materials or fittings are specified for a particular service, either may be provided at the Contractor's option.
- B. Coatings for ductile iron pipe and fittings will be as specified in **Section 09 90 00 – Painting and Coating**.

7.02 GALVANIZED STEEL PIPE AND FITTINGS

- A. Steel pipe for sump pump force main and designated drains shall be in accordance with ASTM A53 Grade B, Schedule 80.
- B. Steel pipe and fittings shall be hot-dipped galvanized in accordance with ASTM A123.
- C. Fittings shall be threaded.

7.03 PVC PIPE AND FITTINGS

- A. PVC pipe must be Schedule 80, conforming to the requirements of ASTM D 1785. Fittings shall conform to ASTM D 1785. Joints must be push on. Pipe 4-inches and smaller must be solvent welded. Pipe cement must be of a contrasting color that is easily visible. Pipe larger than 4 inches must be rubber gasketed unless noted otherwise.

2.04 JOINT BOLTS, NUTS AND WASHERS

- A. Unless otherwise specified or noted, joint bolts, nuts and washers on buried piping must be low alloy steel cathodic to pipe with a minimum yield strength of 60,000 psi, and all other joint bolts, nuts and washers must be low carbon steel, ASTM A307, Grade B, hot-dip galvanized per ASTM F2329.

2.05 MODULAR WALL SEALS

- A. Modular wall seals for pipe and conduit penetrations must be Link-Seal model S-316 by GPT Industries or approved equal. Sealing elements must be EPDM with stainless steel hardware.

2.06 HYDROPHILIC WATER STOPS

- A. Hydrophilic water stops must be capable of producing a seal between ductile iron pipe and freshly mixed concrete that is watertight to a hydrostatic head of at least thirty feet. The stops must swell in the presence of water and be suitable for service in wastewater environments. The stops must be applied to pipe surfaces using an adhesive when recommended by the water stop manufacturer. Swellstop by Sika or approved equal.

2.07 CAMLOCK COUPLING ADAPTERS

- A. Camlock couplings for quick-connecting temporary piping must consist of a male end cam and groove style coupling with integral flange of the size shown on the drawings. Flanges must be Class 150 per ANSI/ASME B16.1. Couplings must be constructed of stainless steel. Furnish 1 locking dust cap with each coupling adapter. Style 'PFA' by PT Coupling or approved equal.

PART 3 - EXECUTION

3.01 GENERAL

- I. Pipe fabrication and installation may not begin prior to the Engineer's approval of the Piping Layout Drawing. The Engineer may require that installed pipe not in conformance

with the approved layout drawing be removed and reworked at the Contractor's expense.

- J. Adherence to Standards and Instructions: All pipe, of whatever material, must be transported, handled, stored, and installed in keeping with applicable AWWA standards and manufacturer's instructions for the particular pipe material involved.
- K. Responsibility for Materials: During loading, transportation, unloading, and storage every precaution must be taken to prevent injury to pipe, fitting, and accessories and to prevent damage to pipe and fitting linings and coatings. Pipe must be protected during handling against impact shocks and free fall. Pipe must be kept clean at all times, and no pipe may be used in the work that does not conform to the appropriate specifications.
- L. Ductile Iron Pipe: Install in accordance with applicable provisions of AWWA Specification C600, latest edition, and DIPRA installation guide for ductile iron pipe. Bedding must be Class B per Standard Plan 285. Refer to trench section details in the Drawings. Install polyethylene encasement and special beddings where shown in the Drawings.
- M. PVC Pipe: Install in accordance with the Plastic Pipe Association Handbook and the Nibco Chemtrol Plastic Piping Handbook. For underground applications, install in accordance to ASTM Standard D2321. Bedding for all buried PVC pipe must be Class B with Mineral Aggregate Type 22, per Standard Plan 285.
- N. Provide caps or plugs for all open ends of pipe lines and equipment during installation to keep dirt and other foreign matter out of pipe and equipment.

3.02 PREPARATION

- O. Clean gaskets and all surfaces in contact with gaskets; comply with manufacturer's instructions.
- P. Keep interior of pipe and fittings clean.
- Q. Prepare piping connections to equipment with flanges.

3.03 PIPING JOINTS AND CONNECTIONS

R. Mechanical Joints

1. Make up with Style A plain rubber molded gaskets, unless otherwise specified.
2. Wash socket plain end and gasket thoroughly with soapy water before jointing.
3. Deflect joints within the manufacturer's specified allowable range, where shown on the Drawings.

S. Flanged Joints

1. The Contractor is required to place all flanged pipe valves, fittings, etc. in absolutely true and parallel alignment so that faces of all connecting flanges will

be true and fair before bolting same together to guarantee that no strains will be imposed on the flanges, other than those due to hydrostatic pressure.

2. All flanged pipe, valves, fittings, etc. must be securely supported against settlement and misalignment.
 3. Where new pipe joins existing pipe, select new flange class, facing, and bolt pattern to match existing flange class and provide a flange isolation gasket kit, including isolating washers and bolt sleeves.
 4. Minimize use of filler flanges as much as possible.
- T. Screw Thread Joints
1. Make up joints with sectional pipe dope applied to male threads only.
 2. Threads exposed after joints are made up must be mopped with the pipe dope to prevent rust.
- U. PVC Pipe Joints
1. Pipe ends must be clean and free of debris, grease, etc. Apply primer.
 2. Apply PVC cement and fully home the joint before curing.
- V. Grooved Joints
1. Pipe ends must be clean and free from indentations and projections, in the area from pipe end to groove.
 2. The gasket style and elastomeric material (grade) must be verified as suitable for the intended service as specified.
 3. Contractor must refer to latest copy of Victaulic's Field Assembly and Installation Instruction Pocket Handbook (I-100).
- W. Expansion Joints, Dismantling Joints, and Flange Coupling Adapters:
1. Install these joints or adapters as the last/closure components in each run of piping. Pipe, fittings, and equipment on either side of the joint or adapter must have all supports installed prior to joint or adapter installation. Pipe on either side of the joint or adapter must be cut with square ends with a gap not to exceed 50% of the fitting's allowable tolerance. Joints or adapters must be installed per manufacturer's recommendations.
 2. Properly align piping on either side of joints and couplings prior to installing the fitting. Do not use couplings to make up misalignment or offsets.
 3. If applicable, install thrust restraint rods on dismantling joints where shown on the Drawings. Set rods and nuts with the piping system depressurized.

3.04 EXTERIOR PIPE INSTALLATION

- X. General Pipe Laying: Thoroughly clean all pipe, special castings, valves, fittings, and the bells and/or spigots of same of all earth or other foreign matter before fitting together. The spigot end must be adjusted in the bell of the pipe, special casting or valve to allow for uniform gasket space, and the insertion mark must be flush with the mouth of the bell. Properly installed spigots will not contact the back of the bell.
- Y. All pipe and fittings must be transported, offloaded, handled, and assembled in accordance with the manufacturer's requirements, including any special handling requirements for handling of epoxy lined pipe.
- Z. All pipe must be laid in the presence of the Engineer or the Engineer's representative.
- AA. Prior to being lowered into the trench, each joint of pipe must be carefully given a final inspection to see that each is clean, sound, and free of defects. Damaged sections must be repaired to the satisfaction of the Engineer or removed from the Project Site.
- BB. Pipe must be laid accurately to the line and grade as designated on the Drawings. Unless otherwise noted, all pipes are to be installed at a uniform grade, continuous from points of connection to pump station, or other control points.
- CC. The Contractor is to locate and uncover existing pipes along the path of new pipes prior to beginning new pipe installation. The Contractor must verify existing pipe elevations and determine if any clearance problems exist. In the event of any alignment conflicts, the Contractor must notify the Engineer promptly. The Engineer must approve any changes in grade prior to beginning pipe laying.
- DD. Prior to making pipe joints, all surfaces of the portion of the pipe to be jointed or of the factory-made jointing materials must be clean and dry.
- EE. Gaskets, whether for the mechanical joint type or push joint type, must be clean, flexible, and, where lubrication is required, be lubricated with a lubricant recommended by the manufacturer.
- FF. Pipe must be laid in perfect alignment between turns. No abrupt changes, either in grade or alignment, are permitted. At such locations where alignment changes are indicated on the Plans, fittings and adjacent pipe will be restrained by harnesses or special fittings or external blocking.
- GG. Where new pipe is connected to existing pipe, make connection with isolation couplings as shown on the drawings. Isolating washers and bolt sleeves shall be provided for all tie rods and restraint harnesses.
- HH. Where wedge restraint glands or tie rods are used in buried applications, they must be fully encased in wax tape.

3.05 INTERIOR PROCESS PIPE INSTALLATION

- A. Process pipe fabrication and installation may not begin prior to approval of the Piping Layout Drawing by the Engineer (see **Paragraph 1.03.C** of this Section). Locate and

install piping as shown on the Drawings and approved layout drawing. Provide temporary supports for piping during assembly. Process piping must be installed in true horizontal and vertical alignment and verified with a level before final assembly. Joints shall be aligned and assembled per **Article 3.05** of this Section.

- B. The Engineer may require that installed pipe not in conformance with the approved layout drawing be removed and reworked at the Contractor's expense.

3.06 TESTING PIPING SYSTEMS

- II. See **Section 40 23 04 – Piping and Fittings Pressure and Leakage Testing.**

End of Section 40 23 00

SPECIFICATION SECTION 40 23 01

PUMP STATION VALVES

PART 1 – GENERAL

1.01 SUMMARY

- A. This Section specifies material requirements, standards, installation, and testing for valves, and corporation stops (corp stops) inside the Pump Stations (PS). Valves covered in this Section include the following:
1. Double Disc Gate Valves
 2. Resilient Seat Gate Valves
 3. Check Valves
 4. Corporation stops and ball valves
 5. Valve operating extensions and other accessories

1.02 REFERENCES

- A. AWWA C500 – Gate Valves for Water and Sewage Systems.
- B. AWWA C515 – Resilient-Seated Gate Valves for Water and Sewage System.
- C. AWWA C550 – Protective Epoxy Interior Coatings for Valves.
- D. AWWA C598 – Standard for Swing-Check Valves for Waterworks Services.

1.03 SUBMITTALS

- A. Shop Drawings: Submit Shop Drawings for all valves, operators, and any special items including extension stems, extension bonnets, supports, operators, and brackets in accordance with **Section 01 33 10 - Submittals**.
- B. Shop Drawings must include certified assembly drawings of the valves showing principal dimensions, construction, materials used for all parts, location of pilots, critical clearance dimensions for installation, lubrication type and quantity if required, and total assembled weight of the valves.
- C. Manufacturer's specifications, catalog cuts, technical product data, installation instructions, and other data necessary to demonstrate that valves are in conformance with these specifications
- D. Operation and Maintenance Data: Submit operation and maintenance data for all valves and operators supplied in accordance with **Section 00 73 00 – Supplementary Conditions** and **Section 01 33 10 - Submittals**.

1.04 QUALITY ASSURANCE

- A. Codes and Standards: Equipment furnished and installed under this Section must comply with the following codes and standards except as otherwise shown or indicated.
 - 1. American Water Works Association (AWWA): All applicable standards.
 - 2. American Society for Testing and Materials (ASTM).
- B. In the event of conflict between the codes and standards listed above and the requirement of these specifications, the more restrictive requirements apply.
- C. Valve manufacturer's name, valve size, pressure rating, and direction of opening to be marked on valve.
- D. The materials and methods of manufacture, and completed valves and appurtenances are subject to inspection and rejection by the Engineer at any time.

PART 2 – PRODUCTS

2.01 GENERAL

- A. Valves and operators must be of the size and type indicated on the Drawings or specified herein. Where a specific valve type is not indicated, the Contractor must provide valves with the size equal to that of the pipeline in which it is installed, and of the type used for similar services.
- B. Pressure Rating: As specified, either herein or by referenced Standard, unless otherwise indicated in the Drawings.
- C. Valve Ends: See Equipment List on Drawings.
 - 1. Flanged: ANSI B16.1 Class 125.
 - 2. Mechanical: AWWA C111.
 - 3. Threaded: NPT Standard.
 - 4. Grooved: AWWA C606.
 - 5. Socket: Solvent-weld.
- D. Valves to open counterclockwise, unless otherwise specified; verify direction with Engineer.
- E. Valve Actuators:
 - 1. All valves, including those equipped with motorized or cylinder operators for automatic operation, must be equipped with manual actuators. All interior valves with manual actuators must be equipped with handwheels, lever or handle operators, as indicated on the Equipment List and Drawings. Gate and other shutoff valves in external below grade vaults must be equipped with standard 2-inch operating nuts.

2. Unless otherwise required by the Engineer, the direction of rotation of the wheel, wrench nut, or lever to open the valves must be to the left (counter-clockwise). Each valve body or actuator must have cast thereon the word "Open" and an arrow indicating the direction to open.
 3. Chainwheels: Furnish chainwheels for all valves with a height at centerline above the floor of 7 feet or greater, or as shown on the Drawings. Chainwheels must be of aluminum or stainless steel construction and must attach directly to gate valves. Chainwheels which attach to handwheels will not be permitted. Chainwheels must be furnished with a secondary restraint system capable of arresting the fall of chainwheels which come loose or fall off of the valve. Chains must be hot-dip galvanized and weldless. Chainwheels must be by Trumbull Manufacturing, Babbitt, or approved equal.
- F. Valve Operating Stem Extensions and Stem Guides:
1. Where shown on the Drawings, operating stem extensions must be minimum 2-inch diameter galvanized or stainless steel schedule 80 pipe, finished with a standard 2-inch square operating nut. Stem connections must be pinned.
 2. Stem guides must be ductile iron or stainless steel body with bronze bushings. Ductile iron body must be coated with fusion-bonded epoxy. Guides must have an adjustable range of 2.75 to 17.25 inches or greater from the mounting wall and be capable of receiving bushings for 2-inch nominal diameter valve stems.
 3. Adjustable Stem Guide by Trumbull or approved equal.
- G. Valve Coatings:
1. All valves must be furnished with a fusion-bonded, abrasion-resistant epoxy coating suitable for atmospheric service in wastewater environments.

2.02 DOUBLE DISC GATE VALVES

- A. Conform to, as a minimum, AWWA C500. Size, quantities, and ends must be as shown on the Drawings.
- B. Working pressure must be rated at 125 psi, minimum.
- C. Valves must be cast iron body, double-disc gate valves, fully bronze mounted with nonrising stem and parallel seats.
- D. Manufacturers:
 1. Kennedy
 2. Clow
 3. Or approved equal.
- E. Contractor is cautioned that double disc gate valves are typically a long-lead time item.

2.03 RESILIENT SEAT GATE VALVES

- A. Conform to, at a minimum, AWWA C515. Size, quantities, and ends must be as shown on the Drawings.
- B. Working pressure must be rated at 125 psi, minimum.
- C. Valves must be ductile iron body, resilient seat gate valves, fully bronze mounted with non-rising stem.
- D. Manufacturers:
 - 1. Kennedy
 - 2. Clow
 - 3. Or approved equal.

2.04 CHECK VALVES

- A. Iron Body Check Valves
 - 1. Check valves for 2" and larger sewage pump and sump pump discharge or sludge piping must be of the unobstructed waterway, quick closing, swing type with iron body, flanged ends, and bronze trim. Valves must be resilient disc with bronze seat and must be suitable for mounting in vertical lines with the flow upwards. Valves must be furnished with a spring-and-lever closure assist.
 - 2. Valves must conform to AWWA C 508.
 - 3. Hinge pins must be stainless steel with both ends extending through bronze-bushed bearings and outside stuffing boxes with grease lubricated packing or O-ring seals.
 - 4. Flanges must be flat faced with ANSI B16.1, Class 125 diameter and drilling.
 - 5. Where necessary for sump pump discharge lines, furnish threaded companion flanges to connect valves to adjacent piping.
- B. Manufacturers:
 - 1. Kennedy
 - 2. Clow
 - 3. Or approved equal.
- C. Working pressure must be rated at 125 psi, minimum.

2.05 CORPORATION STOPS (CORP STOP)

- A. Corp Stop must be a ball design and open by a quarter turn of valve stem. Size and quantity must be as shown on the Drawings.

- B. Inlet end must have either male Standard AWWA corporation valve inlet threads conforming to AWWA Standard C800-89 or male iron pipe threads as called out on the Drawings.
- C. Outlet must be compatible with female iron pipe threads as called out on the Drawings.
- D. Working pressure must be rated at 125 psi, minimum.
- E. Manufacturers:
 - 1. Red Valve Co.
 - 2. Onyx Valve Company
 - 3. Proco
 - 4. Ford Meter Box
 - 5. Or approved equal.

2.06 VALVE OPERATING BEVEL GEARBOXES

- A. Gearboxes must be furnished with appropriate adapters to mate with the valve they are installed on. The operating end of the gearbox must be furnished with a 2" square operating nut. Gearboxes must change the axis of valve operation by 90 degrees.
- B. Gearboxes must be by Rotork, Trumbull, or approved equal.

2.07 FLOOR BOXES FOR VALVE OPERATORS

- A. Floor boxes for valve operators must be cast-iron and heavy duty, suitable for traffic loading. Boxes must include integral bronze bushings sized to the associated valve stem and be of sufficient size to contain a standard 2" square operating nut with valve wrench attached.
- B. Floor boxes must be by Trumbull Mfg. Co or approved equal.

PART 3 - EXECUTION

3.01 INSTALLATION

- A. Install all valves in accordance with the manufacturer's instructions.
- B. Exercise care during installation to prevent damage to the valves and to the factory-applied lining and coating. Damaged valves including linings and coatings must be replaced. In any location where coatings have been damaged or scraped off, the area must be thoroughly cleaned and recoated using the manufacturer's recommended primer and coatings. The Contractor must submit a coating repair procedure for review and approval by the Engineer prior to performing any field coating repairs.
- C. The surface of all valves must be free from oil, grease, and dirt after installation.

- D. Install valve supports as shown in the Drawings and **Section 40 05 15 – Pipe Supports and Seismic Restraints**.
- E. Contractor must verify that all valve operating handwheels, nuts, and gearboxes are installed without obstruction and can be easily operated from the adjacent ground surface or platform. If a valve cannot be operated in the location shown, contact the Engineer prior to installation.
- F. Install stem guides in accordance with manufacturer's instruction. Stem guide spacing must not exceed 6'.

3.02 TESTING

- A. Prior to and after installation, each valve must be operated through at least two full open-close cycles the presence of the Engineer with no apparent resistance or jamming.

End of Section 40 23 01

SPECIFICATION SECTION 40 23 04
PIPING PRESSURE AND LEAKAGE TESTING

PART 1 – GENERAL

9.02 SECTION INCLUDES

JJ. Pressure and leakage testing of pipe and fittings, valves, force main and appurtenances installed as part of the Contract.

9.03 PROJECT CONDITIONS

KK. Conduct pressure and leakage testing in the presence of Owner and Engineer.

LL. Notify Owner and Engineer 48 hours in advance of testing.

MM. Provide all materials, labor, and equipment used for testing.

NN. Potable water for testing will be furnished by SPU. Contractor is responsible for obtaining hydrant permit and meter.

9.04 SUBMITTALS

A. Submit recent (i.e. within last year) calibration certificate for pressure gauge to be used for testing.

PART 2 - PRODUCTS

10.01 EQUIPMENT

OO. Provide all testing apparatus including, but not limited to, test pumps, hoses, gages, valves and fittings.

PP. Potable water for testing will be furnished by SPU. Contractor is responsible for obtaining hydrant permit and meter.

PART 3 - EXECUTION

11.01 EXECUTION

QQ. Hydrostatic test must be in accordance with the City of Seattle Standard Specifications **Section 7-17.3(3)E**. Testing is limited to the internal sewer force main piping and valves within the pump station that were installed as part of the Work. Temporarily cap or plug piping to be tested and remove caps following completion of a successful pressure test.

RR. Where connections to existing equipment or piping cannot practically be pressure tested, the Engineer, at their sole discretion, may allow specific connections to be accepted by visual inspection or other means.

SS. Ensure that all supports and restraints are securely in place prior to testing.

11.02 COMPLETION OF TESTS

TT. After all tests have been successfully completed, no further Work will be permitted on the force main, piping, valves, and appurtenances without full knowledge of Owner and Engineer. Depending on the nature of the work, additional testing and inspection may be required.

UU. All pressure testing must be successfully completed prior to beginning commissioning activities.

End of Section 40 23 04

SPECIFICATION SECTION 40 90 00
INSTRUMENT PROCESS CTRL BASIC RQMTS

PART 12 - GENERAL

12.01 SUMMARY

- A. Section Includes:
 - 1. Basic requirements for complete instrumentation system for process control.
- B. This Section includes the additional document "Instrument Certification Sheet", which contains a template sheet for documenting instrumentation certifications.
- C. Related Sections include but are not necessarily limited to:
 - 1. Division 00 - Procurement and Contracting Requirements
 - 2. Division 01 - General Requirements
 - 3. Division 26 - Electrical
 - 4. Section 26 05 00 – Electrical: Basic Requirements
 - 5. Section 26 05 19 – Low Voltage Electrical Power Conductors and Cables
 - 6. Section 40 91 10 - Primary Elements and Transmitters
 - 7. Section 40 91 16 - Magnetic Flow Meters
 - 8. Sections 40 90 05, 40 90 06 and 40 90 07 - Control Loop Descriptions

12.02 QUALITY ASSURANCE

- A. Referenced Standards:
 - 1. Canadian Standards Association (CSA).
 - 2. FM Global (FM).
 - 3. The Instrumentation, Systems, and Automation Society (ISA):
 - a. S5.1, Instrumentation Symbols and Identification.
 - b. S5.3, Graphic Symbols for Distributed Control/Shared Display Instrumentation, Logic and Computer Systems.
 - c. S5.4, Standard Instrument Loop Diagrams.
 - d. S20, Standard Specification Forms for Process Measurement and Control Instruments, Primary Elements and Control Valves.
 - 4. National Electrical Manufacturers Association (NEMA):
 - a. 250, Enclosures for Electrical Equipment (1000 Volts Maximum).
 - 5. National Fire Protection Association (NFPA):
 - a. 70, National Electrical Code (NEC).
 - b. 820, Standard for Fire Protection in Wastewater Treatment and Collection Facilities.

6. National Institute of Standards and Technology (NIST).
 7. Underwriters Laboratories, Inc. (UL):
 - a. 913, Standard for Safety, Intrinsically Safe Apparatus and Associated Apparatus for Use in Class I, II, and III, Division 1, Hazardous (Classified) Locations.
 - b. 698A, Standards for Intrinsic Safety.
 - c. 508A, Industrial Control Panels.
 8. Seattle Public Utilities, SCADA Management:
 - a. SPU Design Guidelines & Standards. Section 10 – Instrumentation and Control. SCADA.
- B. Qualifications:
1. Instrumentation subcontractor:
 - a. Experience:
 - 1) Have satisfactorily provided a control system for a minimum of 5 projects of similar magnitude and function.
- C. Miscellaneous:
1. Comply with electrical classifications and NEMA enclosure types shown on Drawings and defined in the Specifications.
 2. Equipment installation in hazardous areas shall be suitable for installation and use in hazardous areas.

12.03 DEFINITIONS

- A. Hazardous Areas: Class I, II or III areas as defined in NFPA 70.
- B. Highly Corrosive and Corrosive Areas: Rooms or areas identified on the Drawings where there is a varying degree of spillage or splashing of corrosive materials such as water, wastewater or chemical solutions; or chronic exposure to corrosive, caustic or acidic agents, chemicals, chemical fumes or chemical mixtures.
- C. Outdoor Area: Exterior locations where the equipment is normally exposed to the weather and including below grade structures, such as vaults, manholes, handholes and in-ground pump stations.
- D. Intrinsically Safe Circuit: A circuit in which any spark or thermal effect is incapable of causing ignition of a mixture of flammable or combustible material in air under test conditions as prescribed in UL 698A.
- E. Calibrate: To standardize a device so that it provides a specified response to known inputs.

12.04 SYSTEM DESCRIPTION

- A. Control System Requirements:
 1. The instrument and control system consists of all primary elements, transmitters, switches, controllers, indicators, panels, signal converters, power supplies, special or shielded cable, special grounding or isolation, auxiliaries, software,

- wiring, and other devices required to provide complete control of the facility as specified in the Contract documents.
2. SCADA control cabinet, application software for programmable automation controllers, Human Machine Interface and Operator Interface Unit will be provided, configured and programmed by the Owner.
 3. SCADA control drawings in PDF electronic format will be supplied by Owner to the Contractor after the Execution Date.
- B. All signals shall be directly linearly proportional to measured variable unless specifically noted otherwise.
- C. Single Instrumentation Subcontractor:
1. Furnish and coordinate instrumentation system through a single instrumentation subcontractor:
 - a. The instrumentation subcontractor shall be responsible for supervision of installation, final connections, calibrations, programming or configuration of instruments, preparation of Drawings, testing procedures and Operation and Maintenance Manuals, start-up, training, demonstration of substantial completion for all instruments supplied for the project.
 2. Coordinate instrumentation with other work to ensure that necessary wiring, conduits, contacts, relays, converters, and incidentals are provided in order to transmit, receive, and control necessary signals to other control elements, and the Owner's SCADA system.
- D. See **Section 40 91 10 - Primary Elements and Transmitters** for thermal dispersion type flow switches associated with the dry well supply and exhaust fans; coordinate provision mounting type and interface.

12.05 SUBMITTALS

- A. General:
1. See **Section 01 33 10 - Submittals** for requirements for the submittal process.
 2. Limit the scope of each submittal to 1 specification section:
 - a. Each submittal must be submitted under the specification section containing requirements of submittal contents.
 - b. **Do not** provide equipment submittals under **Section 40 90 00 - Instrumentation for Process Control: Basic Requirements**.
 3. Documentation of instrumentation subcontractor qualifications and experience as defined in **Paragraph 1.02.B** above.
 4. Product technical data including:
 - a. Equipment catalog cut sheets.
 - b. Instrument data sheets:
 - 1) ISA S20 or approved equal.
 - 2) Separate data sheet for each instrument.
 - c. Materials of construction.

- d. Minimum and maximum ranges, calibration information (in engineering units or as otherwise noted).
 - e. Provide a parameter setting summary sheet for each field configurable device.
 - f. Physical limits of components including temperature and pressure limits.
 - g. Size and weight.
 - h. Electrical power requirements and wiring diagrams.
 - i. NEMA rating of housings.
 - j. Submittals shall be marked with arrows to show exact features to be provided. Features and options not being provided shall be crossed out.
5. Loop diagrams for SCADA per ISA S5.4 supplied by Owner.
 6. Comprehensive set of wiring diagrams for SCADA supplied by Owner.
 7. SCADA panel fabrication drawings supplied by Owner.
 8. SCADA PAC equipment drawings supplied by Owner.
 9. Drawings, systems, and other elements are represented schematically in accordance with ISA S5.1 and ISA S5.3:
 - a. The nomenclature, tag numbers, equipment numbers, panel numbers, and related series identification contained in the Contract documents shall be employed exclusively throughout submittals.
 10. Shop Drawings for instrumentation wiring and conduit shall be integral with the electrical layout shop drawing required under **Section 26 05 00 – Electrical: Basic Requirements**. A single submittal shall be made incorporating the requirements of both of these Sections.
 11. All Shop Drawings shall be modified with as-built information/corrections, supplied by Owner.
 12. Certifications:
 - a. Documentation verifying that calibration equipment is certified with NIST traceability:
 - 1) Test equipment shall be certified within 1 year of the date of use.
 - 2) Use of equipment with expired certifications shall not be permitted.
 - 3) Calibration equipment shall be at least 3 times more accurate as the device being calibrated.
 - b. Approvals from independent testing laboratories or approval agencies, such as UL, FM or CSA:
 - 1) Certification documentation is required for all equipment for which the specifications require independent agency approval.

13. Testing reports: Source quality control reports.
- B. Operation and Maintenance Manuals:
 1. See **Section 01 33 10 - Submittals** for requirements for the submittal process:
 - a. The mechanics and administration of the submittal process.
 2. See **subparagraph 1.03.K.3 of Section 00 72 00 - General Conditions** for the content of the Project Operation and Maintenance Manual.
 3. See **Section 01 77 19 – Contract Closeout Requirements**.

12.06 SITE CONDITIONS

- A. See Material Application Schedule and Area Environmental Designation Schedule in **Section 26 05 00 - Electrical: Basic Requirements**.

PART 13 - PRODUCTS

13.01 NEMA TYPE REQUIREMENTS

- A. See Material Application Schedule and Area Environmental Designation Schedule in **Section 26 05 00 - Electrical: Basic Requirements**.
- B. Provide enclosures/housing for control system components in accordance with Material Application Schedule and Area Environmental Designation Schedule in **Section 26 05 00 - Electrical: Basic Requirements**:
 1. Areas designated as Class I hazardous, Groups A, B, C, or D as defined in NFPA 70:
 - a. NEMA Type 7 unless all electrical components within enclosure or component utilizes intrinsically safe circuitry:
 - 1) Utilize intrinsically safe circuits to the maximum extent practical and as depicted in the Contract documents.
 2. Inside control cabinet: NEMA Type 12.
 3. Areas designated to be subject to temporary submersion: NEMA 6P or 7.

13.02 PERFORMANCE AND DESIGN REQUIREMENTS

- A. Instrumentation Performance Criteria:
 1. Performance: All instruments and control devices shall perform in accordance with manufacturer's specifications.

13.03 ACCESSORIES

- A. Provide identification devices for instrumentation system components in accordance with the following:
 1. Instrumentation Equipment (e.g. flow control valves, primary elements):
 - a. Tag type:
 - 1) Outdoor and/or corrosive locations: Type A1 or B1:
 - a) Stainless steel Type A1 - Round Metal Tags:
 - (1) Size:

- (a) Diameter: 1-1/2-IN minimum.
 - (b) Thickness: 0.035-IN (20 gage) minimum.
 - (2) Fabrication:
 - (a) 3/16-IN minimum mounting hole.
 - (b) Legend stamped and filled with black coloring.
 - (3) Color:
 - (a) Natural.
 - b) Type B1 - Square Non-Metallic Tags.
 - (1) Materials: Fiberglass reinforced plastic.
 - (2) Size:
 - (a) Surface: 2 x 2-IN minimum.
 - (b) Thickness: 100 mils.
 - (3) Fabrication:
 - (a) 3/16 mounting hole.
 - (b) Legend: Preprinted and permanently embedded and fade resistant.
 - (4) Color:
 - (a) Background: Manufacturer standard or as specified.
 - (b) Lettering: Black.
 - b. Fastener:
 - 1) Type A1: Chain of the same material.
 - 2) Type B1: Stainless steel chain.
 - c. Legend:
 - 1) Letter height: 1/4-IN minimum.
 - 2) Equipment ISA designation as indicated on the Drawings (e.g. "FIT-xxx").
2. Enclosure for instrumentation and control equipment, (e.g. MCP & LCP control panels):
 - a. Tag type: Type C - Phenolic Name Plates:
 - 1) Materials: Phenolic.
 - 2) Size:
 - a) Surface: As required by text.
 - b) Thickness: 1/16-IN.
 - 3) Fabrication:

- a) Two layers laminated.
 - b) Legend engraved through top lamination into bottom lamination.
 - c) Two drilled side holes, for screw mounting.
 - 4) Color: Black top surface, white core, unless otherwise indicated.
 - b. Fastener: Screws, sealed as required to maintain enclosure UL and NEMA rating.
 - c. Legend:
 - 1) Letter height: 1/2-IN minimum.
 - 2) Equipment name (e.g. "MAIN CONTROL PANEL MCP-xxx").
3. Components inside equipment enclosure, (e.g. PLC's, control relays, contactors, and timers):
 - a. Tag type: Type D - Self-Adhesive Tape Tags:
 - 1) Materials: Vinyl tape or vinyl cloth.
 - 2) Size:
 - a) Surface: as required by text.
 - b) Thickness: 5 mils minimum.
 - 3) Fabrication:
 - a) Indoor/Outdoor grade.
 - b) Weather and UV resistant links.
 - c) Permanent adhesive.
 - d) Preprinted legend.
 - e) Wire marker to be self-laminating.
 - 4) Color: White with black lettering or as specified.
 - 5) Standards for OSHA signs: NEMA/ANSI Z535.1, NEMA/ANSI Z535.2, NEMA/ANSI Z535.3, NEMA/ANSI Z535.4, OSHA 1910.145.
 - b. Fastener: Self.
 - c. Legend:
 - 1) Letter height: 3/16-IN minimum.
 - 2) Description or function of component (e.g. "PLC-xxx" or "CR-xxx").
4. Through enclosure door mounted components (e.g. selector switches, controller digital displays):
 - a. Tag type: Type C - Phenolic Name Plates (as defined at **subparagraph 2.03.A.2.a**, above).

- b. Fastener: Screws, sealed as required to maintain enclosure UL and NEMA rating.
- c. Legend:
 - 1) Letter height: 1/4-IN minimum.
 - 2) Component ISA tag number as indicated on the Drawings (e.g. "HS-xxx").
- B. Provide corrosion resistant spacers to maintain 1/4-IN separation between equipment and mounting surface in wet areas, on below grade walls and on walls of liquid containment.

PART 14 - EXECUTION

14.01 DELIVERY, STORAGE, AND HANDLING

- A. Do not remove shipping blocks, plugs, caps, and desiccant dryers installed to protect the instrumentation during shipment until the instruments are installed and permanent connections are made.
- B. Contractor must coordinate at least 48 hours in advance with Kermit Stricklin of SPU Field Operations at (206) 615-1617 for inspection and pickup of Owner-furnished SCADA control cabinet at SPU's Operations Control Center (OCC) at 2700 Airport Way S in Seattle.
 - 1. Contractor must thoroughly inspect cabinet at OCC. Contractor must transfer materials to the Project Site. Contractor must secure, protect, and store materials in a clean and dry environment as recommended by factory until installation.
 - 2. Verify nameplate and ratings in accordance with the Contract Drawings.

14.02 INSTALLATION

- A. Wherever feasible, use bottom entry for all conduit entry to instruments and junction boxes. **Absolutely NO Top penetrations will be allowed.** Provide weep holes in conduits where necessary to prevent liquid buildup. All conduits shall be installed per the approved layout shop drawing.
- B. Install electrical components per **Division 26**.
- C. Panel-Mounted Instruments:
 - 1. Mount and wire so removal or replacement may be accomplished without interruption of service to adjacent devices.
 - 2. Locate all devices mounted inside enclosures so terminals and adjustment devices are readily accessible without use of special tools and with terminal markings clearly visible.
- D. See **Section 26 05 19 – Low Voltage Electrical Power Conductors and Cables**.

14.03 COORDINATION

- A. Coordinate with other trades for equipment sizing and mounting.
 - 1. Coordinate with mechanical HVAC supplier location and mounting method of the ventilation air flow switches specified in **Section 40 91 10 – Primary Elements and Transmitters.**

14.04 FIELD QUALITY CONTROL

- A. Maintain accurate daily log of all startup activities, calibration functions, and final setpoint adjustments.
 - 1. Documentation requirements include the utilization of the forms located at the end of this Section:
 - a. Instrument Certification Sheet.
- B. Instrumentation Calibration:
 - 1. Verify that all instruments and control devices are calibrated or programmed to provide the performance required by the Contract documents.
 - 2. Calibrate all field-mounted instruments after the device is mounted in place to assure proper installed operation.
 - 3. Calibrate in accordance with the manufacturer's specifications.
 - 4. Check the calibration of each transmitter and gage across its specified range at 0, 25, 50, 75, and 100 percent:
 - a. Check for both increasing and decreasing input signals to detect and document any hysteresis.
 - 5. Record all programmable parameters and submit with O&M documents.
 - 6. Replace any instrument which cannot be properly adjusted or calibrated.
 - 7. Stroke control valves to verify control action, feedback, and positioner settings.
 - 8. Calibration equipment shall be certified by an independent agency with traceability to NIST:
 - a. Certification shall be certified within 1 year of the date of use.
 - b. Use of equipment with expired certifications shall not be permitted.
 - 9. Calibration equipment shall be at least 3 times more accurate as the device being calibrated.
- C. Loop check-out requirements are as follows:
 - 1. Check control signal generation, transmission, reception and response for all control loops under simulated operating conditions by imposing a signal on the loop at the instrument connections:
 - a. Use actual signals where available.
 - b. Closely observe controllers, indicators, transmitters, displays, alarm and trip units, and other control components:
 - 1) Verify that readings at all loop components are in agreement.
 - 2) Make corrections as required:

- a) Following any corrections, retest the loop as before.
 2. Stroke all control valves, from the local control station and from the local operator interface.
 3. Check all interlocks to the maximum extent possible.
 4. In addition to any other as-recorded documents, record all calibration changes on all affected Contract Documents and turn over to the Owner.
- D. Provide verification of system assembly, power, ground, and I/O tests.
- E. Verify existence and measure adequacy of all grounds required for instrumentation and controls.
- F. Perform Start-up and Training as defined in **Section 01 75 00 – Commissioning and Site Acceptance.**
1. Assist Owner during testing which includes Manual & full Auto test for the complete system as specified.

End of Section 40 90 00

SPECIFICATION SECTION 40 90 05
PS 17 CONTROL LOOP DESCRIPTION

Note to designers: This section is provided as an example of a control loop description for a typical duplex VFD driven wastewater pump station. Not all elements may be relevant to a given project. Work with your SPU SCADA Engineer and Analyst when preparing this Section.

PART 15 - GENERAL

15.01 SUMMARY

- A. Section Includes:
1. Instrumentation control loops.
 2. Hard wired interlocks that are described in this and other Sections are referenced on the P&IDs and are to be provided by the Contractor unless incorporated into the Owner-supplied SCADA Panel.
 3. The intent of including this Section is to describe how the Site will operate; the Owner will use this to accomplish the programming (application software development).
 4. This Section is provided for reference only.
- B. Related Sections include but are not necessarily limited to:
1. Division 00 – Procurement and Contracting Requirements
 2. Division 01 - General Requirements
 3. Section 01 33 10 – Submittals
 4. Section 01 75 00 – Commissioning and Site Acceptance
 5. Section 40 91 10 - Primary Elements and Transmitters
 6. Section 40 91 16 – Magnetic Flow Meters

15.02 QUALITY ASSURANCE (NOT USED)

15.03 SYSTEM DESCRIPTION

- A. Instrumentation drawings in conjunction with the control strategies described below work together to clarify the pump station control system operational requirements.
- B. The Owner will provide all application software development (this includes programming of the Opto 22 PAC) required to implement the functional requirements of the control loops.
- C. The control loop descriptions provide the functional requirements of the control loops represented in the Contract documents.
- D. The control loop descriptions are not intended to be an inclusive listing of all elements and appurtenances required to execute loop functions, but are rather intended to supplement and complement the Drawings and other Specifications Sections:
1. The control loop descriptions must not be considered equal to a bill of materials.

2. The control loop descriptions' programming will be implemented by the Owner.
- E. SPU software standards will be followed for communications with this Site, including the following:
 1. Programmable Automation Controller (PAC) address assignment.
 2. Communications configuration.
- F. Process control logic will reside and be executed in the PAC as much as possible.
- G. Supervisory process control functionality will follow SPU software standards. In general, SPU staff (with appropriate security access rights) can change applicable process control, process alarm, control modes, etc. from the operator interface unit (OIU) system, the changes are communicated to the PAC, the PAC confirms back to the OIU system when the change has been implemented, and the change appears on the OIU system.
- H. Alarm management functionality will follow SPU software standards.
- I. Data collection, archiving, reporting, displaying and functionality will follow SPU software standards.
- J. OIU display layout, color conventions, navigation, security access rights, and control functionality will follow SPU software standards.
- K. HMI (at OCC) displays, functionality, and control will be identical to those of the OIU at the pump station.

PART 16 - PRODUCTS (NOT USED)

PART 17 - EXECUTION

17.01 PUMP STATION CONTROL LOOPS

- A. The following COMMON functions will follow SPU software standards:
 1. Common analog I/O functions:
 - a. Conditioning.
 - b. Alarming.
 - c. Scaling.
 - d. Process Data Logging.
 - e. Flow totalization. When associated instrument is in MAINTENANCE mode, use last good value for totalization and mark historical data accordingly.
 - f. Alarm set point dead bands.
 - g. Calculated analog values.
 - h. Instrument or equipment calibration mode (operate mode, maintenance mode, alarm inhibit, timed monitoring in maintenance mode, data collection management when in maintenance mode, etc.).

2. Common discrete I/O functions:
 - a. Alarming (alarms specified below).
 - b. Nuisance tripping.
 3. Common control functions:
 - a. Bumpless transfer (between control modes: auto, manual, local, remote, LRI modes, etc.).
 - b. Tracking of set point, process variable, equipment status (opened, closed, position, mode, etc.).
 4. Common monitoring functions:
 - a. Communications:
 - 1) Status.
 - 2) Failure.
 - 3) Power failure and restore.
 5. Common instrument functions:
 - a. Individual instrument high and low out-of-range alarming.
- B. Loop 100 – Wastewater Pumping System:
1. PID Reference: Drawing D-301, D-302
 2. Other References: Sheets 1-39
 3. Key Elements:
 - a. Pump Station Wetwell.
 - b. Level Transducers in the Wetwell (520PE/PT01).
 - c. Float Switches (520LSH03, 520LSHH04)
 - d. Wastewater Pumps (2 each, variable speed, located in the dry well, firm capacity 2,500 gpm, interlocked for single operation only).
 - e. Variable Frequency Drives (510VFD01 & 510VFD02)
 - f. Wastewater Pump discharge pipes.
 - g. Wastewater Pumps into a 10-inch Discharge Force Main.
 - h. Suction Isolation Valves (Tags 510GV01, 02)
 - i. Discharge Check Valves (Tags 510CHV01, 02)
 - j. Discharge Isolation Valves (Tags 510GV03,04)
 - k. Pump Station Bypass Vault
 - l. Pump Station Bypass Isolation Valves (Tags 560GV01, 02, 03)
 4. System description:
 - a. The pump station has two dry-pit centrifugal wastewater pumps, 510P01 and 510P02 located in the dry well.
 - b. Both pumps are 50 HP and have the same capacity.

- c. Pumps are electrically interlocked such that only one pump may run at a time under any circumstance.
 - d. Each pump is operated at variable-speed by its associated variable frequency drive (510VFD01, 02).
 - e. Each pump is equipped with a check valve, a discharge isolation valve and suction isolation valve.
 - f. The pumps discharge into a common force main that connects to the existing force main discharge into the King County system at node XXX-XXX.
5. Alarms:
- a. Pumps are not equipped with integral alarms for this station.
6. Process data logging:
- a. Trend the run status of each wastewater pump.
 - b. Trend the speed of each wastewater pump.
 - c. Trend the speed-based calculated flow of each wastewater pump.
7. Operation:
- a. General description:
 - 1) The Wastewater Discharge Pumps empty the wetwell by pumping into a common force main that discharges to node XXX-XXX
 - 2) The control intent is to maintain wet well levels at or below a given setpoint by continuously varying the pump speed within a specified range such that discharge rate matches inflow rate to the maximum extent feasible.
 - 3) The following data points will be used to control the Wastewater Discharge Pumps:
 - a) Level of water in the wetwell (520PE/PT-01)
 - 4) As the level approaches the bottom of the wetwell, the pumps will stop at the designated level.
 - 5) The PAC will utilize the pressure transducers that monitors the level in the wetwell (520PE/PT-01)
 - b. Manual control functions:
 - 1) OIU: The wastewater pumps may be operated in manual (hand) mode for pumping out the wetwell. Call selected pump at 100% speed, subject to programmed ramp times.
 - 2) OIU: Pump-Down Command: Call lead pump at 100% speed, subject to programmed ramp times.
 - 3) Key switch (HOA switch on 510MCP01): The wastewater pumps may be operated in manual (hand) for pumping out the wetwell. Call selected pump at 100% speed, subject to programmed ramp times.

- 4) PAC: None.
- c. Automatic control functions:
- 1) The operation of the wastewater pumps is controlled by the water level in the wetwell (as measured by 520PE/PT-01)
 - 2) The level in the wetwell will control the operation of the wastewater pumps by turning the pumps on if the wetwell reaches the pump on setpoint and off when the wetwell reaches the pump off set point.
 - 3) The following describes wastewater pump operation:
 - a) When the level in the wetwell (as measured by 520PE/PT-01) reaches the Lead Pump On level, the lead wastewater pump will start.
 - b) The lead pump will start at minimum speed, as programmed in the VFD settings, and will modulate speed between the minimum and maximum speeds as dictated by the PID loop, to attempt to maintain the wetwell depth at or below the Lead Pump On level.
 - (1) Pump speed is controlled through the PAC program based on wetwell level.
 - (2) VFD minimum and maximum speeds as well as pump ramp up and down speeds will be set in the VFD's during initial commissioning.
 - (3) Pump speed adjustments from PID loop must be limited to not more than once per every fifteen seconds.
 - c) When levels decrease below Lead Pump start level, the lead pump will slow to minimum speed.
 - d) When levels decrease below the Lead Pump stop level, the lead pump will stop.
 - e) Lead pump will alternate between 510P01 and 510P02 after each pumping cycle, but not less than once every 24 hours.
 - f) The PAC will call for wastewater pumps to run as shown in the following table:

**Elevation Settings
 Wetwell**

Level Status	COMMENTS	Wet Well Depth above Sump(ft)	ELEVATION (ft)
Overflow Alarm (520LSHH04)	Required report to Dept. of Ecology	21.69	14.04
520PE/PT02	Secondary Transducer Mounting Elevation	18.15	10.50
High Level Alarm (520LSH03)	Level at which Smart Relay will activate Lead pump if PAC has failed	11.15	3.50
Lead Pump on (Single Pump Level Control Target)	Level at which the lead pump starts	8.00	0.35
Lead Pump off	Normal stop setpoint Lead pump	3.30	-4.35
Low Level Alarm	Pumps will be exposed to air below this level. Stop all pumps.	2.50	-5.15
520PE/PT01	Primary Transducer Mounting Elevation	0.50	-7.15

All action levels in the above table are operator adjustable.

Variable Frequency Drive Settings

Drive Parameter	Value
Minimum speed, rev/min	780
Maximum speed, rev/min	1,120
Drive ramp up time to minimum speed, sec	15
Drive ramp down time after stop, sec	15
Drive maximum acceleration, rev/sec ²	50

These parameters are set in the drive, separately from the PAC and are not remotely operator adjustable.

- g) Each pump will stop when the level in wetwell reaches the respective pump off levels.
- h) If a pump fails, an alarm is activated, and the remaining pump will follow the sequence above as possible.
- d. Process control interlocks hard wired in pump motor controller:
 - 1) Motor Local Disconnect (Meltric Connector 510DS-01, 02): Lock out pPump run command.
 - 2) Phase Fail: Lock out both pumps.
 - 3) Motor Overload/VFD fault: Lock out Pump.
 - 4) Other pump running: Lock out Pump (Only one pump may run at a time).
 - 5) Motor Overtemperature: timeout operation until motor temperature drops below trip threshold.

- e. PAC fail control:
 - 1) If the PAC should fail the lead pumps will be controlled by the IDEC Smart relay and float switch 520LSH-031.
 - 2) Pump will pump at 100% speed for a predetermined time and then stop.
- 8. OIU indication, alarming and operator set points:
 - a. OIU Display, typical of both wastewater pumps:
 - 1) Pumps in autohand, 510HS-01/ 510HS-02.(HOA switch on 510MCP01)
 - 2) Pumps in handoff, 510HS-01/ 510HS-02. (HOA switch on 510MCP01)
 - 3) Pumps in auto, (HOA switch on 510MCP01)
 - 4)
 - 5) Motor Connected, 510DS510QL-01C/ 510DS510QL-02C
 - 6) OIU Auto/Manual.
 - 7) Running, QL-01B/ QL-02B.
 - 8) VFD Fault, QAL-01A/ QAL-02A.
 - 9) Pump 2 Interlock Active, 510QL-01D, 510QL-02D
 - 10) Motor Overtemp, 510QL-01E, 510QL-02E
 - 11) Bearing Overtemp, 510QL-01F, 510QL-02F
 - 12) Power Monitor (integral to 510VFD01/02)
 - 13) Wetwell Level Transducers. (520PE/PT-01 & 520PE/PT-02).
 - b. Alarms, typical of both wastewater pumps:
 - 1) Pump Fail to start.
 - 2) Bearing Overtemp (does not lock out pump, alarm only)
 - 3) Excessive Run (Pump runs more than 30 min)
 - 4) Pump VFD out of range of commanded speed
commanded speed out of range of allowable values.
 - 5) Pump Low Flow: Flow measured by 510FE/FIT01 is less than 50% of factory pump curve for more than 5 minutes. (Does not lock out pump, alarm only to trigger maintenance work order. No-Flow detection should be implemented within the VFD).
 - 6) Motor Disconnect Open QL-01C, 02C
 - c. Other alarms
 - 1) Overflow (520LSHH-02 tripped or 520PE/PT-02 indicates overflow) indicates facility overflow imminent or underway. Alarm on OIU and remotely.
 - d. Operator set points:

- 1) Operator Set point (Lead Start, Lead Stop), High Wet Well, Low Wet Well, Overflow).
 - e. VFD Set Points (These are set in the drive and are not operator adjustable)
 - 1) Pump Start Ramp-Up Time (seconds)
 - 2) Pump Shutdown Ramp-Down Time (seconds)
 - 3) Pump Maximum Acceleration (rev/sec²)
 - 4) Pump Minimum Speed (rev)
 - 5) Pump Maximum Speed (rev)
 - 6) Bearing maximum temperature
 - f. VFD Data Logging, (These are VFD firmware programmable and are not operator adjustable)
 - 1) Bearing temperature
 - 2) Motor current
 - 3) Motor mechanical power
 - 4) Pump efficiency
 9. Calculated Flow
 - a. Trend this value at all times. Display on OIU as calculated flow, to display only if measured flow per Loop 800 is not available.
 - b. This calculation is based on actual drive speed and uses two equations, selected based on the current wetwell level:

For wet well level < (Lead pump start level minus 0.2 ft)
 $Q = 850 \text{ gpm}$

Else
 $Q = 3.3879x - 1538.4$, where x = actual drive speed reported by the VFD.
 - c. Flow parameters shown are based on design data and must be updated using actual flow measurements made during commissioning.
- C. Loop 200 – Facility Ventilation System:
 1. PID Reference: Drawing D-301, D-302.
 2. Other References: Sheets 1-39.
 3. Key Elements:
 - a. Dry Well and Wet Well supply and exhaust ducting and balancing dampers.
 - b. Dry Well Supply Fan (510SF-10)
 - c. Dry Well Exhaust Fan (510EF-11)
 - d. Wet Well Supply Fan (520SF-20)
 - e. Wet Well Exhaust Fan (520EF-21)

- f. Dry Well Supply Flow Switch (510FSL-10)
- g. Dry Well Exhaust Flow Switch (510FSL-11)
- 4. System description:
 - a. Ventilation is provided for the dry well and wet well
 - b. The supply and exhaust fans operate continually to provide the required number of air exchanges in all vaults.
- 5. Alarms:
 - a. A visual indicator is provided to notify personnel of ventilation failure at the entry door for Dry Well.
 - b. Flow indicating switches are installed in the supply and exhaust air ducting of the Dry Well.
- 6. Process data logging:
 - 1) Trend run status of each fan (IS-10, IS-11, IS-20, IS-21).
 - 2) Trend status of each flow switch (510FSL-10, 510FSL-11).
- 7. Operation:
 - a. Manual control functions:
 - 1) OIU: None.
 - 2) PAC: None.
 - 3) Dry Well: When the breakers for Supply fans (510SF-10) and exhaust fan (510EF-11) are on the fans operate continually.
 - 4) Wetwell: When the breakers for Supply Fan (520SF-20), and exhaust fan (520EF-21) are on the fans operate continually.
 - b. Automatic control functions:
 - 1) None.
 - c. Process control interlocks:
 - 1) None.
- 8. OIU indication, alarming and operator set points:
 - a. OIU Display:
 - 1) Dry Well Supply Fan, 510SF-10, Running, IS-10.
 - 2) Dry Well Exhaust Fan, 510EF-11, Running, IS-11.
 - 3) Dry Well Supply Fan 510SF-10, Low Flow, 510FSL-10
 - 4) Dry Well Exhaust Fan, 510EF-11, Low Flow, 510FSL-11
 - 5) Wetwell Supply Fan, 520SF-20, Running, IS-20.
 - 6) Wetwell Exhaust Fan, 520EF-21, Running, IS-21.
 - b. Alarms:

- 1) Display an alarm on the OIU if flow switches indicate low ventilation flow in the Dry Well for either supply or exhaust system.
 - c. Operator Set Points:
 - 1) None.
- D. Loop 300 – Wetwell Gas Detection System (LEL):
1. PID Reference: Drawing D-301, D-302
 2. Other References: Sheets 1-39.
 3. Key Elements:
 - a. Gas detection analyzer (510AE/AIT-08).
 - b. Gas sample pump (SP-08)
 4. System description:
 - a. Air quality is continuously monitored in the wetwell for high levels of explosive gases.
 5. Process data logging:
 - 1) Gas concentrations of explosive gases (510AE/AIT-08) in the wetwell.
 6. Operation:
 - a. General description:
 - 1) Gas detectors continually monitor the air quality in the wetwell and alarm locally and remotely if poor air quality is detected.
 - b. Manual control functions:
 - 1) OIU: None.
 - 2) PAC: None.
 - c. Automatic control functions:
 - 1) When a gas monitor detects an alarm condition, discrete alarm contacts close within the unit which sends a signal to the PAC.
 - d. Process control interlocks:
 - 1) None.
 7. OIU indication, alarming and operator set points:
 - a. OIU Display:
 - 1) Display the concentration of gases read in wet well on a gas monitoring screen on the OIU.
 - b. Alarms:
 - 1) Display a gas alarm on the OIU if the gas detector indicates any gas alarm condition in the wetwell.
 - 2) Display Gas detection alarms and ventilation alarms on OIU and sent to the telemetry system.

- 3) Discrete contacts from 510AE/AIT-08, Wetwell LEL, will send a signal to the PAC in the event of an instrument fault.
 - 4) Discrete contacts from the gas Sample Pump (510SP-08) will send a signal indicating a loss of sample flow to the telemetry system.
 - c. Operator Set Points:
 - 1) None.
- E. Loop 400 – Sump Pump System:
 1. PID Reference: Drawing D-301, D-302.
 2. Other References: Sheets 1-39.
 3. Key Elements:
 - a. Dry Well sump pump (510P10).
 - b. Sump pump check valve (510CHV10)
 - c. Dry Well Flood Float Switch (510LSHH-06).
 - d. Bypass Vault sump pump (560P04)
 - e. Bypass Vault Flood Float Switch (560LSHH-05)
 4. System description:
 - a. Sump pump is located in the Dry Well.
 - b. The sump pump drains the Dry Well when water has collected in the sump.
 - c. Bypass vault sump pump is located in the bypass vault and drains the vault when water has collected in it.
 5. Alarms:
 - a. A dry well float switch (510LSHH-06) is provided for the Dry Well and will alarm if there is standing water outside of the sump area (Dry Well Flood).
 - b. If the Flood switch trips it will send an alarm through the SCADA system alerting Operations to send out a crew to pump out the Dry Well.

6. Process data logging:
 - 1) Sump Pump Run Status (IS-P100A).
 - 2) Bypass sump pump run status (IS-04)
 - 3) Dry Well Flood Switch Status (510LSHH-06)
 - 4) Bypass Vault Flood Switch Status (560LSHH-05)
7. Operation:
 - a. General description:
 - 1) One sump pump is located in the Dry Well vault.
 - 2) The sump pump is controlled by an integral float or pressure switch.
 - 3) A second sump pump is located in the bypass vault, controlled by an integral float or pressure switch.
 - b. Manual control functions:
 - 1) OIU: None.
 - 2) PAC: None.
 - c. Automatic control functions:
 - 1) Sump pumps are controlled by an integral float or pressure switch. Flood switch 510LSHH-06 does not influence sump pump controls.
 - d. Process control interlocks:
 - 1) None.
8. OIU indication, alarming and operator set points:
 - a. Alarms:
 - 1) Sump Pump Run Indicator (IS-0AP10).
 - 2) Bypass sump pump run indicator (IS-04)
 - 3) Flood alarm in dry well, 510LSHH-06.
 - 4) Bypass Vault Flood (560LSHH-05)
- F. Loops 500, 600, and 700 – Control Cabinet DC and AC Power:
 1. PID Reference: Drawing D-301.
 2. Other References: Sheets 1-39
 3. System description:
 - a. Monitor AC power supply in the main control cabinet (510PFR-07).
 - b. Monitor SCADA battery system operation.
 4. Process data logging:
 - a. DC battery voltage from 510DCUPS-01.

5. Operation:
 - a. General description:
 - 1) Monitor DC and AC power systems.
 - b. Manual control functions:
 - 1) OIU: None.
 - 2) PAC: None.
 - c. Automatic control functions:
 - 1) None.
 - d. Process control interlocks:
 - 1) None.
6. OIU indication, alarming and operator set points:
 - a. OIU Display:
 - 1) 510DCUPS-01, Battery Voltage, 510EE-01.
 - 2) 510DCUPS-01, Replace Battery, YI-01A.
 - 3) 510DCUPS-01, Buffering, YI-01B.
 - 4) 510DCUPS-01, Ready, YI-01C.
 - b. Alarms:
 - 1) AC Utility Power Fail.
 - 2) 510DCUPS-01:
 - 3) Replace Battery, YI-01A.
 - c. Operator set points:
 - 1) None.
- G. Loop 800 – Flow Monitoring:
 1. P&ID Reference: Drawing D-301, D-302.
 2. Other References: Sheets 1-39
 3. Key Elements:
 - a. Flow Meter (510FE/FIT-09)
 - b. Wastewater Forcemain (EQ# 665307)
 4. System description:
 - a. This loop monitors the flow rate in the Wastewater Forcemain (EQ# 665307)
 5. Process data logging:
 - a. The following points are logged to the process data historian:
 - 1) 510FE/FIT-09 (electromagnetic flow meter) flow signals measuring flow rate in wastewater forcemain output signal to PAC.

6. Operation:
 - a. General description:
 - 1) Monitor flow rate in the Wastewater Forcemain.
 - b. Manual control functions:
 - 1) OIU: None.
 - 2) PAC: None.
 - c. Automatic control functions:
 - 1) None.
 7. OIU indication, alarming and operator set points:
 - a. OIU Display:
 - 1) Actual Flow
 - 2) Rolling Daily Totalized Flow.
 - b. Alarms:
 - 1) Flow Meter Out of Range.
 - 2) Flow Meter Fault.
- H. Loop 900 – Generator, MTS, and MCC PowerSPD
1. Key Elements:
 - a. Generator (210GEN01)
 - b. Automatic Transfer Switch (100ATS01)
 - c. Motor Control Center Surge Protection (510SPD01)
 - d. Power Monitor (integral to 510VFD01/02)
 2. System Description:
 - a. Monitor generator operation through a digital communication bus network with discrete output contacts for generator running and in auto status and generator low fuel and fail alarms.
 - b. Monitor ATS through a digital communication bus network with discrete output contacts for load connection indication asof switch position in utility/normal or generator power, loss of utility power,; and discrete input contact for generator exercise.
 - c. Monitor MCC SPD statuspower monitor through a digital communication bus network with analog output for power and a discrete output contractfor power loss.
 3. Process Data Logging (future):
 - a. SPU standard power usage data logging.
 4. Operation:
 - a. Manual Control Functions:
 - 1) OIU/PAC: Exercise Generator per SPU standard procedure.

- b. Automatic Control Functions (future):
 - 1) OIU/PAC: Exercise Generator per SPU standard procedure.
 - c. Process Control Interlocks: None.
5. OIU Indication, Alarming and Operator Set Points:
- a. OIU Display:
 - 1) Generator:
 - a) Generator Running (210YI-01A)
 - b) Generator in Auto (210YI-01B)
 - c) Low Fuel (210LSL-01C)
 - d) Fail (210QAL-01D)
 - e) Runtime current.
 - f) Runtime rolling weekly total
 - g) Data read over digital communication per SPU standard procedure (e.g. battery voltage, fuel level).
 - 2) Automatic Transfer Switch:
 - a) ATS on Utility/Normal (100ZS-01B)
 - b) ATS on generator (100ZS-01C)
 - c) Utility Power Loss (100PFR-01A)
 - d) Data read over digital communication per SPU standard procedure (e.g. transfer status, line power, output current)
 - 3) Station Power MonitorStatus:
 - a) SPD active Power(510SPD01)
 - b) Data read over digital communication per SPU standard procedure (e.g. average current, phase current).
 - b. Alarms:
 - 1) Utility Power Loss
 - 2) Digital communication loss with ATS
 - 3) Generator:
 - a) Low fuel
 - b) Generator fail
 - c) Alarms read over digital communication per SPU standard procedure (e.g. phase imbalance, overvoltage, undervoltage, overcurrent)
 - d) Digital communication loss with Generator.
 - 4) Station Power MonitorStatus:

- a) Alarms read over digital communication per SPU standard procedure (e.g. phase imbalance, overvoltage, undervoltage, overcurrent)
 - b) Digital communication loss with Power Monitor.
 - c) SPD active
- c. Operator Set Points: None.

End of Section 40 90 05

SPECIFICATION SECTION 40 91 10
PRIMARY ELEMENTS & TRANSMITTERS

PART 1 - GENERAL

1.01 SUMMARY

- A. Section Includes:
 - 1. Analytical Components
 - 2. Float Level Switches
 - 3. Pressure Level Transducers
 - 4. Intrinsic Safety Barriers
 - 5. Thermal Dispersion Flow Switches
- B. Related Sections include but are not necessarily limited to:
 - 1. Division 00 - Procurement and Contracting Requirements
 - 2. Division 01 - General Requirements

1.02 QUALITY ASSURANCE

- A. Referenced Standards:
 - 1. National Electrical Manufacturers Association (NEMA):
 - a. 250, Enclosures for Electrical Equipment (1000 Volts Maximum).

1.03 SYSTEM DESCRIPTION

- A. The instruments specified in this Section are the primary element components and accessories shown on the Drawings and as required for a complete installation.
 - 1. The Ultima XIR gas monitor must provide continuous monitoring of hazardous gas using microprocessor based infrared gas detection method. It must be integrated with SCADA for remote and local display and monitoring methane and/or other possible combustible gases in the wet well.
 - 2. Level pressure transducers and other level float switches must be integrated with SCADA to remotely and locally control and monitor the facility operation. Contractor must provide and install these instruments and route conduits and cables to SCADA panel.

1.04 RELATED SECTIONS

- A. Related Sections. The work in the following Sections is related to the work in this Section.
 - 1. Section 01 33 10 – Submittals
- B. Other Sections, not referenced above, may also be related to the proper performance of this Work. It is the Contractor's responsibility to perform all the work required by the Contract documents.

- C. **Section 41 91 10A** at the end of this Section contains Shop Drawings for use in submittals for the Combustible Gas Detector described in **Article 2.04**.

1.05 SUBMITTALS

- A. Shop Drawings:
 - 1. Required for Combustible Gas Detector.
 - 2. See **Section 01 33 10 - Submittals** for requirements for the submittal process.
- B. Operation and Maintenance Manuals:
 - 1. See **Section 01 33 10 - Submittals** for requirements for the mechanics and administration of the submittal process.
 - 2. See **subparagraph 1.03.K.3 of Section 00 73 00 – Supplementary Conditions** for the content of the Project Operation and Maintenance Manual.
 - 3. See **Section 01 77 19 – Contract Closeout Requirements**.

PART 2 - PRODUCTS

2.01 ACCEPTABLE MANUFACTURERS

- A. Subject to compliance with the Contract documents, the manufacturers listed in this Section describing the elements are acceptable.
- B. Submit request for substitution in accordance with **Section 01 33 10 – Submittals**.

2.02 INTRINSIC SAFETY BARRIERS

- A. Acceptable Manufacturers:
 - 1. Manufactured by PEPPERL + FUCHS Barriers:
 - a. KFD2-SR2-EX2W for discrete signal sensors
 - b. KFD2-STC4-EX2 for analog signal sensors
 - 2. Or approved equal.

2.03 LEVEL INSTRUMENTS AND ACCESSORIES

- A. Submersible Pressure Level Transducers and Transmitters:
 - 6. Acceptable Manufacturers:
 - a. Pressure Systems, Inc.
 - 1) KPSI 750 10PSI for 520PT/PE01 at all sites.
[Designer to verify appropriate range for transducer]
 - b. Or approved equal.
 - 7. Materials:
 - a. Sensor body: Stainless Steel.
 - b. Sensing diaphragm: elastomeric, Teflon coated.
 - c. Cable: polyurethane strengthened with Kevlar.

8. Design and fabrication:
 - a. Submersible pressure transmitter with a piezoresistive-micromachined silicon strain gauge type sensor.
 - b. Flush polytetrafluorethylene-coated elastomeric diaphragm.
 - c. Pressure port with flush, polytetrafluorethylene-coated elastomeric diaphragm and fluid fill to reduce grease or biosolids buildup.
 - d. In addition to electrical conductors, the sensor support cable contains a tube which is vented to atmosphere to offset changes in barometric pressure. **(Caution: Do Not cut or shorten cable as this has a manufacturer sealed end with integral fuse).**
 - e. Provide sensor termination enclosure with micro filter assembly to permit barometric reference, and a replaceable desiccant module to keep vent tube free from moisture.
 - f. Operating range: sufficient to handle scale shown in schedule below. Four times overpressure protection. Custom calibrations will not be accepted.
 - g. Loop-powered (2-wire) device with 4-20 mA DC output and 9-32 VDC excitation.
 - h. Continuous cable to control cabinet (no splices) including 10 feet of spare length coiled in the field, no exceptions.
 - i. Accuracy: +/- .25 percent of full scale.
 - j. Temperature effects: +/- 1.5 percent of full scale.
 - k. Relative humidity: 0 to 100 percent.
 - l. Operating temperature range: -5 to 140 DegF.
 - m. Diameter: 4.1-IN max.
 - n. UL listed: Intrinsically safe.

9. Schedule:

<u>PUMP STATION</u>	<u>TAG NUMBER</u>	<u>SERVICE</u>	<u>SCALE (PSI)</u>	<u>MOUNTING ELEVATION</u>	<u>MOUNT</u>

10. Mountings:
 - a. See mounting detail and notes indicated on contract drawings for mounting for sensors in wet well per design details on the Drawings.
 - b. Reuse existing mounting bracket in wet well for mounting primary pressure transducer.

- c. Provide minimum of 10-feet of spare cable coiled and secured inside maintenance hole and wet well hatch to facilitate easy maintenance of the instruments. The Contractor is responsible for determining the appropriate cable length to order.
- d. Do not cut manufacturers cable to length if cable is too long. Store excess cable in maintenance hole or wet well.

I. Float Level Switches:

- 1. Acceptable manufacturers:
 - a. MJK North America, Model 7030.
 - b. Anchor Scientific Inc. Eco-Float.
 - c. Or approved equal.
- 2. Materials:
 - a. Float material: Polypropylene or Teflon coated type 316 stainless steel or approved equal.
 - b. Cable jacket: PVC, neoprene or approved equal.
 - c. Cable clamp: Polypropylene or 316 stainless steel.
- 3. Design and fabrication:
 - a. Sealed mercury-free switch in float.
 - b. Break resistant cable.
 - c. Provide switch complete with continuous flexible electrical cable to intrinsic barrier junction box (no splices) including 10 feet of spare length coiled in the field, no exceptions.
 - d. SPDT contact rated at 4.5 amp at 120 Vac.
 - e. Direct acting float switch:
 - 1) Switch actuates, contact opens on rising level.
 - 2) Switch de-actuates when liquid falls 1-IN below actuation level.
 - f. Terminate cables in intrinsic barrier junction box.
 - g. Install floats per Drawing details and as noted in this Section.
 - h. Provide SST or non-corrosive mounting hardware as required for installation.
- 4. Schedule:

<u>PUMP STATION</u>	<u>TAG NUMBER</u>	<u>SERVICE</u>	<u>CONTACT: NC OPEN ON RISING</u>	<u>SET POINT ELEVATION</u>

<u>PUMP STATION</u>	<u>TAG NUMBER</u>	<u>SERVICE</u>	<u>CONTACT: NC OPEN ON RISING</u>	<u>SET POINT ELEVATION</u>

5. Mounting:
 - a. Minimum of 10-feet of spare cable must be coiled and secured inside wet well to facilitate easy removal of instruments for maintenance.

- J. Building Flood Level Switches:
 1. Acceptable Manufacturers:
 - a. Gems: Model LS-1900 Series
 - b. Or approved equal.
 - c. Schedule:
 - 1) All Pump Stations:
 - a) 510LSHH06
 2. Design and Fabrication:
 - a. Design: float must be easily accessible to be manually hand actuated for testing purposes without use of any tools.
 - b. Action: Set float to be NC, open on rising level. A liquid rise of 3/8-inch from rest must cause the switch to change state.
 - c. Reset: Automatic reset when liquid level drops 1/16-inch.
 - d. Designed for sensing flood conditions as an integral and complete system.
 - e. Provide junction box and mounting hardware per Material Application Schedule and Area Environmental Designation Schedule.
 - f. Operating Range: 1 to 180 DegF with 0 to 100 percent relative humidity.
 - g. Contacts Rating: 0.50A at 24VDC.

3. Mounting:
 - a. Dry wells, within 5 feet of the sump, or as otherwise shown on the Drawings.
 - b. One- and one-half inches above finished floor (AFF).

2.04 ANALYTICAL COMPONENTS

A. Combustible Gas Detectors:

1. Acceptable manufacturers:
 - a. MSA:
 - 1) Ultima X5000 Series Gas Monitors:
 - a) Combustible Gas:
 - (1) Sensor Type: LEL IR Methane.
 - (2) Range: 0 – 100% LEL.
 - 2) No like, equivalent or or-equal item is acceptable.
 - 3) Shop Drawings showing MSA gas detector design requirements are included in **Section 40 91 10A** at the end of this Section.
2. System Assembly:
 - a. Order a complete system assembly mounted on back board from supplier by MSA drawing number. See schedule.
 - 1) Assembly must consist of:
 - a) Analytical instrument(s).
 - b) Sample pump.
 - c) Filter.
 - d) Calibration Tee.
 - e) Valves and tubing.
3. Sensor/Transmitter Requirements:
 - a. Infrared Combustible (IR) Sensor/Transmitters:
 - 1) Capable of calibration without gas. Capable of performing a full calibration by zero adjustment only.
 - 2) Must detect for an above 100 percent LEL condition (over-range). This condition must be indicated on the front panel LCD.
 - 3) The IR sensor/transmitter must not contain a flashback arrestor.
 - 4) Gas check without alternate calibration or gas check fittings or cap.
 - b. Operating Requirements:
 - 1) Temperature range: -40 to 140 DegF.
 - 2) Relative humidity range: 0-95 percent non-condensing.

- 3) Operating Voltage: 10-30 VDC.
 - 4) Sensor/transmitter wiring configurations: 3-wire cable.
 - 5) Set-up and start-up of the sensor/transmitter will be so that the enclosure need not be opened during this process.
 - 6) Sensor/transmitter must contain no pots, jumpers or switches.
 - 7) Transmitter output signal: 4 to 20mA HART capable of operating into a 600-ohm load.
 - 8) Sensor/transmitter must allow for full range scaling of the 4-20mA-output signal.
 - 9) Sensor/transmitter will be capable of storing and displaying average, minimum and maximum gas concentrations over selected periods of time.
 - 10) The sensor/transmitter will give an indication of when sensor is nearing the end of its useful life by means of the front panel LCD. This indication that the sensor is nearing its useful life will be based on the sensor output. It must not be based on the time the sensor was in service.
 - 11) The sensor/transmitter units can be located remote from a monitor/readout unit by up to 100 meters via properly gauge wire.
 - 12) Accuracy:
 - a) IR Combustible Gas Methane:
 - (1) Linearity: ± 3 percent LEL < 50%. Repeatability: $\pm 2\%$ FS.
 - (2) Linearity: ± 5 percent LEL, >50 %. Repeatability: $\pm 2\%$ FS.
 - 13) Minimum detector response time when exposed to 100 percent LEL gas concentration (both types sensors):
 - a) 10 seconds to 50 percent LEL.
 - b) 30 seconds to 90 percent LEL.
 - 14) Store calibration data in nonvolatile memory or back up with battery.
 - 15) HART communication.
- c. Sensor/Transmitter Display:
- 1) Local display to indicate the gas type being monitored and the concentration of gas present. The display will alternate between the gas type (1 second) and gas concentration (5 seconds). The display will be visible from a minimum of 5-feet and will be present always and will not require being turned on or off. This readout

- will be three, one half-inch (3-1/2") digit Liquid Crystal Displays (LCD).
- 2) Sensor/transmitter display must indicate all diagnostic check/fault conditions with a scrolling message detailing the condition. Error codes must not be used.
 - 3) Sensor/transmitter will display 3 levels of alarm. Alarm levels will be adjustable by means of a handheld infrared controller or a HART hand-held communicator.
 - 4) Transmitter Display mounting height to be approximately 5-feet above the finished floor.
- d. Smart Sensor Technology:
- 1) Sensors must be contained in sensor modules mounted external to the main enclosure. All sensor modules must have the capability of replacement while the unit is under power (hazardous areas) without the need for tools.
 - 2) Sensor modules must contain all relevant sensor information within the module. This information must include sensor manufacturer date, gas type, gas range, calibration data, and default relay parameters.
 - 3) Sensor module must store all calibration data so that the module may be calibrated off site and installed in the field without the necessity of re-calibration. The sensor module must not require a battery or power source to store this data.
- e. Transmitter LED's and Relays:
- 1) Sensor/transmitter must have optional LED's, viewable from 50 feet, minimum. The LED's must operate as follows:
 - a) Solid green LED – normal operation (measure mode).
 - b) Solid red LED – fault condition.
 - c) Blinking red LED – alarm condition.
 - 2) Sensor/transmitter must have 3 SPDT relays. Relays must be rated 5 amps at 30 VDC and consist of 2 for alarm levels and 1 for instrument fault. All relay contact activation will be monitored. If the relay cannot activate for any reason, the trouble relay will change state. All relays must be field selectable through a non-intrusive hand-held wireless remote-control unit (Controller) or a HART hand-held communicator. Selectable features include:
 - a) Alarm level.
 - b) Latching / Non-latching.
 - c) Upscale / Downscale.
 - d) Normally-opened / Normally-closed.
 - e) Energized / De-energized.

- 3) Relay contacts must be normally energized (normally closed); contacts must open in the event of a warning, alarm or trouble condition.
- f. Non-Intrusive Calibration:
 - 1) All sensor/transmitters can be calibrated without opening any enclosures.
 - 2) By means of a touch interface for tool free operation. Two EZ touch buttons on the face of the display can be used to navigate through the menu structure. The display of the sensor/transmitter will instruct the user on when to apply zero and span gas. The sensor/transmitter will automatically adjust its internal settings to the proper calibration values without further intervention by the user. Upon completion of a successful calibration, the sensor transmitter will exit the calibration mode. Date stamp of last successful calibration will be retained in the sensor/transmitter internal memory, with capability to be displayed on LCD. If calibration is unsuccessful for any reason, the display must show an unsuccessful calibration attempt and revert to its previous calibration settings. Use of flashlight type devices, magnets or clamp-on devices to achieve calibration is not acceptable.
 - 3) This device has Bluetooth capability. Contractor is to ensure that the Bluetooth capability has been disabled upon completion of commissioning.
 - 4) The sensor/transmitter will not be affected by low level ambient light either natural or man-made.
4. Sensor Enclosure and Mounting:
 - a. Enclosure:
 - 1) The sensor/transmitter will be in a 316-stainless steel enclosure suitable for location in Class I, Division 1, Groups B, C & D classified areas.
 - 2) The enclosure must have a minimum of 4 entries, allowing for flexible mounting options for sensor, power, signal, and optional relay wiring.
 - 3) The enclosure must offer a means to mount without using an entryway.
 - b. Mounting:
 - 1) Sensor element and transmitter must be mounted in dry well with sample pumped via stainless steel tubing from the Class I, Division 1 location.
 - 2) The back portion of the transmitter enclosure must be separate from the electronics, allowing for mounting and wiring of the unit without the electronics present.
 - 3) A mounting bracket must be used which mounts the sensor/transmitter to a wall or similar structure.

- 4) The mounting bracket must attach to the sensor/transmitter via two tapped and threaded holes on the rear of the sensor/transmitter. There must be no brackets or clamps to secure this strap to the sensor/transmitter.
 - 5) Sensor/transmitter mounting height must be:
 - a) Mount Gas Sensor Panel center line: 54 inches above finished floor.
5. Approvals: UL Class I, Division 1, Groups A, B, C, and D.
6. Accessories and Ancillary Equipment:
- a. Calibration Gas Kit:
 - 1) Calibration kits must be furnished complete with all tubing, regulators, fittings, communication devices, and accessories required to calibrate sensors.
 - 2) Calibration kit must utilize non-intrusive means of calibrating sensors/transmitters.
 - 3) Provide 1 full cylinders of calibration check gas:
 - a) Cylinder size: 98 liters.
 - b. Ultima X Sampling Module:
 - 1) MSA part number: 10043264 DC style sampling pump, 12-24 VDC.
 - 2) Draws a gas sample from a monitored area through a sample line to the Ultima X Gas Monitor sensor.
 - 3) Samples from a remote (max 100 feet) or inaccessible area such as wet wells possibly containing hazardous gas.
 - 4) When using Ultima XIR Gas Monitor, locate the XIR sensor on the exhaust side of the sample module to ensure the most accurate readings. (The 3-way valve from the XIR flow cap must be installed on the inlet side of the pump).
 - 5) Performance Specifications for the Ultima X Sampling Module – Pump Model:
 - a) Maximum Power Consumption: 8.5 watts at 9 to 30 VDC.
 - b) Cable Requirements: Four conductor, 18 AWG.
 - c) Sample Transit Time: 30 seconds at 0.5 LPM with 50 feet (15.25 meters) of .180 ID sample tubing.
 - d) Nominal Sample Flow Rate: 2 CFH (1 LPM).
 - e) Maximum Sample Tubing Length: 100 feet (30 meters).
 - f) Maximum Exhaust Tubing Length: 20 feet (6 meters).
 - g) Inlet Fitting: ¼" (6.35 mm) OD Tubing Fitting.

- h) Exhaust Fitting: ¼" (6.35 mm) OD Tubing Fitting.
 - i) Calibration Fitting: ¼" (6.35 mm) OD Barbed Fitting.
 - j) Overall Dimensions: 9" x 6" x 5" (228.5 cm x 152.4 cm x 127 cm).
 - k) Weight: 4.5 lbs. (2 kg).
 - l) Rating: Explosion proof enclosure, Class 1, Groups A, B, C and D, Division 1 Hazardous Locations.
 - m) Electrical Entry: ¾-IN-14 NPT.
 - n) Flow Fail Relay: SPDT at 0.6 Amps, 125 Volts AC or 110 Volts DC at 2.0 Amps, 30 Volts DC.
 - o) Temperature Range: -4° to 122° (-20° to 55°C).
 - p) Humidity: 15 to 95% RH, Non-condensing.
- c. Flow Caps:
- 1) Designed to force sample gas past sensor head when sample pump is used:
 - a) Flow Cap for MSA IR LEL sensor: 10042600
 - b) Include in XIR Order number position '9' enter as 1.
- d. Filters:
- 1) Use with sample pump.
 - 2) High capacity particulate and hydrophobic in-line filter part number: MSA 637921.
 - 3) Flow sequence for LEL: high capacity particulate and hydrophobic in-line filter, sample pump, sensor.
7. Sensing Element Warranty:
- a. The XIR sensing elements (sensors) will have an expected sensor life of 10 years. The Contractor will completely replace brand-new sensors including labor at no cost to SPU if any sensor fails within the first year.
8. Schedule:

<u>PUMP STATION</u>	<u>TAG NO</u>	<u>APPLICATION</u>	<u>GAS</u>	<u>RANGE</u>	<u>SETPOINT ALARM</u>	<u>MSA DRAWING</u>

* NOTE: These items are long lead. 6 – 8 weeks + shipping time.

Exclusive local vendor for MSA Products is:

C.B. Pacific
 909 7th Ave, Suite 201

Kirkland, WA 98033

Contact Jim Lawrence, jim.lawrence@cb-pacific.com, 425-822-1702.

2.05 FLOW COMPONENTS

- A. Thermal Dispersion Type Flow Switches:
 - 1. Acceptable manufacturers and models:
 - a. Ameritrol Inc. FX Series.
 - b. Or approved equal.
 - 2. Materials:
 - a. Wetted surfaces:
 - 1) 316 stainless steel.
 - b. Housing:
 - 1) Powder Coated Explosion Proof.
 - 2) NEMA 4X
 - 3. Design and fabrication:
 - a. Repeatability: 0.5% of maximum flow rating at Constant Conditions.
 - b. Single switch point.
 - c. Response time:
 - 1) No Flow to Flow: From 3 seconds.
 - 2) Flow to No Flow: From 8 seconds.
 - d. Operating temperature: -50° to 150°F (-46° to 65°C)
 - e. Operating Pressure:
 - 1) Full vacuum to 4000 psig (675 bar).
 - f. Process connection: ¾" NMPT. Other options available.
 - g. Insertion length: As required by manufacturer for duct size.
 - h. Power input: 24 VDC.
 - i. Relay output: SPDT 3 amps @ 250 VAC.
 - j. Conduit entry: 1" FNPT.
 - k. Approval:
 - 1) UL/CSA Explosion proof.
- B. Coordination:
 - 1. Coordinate with **Section 23 34 01 – Ventilation Fans, Ductwork, and Fittings** and mechanical supplier for proper mounting and additional information.
 - 2. Air flow switches must be mounted a minimum of 5 feet above finished floor (AFF).
- C. Accessories and Ancillary Equipment:

- 1. Calibration Kit:
 - a. Provide one (1) Flow Switch Calibrator, model number MC-5
- D. Schedule:

<u>LOCATION</u>				
<u>TAG NUMBER</u>	<u>APPLICATION</u>	<u>FLUID</u>	<u>DUCT DIAMETER</u>	<u>LOW FLOW SETPOINT</u>

2.06 INTRINSIC SAFETY DEVICES

- A. Intrinsic Safety Isolators:
 - 1. Acceptable Manufacturers:
 - a. Pepperl & Fuchs.
 - b. Or approved equal.
 - 2. Design and Fabrication:
 - a. Uses a low-power, electrically isolated to safely interface with devices located in hazardous areas.
 - b. Provided with green and red LED for indication of module and field circuit status.
 - c. Interface as required by application.
 - d. External power: 24V DC.
 - e. Pole reversal protection.
 - f. Captured, self-opening screw terminals.
 - g. Response time: less than 20ms.
 - h. Galvanic isolation:
 - 1) Input/Output: 1,500V.
 - 2) Input/external supply: 1,500V.
 - 3) Output/External supply: 500V.
 - i. Radio interference suppression: Class A.
 - j. Housing material: polyimide.
 - k. Operating temperature: -20 to +60 DegC.
 - l. DIN rail mounting.

- m. Grounding method: not required.
 - n. Testing laboratory approvals: FM or UL.
- B. Loop Isolators:
- 1. Acceptable manufacturers:
 - a. Pepperl & Fuchs (model KFD2-STC4-Ex2).
 - b. Or approved equal.
 - 2. Design and fabrication:
 - a. Solid state electronics.
 - b. Transmit analog output signal directly proportional to measured input signal.
 - c. Power source: 24 Vdc.
 - d. Analog input: 4-20 mA DC.
 - e. Output signal: 4-20 mA DC into 1400 ohms.
 - f. Impedance:
 - 1) Voltage input: 10 Meg.
 - 2) Current input: 50 ohms.
 - 3) Voltage output: 1 ohm.
 - 4) Current output: 1650 ohms.
 - g. Accuracy: Better than ± 0.10 percent of span.
 - h. Isolation: Up to 500 V rms (input, output and case).
 - i. Temperature effect: ± 0.0025 percent of span per DegF.
 - j. Ambient temperature range: 0-140 DegF.
 - k. Factory calibrated.
 - l. FM or UL listed.
- C. Isolated Barrier (where required):
- 1. Acceptable manufacturers:
 - a. Pepperl & Fuchs (model KFD2-SR2-Ex2W).
 - b. Or approved equal.

2. Design and fabrication:
 - a. 2 channel isolated barrier.
 - b. 24 VDC supply.
 - c. Dry contact or NAMUR inputs.
 - d. Relay contact output
 - e. Line fault detection.
 - f. Reversible mode operation.
 - g. Power consumption: < 1.3 W.
 - h. DIN rail mounting.
 - i. Ambient temperature range: -4-140 DegF.
 - j. Hazardous area connection: terminals 1, 2, 3, 4, 5, 6.
 - k. Safe area connection: terminals 7, 8, 9, 10, 11, 12
 - l. Power connection: terminals 14, 15.
 - m. Protection degree: IP20.
 - n. FM or UL listed.

2.07 ACCESSORIES

- A. Furnish all mounting brackets, expansion rings, hardware and appurtenances required for mounting primary elements and transmitters:
 1. Materials, unless otherwise specified, must be as follows:
 - a. Bolts, nuts, washers, expansion anchors: 316 stainless steel.
 - b. Mounting brackets and expansion rings:
 - 1) Standard: 316 stainless steel.
 - 2) Highly corrosive areas: Aluminum.
 - c. Mounting plates, angles:
 - 1) Standard: Stainless steel.
 - 2) Corrosive areas: 316 stainless steel.
- B. Provide handheld communicator compatible with all transmitters furnished:
 1. Handheld communicator must provide capability to check calibration, change transmitter range, and provide diagnostics.
 2. If these features are not provided with the transmitter, the hand-held communicator is not required.
- C. Cable lengths between sensors and transmitters must be continuous (without splices) and as required to accommodate locations as shown on Drawings and by the installation, no exceptions.
- D. Provide or re-use the existing windowed barrier junction box of sufficient size to mount the Intrinsic Safety Devices in and meet NFPA 500 code.

2.08 PIPE, TUBING AND FITTINGS

A. Stainless Steel and Tygon Plastic Tubing:

1. I&C Contractor must coordinate with General and/or Mechanical Contractor to ensure that the MSA Gas Analyzer is installed following this Section and to ensure a leak free system.
2. Acceptable Manufacturers:
 - a. Tubing and fittings:
 - 1) Parker CPI.
 - 2) US Plastics Corp.
 - 3) Swagelok.
3. Instrument Tubing and Fittings:
 - a. Tubing:
 - 1) ASTM A269, 316 Stainless Steel.
 - a) Seamless.
 - b) Fully annealed.
 - c) Maximum hardness: 80 Rb.
 - d) Free from surface scratches and imperfections.
 - e) Diameter: 1/2 IN OD from Wet Well reduced to 1/4 IN to instrument.
 - f) Wall thickness:
 - (1) Meet requirements of ASME B31.1, Paragraph 122.3.
 - 2) Tygon® Norprene® Tubing:
 - a) Type A-60-G Industrial Grade.
 - b) Low gas permeability.
 - c) UV and ozone resistant.
 - d) Temperature range: -75°F to 275°F.
 - e) Minimum size: 1/4" I.D. x 3/8" O.D.
 - b. Fittings:
 - 1) Stainless steel.
 - 2) Compression type.
 - 3) Flared fittings will not be accepted.

PART 3 - EXECUTION

3.01 INSTALLATION

- A. Install products in accordance with manufacturer's instructions.

- B. Install instrument mounting level and plumb.
- C. Locate and install instruments as shown on the Drawings and approved shop drawing submittals. Instruments must be free of vibration and interference with other piping, conduit, or equipment, and free of water/splash exposure from operating equipment.
- D. Keep foreign matter out of the system.
- E. Plug all open ends and connections to keep out contaminants.
- F. Threaded Connection Seals:
 - 1. Use Tite-Seal or acceptable alternate.
 - 2. Use of lead base pipe dope or Teflon tape is not acceptable.
 - 3. Do not apply Tite-Seal to tubing threads of compression fittings.
- G. Instrument Mounting:
 - 1. Mount instruments where they will be accessible from fixed ladders, platforms, or grade wherever possible.
 - 2. Float switches to be wired in fail safe mode, NC contacts.
 - 3. Refer to instruments' manual and typical mounting detail as indicated on Drawings.
 - 4. Mount all local indicating instruments with face forward toward the normal operating or access area, within reading distance, and in the line of sight.
 - 5. Mount to provide:
 - a. Protection from heat, shock, and vibrations.
 - b. Accessibility for maintenance.
 - c. Freedom from interference with piping, conduit and equipment.
- H. Cable:
 - 1. Provide 10 feet minimum spare length of neatly coiled cable near instrument for each sensor or transmitter.
 - 2. Factory supplied cables must not be cut to reduce cable lengths. Store excess cable in wet well or maintenance holes neatly coiled and supported.

3.02 TRAINING

- A. Provide an on-site training in accordance with manufacturer's recommendations and **Section 01 75 00 – Commissioning and Site Acceptance** and **Section 26 05 00 – Electrical: Basic Requirements**.
 - 1. Equipment performance specifications.
 - 2. Transmitter programming and configuration.
 - 3. Calibration.
 - 4. Equipment operation, maintenance, and troubleshooting.

End of Section 40 91 10

SPECIFICATION SECTION 40 91 16

MAGNETIC FLOW METER

PART 1 - GENERAL

3.03 SUMMARY

- A. Section Includes:
 - 1. Flanged-body magnetic flow meter for permanent installations.
- B. Related Sections include but are not necessarily limited to:
 - 1. Division 00 - Procurement and Contracting Requirements
 - 2. Division 01 - General Requirements
 - 3. Section 26 05 00 – Electrical: Basic Requirements
 - 4. Section 26 08 13 - Acceptance Testing

3.04 QUALITY ASSURANCE

- A. Referenced Standards:
 - 1. American Iron and Steel Institute (AISI).
 - 2. American National Standards Institute (ANSI).
 - 3. American Society of Mechanical Engineers (ASME):
 - a. B16.5, Pipe Flanges and Flanged Fittings.
 - b. B31.1, Power Piping.
 - 4. National Electrical Manufacturers Association (NEMA)
- B. Manufacture instruments facilities certified to the quality standards of ISO Standard 9001.

1.03 DELIVERY, STORAGE, AND HANDLING

- A. Store instruments in a dedicated structure with space conditioning to meet the recommended storage requirements provided by the Manufacturer.
- B. Any instruments that are not stored in strict conformance with the Manufacturer's recommendation must be replaced. Sensitive electronic components must be protected from dust, rain, and direct sunlight.
- C. Unpacking and handling of flow meter must be done as recommended by the manufacturer. Do not lift or handle the spool from its amplifier box or cables as this may cause internal damage. Rig lifting straps from both flanges or as otherwise recommended by the manufacturer to ensure even weight distribution.

1.04 CALIBRATION AND WARRANTY

- A. The magnetic flow meters must be factory calibrated on an approved test stand with certified accuracy traceable to NIST, compliant with the ISO 17025 standard, and third-party accreditation by a national verification agency such as A2LA.

- B. The flow meter must be calibrated by the Manufacturer. The Manufacturer must calibrate all meters twice at 0%, 50% and 100% of flow for a total of 6 flow point calibrations. The dual flow calibration technique will confirm the results of the first flow test and ensure that the meter will exhibit a typical installed accuracy of $\pm 0.2\%$ or better of actual flow rate.
- C. The meter must be commissioned by an authorized representative of the manufacturer. The configuration of the meter must be programmed to fit the process and piping application of this project. The flow meter must have minimum of 3-year warranty from date of shipment.

1.05 MAINTENANCE AND SPARES

- A. Provide all parts, materials, fluids, etc. necessary for maintenance and calibration purposes. Deliver these supplies prior to substantial completion.

1.06 SYSTEM DESCRIPTION

- A. The electromagnetic flow meter is used for measuring the flow rate of wastewater at the facility. The meter must utilize the principle of magnetic induction to measure voltage induced that is proportional to the velocity of flowing wastewater through a magnetic flux.
- B. The standard accuracy of the meter output must not exceed $\pm 0.5\%$ of reading permitted. The meter must measure at this accuracy throughout 90% of the configured flow span. Where 'mount-anywhere' style meters are specified, meters must maintain the specified accuracy with not more than 1 diameter of straight upstream pipe, and zero diameters of downstream pipe.
- C. As described in this Section, the flow meters must have the operating features and include the appurtenant equipment listed within. The Manufacturer must supply any equipment necessary to set up the meter in working order.

1.07 SUBMITTALS

- A. Furnish complete Product Data, Shop Drawings, Test Reports, Operating Manuals, Record Drawings, Manufacturer's calibration certifications, Manufacturer's Field Reports.
- B. Product Data:
 - 1. Dimensional Drawings.
 - 2. Materials of Construction:
 - a. Metering Tube.
 - b. Liner.
 - c. Electrodes.
 - d. Coils.
 - e. Flanges.
 - f. Transmitter.
 - 3. Measurement accuracy.
 - 4. Range and range ability.
 - 5. Enclosure Rating.

6. Classification Rating.
7. Power:
 - a. Voltage.
 - b. Wattage.
8. Output signals.

PART 2 - PRODUCTS

2.01 MANUFACTURER

- A. 'Mount-Anywhere' Styles:
 1. Toshiba LF654 'Mount Anywhere' style.
 2. Endress + Hauser Promag 400W Series.
 3. Or approved equal meeting all requirements of this Section.
- B. Standard Installations:
 1. Siemens.
 2. Meters listed under 'mount-anywhere' style above.
 3. Other approved equal meeting all applicable requirements of this Section.

2.02 MANUFACTURED UNITS

- A. The electromagnetic flow meter must utilize the principle of magnetic induction ($E=B \cdot V \cdot D$) to measure voltage induced that is proportional to the velocity of flowing wastewater through a magnetic flux.
- B. The magnetic flow meter must consist of a flanged metering tube and a transmitter which may be mounted integrally or remotely with interconnecting cables up to 100 feet in length. Contractor must coordinate the final location of the meter with all mechanical piping due to space constraints and upstream straight pipe requirements of the meter. Coordinate with factory for compatible flange types and pipe fittings. If required straight approach pipe requirements cannot be met, contact the Engineer immediately.
- C. The meter must have an electrode quantity and configuration suitable to maintain an accuracy of $\pm 0.5\%$ of flow rate or better when mounted with minimum 5 diameters of straight pipe upstream, and 2 diameters of straight pipe downstream.
- D. Where 'mount-anywhere' style meters are specified, meters must have an electrode quantity and configuration to maintain an accuracy of $\pm 0.5\%$ with not more than 1 diameter of straight pipe between the upstream flange of the meter and adjacent elbows or fittings. **Meters requiring more than 1 upstream diameter of straight approach pipe are not acceptable where 'mount-anywhere' style meters are specified.** These meters must have no downstream piping requirements for maintaining the required accuracy specification.
- E. The flow meter must consist of a stainless steel tube with carbon steel flanges. Liner and 316L stainless steel electrodes must be chosen to support wastewater applications. An aluminum housing must enclose the coil assemblies and internal wiring and the full exterior of the meter must be painted with high quality epoxy paint.

- F. The tube must be lined with Polyurethane Rubber and must have ISO standard carbon steel flange. Unless noted otherwise furnish instrument flanges meeting ANSI/ASME B16.1 Class 150 for 24" and smaller.
- G. All sensing tubes (regardless of size) must be stamped with the original flow lab calibration factor to allow "dry configuration" and interchangeability between all flow converters and sensing tubes to original accuracy.
- H. The meter must be rated for NEMA 4X watertight.
- I. All components must have a minimum watertightness rating of IP67.
- J. Contractor must supply and install power and signal wiring per manufacturer's specifications between flow tube and remote meter controller.
- K. Provide sealing compound for meter terminal head and seal AFTER completion of all testing.
- L. Ground the flow tube in accordance with manufacturer's instructions.
- M. The transmitter must provide a specified network connection to the Owner's SCADA system and be capable of remote mounting.
- N. The meter must be capable of bi-directional flow without requiring any re-zeroing.
- O. Power supply to the meter must be 24 VDC.
- P. Cable termination on the spool must be factory potted to elevate junction to an IP68 level of protection of the terminations.
- Q. Transmitter:
 - 1. Transmitter housing must be powder coated cast aluminum with NEMA 4X rating.
 - 2. Transmitter must have a Touch pad that can support the onsite configuration of the flow meter without opening the electrical enclosure.
 - 3. Transmitter must have a 4-line x 16-character backlit LCD display used for configuration as well as for simultaneous display of process variable flow rate with an additional totalized value. Flow units must be user-selectable engineering Standard Imperial fluid velocity units, and option to customize to nonstandard units. Fault and alarm messages must also be visible within the user display.
 - 4. The flow meter must support a totalization feature.
 - 5. Meter must be supplied with surge protection in the power supply and the signal output circuit.
 - 6. Electronic circuit boards must be coated for protection from moisture and provide resistance from vibration and internal control temperature drift compensation.
 - 7. The meter must have the capability of being programmed remotely using HART and Fieldbus protocol.
 - 8. Upon any power failure, the unit must retain all setup parameters and accumulated measurements internally in non-volatile memory. All units must be protected against voltage spikes from the power source with internal transient protection. Power consumption must be no more than 15W including sensor.

9. The transmitter must output HART 4-20 mA DC signal directly proportional to flow rate and capable of 2 digital outputs for external applications. The analog output must have an adjustable response time from 0.06 to 100 seconds.

2.03 NOISE SUPPRESSION

- A. The meter must incorporate separate noise suppression and filtering circuits specially designed for slurry applications. Auto zeroing, averaging, or dampening type algorithms in lieu of noise filtering circuitry are not acceptable.
 1. A built-in rate limit function must be available to further eliminate extraneous output dynamics.
 2. User selectable or automatic switching excitation frequencies to further reduce noise.
 3. Required AC frequency excitation of 50 to 60 Hz, DC frequency excitation of 3 – 8 Hz or proprietary superimposed Dual frequency excitation 6 - 75Hz to further compensate accuracy from zero stability.

2.04 APPROVALS/CERTIFICATIONS

- A. The meter must be certified by NSF on NSF/ANSI Standard 61.
- B. The unit must have an ambient temperature rating of at least -20°C to 60°C for remote flow tube with Polyurethane rubber liner and remote/combined converter.
- C. Both the sensing tube and the converter must be IP67 rated for installation inside a dry and clean environment; otherwise, IP68 rated for installation in a wet and potential immersion location.

2.05 ACCESSORIES

- A. Stainless steel equipment tag labeled to match the Contract documents.
- B. Provide and install grounding rings, as per manufacture's recommendations.
- C. Provide factory potted unit or sealing compound for flow tube spool termination head.
- D. Provide a standard hand-held HART communicator with the current device driver.
- E. Provide galvanic isolation gaskets, nylon/Teflon flange bolt insulation bushing and nylon washers for the instrument when installed in cathodically-protected pipelines.

2.06 SOURCE QUALITY CONTROL

- A. Magnetic flow meters must be factory calibrated on an approved test stand with certified accuracy traceable to NIST, compliant with the ISO 17025 standard, and third-party accreditation by a national verification agency such as A2LA.
- B. A real-time computer-generated printout of the actual calibration data points indicate apparent and actual flows. The flow calibration data points must be confirmed by the manufacturer and must be confirmed with shipment of the meter to the Project Site.
- C. Provide complete documentation covering the traceability of all calibration instruments.
- D. Provide ISA data sheet ISA-TR20.00.01. Use the latest revision of form 20F2321. Complete the form with all known data and cross out the inapplicable fields. Incomplete data sheets submitted will result in a rejected submittal.

- E. The flow metering system must permit an optional traceable verification at the time of manufacturing. The verification must permit long term analysis of the transmitter linearity, repeatability, and sensor stability. The verification must be by a method which is NIST traceable.

2.07 SAFETY

- A. All electrical equipment must meet the requirements of ANSI/NFPA 70, NATIONAL ELECTRIC CODE, latest edition.
- C. The device must be suitable for use as non-incendive device when used with appropriate non-incendive associated equipment. Devices with intrinsically safe ratings will normally be acceptable with vendor’s approval.
- D. Electrical equipment housing must conform to NEMA 4x classification.
- E. Non-intrinsically safe electrical equipment must be approved by a Nationally Recognized Testing Laboratory (NRTL) such as FM, UL, ETL, CSA, etc.) for the specified electrical area classification.
- F. Electrical equipment specified as intrinsically safe must qualify as “simple apparatus” or NRTL approved intrinsically safe equipment per ANSI/ISA-RP12.6 “Installation of Intrinsically Safe Systems for Hazardous (Classified) Locations”, latest edition.

2.08 SPARE PARTS

- A. For each flow meter installation, provide one (1) substitute pipe spool which may be installed in place of the sensor tube if the tube ever needs to be removed. The substitute spool must be of the correct length to install and close the process piping with the sensor tube, grounding rings, and associated gaskets removed. Site specific spool requirements, if applicable, are shown in the Drawings.
- B. Substitute pipe must match the diameter, wall thickness, end type, bolt pattern, lining, and protective coatings of the adjacent process pipe. Field verify final installed length of the flow meter and appurtenances prior to fabricating the substitute spool.
- C. Provide 1 set pipe flange gaskets to match pipe spool.

2.09 FLOW METER EQUIPMENT SCHEDULE

A.

Site	Equipment Tag ID	Meter Diameter	Ends Style	Transmitter Mounting	Style*	Quantity

*Where ‘Standard’ style is listed, the meter is not required to comply with the accuracy requirements for ‘mount-anywhere’ conditions.

PART 3 - EXECUTION

3.01 EXAMINATION

- A. Examine the Drawings, the process fluids, pressures, and temperatures and furnish the instrument that is compatible with installed process condition.
- B. Examine the installation location for the instrument and verify that the instrument will work properly when installed. **Notify the Engineer immediately if the manufacturer's required mounting conditions cannot be met.**

3.02 INSTALLATION

- A. As shown on installation details and mechanical Drawings.
- B. As recommended by the manufacturer's installation and operation manual.
- C. Orient cable connections for sensor and transmitter downward to minimize opportunity for water ingress where possible.
- D. Where connections cannot be oriented downward, use drip loops in connected cables.
- E. Use silicone sealant on all threaded cable/conduit connections.
- F. Specific attention must be given to the following technical requirements:
 - 1. Verify grounding rings have been installed per the Manufacturer's recommendations.
 - a. Two (2) grounding rings installed with meter flanges where the meter is installed on non-metallic or lined pipelines.
 - b. One (1) grounding ring installed to upstream meter flange where the meter is installed on metallic pipeline.
 - 2. Install isolation gaskets where meters are used on cathodically-protected pipelines per factory's recommendations and design details.
 - 3. Fasten all screws and cable pots per Manufacturer's instructions.

3.03 FIELD QUALITY CONTROL

- A. Demonstrate the performance of the instrument to the Engineer before commissioning.
- B. The Engineer will witness the instrument calibration verification in the field.
- C. The instrument must be tested before commissioning and the design Engineer will witness the response in the PLC control system and associated registers.
- D. Manufacturer's Field Services:
 - 1. Manufacturers' representative must verify installation of all installed flow tubes and transmitters.
 - 2. Notify the Engineer in writing of any problems or discrepancies and proposed solutions.

3.04 ADJUSTING

- A. Verify factory calibration of all instruments in accordance with the Manufacturer's instructions.

3.05 PROTECTION

- A. All instruments must be fully protected after installation and before commissioning. Replace any instruments damaged before commissioning.
 - 1. The Engineer will be the sole party responsible for determining the corrective measures.

3.06 SPARE PARTS

- A. Deliver substitute pipe spool and gaskets to the project site and store in a location directed by the Owner. The ends of the spool must be protected for storage with caps or padding sufficient to prevent dings, dents, scratches, or similar damage from handling.

3.07 TRAINING

- A. Provide on-site training in accordance with manufacturer's recommendations and **Section 01 75 00 – Commissioning and Site Acceptance** and **Section 26 05 00 – Electrical: Basic Requirements**.
 - 1. Equipment performance specifications.
 - 2. Equipment operation, maintenance, and troubleshooting.
 - 3. Transmitter programming and configuration.

End of Section 40 91 16

SPECIFICATION SECTION 40 91 23

STAFF GAGE

PART 1 – GENERAL

1.01 SUMMARY

B. Section Includes:

1. Staff gauges for visual determination of wet well level.

1.02 DELIVERY, STORAGE, AND HANDLING

A. Protect gauges from impact, bending, and UV exposure during travel and storage.

1.03 SUBMITTALS

A. Furnish manufacturer's catalog cuts showing gauge materials, text font, size, layout, and recommended mounting method.

PART 2 – PRODUCTS

2.01 PRODUCT REQUIREMENTS

- A. Gauge material must be fiberglass reinforced polyester laminate with type set or computer-generated lines and numbers printed on a resin compatible material and laminated into the gauge. Surface mounted or painted markings are not acceptable. The face must be a flat molded surface.
- B. Gauge must be minimum 4-inches wide. Numbers must not be less than 1-inch wide. All markings and minor lines must be readily discernable from 10 feet away.
- C. Gauge must extend the entire depth of the wet well, from floor to ceiling. If the indicated location on the Drawings is above a channeled portion of the wet well, the gauge may terminate at the top of channeling, subject to requirements of **Paragraph 3.01.B** of this Section.
- D. Numbers, lines, and lettering must be in resin compatible, UV stabilized black ink. Background must be white.
- E. Gauge must display markings of depth above the lowest point of the wet well in increments of 0.1 feet.
- F. Gauge anchors must be epoxy anchored stainless steel bolts. Anchor hole spacing must be as recommended by the manufacturer, but in no case less than 2-feet on center.
- G. Acceptable products:
1. TFXW style Large Staff Gauge by Oregon Rule Co.
 2. Or approved equal.

PART 3 – EXECUTION

3.01 INSTALLATION

- C. Install gauge at the location shown in the Drawings. Verify location with the Engineer prior to installation.
- D. Gauge must be installed in a true vertical orientation and verified plumb before final mounting.
- E. Gauge must be set with the zero mark at the lowest level of the wet well sump such that the gauge reads the true depth of water in the well. The bottom of the gauge may be removed as needed if channeling in the wet well obstructs the gauge at the designated installation location. Seal any cut edges with manufacturer's approved epoxy resin or equivalent.

End of Section 40 91 23

SPECIFICATION SECTION 43 21 13

CONSTANT SPEED VERTICAL CENTRIFUGAL NON-CLOG PUMPS

PART 1 - GENERAL

17.02 SUMMARY

- A. Section Includes:
1. Provision and installation of constant-speed vertical (dry-pit) non-clog centrifugal sewage pumps and associated motors.
- B. Related Sections include but are not necessarily limited to:
1. Division 00 - Procurement and Contracting Requirements
 2. Division 01 - General Requirements
 3. Section 01 75 00 – Commissioning and Site Acceptance
 4. Section 40 05 02 – Equipment Mounting
 5. Section 40 05 03 – Machine Alignment

17.03 QUALITY ASSURANCE

- A. Referenced Standards:
1. American Bearing Manufacturers Association (ABMA).
 2. ASTM International (ASTM):
 - a. A48, Standard Specification for Gray Iron Castings.
 3. Hydraulic Institute (HI):
 - a. Standards for Centrifugal, Rotary and Reciprocating Pumps.
 4. Underwriters Laboratories, Inc. (UL):
 5. NEMA MG1
 6. Seattle Public Utilities Pump Station Design Standards and Guidelines.

17.04 SYSTEM DESCRIPTION AND REQUIREMENTS

- A. Furnish, install, adjust, test, and start vertical (dry-pit) centrifugal sewage pumps as specified below.
- B. It is the intent of these Specifications to obtain complete and operable equipment. All items and accessories appearing in the manufacturer's literature as standard, as modified herein, must be included. Since it is not possible to name every single component, all accessories necessary to accomplish the intent of these Specifications must be included as if they were specifically mentioned herein.
- C. All equipment and accessories must be of the highest quality available in the industry, and assembly and installation must show the highest quality of workmanship available in the respective trades.

- D. All equipment furnished must be new, unused, the products of manufacturers having a minimum of 20 years of experience in manufacturing, marketing and servicing units similar to those offered.

17.05 SUBMITTALS

- A. Procedures: See **Section 01 33 10 - Submittals** for requirements for the mechanics and administration of the submittal process.
- B. A copy of this specification section, with addendum updates included, and all referenced and applicable sections, with addendum updates included, with each paragraph check-marked to indicate specification compliance or marked to indicate requested deviations from specification requirements. Check marks (✓) denote full compliance with a paragraph as a whole. If deviations from the specifications are indicated, and therefore requested by the Contractor, underline each deviation and denote by a number in the margin to the right of the identified paragraph, referenced to a detailed written explanation of the reasons for requesting the deviation. The Engineer is the final authority for determining acceptability of requested deviations. The remaining portions of the paragraph not underlined will signify compliance on the part of the Contractor with the specifications. Failure to include a copy of the marked-up specification sections, along with justification(s) for any requested deviations to the specification requirements, with the submittal is sufficient cause for rejection of the entire submittal with no further consideration. Technical acceptance of a requested deviation does not constitute an approval of added costs.
- C. Certificate of Unit Responsibility attesting that the Contractor has assigned, and that the manufacturer accepts, unit responsibility in accordance with the requirements of this section and **Paragraph 1.04.B of Section 40 05 01 - General Requirements for Equipment**. No other submittal material will be reviewed until the certificate has been received and found to be in conformance with these requirements. For the purposes of this specification, Unit Responsibility applies to vertical centrifugal sewage pumps, mounting base with suction elbow, bearing frame, and electric motor.
- D. Shop Drawings: Engineering drawings showing the precise dimensions and weights of the actual components (pump, driver, motor, etc) and assemblies to be delivered to the job site. Drawings must include manufacturing and finishing tolerances, coating systems, mounting/base dimensions, mechanical seal details, shaft dimensions, pump suction and discharge sizes, rigging/hoisting points, any other dimensions relevant to the pump's interaction with the piping system, and any special handling instructions.
- E. Pump performance curves showing typical pump engineering data, including, but not limited to: proposed impeller trim, flow, head, efficiency, power requirements, minimum continuous stable flow, acceptable and preferred operating areas, best efficiency point, net positive suction head requirements, proposed and available impeller trims, and shutoff head. The Engineer may request other information specific to the proposed installation.
- F. Spare parts lists: A list of all parts required to overhaul each pump and motor.
- G. Motor cut sheets, product literatures, dimensioned drawings, and performance information demonstrating that the submitted motors meet the requirements of this specifications.
- H. Motor data summary sheet, listing: normal horsepower; NEMA design; frame size; enclosure type; winding insulation class and treatment; rated ambient temperature; service factor; voltage; phase; and frequency rating; full load current at rated horsepower

for application voltages; starting code letter, or locked rotor kVA or current; special winding configuration as such part-winding star-delta (include winding diagram); rated full load speed; power factor at full load; noise certification and data sheets; bearing types and catalog numbers.

- I. Motor performance characteristics:
 - 1. Guaranteed minimum efficiency at rated load at rated voltage.
 - 2. Guaranteed minimum power factor at rated load at rated voltage.
 - 3. Expected efficiency at 1/2, 3/4, and full load at rated voltage.
 - 4. Expected power factor at 1/2, 3/4, and full load at rated voltage.
 - 5. Full load current at 110 percent voltage.
 - 6. Starting current at rated voltage.
 - 7. Time in seconds motor can be subjected to locked rotor current at rated voltage without damage to motor with: (1) motor initially at the rated ambient temperature, and (2) motor initially at the rated temperature rise.
- J. Pump bearing life and shaft stress loading calculations demonstrating conformance with this specification. Calculations must be prepared and sealed by a professional engineer registered in the State of Washington.
- K. Seismic anchorage calculations. Calculations must be prepared and sealed by a professional engineer registered in the State of Washington.
- L. Calculated loads (forces and moments) on the pump nozzles when operating at the specified design point(s).
- M. Factory pump and motor test reports, including motor performance curves. See **Part 3** of this Section.
- N. Operation and Maintenance Manuals:

Furnish 2 bound and indexed hard-copy and 1 electronic copy, in PDF format, Operations and Maintenance Manuals, prepared by the pump manufacturer, properly organized for quick reference and must include the following minimum information:

 - Part 1 - Operating instructions
 - Part 18 - Maintenance instructions
 - Part 19 - Parts lists
 - Part 20 - Dimensional drawings
 - Part 21 - Assembly drawings
 - Part 22 - Installation instructions
 - Part 23 - Equipment performance and factory test data
- N. Startup testing report showing results of all startup testing including, including calculated pump curve, performance data, vibration records, and alignment records.

PART 2 - PRODUCTS

2.01 GENERAL

- A. The pumping units as described herein must include all parts and accessories listed below or as necessary for proper installation of complete units. These must include:
1. Pump
 2. Mounting base with suction elbow
 3. Frame
 4. Electric Motor
 5. All parts necessary to connect all components of the pumping units together.
 6. Spare parts, as required by this section.

2.02 PUMPS

- A. The pumps must be constant-speed, vertical coupled, single stage, single bottom suction, centrifugal, dry pit, non-clog, overhung impeller, flexible coupled type, designed specifically for pumping raw sewage.
- B. The pumps must be driven by electric motors. The units must be suitable for automatic control according to level in the wet well. The pumps will start and stop against closed check valves.
- C. Pumping units must be capable of operating continuously at any flow and head within the proposed operating range without damage to any component and without vibration levels exceeding those specified herein below.
- D. Vibration in the field must not exceed 0.2 inch/second velocity as measured by the Standards of the Hydraulic Institute. Pump structure must be designed to have a first natural frequency of at least twice the shaft rotative speed. Natural frequency or resonance must not affect the operation of the pump at any point within the range specified.

2.03 PUMP COMPONENTS

- A. Casing:
1. The pump casing (volute) must be of back pullout design allowing for removal of the rotating element without disturbing piping connections. The casing must be constructed of fine grain Cast Iron of ASTM A48 Class 40. All casing sections must have heavy wall thickness to provide long life under abrasive and corrosive operating conditions. All mating surfaces must have register fits to ensure proper alignment.
 2. Piping connections must be ANSI/ASME 125# flat-face drilled flanges on discharge and suction. Flange face surface finish must be a minimum of 250 micro-inch finish. Casing must be furnished with drilled, tapped, and plugged drain ports.
 3. Discharge nozzle must have a tapping boss located on the top side adjacent to the discharge flange. This boss must be drilled and tapped and, upon installation of the pump, fitted with a 3/4" brass ball valve, elbow, and hose routed to the station sump.
- B. Impeller: **[Designer to specify required impeller material in coordination with SPU based on anticipated operating conditions. Cast Iron is typically used for normal conditions and high chrome ductile iron is typically used for severe duty**

conditions].

The impeller must be of heavy section ductile iron per ASTM A536 100-70-03 with hardness of 230-300 BHN, suitable for abrasive (sand), rag, and solids handling duty. Impellers must be capable of passing up to a 3.0" soft solid. Impellers must have back vanes to reduce axial thrust and lower the pressure on mechanical seals. Internal vane edges must be well rounded to present smooth flow. Impeller must have a straight non-tapered bore, be statically and dynamically balanced, keyed to the shaft and further secured with a stainless steel washer and a stainless steel impeller lockscrew. The impeller must be fixed at location with no expected or required adjustment.

- C. Wear Rings: Replaceable suction wear rings must be press fit into the casing and heat-shrunk onto the Impeller. The double wear ring system must be of the peripheral design requiring no axial adjustment. The wear rings must be constructed of ASTM A276 Type 420 Stainless Steel, Heat Treated to 400-500 BHN, with a minimum of 100 BHN difference to prevent galling. Wear rings that require an external axial adjustment are not acceptable.
- D. Cutting System: **[Designer to specify cutting system where required for ragging mitigation, see SPU DSG Chapter 11 for guidance].**
The pump must incorporate a cutting system generally consisting of rotating blades on the impeller acting against a stationary cutter plate on the suction intake. All components of the cutting system must be adjustable, removable, and replaceable. Cutting surfaces must be constructed of ASTM A276 Type 420 Stainless Steel, Heat Treated.
- E. Mechanical Sealing System: A dished style backplate with deflector vanes constructed of ASTM A48 Class 30 Grey Iron must be provided, including a single mechanical seal. The design must allow for continuous operation without the need for external flush water or venting. Double seals or cartridge seals requiring a water flush system are not acceptable. The seal must have a 316 stainless steel rotating spring. The seal faces will be tungsten carbide vs. silicon carbide with Buna-N "O" ring. Seal must be a single, outside elastomer-bellows type mechanical seal such as John Crane Type 1 or approved equal. The pump manufacturer must have a minimum of 20 years of experience manufacturing pumps with this type of seal system. Mechanical Sealing System must be Cycloseal by Cornell Pump Co. or approved equal flushless sealing system with these characteristics.
- F. Frame: The end suction centrifugal pump must be pedestal frame style with ASTM A48 Class 30 fine grain Grey Iron bearing frame. The bearing frame must be equipped with antifriction style bearings. The bearings must be either ball or roller style properly sized to accommodate all thrusts, both mechanical and hydraulic imposed upon them. The frame must be designed for captured bearing positioning and must not require any field axial adjustment. The bearings must have a minimum calculated L-10 bearing life rating of 50,000 hours with pump operating at 25% of BEP capacity with the supplied impeller diameter. See **Article 1.04** of this Section for submittal requirements. Bearing lubrication must be grease with proper provisions to facilitate easy lubrication in the field. Pumps that are close-coupled or rely on the motor bearings to handle the hydraulic loading are not acceptable.
- G. Shaft: The pump shaft must be of high strength carbon steel equal to MOD SAE1144 "Stress-Proof Steel". The pump shaft must be accurately machined and polished and of sufficient size to transmit the maximum horsepower to be encountered when the pump is operating with a maximum diameter impeller and at the maximum rated motor operating speed.

- H. Shaft Sleeve: The shaft must be protected by a renewable shaft sleeve, which extends through the stuffing box and under the gland. The sleeve must be grooved on the inside for an o-ring to prevent leakage along the shaft and must be positively locked to prevent rotation. The sleeve O.D. must be a minimum of 0.375 inches over the shaft diameter and constructed of 420 Stainless Steel, Heat Treated to 400-500 BHN. The shaft sleeve must be positively secured to the shaft by a key to prevent slip between the sleeve and the shaft. Minimum shaft sleeve size at the seal faces must be 3.00".
- I. Motor Bracket: The pump must be fitted with an ASTM A48, Class 30 Cast Iron or ASTM A36 Fabricated Steel motor support bracket. The bracket must have a register fit for locating the motor flange. The bracket must have ample space to install, adjust and replace the coupling. Motor mounting face must be machined flat and true.
- J. Drive coupling: The pump and motor must be connected by a flexible coupling that will allow for slight misalignment and tolerance differences between the motor and the support bracket. Coupling must be capable of transmitting the full horsepower of the connected motor.
- K. Guards: Furnish guards to cover the pump/motor interface and any exposed portions of the drive shaft. Guards must be made of stainless steel expanded metal mesh and securely fasten to pump body with hand-removable vibration-resistant hardware (nylock wing nut or equivalent).
- L. Base Plate and Elbow: The base elbow must be constructed of ASTM A48, Class 30 Cast Iron, heavy-section construction with a bolted and contoured clean out port. The fabricated Steel base must be of sufficient strength to support the entire weight of assembled pump and motor and of sufficient height so that no part of the actual elbow will touch the floor. The base must have support gussets and base plate to raise the 1st natural frequency of the pump motor unit to a minimum of 2X the operating speed. Flanges must be 125# ANSI/ASME standard. Base elbow suction and discharge size must be as noted in **Article 2.07** of this Section.
- M. Coatings: Provide coating system as recommended by the manufacturer. At a minimum, the coating system must be a 3-coat, epoxy based, abrasion resistant system which is specifically labeled for atmospheric exposure to wastewater environments. Furnish 1 quart of finish coat paint.
 - 1. All gears, bearing surfaces and other surfaces obviously not to be painted must be given a heavy coat of grease or other suitable rust resistant coating, unless otherwise specified herein. This coating must be maintained, as required, to prevent corrosion during periods of storage and installation.
- N. Data Plates: Each pump must be furnished with a stainless steel nameplate fastened with screws. The plate must be stamped with the pump manufacturer, serial number, design nominal speed, horsepower, installed and maximum impeller diameter, design total dynamic head in feet, and design flow in gallons per minute. Pump equipment tag and asset number (provided by the Owner) must be provided on a separate stainless steel tag on each pump.
- O. Nozzle Vent: Tap and Install 3/4" brass ball valve and fittings in the discharge nozzle top side tapping boss. Furnish with 3/4" clear polyethylene hose of sufficient length to reach dry well sump.

2.04 MANUFACTURER

- A. Pump manufacturer or their authorized distributors must have 24/7/365 service capabilities and maintain a full-service shop with 25 miles of the Project Site.
- B. Pumps must be by:
 - 1. Cornell Pump Co.
 - 2. or approved equal meeting all requirements of this Section.

2.05 PUMP MOTORS

- A. General:
 - 1. Motors and auxiliaries must comply with the latest applicable IEEE, ANSI and NEMA Standards, which are hereby made a part of these Specifications.
 - 2. It is not the intent to specify details of design and construction. The motor must be constructed and equipped with accessories in accordance with the manufacturer's standard practices where they do not conflict with this Specification.
- B. Motor Design:
 - 1. The motors must be of the squirrel cage induction type, 1.15 Service Factor, IEEE 841XL TEFC P-Base vertical solid shaft suitable for wastewater pump applications and continuous operation at full load rating not to exceed 40° Centigrade ambient temperature. The motors must not be overloaded beyond its full load rating by any operating condition on the pump characteristic curve and suitable for operating with reduced voltage soft start controllers between 100% and 50% of full speed, across-the-line start and/or solid-state drive applications. Inrush current must not exceed 5.6 KVA per rated horsepower, NEC Design code F (5.0-5.6). Motors must be designed for frequent repetitive starting, with a cycle time of 10 minutes.
 - 2. The motors must be capable of withstanding the effect of automatic reacceleration following voltage dip or momentary interruption without damage and operate successfully under running conditions at rated load with variation in the voltage or the frequency not exceeding the following conditions:
 - a. +/-10% rated voltage at rated constant volts/hertz ratio, except for specific torque boost starting applications
 - b. +/-5% rated frequency at rated constant volts/hertz ratio.
 - c. successful operation under the voltage unbalance at the motor terminals that does not exceed 1%.
 - 3. The motors must be designed to withstand a 5% overspeed in either direction of rotation. Motor torques must conform with NEMA MGI-20.41.
 - 4. Motors must be designed to produce a maximum noise level of 95 dB at a distance of one meter from their surface. Insulation system must be rated type "F" or better, suitable for a maximum temperature of 155 degrees C.
 - 5. The motor must be dynamically balanced and fan cooled. The use of solder or similar deposits is not acceptable. Any parent metal removed to achieve dynamic or static balance must be removed in a manner which will maintain the structural integrity of the rotor.

6. The motors must be of the "premium efficiency type" NEMA Design B with a guaranteed minimum normal full-load efficiency per the current WAC 51-11C-40508, Table C405.8(1). Motors must have a maximum temperature rise at continuous full load of 80 degrees by resistance measurement. Efficiency and temperature rise must be stamped in the nameplate. Submitted motor efficiency must be demonstrated with certified tests in accordance with the Standard 112-a of the IEEE.
- C. Bearings:
1. Bearings must be anti-friction type, ball bearing, double shielded (code ZZ) and lubricated of adequate capacity to assure a minimum L-10 life of 50,000 hours. Anti-friction bearings must be made from vacuum degassed steel.
 2. Bearing and corresponding lubricant must be capable of assuring the minimum service as stated above. The bearings must have readily accessible grease inlet and outlet fittings in the bearing housing to allow regreasing from the exterior. Oil lubricated bearings are not acceptable.
 3. Motor housing must have zerk fittings for greasing of both upper and lower bearings.
 4. Bearings must be protected from shaft current produce by common mode voltages and other electromagnetic interference.
- D. Motor Construction:
1. Frame must be rated for severe duty applications and fabricated carbon steel, and end bells must be made of heavy duty, impact resistant cast iron. Motor power terminal junction box for conduits and wire connections as specified must be over-sized meeting volumes provided in IEEE 841 - 2021 with standard threads. Metric threads will not be accepted. Terminal boxes must be diagonally split, rotatable in 90° increments, and attached to the motors frame with high strength zinc plated and chromated steel bolts and cap screws. Grounding lug/terminal and ungrounded terminals inside terminal boxes must allow use of 75°C rated conductors.
 2. The motor mechanical design and coil bracing must be suitable for full voltage starting and also 5 cycle bus transfer as a precaution against possible high-speed reclosing. All winding and rotor bars must be copper. End coil bracing must be in place before VPI process. Insulation system must meet NEMA MG1 Part 31.4.4.2 and rated type "F" or better, suitable for maximum average temperature of 155 degrees C or higher. Individual turns in the starter coils must be insulated with Class "H" enamel covered with two layers of polyester and glass yarn.
 3. Motor must be sized such that it will deliver full rated power and service factor at its rated temperature rise if the motor is later rewound, by a motor shop approved by the motor manufacturer, using conventional insulation.
 4. The enclosure must provide access to the interior parts of the motor for inspection or minor cleaning without a major disassembly of the motor. End-shields and bearing housings must be provided to permit bearing and winding inspection without the need for realignment. Motor vent openings must have removable stainless steel guard screens and inlet air filters with stainless steel media.

5. Lifting lugs must be furnished, designed in accordance with NEMA MG 2-2.02.
6. All hardware must be made of 316 stainless steel.
7. Exposed surfaces must be protected with at least two coats of epoxy type paint after the surface has been cleaned and primed according to the instructions of the epoxy paint manufacturer. Motor vent openings must have stainless steel guard screens and inlet air filters with stainless steel or aluminum media. Finish color must be light gray conforming to ANSI 61.

E. Stator:

1. The complete stator must be a sealed system which receives at least two complete vacuum pressure impregnation process cycles of 100% solids epoxy resin to prevent corrosion. Windings must be provided with a polyurethane dispersion to inhibit insulation abrasion by sand, salt, fly ash or other abrasive materials entrained in the cooling air.
2. Stator and rotor core pieces must be machine stamped from low loss non-aging silicon steel. Laminations must be insulated by a layer of varnish or enamel.

F. Rotor Shaft:

1. Rotor shafts must be designed for maximum strength and rigidity and must be manufactured from carbon steel meeting SAE standard for 1045 steel.
2. For the rotor shaft, the critical speed must be a minimum of 20% above the rated motor speed.
3. Motors must be provided with a shaft grounding device (typical requirement for motors 30hp or larger)

G. Data Plates:

1. All data plates must be stainless steel suitable attached to the pump. Data plates must contain the manufacturer's name, pump size and type, serial number, speed, impeller diameter, capacity and head rating, efficiency, temperature rise and other pertinent data must be stamped in the nameplate.
2. A special data plate must be attached to the pump frame which must contain identification of frame and bearing numbers.

2.06 TOOLS AND SPARE PARTS:

A. Special Tools:

Furnish, together with the pumping units, 1 set of any special tools, other than common plant mechanic's tools, necessary to install, adjust, maintain or repair the pumping units or any of the components.

B. Spare Parts:

1. Furnish parts list with manufacturer's part numbers for all replaceable pump, driver, and motor components. Furnish separate recommended parts list for pump overhaul.
2. Furnish one (1) spare set of mechanical seals for each pump supplied.

2.07 ANCHOR BOLTS

- A. Anchor bolts must be constructed of Type 316 stainless steel
- B. Furnish anchor bolts of the type, size, and dimensions shown in the approved seismic anchorage calculations.

2.08 PUMP SCHEDULE

- A. Furnish pumping units in accordance with the tables below. The station normally operates with one pump, but will occasionally operate with two pumps running in parallel during high flow events. The Primary Duty Point represents the most common wet well level for operation.

Pump model and impeller trim must be selected such that the pump is capable of operating at the stated duty conditions while within the Preferred Operating Region of 70%-120% of the pump's Best Efficiency Point flow.

Pump Quantity		
	One Pump Running	Two Pumps Running in Parallel
Primary Duty Point (Static Head X.XX')	X GPM X TDH X NPSHA	X GPM, per pump X TDH X NPSHA
Nominal Speed, RPM		
Minimum Efficiency at Primary Duty Point, %		
Motor Horsepower, HP		
Discharge Size, in.		
Suction Size, in.		
Configuration	[Vertical Coupled, Horizontal Coupled, etc]	
Rotation Direction	[Clockwise, counterclockwise]	
Nozzle Configuration	[Centerline, tangential]	

2.09 WARRANTY

- A. Pumps must be warrantied for a period of 2 full years after date of commissioning.

PART 3 - EXECUTION

3.01 TESTING, GENERAL

- A. The tests of the pumping units are divided into four parts: Hydrostatic tests of pump component parts at the pump factory, tests of the motors at the motor factory, tests of

the assembled pumps at the factory, and final acceptance tests to be conducted after installation.

- B. Tests must be scheduled only after the factory has pre-tested the unit and submitted preliminary test data that has been deemed satisfactory by the Engineer of Record.
- C. Factory pump testing acceptance criteria must be per Hydraulic Institute Standard 14.6 Grade X
**[Designer to specify appropriate HI Grade for pump testing:
 Typically,
 8" and larger pumps – Grade 1U
 6" pumps – Grade 1E
 4" pumps – Grade 2B]**
- D. Test reports certified by a manufacturing company representative who is a Registered Professional Engineer in the State of Washington.

3.02 HYDROSTATIC TEST OF PUMP COMPONENTS

- A. Pump must be hydrostatically tested to 1.25 times the shutoff pressure at the listed operating speed for the largest impeller trim available for the pump, regardless of actual installed trim.

3.03 MOTOR TEST

- A. Routine factory certified tests must be given to each motor as required by NEMA and ANSI Standards. Tests must be performed in accordance with IEEE Standard No. 112A "Test Procedures for Polyphase Induction Motors and Generators".
 1. At minimum, report list of tests:

Description	Factory Test	Standards
Winding resistance cold	x	IEEE 112
Test with locked rotor	x	IEEE 112
Temperature rise	x	IEEE 112
Load test: Full load, 75% load, 50% load, no load	x	IEEE 112
High potential test	x	IEEE 112
Breakdown torque test	x	IEEE 112
Speed-Torque curve	x	IEEE 112
Insulation resistance test	x	IEEE 112

- B. In addition to the above, factory tests must include sound level and peak-to-peak amplitude of vibration. Pull-in and pull-out torque must be determined. Tests must be made according to standard NEMA procedures and certified copies of reports and speed-torque curves must be furnished to the Owner before pump delivery.
- C. The motor must be tested for vibration at no load and at rated voltage and frequency. The maximum allowable peak-to-peak amplitude of vibration on the bearing chambers must be 2.0 mils.

3.04 FACTORY PUMP TESTING

- A. The pump must be tested to develop the performance curves and for assurance of proper and vibration free operation.
 - 1. Data gathering must be in accordance with Hydraulic Institute Standards. Curves must be plotted using the data obtained at the tests. All curves must extend from shut-off to actual runout points. Curves must include: head vs. capacity, brake horse power, mechanical efficiency and wire to water efficiency. There should be a minimum of 5 test points spaced at approximately equal head, with one test point at the designated duty point for that pump.
 - 2. Vibration must be continuously monitored and recorded during all pump tests.

3.05 FIELD ACCEPTANCE TESTING

- A. Field tests and assistance must be provided by service technicians from the manufacturer or their authorized distributor (see **Article 2.04** of this Section), experienced in each kind of equipment installed, and for each specific function.
- B. For equipment start-up and acceptance tests, the factory representative must supervise the start-up and acceptance testing of each pumping unit, as described below. The pumping unit will be subjected to operational testing under a variety of conditions including low NPSHA and various discharge heads to verify the factory performance curve. Also included must be vibration measurement tests as described in other paragraphs of this subsection of the Specifications. The factory representative's service technicians must perform all final alignment and adjustments necessary for the best possible operation.
 - 1. Initial field testing may be performed with the station in recirculation mode. Final tests including the field-measured pump curve must be performed using the station's force main in the normal duty condition.
- C. At the end of each start-up and acceptance tests, including vibration measurements, the Engineer and the factory representative will jointly analyze the test data. If all evidence proves that the installation is correct, the factory representative must issue a certification which must be stamped by a Registered Professional Civil engineer licensed in the state of Washington. Upon acceptance of the Engineer of the statements in the certification, the unit will be considered accepted.

3.06 INSTALLATION

- A. All of the equipment specified under this section of the specifications must be installed in strict accordance with this Section, the instructions received from the manufacturers, and **Section 40 05 02 – Equipment Mounting and Section 40 05 03 – Machine Alignment**. Workmanship and miscellaneous materials must follow the best standards of quality recognized for the trades involved. Where there may be conflicts between the

Specifications and manufacturer's instructions, this must immediately be brought to the attention of the Engineer, who will issue orders resolving the conflict, and its opinion will be final and binding for all involved parties.

- B. Prior to Site Acceptance, deliver all required spare parts and paint to the Project Site.

End of Section 43 21 13

SPECIFICATION SECTION 43 21 14

CONSTANT SPEED VERTICAL CENTRIFUGAL CHOPPER PUMPS

PART 1 - GENERAL

23.02 SUMMARY

- A. Section Includes:
 - 1. Provision and installation of constant speed vertical (dry-pit) centrifugal chopper sewage pumps and associated motors. for use at Pump Station 118.
- B. Related Sections include but are not necessarily limited to:
 - 1. Division 00 - Procurement and Contracting Requirements
 - 2. Division 01 - General Requirements
 - 3. Section 01 75 00 – Commissioning and Site Acceptance
 - 4. Section 40 05 02 – Equipment Mounting
 - 5. Section 40 05 03 – Machine Alignment

23.03 QUALITY ASSURANCE

- A. Referenced Standards:
 - 1. American Bearing Manufacturers Association (ABMA).
 - 2. ASTM International (ASTM):
 - a. A48, Standard Specification for Gray Iron Castings.
 - 3. Hydraulic Institute (HI):
 - a. Standards for Centrifugal, Rotary and Reciprocating Pumps.
 - 4. Underwriters Laboratories, Inc. (UL):
 - 5. NEMA MG1
 - 6. Seattle Public Utilities Pump Station Design Standards and Guidelines.

23.04 SYSTEM DESCRIPTION AND REQUIREMENTS

- A. Furnish, install, adjust, test, and start vertical (dry-pit) centrifugal chopper sewage pumps as specified below.
- B. It is the intent of these Specifications to obtain complete and operable equipment. The Contractor must furnish all items and accessories shown in the manufacturer's literature as standard, as modified herein. Since it is not possible to name every single component, all accessories necessary to accomplish the intent of these Specifications must be included as if they were specifically mentioned herein.
- C. All equipment and accessories must be of the highest quality available in the industry, and assembly and installation must show the highest quality of workmanship available in the respective trades.

- D. All equipment furnished must be new, unused, the products of manufacturers having a minimum of 20 years of experience in manufacturing, marketing and servicing units similar to those offered.

23.05 SUBMITTALS

- A. Procedures: See **Section 01 33 10 - Submittals** for requirements for the mechanics and administration of the submittal process.
- B. A copy of this specification section, with addendum updates included, and all referenced and applicable sections, with addendum updates included, with each paragraph check-marked to indicate specification compliance or marked to indicate requested deviations from specification requirements. Check marks (✓) denote full compliance with a paragraph as a whole. If deviations from the specifications are indicated, and therefore requested by the Contractor, underline each deviation and denote by a number in the margin to the right of the identified paragraph, referenced to a detailed written explanation of the reasons for requesting the deviation. The Engineer is the final authority for determining acceptability of requested deviations. The remaining portions of the paragraph not underlined will signify compliance on the part of the Contractor with the specifications. Failure to include a copy of the marked-up specification sections, along with justification(s) for any requested deviations to the specification requirements, with the submittal is sufficient cause for rejection of the entire submittal with no further consideration. Technical acceptance of a requested deviation does not constitute an approval of added costs.
- C. Certificate of Unit Responsibility attesting that the Contractor has assigned, and that the manufacturer accepts, unit responsibility in accordance with the requirements of this section and **Paragraph 1.04.B of Section 40 05 01 - General Requirements for Equipment**. No other submittal material will be reviewed until the certificate has been received and found to be in conformance with these requirements. For the purposes of this specification, Unit Responsibility applies to vertical centrifugal sewage pumps, mounting base with suction elbow, frame, and electric motor.
- D. Shop Drawings: Engineering drawings showing the precise dimensions and weights of the actual components (pump, driver, motor, etc) and assemblies to be delivered to the job site. Drawings must include manufacturing and finishing tolerances, coating systems, mounting/base dimensions, mechanical seal details, shaft dimensions, pump suction and discharge sizes, rigging/hoisting points, any other dimensions relevant to the pump's interaction with the piping system, and any special handling instructions.
- E. Pump performance curves showing typical pump engineering data, including, but not limited to: proposed impeller trim, flow, head, efficiency, power requirements, minimum continuous stable flow, acceptable and preferred operating areas, best efficiency point, net positive suction head requirements, proposed and available impeller trims, and shutoff head. The Engineer may request other information specific to the proposed installation.
- F. Spare parts lists: A list of all parts required to overhaul each pump and motor.
- G. Motor cut sheets, product literatures, dimensioned drawings, and performance information demonstrating that the submitted motors meet the requirements of this specifications.
- H. Motor data summary sheet, listing: normal horsepower; NEMA design; frame size; enclosure type; winding insulation class and treatment; rated ambient temperature; service factor; voltage; phase; and frequency rating; full load current at rated horsepower

for application voltages; starting code letter, or locked rotor kVA or current; special winding configuration as such part-winding star-delta (include winding diagram); rated full load speed; power factor at full load; noise certification and data sheets; bearing types and catalog numbers.

- I. Motor performance characteristics:
 - 1. Guaranteed minimum efficiency at rated load at rated voltage.
 - 2. Guaranteed minimum power factor at rated load at rated voltage.
 - 3. Expected efficiency at 1/2, 3/4, and full load at rated voltage.
 - 4. Expected power factor at 1/2, 3/4, and full load at rated voltage.
 - 5. Full load current at 110 percent voltage.
 - 6. Starting current at rated voltage.
 - 7. Time in seconds motor can be subjected to locked rotor current at rated voltage without damage to motor with: (1) motor initially at the rated ambient temperature, and (2) motor initially at the rated temperature rise.
- J. Pump bearing life and shaft stress loading calculations demonstrating conformance with this specification. Calculations must be prepared and sealed by a professional engineer registered in the State of Washington.
- K. Seismic anchorage calculations. Calculations must be prepared and sealed by a professional engineer registered in the State of Washington.
- L. Calculated loads (forces and moments) on the pump nozzles when operating at the specified design point(s).
- M.
- N. Factory test reports. See **Part 3** of this Section.
- O. Operation and Maintenance Manuals:
 - 1. Furnish 1 electronic indexed Operations and Maintenance manual, prepared by the pump manufacturer, properly organized for quick reference and must include the following minimum information:

Part 1 - Operating instructions

Part 24 - Maintenance instructions

Part 25 - Parts lists

Part 26 - Dimensional drawings

Part 27 - Assembly drawings

Part 28 - Installation instructions

Part 29 - Equipment performance and factory test data

PART 2 - PRODUCTS

2.01 GENERAL

- A. The pumping units as described herein, must include all parts and accessories listed below or as necessary for proper installation of complete units. These must include:
 - 7. Pump.

8. Mounting base with suction elbow.
9. Frame.
10. Electric Motor.
11. All parts necessary to connect all components of the pumping units together, including bolts, gaskets, drive couplings, and the like.
12. Spare parts lists and operations manual.

2.02 PUMPS

- A. The pumps must be constant-speed, vertical coupled, single stage, single bottom suction, centrifugal, dry pit, overhung impeller, flexible coupled type. Pumps must be specifically designed to pump sewage with high concentrations of solids, heavy rags, grease balls, stringy materials, etc without plugging or clogging. Materials must be chopped and conditioned by the pump as an integral part of the pumping action.
- B. The pumps must be driven by electric motors. The units must be suitable for automatic control according to level in the wet well. The pumps must start and stop against closed check valves.
- C. Pumping units must be capable of operating continuously at any flow and head within the proposed operating range without damage to any component and without vibration levels exceeding those specified herein below.
- D. Vibration in the field must not exceed 0.2 inch/second velocity as measured by the Standards of the Hydraulic Institute. Pump structure must be designed to have a first natural frequency of at least twice the shaft rotative speed. Natural frequency or resonance must not affect the operation of the pump at any point within the range specified.

2.03 PUMP COMPONENTS

- A. Casing: The pump casing must be centerline discharge, of back pullout design allowing for removal of the rotating element without disturbing piping connections. The casing must be constructed of ductile iron. All casing sections must have heavy wall thickness to provide long life under abrasive and corrosive operating conditions. All mating surfaces must have register fits to ensure proper alignment. Piping connections must be ANSI 125# flat-face drilled flanges on discharge and suction. Flange face surface finish must be a minimum of 250 micro-inch finish. Casing must be furnished with drilled, tapped, and plugged drain ports. Casing must include a tapping boss on the top side of the discharge nozzle drilled and tapped for a 3/4" connection.
- B. Impeller: **[Designer to specify appropriate impeller material for the anticipated operating conditions in coordination with SPU and the manufacturer.]**
Impeller must be of the semi-open type with vanes specifically designed to reduce seal area pressure and must include sharpened leading edges to accomplish the required chopping action against a fixed cutter bar. Impeller must be cast alloy steel heat treated to minimum Rockwell C 60 hardness and dynamically balanced. Impeller must be keyed to the pump shaft at a fixed location without set screws or axial adjustment.
- C. Cutter Bar Plate: Recessed into the pump bowl, containing at least two shear bars extending diametrically across the intake opening to a clearance from the cutter nut tooth appropriate to prevent intake opening blockages and wrapping of debris at the shaft area. Cutter bars must be cast alloy steel heat treated to minimum Rockwell C 60 hardness.

- D. Cutter Nut: The cutter nut must secure the impeller to the pump shaft and include a raised rotating cutter tooth designed to cut stringy materials and prevent binding.
- E. Upper Cutter: Threaded into the back pull-out adapter plate behind the impeller, designed to cut against the impeller vanes and impeller hub, reducing and removing debris from the mechanical seal area. Upper cutter must be cast alloy steel heat treated to minimum Rockwell C 60. The upper cutter teeth must be placed as close as possible to the center of shaft rotation to reduce cutting torque. The ratio of upper cutter cutting diameter to shaft diameter in the upper cutting area must be 3.0 or less.
- F. Pump Shafting: Must be heat treated alloy steel.
- G. Bearings: The bearings must be either ball or roller style properly sized to accommodate all thrusts, both mechanical and hydraulic imposed upon them. The bearings must have a minimum calculated L-10 bearing life rating of 50,000 hours with the supplied impeller diameter. See **Article 1.04** of this Section for submittal requirements. Bearing lubrication must be grease with proper provisions to facilitate easy lubrication in the field. **Oil-lubricated bearings are not acceptable. Pumps that are close-coupled or rely on the motor bearings to handle the hydraulic loading will not be acceptable.**
- H. Bearing Housing: Constructed of ductile iron and machined with piloted bearing fits. Thrust bearings must be mounted in a manner that allows for external adjustment of impeller-cutter clearances. Bearing housing must include double lip seals at each end of the bearing housing. Provide grease injection points (i.e. 'zerk' fittings) as needed to ensure that each bearing can be flushed and greased without removal.
- I. Mechanical Sealing System: Must be designed specifically to not require external flushing. Seal must be located immediately behind the impeller hub to maximize flushing available from the impeller pumpout vanes. Seal must be a single, outside elastomer-bellows cartridge mechanical seal with tungsten carbide vs silicon carbide and Viton O-rings. Cartridge seal springs must be shielded from the fluids to be pumped. The cartridge must also include a 17-4PH, heat treated seal sleeve and stainless-steel seal housing. John Crane Type 1 or 2 or approved equal.
- J. Shaft: Heat treated alloy steel. The pump shaft must be accurately machined and polished and of sufficient size to transmit the maximum horsepower to be encountered when the pump is operating with a maximum diameter impeller and at the maximum rated motor operating speed.
- K. Motor Bracket: The pump must be fitted with a motor mounting bracket. The bracket must have a register fit for locating the motor flange. The bracket must have ample space to install, adjust and replace the coupling.
- L. Drive coupling: The pump and motor must be connected by a flexible coupling that will allow for slight misalignment and tolerance differences between the motor and the support bracket. Coupling must be capable of transmitting the full horsepower of the connected motor.
- M. Guards: Furnish guards to cover the pump/motor interface and any exposed portions of the drive shaft. Guards must be made of impact-resistant polycarbonate and must be readily installable and removable without tools.
- N. Base Elbow: The pump assembly must be mounted vertically on a 90 degree carbon steel elbow with a Class 125 inlet flange, cleanout port, 1/4" NPT suction pressure tap, drain connection, and pedestal base. The fabricated steel base must be of sufficient strength to support the entire weight of assembled pump and motor and of sufficient

height so that no part of the actual elbow will touch the floor. The base must have support gussets and base plate to raise the 1st natural frequency of the pump motor unit to a minimum of 2X the operating speed. Flanges must be Class 125 ANSI standard. Base elbow suction and discharge size must be as noted in Part 2.07 of this section.

- O. Coatings: Pumps, bases, suction elbows, frame, and other ferrous components must be sandblasted per SSPC-SP6 and coated with two coats of Tnemec 431 epoxy for a total minimum DFT of 30 mil. Pump manufacturer may submit an alternate equivalent coating system.
- P. Data Plates: Each pump must be furnished with a stainless steel nameplate fastened with screws. The plate must be stamped with the pump manufacturer, serial number, design nominal speed, horsepower, installed and maximum impeller diameter, design total dynamic head in feet, and design flow in gallons per minute.
- Q. Nozzle Vent: Install 3/4" brass ball valve and fittings in the nozzle top side tapping boss. Furnish with rubber hose of sufficient length to reach dry well sump.

2.04 MANUFACTURER

- A. Pump manufacturer or their authorized distributors must have 24/7/365 service capabilities and maintain a full-service shop with 25 miles of the Project Site.
- B. Pumps must be by Vaughan Co. of Montesano, WA or approved equal.

2.05 PUMP MOTORS

- A. Motor Design:
 - 1. The motors must be of the squirrel cage induction type, vertical solid shaft, C-Flange Base, 1.15 S.F., TEFC, and suitable for continuous severe duty operation at full load rating not to exceed 40 degrees Centigrade ambient temperature. The motors must not be overloaded beyond its full load rating by the pump at any operating condition on the pump characteristic curve and suitable for operating with reduced voltage soft start controllers between 100% and 50% of full speed, across-the-line start, and/or variable frequency drive applications. Inrush current must not exceed 6 KVA per rated horsepower, NEC Design code G. Motors must be designed for frequent repetitive starting, with a cycle time of 10 minutes.
 - 2. The motors must operate successfully under running conditions at rated load with variation in the voltage or the frequency not exceeding the following conditions:
 - a. +/-10% rated voltage at rated constant volts/hertz ratio, except for specific torque boost starting applications
 - b. +/-5% rated frequency at rated constant volts/hertz ratio
 - c. Successful operation under the voltage unbalance at the motor terminals that does not exceed 1%
 - 3. The motors must be designed to withstand a 5% overspeed in either direction of rotation. Motor torques must comply with ANSI/NEMA MG1-20.41.
 - 7. Motors must be designed with class "F" insulation rating or better, suitable for a maximum temperature of 155 degrees C.
 - 8. The motor must be dynamically balanced, and fan cooled. The use of solder or similar deposits is not acceptable. Any parent metal removed to achieve

dynamic or static balance must be removed in a manner which will maintain the structural integrity of the rotor.

9. The motors must be NEMA Design "B" with Premium Efficiency type with a minimum guaranteed efficiency > 93% and power factor > 80% at full load. Motors must have a maximum temperature rise at continuous full load of 80 degrees by resistance measurement. Efficiency and temperature rise must be stamped in the nameplate. Efficiency must be demonstrated with certified tests in accordance with the Standards: IEEE test procedure 112, Method B.
10. The motor must have a safe stall (locked rotor) time equal to or greater than that maximum accelerating time under worst voltage condition.
11. The motor must have a maximum peak-to-peak amplitude of vibration in accordance with MG1 20.52 and sound pressure levels not to exceed 85dbA at 3 feet from the motor.

C. Bearings:

1. Bearings must be anti-friction type, ball bearing, double shielded (code ZZ) and lubricated of adequate capacity to assure a minimum L-10 life of 50,000 hours. Anti-friction bearings must be made from vacuum degassed steel.
2. Bearing and corresponding lubricant must capable of assuring the minimum service as stated above. Where lubricant is grease, the bearings must have readily accessible grease inlet and outlet fittings in the bearing housing to allow regreasing from the exterior. Where lubricant is oil, oil bath must be fitted with suitable sight glass, and arranged to prevent the entry of oil or oil vapor to the motor windings.
3. Bearings must be protected from shaft current produce by common mode voltages and other electromagnetic interference.

D. Motor Construction:

1. Frame must be of fabricated carbon steel and end bells must be made of heavy duty, impact resistant cast iron. Motor terminal boxes for conduits and wire connections as specified must be over-sized meeting volumes provided in IEEE 841 or a minimum of 1200 cubic inches, with standard threads. Metric threads will not be accepted. Terminal boxes must be diagonally split, rotatable in 90⁰ increments, and attached to the motors frame with high strength zinc plated and chromated steel bolts and cap screws. Grounding lug/terminal and ungrounded terminals inside terminal boxes must allow use of 75⁰C rated conductors.
2. The motor mechanical design and coil bracing must be suitable for full voltage starting and also 5 cycle bus transfer as a precaution against possible high-speed reclosing. End coil bracing must be in place before VPI process. Insulation system must be rated type "F" or better, suitable for maximum average temperature of 155 degrees C or higher. Individual turns in the starter coils must be insulated with Class "H" enamel covered with two layers of polyester and glass yarn.
3. Motor must be sized such that it will deliver full rated power and service factor at its rated temperature rise if the motor is later rewound, by a motor shop approved by the motor manufacturer, using conventional insulation.

4. The enclosure must provide access to the interior parts of the motor for inspection or minor cleaning without a major disassembly of the motor. End-shields and bearing housings must be provided to permit bearing and winding inspection without the need for realignment. Motor vent openings must have removable stainless steel guard screens and inlet air filters with stainless steel media.
5. Lifting lugs must be furnished, designed in accordance with NEMA MG 2-2.02.
6. All hardware must be made of 316 stainless steel.
7. Exposed surfaces must be protected with at least two coats of epoxy type paint after the surface has been cleaned and primed according to the instructions of the epoxy paint manufacturer. Motor vent openings must have stainless steel guard screens and inlet air filters with stainless steel or aluminum media. Finish color must be light gray conforming to ANSI 61.

E. Stator:

1. The complete stator must be a sealed system which receives at least two complete vacuum pressure impregnation process cycles of 100% solids epoxy resin. Windings must be copper and provided with a polyurethane dispersion to inhibit insulation abrasion by sand, salt, fly ash or other abrasive materials entrained in the cooling air.
8. Stator and rotor core pieces must be machine stamped from low loss non-aging silicon steel. Laminations must be insulated by a layer of varnish or enamel.

F. Rotor Shaft:

9. Rotor shafts must be designed for maximum strength and rigidity and must be manufactured from carbon steel meeting SAE standard for 1045 steel.
10. For the rotor shaft, the critical speed must be a minimum of 20% above the rated motor speed.
11. Motors must be provided with a shaft grounding device (typical requirement for motors 30hp or larger)

2.06 TOOLS AND SPARE PARTS:

A. Special Tools:

1. Furnish, together with the pumping units, 1 set of any special tools, other than common plant mechanic's tools, necessary to install, adjust, maintain or repair the pumping units or any of the components.

B. Spare Parts:

1. Furnish parts list with manufacturer's part numbers for all replaceable pump, driver, and motor components. Furnish separate recommended parts list for pump overhaul.
2. Furnish one (1) spare set of mechanical seals for each pump supplied.

2.07 ANCHOR BOLTS

- A. Anchor bolts must be constructed of Type 316 stainless steel

- B. Furnish anchor bolts of the type, size, and dimensions shown in the approved seismic anchorage calculations.

2.078 PUMP SCHEDULE

- A. Furnish pumping units in accordance with the tables below. The station normally operates with 1 pump, but will occasionally operate with 2 pumps running in parallel during high flow events. The Primary Duty Point represents the most common wet well level for operation.
- B. Pump model and impeller trim must be selected such that the pump is capable of operating at the stated duty conditions while within the Preferred Operating Region of 70%-120% of the pump's Best Efficiency Point flow.

LOCATIONPS 118		
Pump Quantity	2	
	Primary duty point, One Pump Running	Secondary duty point Two Pumps Running
Duty Points	XXX gpm XXX TDH XXX NPSHA 310 GPM 24' TDH 35.8 NPSHA	XXX gpm XXX TDH XXX NPSHA 230 GPM (per pump, 460 GPM total flow) 26' TDH 35.6' NPSHA
Nominal Speed, RPM	1,200	
Minimum Efficiency at Duty Point, %	45	35
Motor Horsepower, HP	7.5	
Discharge Size, in.	4	
Suction Size, in.	6	
Configuration	[Vertical Coupled, Horizontal Coupled, etc] Vertical Coupled	
Discharge Configuration	Centerline [Centerline, tangential]	

- C. The Owner intends to operate Pump Station 118 in both single and parallel configuration, and transition between configurations on a regular basis. The supplied pumps must be capable of meeting both duty points shown.
- D. Manufacturer's NPSH required at the given operating points must not exceed 50% of the given available NPSH.

2.098 WARRANTY

- A. Pumps must be warrantied for a period of 2 full years after date of commissioning.

PART 3 - EXECUTION

3.01 TESTING, GENERAL

- A. The tests of the pumping units are divided into four parts: Hydrostatic tests of pump component parts at the pump factory, tests of the motors at the motor factory, tests of the assembled pumps at the factory, and final acceptance tests to be conducted after installation.
- B. Tests must be scheduled only after the factory has pre-tested the unit and submitted preliminary test data that has been deemed satisfactory by the Engineer of Record.
- C. Factory pump testing acceptance criteria must be per Hydraulic Institute Standard 14.6 Grade 1U.
**[Designer to specify appropriate HI Grade for pump testing:
 Typically,
 8" and larger pumps – Grade 1U
 6" pumps – Grade 1E
 4" pumps – Grade 2B]**
- D. Test reports certified by a manufacturing company representative who is a Registered Professional Engineer in the State of Washington.

The tests of the pumping units are divided into four parts: Hydrostatic tests of pump component parts at the pump factory, tests of the motors at the motor factory, tests of the assembled pumps at the factory, and final acceptance tests to be conducted after installation.

- B. Tests must be scheduled, only after the factory has pre-tested the unit and submitted preliminary test data that has been deemed satisfactory by the Engineer of Record.

3.02. HYDROSTATIC TEST OF PUMP COMPONENTS

- A. Pump must be hydrostatically tested to 1.25 times the shutoff pressure at the listed operating speed for the largest impeller trim available for the pump, regardless of actual installed trim.

3.03 MOTOR TEST

- A. Routine factory certified tests must be given to each motor as required by NEMA and ANSI Standards. Tests must be performed in accordance with IEEE Standard No. 112A "Test Procedures for Polyphase Induction Motors and Generators".

1. At minimum, report list of tests:

Description	Factory Test	Standards
Winding resistance cold	x	IEEE 112
Test with locked rotor	x	IEEE 112

Description	Factory Test	Standards
Temperature rise	x	IEEE 112
Load test: Full load, 75% load, 50% load, no load	x	IEEE 112
High potential test	x	IEEE 112
Breakdown torque test	x	IEEE 112
Speed-Torque curve	x	IEEE 112
Insulation resistance test	x	IEEE 112

- B. In addition to the above, factory tests must include sound level and peak-to-peak amplitude of vibration. Pull-in and pull-out torque must be determined. Tests must be made according to standard NEMA procedures and certified copies of reports and speed-torque curves must be furnished to the Owner before pump delivery.
- C. The motor must be tested for vibration at no load and at rated voltage and frequency. The maximum allowable peak-to-peak amplitude of vibration on the bearing chambers must be 2.0 mils.

3.04 FACTORY PUMP TESTING

- A. The pump must be tested to develop the performance curves and for assurance of proper and vibration free operation.
 - 1. Data gathering must be in accordance with Hydraulic Institute Standards. Curves must be plotted using the data obtained at the tests. All curves must extend from shut-off to actual runout points. Curves must include: head vs. capacity, brake horse power, mechanical efficiency and wire to water efficiency. There should be a minimum of 5 test points spaced at approximately equal head, with one test point at the designated duty point for that pump.
 - 2. Vibration must be continuously monitored and recorded during all pump tests.

3.04 FACTORY PUMP TESTING

- A. Factory pump testing beyond the manufacturer's normal quality control/assurance processes is not required for pumps covered under this Section.

3.05 FIELD ACCEPTANCE TESTING

- A. Field tests and assistance must be provided by service technicians from the manufacturer or their authorized distributor (see **Article 2.04** of this Section), experienced in each kind of equipment installed, and for each specific function.
- B. For equipment start-up and acceptance tests, the factory representative must supervise the start-up and acceptance testing of each pumping unit, as described below. The pumping unit will be subjected to operational testing under a variety of conditions including low NPSHA and various discharge heads to verify the factory performance

curve. Also included must be vibration measurement tests as described in other paragraphs of this subsection of the Specifications. The factory representative's service technicians must perform all final alignment and adjustments necessary for the best possible operation.

- C. At the end of each start-up and acceptance tests, including vibration measurements, the Engineer and the factory representative will jointly analyze the test data. If all evidences prove that the installation is correct, the factory representative must issue a certification which must be stamped by a Registered Professional Civil engineer licensed in the state of Washington. Upon acceptance of the Engineer of the statements in the certification, the unit will be considered accepted.

3.06 INSTALLATION

- A. All of the equipment specified in this Section must be installed in strict accordance with this Section, the instructions received from the manufacturers, **Section 40 05 02 – Equipment Mounting and Section 40 05 03 – Machine Alignment**. Workmanship and miscellaneous materials must follow the best standards of quality recognized for the trades involved. Where there may be conflicts between the Specifications and manufacturer's instructions, this must immediately be brought to the attention of the Engineer, who will issue orders resolving the conflict. The Engineer's decision will be final and binding for all involved parties.
- B. After mounting and installing pump, route discharge nozzle vent hose to dry well sump.

End of Section 43 21 14

SPECIFICATION SECTION 43 21 14

REINSTALLATION OF SALVAGED VERTICAL CENTRIFUGAL PUMPS

PART 1 - GENERAL

29.02 SUMMARY

- A. Section Includes:
1. Removal and re-installation of salvaged wastewater pumps at **[INSERT LOCATION HERE]**
- B. Related Sections include but are not necessarily limited to:
1. Division 00 - Procurement and Contracting Requirements
 2. Division 01 - General Requirements
 3. Section 01 75 00 – Commissioning and Site Acceptance
 4. Section 40 05 02 – Equipment Mounting
 5. Section 40 05 03 – Machine Alignment

29.03 QUALITY ASSURANCE

- A. Referenced Standards:
1. Hydraulic Institute (HI):
 - a. Standards for Centrifugal, Rotary and Reciprocating Pumps.
 2. Underwriters Laboratories, Inc. (UL):
 3. Seattle Public Utilities Pump Station Design Standards and Guidelines.

29.04 SCOPE OF WORK

- A. The Contractor's scope of Work for this Section includes, at each **[CONTRACT LOCATION]**:
1. Removal and salvage of **[INSERT NUMBER]** electric motors ranging between **[INSERT NUMBER]** horsepower.
 2. Removal and salvage of **[PUMP QUANTITY, SIZE]** vertical centrifugal wastewater pumps, including base elbows, bearing frames, and motor brackets.
 3. Storage and protection of salvaged pumps and motors either at the Project Site or Contractor's off-site secure storage.
 4. Re-installation of salvaged pumps on new anchor pads and connections to process piping as shown in the Drawings.
 5. Provision of startup, testing, and commissioning services by a manufacturer's authorized representative retained by the Contractor.
 6. Prep and paint 2 pumps per **Section 09 90 00 – Painting and Coatings, Article 3.09**.

- B. It is the intent of these Specifications to obtain complete and operable equipment. The Contractor must furnish all items and accessories shown in the manufacturer's literature as standard, as modified herein, which have not been furnished by the Owner. Since it is not possible to name every single component, all accessories necessary to accomplish the intent of these Specifications must be included as if they were specifically mentioned herein.
- C. All equipment and accessories must be of the highest quality available in the industry, and assembly and installation must show the highest quality of workmanship available in the respective trades.
- D. All equipment furnished must be new, unused, the products of manufacturers having a minimum of 20 years of experience in manufacturing, marketing and servicing units similar to those offered.
- E. The Contractor must ensure that reinstalled equipment is in equal to or better condition than at the time it was removed. The Contractor is not responsible for correcting existing cosmetic or functional defects present at the time of salvage. Pump performance and testing data gathered by the Contractor during startup testing and commissioning will be used only for comparison against the condition of the equipment at the time of removal.

29.05 SUBMITTALS

- A. Procedures: See **Section 01 33 10 - Submittals** for requirements for the mechanics and administration of the submittal process.
- B. A copy of this specification section, with addendum updates included, and all referenced and applicable sections, with addendum updates included, with each paragraph check-marked to indicate specification compliance or marked to indicate requested deviations from specification requirements. Check marks (✓) denote full compliance with a paragraph as a whole. If deviations from the specifications are indicated, and therefore requested by the Contractor, underline each deviation and denote by a number in the margin to the right of the identified paragraph, referenced to a detailed written explanation of the reasons for requesting the deviation. The Engineer is the final authority for determining acceptability of requested deviations. The remaining portions of the paragraph not underlined will signify compliance on the part of the Contractor with the specifications. Failure to include a copy of the marked-up specification sections, along with justification(s) for any requested deviations to the specification requirements, with the submittal is sufficient cause for rejection of the entire submittal with no further consideration. Technical acceptance of a requested deviation does not constitute an approval of added costs.
- C. Equipment Removal and Protection Plan: A written description of the Contractor's proposed methods to remove, transport, securely store, and protect salvaged equipment. Methods must be in accordance with the equipment manufacturer's recommended best practices for rigging, lifting, transportation, storage, and protection. This plan must include detailed photos of equipment to be salvaged documenting its condition, including any obvious defects, prior to disconnection and removal. Photos must be taken from all sides. Minimum 8 photos per pump and motor set.
- D. Catalog cuts, shop drawings, or any other technical information for any components supplied by the Contractor.
- E. Written confirmation from the pump manufacturer or manufacturer's representative that any Contractor-supplied parts and equipment are compatible with the Owner furnished equipment.

- F. Qualifications of firm that will be providing start-up testing and commissioning support, including certification as an authorized manufacturer’s representative.
- G. Pump startup and testing plan meeting the requirements of this Section along with pump manufacturer’s recommended procedures.
- H. Calibration certificates for all equipment used in start-up testing (e.g. pressure gauges, alignment tools).
- I. Startup testing report showing results of all startup testing including, including calculated pump curve, performance data, vibration records, and alignment records.

PART 2 - PRODUCTS

2.01 GENERAL

- A. The following components must be furnished by the Contractor:
 - 1. Other miscellaneous components required for assembly and operation of the salvaged pumps as listed by the manufacturer, including, but not limited to, anchor bolts, bolts, nuts, gaskets, couplings, fittings, grease, or other items.
 - 2. Replacement polyethylene hoses (3/4” diameter) for discharge nozzle vent fittings of sufficient length to reach the dry well sump.

2.02 EXISTING PUMP SCHEDULE

- A. The following information is provided for the Contractor’s reference only to show the existing equipment to be salvaged at each site.
[DESIGNER TO COMPLETE SALVAGE SCHEDULE IN ACCORDANCE WITH PROJECT SCOPE]

Station		
Manufacturer		
Model		
Motor Size		
Pump 1 S/N		
Pump 2 S/N		
Existing Operating Flow (single pump)		

2.03 WARRANTY

- A. A warranty, limited to parts and labor specific to the Work performed under this Section, must be provided per **Section 00 72 00 – General Conditions**.

PART 3 - EXECUTION

3.01 GENERAL

- A. Do not begin pump removal until temporary sewer bypass is established per **Section 01 35 05 – Sewer Bypass Plan**.

3.02 REMOVAL, SALVAGE, AND STORAGE

- A. Remove and salvage existing pumps, bearing frames, bases, motors, power cables, sensor cables (if applicable) and Meltric plug connectors. Additional components for removal and salvage may be noted on the Drawings.
- B. Transport, store, and protect salvaged materials per the approved Plan.

3.03 RE-INSTALLATION OF EQUIPMENT

- A. All of the equipment specified under this Section must be installed in strict accordance with this Section, the instructions received from the manufacturers, **Section 40 05 02 – Equipment Mounting**, and **Section 40 05 03 – Machine Alignment**. Workmanship and miscellaneous materials must follow the best standards of quality recognized for the trades involved. Where there may be conflicts between the Specifications and manufacturer's instructions, this must immediately be brought to the attention of the Engineer, who will issue orders resolving the conflict, and its opinion will be final and binding for all involved parties.
- B. Construct new mounting pads and anchors as shown in the Drawings.
- C. Install components, assemble pumps, adjust all clearances and verify equipment alignment per the manufacturer's instructions.
- D. Connect pumps to process piping, install new bleeder hoses and route to sumps.
- E. Connect motors and bump test pumps to verify rotation direction prior to beginning start-up testing.

3.04 FIELD STARTUP TESTING

- A. Field tests and assistance must be provided by service technicians from the manufacturer or their authorized distributor, experienced in each kind of equipment installed, and for each specific function.
- B. All temporary equipment required for testing (e.g. pressure gauges, vibration monitors) must be furnished, installed, and removed by the Contractor.
- C. Bump-test motors and pumps to verify proper rotation prior to beginning operational testing.
- D. Each pumping unit will be subjected to operational testing under a variety of conditions including low NPSHA, various discharge heads, and various speeds to verify the factory performance curve. Shutoff head testing must be included. At least 5 points must be checked. Pump suction and discharge pressures must be recorded for each point. Vibration testing must be performed per Hydraulic Institute requirements to establish baseline values for future maintenance activities. The factory representative's service technicians must perform all final alignment and adjustments necessary for the best possible operation.

- E. Testing report to the Engineer must include: Vibration monitoring results, measured pump curve, motor voltage and amperage on each phase, motor unloaded voltage, and motor winding resistance, and record of alignment.
- F. At the end of each start-up test, including vibration measurements, the Engineer and the factory representative will jointly analyze the test data. Upon acceptance of the Engineer that the testing is complete, the unit will be considered accepted.

END OF SECTION 43 21 14

SPECIFICATION SECTION 43 21 39

SUMP PUMPS

PART 1 - GENERAL

1.01 SUMMARY

- A. Section Includes:
1. Furnish and install sump pumps and accessory float switches as shown on the Drawings.
- B. Related Sections include but are not necessarily limited to:
1. Division 00 – Procurement and Contracting Requirements
 2. Division 01 – General Requirements
 3. Section 01 33 10 – Submittals

1.02 SUBMITTALS

- A. Action Submittals:
1. Make, model, weight, and horsepower of each equipment assembly.
 2. Complete catalog information, descriptive literature, specifications, and identification of materials of construction.
 3. Performance data curves showing head, capacity, horsepower demand, and pump efficiency over the entire operating range of the pump, from shutoff to maximum capacity. Indicate separately the head, capacity, horsepower demand, overall efficiency, and minimum submergence required at the guarantee point.
 4. Power and control wiring diagrams, including terminals and numbers.
 5. Factory finish system.
- B. Informational Submittals:
1. Special shipping, storage and protection, and handling instructions.
 2. Manufacturer's printed installation instructions.
 3. Suggested spare parts list to maintain the equipment in service for a period of 5 years. Include a list of special tools required for checking, testing, parts replacement, and maintenance with current price information.
 4. List special tools, materials, and supplies furnished with equipment for use prior to and during startup and for future maintenance.
 5. Operation and Maintenance Data

PART 2 – PRODUCTS

2.01 PUMPS

- A. Manufactured by Pentair/Hydromatic or approved equal.

- B. Pump must be a cast iron, non-clog submersible suitable for immersed operation in wastewater. It must be capable of passing 1-1/2-inch or larger solids and must have a minimum 2-inch discharge outlet.
- C. The pump must be capable of both manual and automatic operation.
- D. The pump must be suitable for operation in an 18-inch diameter sump.
- E. The pump must be compatible with the switch and power type specified in this Section.
- F. Pump must be furnished with an integral power cord and plug that is sealed/potted at the connection to the pump body. Plug must be suitable for a NEMA 5-20R receptacle. Hardwired pumps are not acceptable.
- G. Where pumps are shown in the Drawings or Pump Schedule to be installed in areas with an electrical hazard classification (as defined by NFPA 820), furnish pumps and equipment rated for the specified environment.
- H. Pump Schedule: See Mechanical Schedules in the Drawings.

2.02 SWITCHES FOR SUMP PUMPS

- A. Switches must be adjustable float switches, of the piggyback style.
- B. Switches must be suitable for the for the specified sump pump power type and must plug into a NEMA 5-20R style receptacle.

PART 3 - EXECUTION

3.01 INSTALLATION

- A. Install in accordance with manufacturer's printed instructions.
- B. Connect discharge piping without imposing strain on piping or pump. Provide threaded union coupling 1 foot above floor (max) for disconnecting pump.

3.02 FIELD QUALITY CONTROL

- A. Functional Tests: Conduct on each pump.
 - 1. Alignment: Test complete assemblies for correct rotation, proper alignment and connection, and quiet operation.
 - 2. Flow Output: Measured by storage volumes.
 - 3. Operating Temperatures: Monitor bearing areas on pump and motor for abnormally high temperatures.
 - 4. Flow test for duration as directed by the Engineer.

End of Section 43 21 39