

# Chapter 6 Cathodic Protection

<b>Chapter 6 Cathodic Protection .....</b>	<b>6-1</b>
<b>6.1 Key Terms .....</b>	<b>6-1</b>
6.1.1 Abbreviations .....	6-1
6.1.2 Definitions .....	6-2
<b>6.2 General Information .....</b>	<b>6-4</b>
6.2.1 Users of this Chapter .....	6-5
6.2.2 Policy .....	6-5
Removed for Security	
6.2.5 Design Resources .....	6-6
<b>6.3 General Requirements .....</b>	<b>6-6</b>
<b>6.4 Basis of Design .....</b>	<b>6-7</b>
6.4.1 Basis of Design Plan Sheet .....	6-7
6.4.2 Design Criteria List .....	6-8
6.4.3 Types of Systems .....	6-9
<b>6.5 How to Use This Chapter .....</b>	<b>6-9</b>
6.5.1 SPU Procedure for Selecting Cathodic Protection .....	6-10
6.5.2 Design Issues .....	6-11
<b>6.6 Design Process .....</b>	<b>6-12</b>
6.6.1 Planning the Project .....	6-12
6.6.2 Selecting Test Procedures .....	6-16
6.6.3 Initial Testing .....	6-16
6.6.4 Monitoring .....	6-18
<b>6.7 Design Guidelines .....</b>	<b>6-18</b>
6.7.1 DG1 - Deep Anode Groundbed .....	6-19
6.7.2 DG2 - Semi-Deep Anode Groundbed .....	6-25
6.7.3 DG3 - Distributed/Point Anode Groundbeds .....	6-31
6.7.4 DG4 - Point Galvanic Anode .....	6-37
6.7.5 DG5 - Linear Anode Groundbed .....	6-40
6.7.6 DG6 - Water Tank (Galvanic) .....	6-45
6.7.7 DG7 - Water Tank (Impressed Current) .....	6-49
6.7.8 DG8 - Grid Type (Impressed Current) .....	6-54
6.7.9 DG9 - Rectifier Installation/Selection .....	6-54
6.7.10 DG10 - Pipe/Casing Test Station .....	6-59
6.7.11 DG11 - Joint Bonding .....	6-60
6.7.12 DG12 - Interference/Monitoring Test Stations .....	6-63
6.7.13 DG13 - Coupon Test Stations .....	6-66
6.7.14 DG14 - Linear Galvanic Anodes, Linear Grounding Ribbon Anodes, and Grounding Mats .....	6-69

Removed for Security

Removed for Security

**6.9 Resources..... 6-177**

**Appendices**

Appendix 6A - CSI Specifications for Cathodic Protection

**List of Figures**

Figure 6-1 Basis of Design Plan Sheet Data for Cathodic Protection ..... 6-8  
Figure 6-2 SPU Design Process for Cathodic Protection..... 6-10  
Figure 6-3 Cathodic Protection Analysis for Existing Water Tank ..... 6-14  
Figure 6-4 Cathodic Protection Analysis for Existing Pipeline..... 6-15  
Figure 6-5 Typical Galvanic Anode Water Tank Installation..... 6-47  
Figure 6-6 Typical Galvanic Anode Junction Box without On/Off Switch ..... 6-49  
Figure 6-7 Anode Positioning ..... 6-52  
Figure 6-8 Typical Rectifier Installation ..... 6-55  
Figure 6-9 Typical Pipeline/Casing Installation (Test stations can be installed on both ends as needed) .. 6-59  
Figure 6-10 Typical Test Station for Pipeline/Casing Testing..... 6-60  
Figure 6-11 Typical Concrete Cylinder Pipe Installation..... 6-61  
Figure 6-12 Typical Weld Mold with Instructions..... 6-62  
Figure 6-13 Sample Interference Test Station Schematic (SPU currently does not have any Interference Test Stations) ..... 6-65  
Figure 6-14 General Schematic of Foreign Line Crossing – Side View..... 6-65  
Figure 6-15 General Schematic of Foreign Line Crossing – Top View..... 6-66  
Figure 6-16 Coupons and Test Station ..... 6-67  
Figure 6-17 Coupon Test Stations ..... 6-69

Removed for Security

Removed for Security

**List of Tables**

Table 6-1 Design Criteria List for Cathodic Protection (Example).....6-8  
Table 6-2 Cathodic Protection (Impressed Current) Issues Comparison for SPU Pipeline Systems<sup>1</sup> .....6-11  
Table 6-3 Cathodic Protection Systems Used in SPU Water Tanks.....6-12  
Table 6-4 SPU DGs for Cathodic Protection.....6-19  
Table 6-5 Advantages and Disadvantages of Deep Anode Groundbeds.....6-19  
Table 6-6 TPs Related to Deep Anode Groundbeds .....6-20  
Table 6-7 Advantages and Disadvantages of Semi-Deep Anode Groundbeds .....6-26  
Table 6-8 Advantages and Disadvantages of Distributed/Point Anode Groundbeds.....6-32  
Table 6-9 Advantages and Disadvantages of Linear Anode Groundbed .....6-40  
Table 6-10 Anode Consumption Rates<sup>1</sup> .....6-51

Removed for Security

# Chapter 6 CATHODIC PROTECTION

This chapter of the Design Standards and Guidelines (DSG) presents standards and guidance for testing external corrosion control of Seattle Public Utilities (SPU) facilities. The primary audience for this chapter is City of Seattle (City) engineering staff responsible for cathodic protections design. DSG standards are shown as underlined text.

Removed for Security

For detailed instructions regarding how to use this chapter, see DSG section 6.5.

## 6.1 KEY TERMS

Abbreviations and definitions given here follow either common American usage or regulatory guidance.

### 6.1.1 Abbreviations

Abbreviation	Term
AC	alternating current
AMPP	AMPP The Association for Materials Performance and Protection, formerly NACE
AWWA	American Water Works Association
CFR	Code of Federal Regulations
CSA	Canadian Standards Association
CSE	copper sulfate electrode
CSI	Construction Specifications Institute
DC	direct current
DG	design guideline
DSG	Design Standards and Guidelines
ft	feet
GIS	geographic information system
ISO	International Standards Organization
NACE	National Association of Corrosion Engineers, now known as NACE International, the worldwide corrosion authority
O&M	operations and maintenance

Abbreviation	Term
ROW	right-of-way
SPU	Seattle Public Utilities
TP	test procedure
ZRE	zinc reference electrode

## 6.1.2 Definitions

This list of definitions is for the key terms only. Terms for specific DGs and TPs are defined at the beginning of the section about those subjects.

Term	Definition
alternating current	Electrical current flow which periodically reverses direction.
anode	The electrode or terminal by which current enters an electrolytic cell, voltaic cell, or battery. The negative terminal of a voltaic cell or battery.
autopotential rectifier	Transformer rectifier that incorporates a stationary reference electrode within its autopotential circuitry to maintain direct current (DC) output based on a user-set potential.
calibration electrode	A reference electrode that is used solely for verifying the accuracy of a portable field reference electrode. The calibration electrode is not used for field testing or otherwise exposed to any other electrolyte except as outlined in the reference electrode calibration procedures.
cathodic protection	A technique used to provide corrosion control to buried or submerged metallic materials. Application of adequate cathodic protection results in shifting the potential of all anodic sites on the structure in the negative direction, thus retarding the discharge of electrical current off of the structure.
chainer	A unit used in conjunction with a data logger used to dispense structure connection wire along the pipeline right-of-way. The chainer prompts the data logging equipment to record potential measurements at a predetermined footage interval (such as 2.5 feet [ft] or 5.0 ft).
clamp-on ammeter	Equipment that measures the intensity of the magnetic field developed within an electric conductor due to the flow of electronic current. Magnitude and direction of current flow is displayed on the meter output screen.
constant current rectifier	Transformer rectifiers designed to provide constant DC current output as output circuit resistance changes. Rectifier current output is kept at a constant level by automatic adjustment of the DC voltage.
constant voltage rectifier	Transformer rectifiers designed to provide constant DC voltage output regardless of other influences within the DC output circuit. DC voltage outputs are changed by adjusting the secondary alternating current (AC) voltage.
conventional current flow	Direction of positively charged ion migration in the electrolyte.
current shunt	Equipment installed in series with a cathodic protection current source. Current shunts have a known electrical resistance which, when divided by the measured voltage drop across them, allow for the calculation of current flow in accordance with Ohm's Law.
data logger	An electrical device capable of measuring multiple electrical parameters and storing the data within a memory for later retrieval.

Term	Definition
design guideline	For this chapter, refers to specific requirements for cathodic protection system design and standard installation methods. Each DG incorporates information from specific TPs. See test procedure.
direct current	Electrical current flow that continues in a certain direction.
distilled water	Water from which ions have been removed.
dynamic stray current	Stray current that varies in both magnitude and direction over time. Sources of dynamic stray current include DC light rail systems and high-voltage electrical transmission lines.
electrically continuous	Possessing the ability to allow electronic current to flow from one location to another in a metallic path.
electrically isolated	A condition that will not allow for the flow of electronic current between metallic structures. Intentional electrical isolation is often provided by electrical isolation kits or electrical isolation unions.
electrolyte	A medium that supports the flow of ionic current, most often soil or water.
electronic current flow	The migration of electrons from the anode to the cathode within the cathodic protection metallic circuit.
far ground potential	An electrical potential measured with the structure connection and the reference electrode some distance apart. This will often be with the structure connection at one test station and the reference electrode located at an adjacent test station (which may be separated by several thousand ft).
foreign structure	A facility (most often a pipeline) that is not intended to be part of the cathodic protection circuit.
galvanic anode	Type of cathodic protection system that relies on the electrochemical potential difference between metals to force current from a location of active potential to a location of noble potential. Typically, a galvanic anode cathodic protection system is a standard battery. Because they have limited driving potential, galvanic anode systems are used where only a limited amount of protective current is needed (e.g., short spans of well-coated pipeline or the internal surfaces of coated water storage tanks). Metallic materials (generally magnesium, zinc, and aluminum), which are more electronegative (anodic) than the facilities that they are electrically continuous with, result in current flow to the cathodic sites.
hot spot	An isolated location that is not receiving adequate cathodic protection current on a structure that otherwise meets criteria for effective corrosion control. Hot spots may occur at locations where the soil conditions are drastically different (such as swampy ground or locations of concentrated bacteria), specific locations of damaged coating, or where stray current is being discharged from the structure.
hot spot protection	The installation of a galvanic anode at a specific location to provide isolated protection at the installation site. This may include areas of low resistivity soils and isolated areas that do not meet criteria for effective corrosion control.
impressed current	Type of cathodic protection system that uses an external power source (usually a transformer rectifier) to force protective current onto facilities requiring corrosion protection. Typically used for transmission mainlines, the wet internal surfaces of water storage tanks, or on soil side surfaces of at-grade storage tanks.
instant-off potential	Electrical potential measured with the cathodic protection current momentarily switched off, allowing for the accurate measurement of the structures polarized potential.
multimeter	Instrument used to measure a variety of readings pertaining to cathodic protection and corrosion control. Typical measurement functions including AC and DC voltage, AC and DC amperage, and resistance.

Term	Definition
native potential	Electrical potential measured on a structure prior to the application of cathodic protection current. Typically, the structure will reside in the environment for a couple of weeks before an electrochemical 'equilibrium' will be achieved (time at which the electrical potential remains constant between testing intervals). This 'equilibrium' potential should be recorded as the native potential.
Ohm's Law	Ohm's Law states that the voltage drop in an electrical circuit is equivalent to the current flow multiplied by circuit resistance.
on potential	Electrical potential measured with cathodic protection current applied to the structure. This potential measurement, including an error, is a result of current flow in the electrolyte.
near ground potential	An electrical potential measured with the reference electrode placed adjacent to the structure's negative connection.
pH	A measurement of the ratio of hydrogen ion concentration to hydroxyl ion concentration in an electrolyte.
pipe-to-soil potential	See structure-to-electrolyte potential.
polarized potential	Often referred to as an Instant OFF potential, the polarized potential is the electrical potential of a metallic structure under the influence of cathodic protection, with all current sources affecting the measurement accounted for. The polarized potential is the potential measured across the structure to electrolyte boundary that is the summation of the structure's native potential and cathodic polarization at the tested location.
portable reference electrode	A rugged field instrument used to measure the relative electrical potentials of metallic structures. The most common forms of portable reference electrodes include copper sulfate, silver chloride, and zinc.
resistance	The opposition to current flow, measured in ohms.
resistivity	The resistance per unit length of a substance with a uniform cross-section. Relates a conductor's resistance to its geometry.
static stray current	Stray current that maintains generally constant magnitude and direction. The prime source of static stray current is the operation of nearby cathodic protection systems.
stationary reference electrode	A reference electrode that has been installed in a permanent location, often near the surface of the structure being tested. Many times, the potential of a structure can change with just slight movement of the electrode. Stationary reference electrodes allow for the structure-to-electrolyte measurement at consistent locations.
structure-to-electrolyte potential	Electrochemical potential difference between a metallic object and its surrounding electrolyte, which is measured in reference to an electrode contacting the same electrolyte.
test procedure (TP)	Tps are steps or calculations for data collection, monitoring, and testing of SPU cathodic equipment. Tps accompany the DGs.
test station	Established location where structure-to-electrolyte potentials are measured on a routine basis.

## 6.2 GENERAL INFORMATION

This section describes general information for corrosion control design at SPU, including policy, system maps, and existing installations for corrosion control at SPU.

## 6.2.1 Users of this Chapter

The TPs included in this document have been developed for individuals who have a basic understanding of cathodic protection. **Removed for Security**

**Removed for Security** Technicians responsible for collection and basic analysis of field data should be able to operate electrical testing equipment such as digital multimeters and soil resistance meters. SPU recommends the following experience levels:

- Users of TPs have a minimum one year of experience under the guidance of an individual experienced in general corrosion control testing and monitoring.
- Individuals who design cathodic protection systems in accordance with the DSG should have a minimum five years of experience collecting field data, CP system installations and maintenances, and conducting standard cathodic protection system monitoring.
- Additional experience needed includes three years of cathodic protection design, the ability to analyze CP system performance and perform advanced algebra, and a sound understanding of cathodic protection system installations.

## 6.2.2 Policy

SPU policy for corrosion control is to provide an economic justification for implementing any corrosion control strategy. These strategies follow asset management principles and cost accounting review and are generally based on weighing lifecycle extension estimates against added cost.

Policy decisions for corrosion control must also account for sound engineering principles such as maintaining structural integrity, safety, and reliability in the design of a particular project. At times engineering considerations may conflict with an economic justification for a project. However, where known corrosion exists that could jeopardize safety factors, a system of corrosion protection should be considered to prevent environmental and community concerns that can arise from corrosion-related structural failure.

**Removed for Security**



Removed for Security

#### 6.2.4.2 Corrosion Protection Program

The following areas are addressed under the SPU Corrosion Protection Program:

- Cathodic protection system updates
- Cooperative testing with other facilities
- Design and installation of new corrosion control systems for new or existing structures
- Repair and maintenance of existing systems
- Routine performance monitoring of existing systems
- Staff training

### 6.2.5 Design Resources

In addition to this chapter, which is a standalone design resource, SPU possesses the following additional resources:

- [Standard Construction Specifications Institute \(CSI\) Specifications. Appendix 6A - CSI Specifications for Cathodic Protection](#) contains standard specifications for cathodic protection in the latest edition of CSI Master Format:
  - Impressed Current Cathodic Protection System 26 42 00
  - Test Stations 26 42 01

Removed for Security

## 6.3 GENERAL REQUIREMENTS

---

The following organizations have developed industry standards for corrosion control:

- The Association for Materials Protection and Performance (AMPP) , the worldwide corrosion authority (formerly known as NACE International [NACE])
- International Standards Organization (ISO)
- American Water Works Association (AWWA)
- Canadian Standards Association (CSA)
- National Electrical Code (NEC)
- Washington State Department of Ecology (Anode Wells)

Regulations pertaining to SPU cathodic protection vary. Water pipelines are not regulated from a corrosion control standpoint. However, concerns for public safety and replacement costs justify cathodic protection.

The Federal Department of Transportation has developed many criteria for protection of steel structures. Federal regulations require that any metallic structure used to transport or house dangerous materials must use some form of external corrosion control. Regulations are described in the Code of Federal Regulations (CFR):

- Natural Gas Pipelines – 49 CFR, Part 192, Subpart I
- Liquefied Natural Gas – 49 CFR, Part 193, Subpart G
- Hazardous Liquids – 49 CFR, Part 195, Subpart D
- Underground Storage Tanks – 40 CFR, Part 280

Many cathodic protection system requirements described in these documents have been carried forward into non-regulated industries, such as water transmission and water distribution piping.

## 6.4 BASIS OF DESIGN

---

For this DSG, basis of design documentation communicates design intent primarily to reviewers and future users of a constructed facility. By documenting the basis of design and archiving it with the project record drawings (as-builts), future staff has access to design decisions.

### 6.4.1 Basis of Design Plan Sheet

The basis of design sheet is a general sheet that shows a plan overview and lists significant design assumptions and requirements for major design elements. The following are SPU standards for this sheet:

- The design engineer must include a basis of design plan sheet in the plan set.
- The sheet must be archived with the record drawings.

The basis of design plan sheet is not intended for construction and should not be included with the bid set. The sheet is inserted after the project has begun. See [DSG Chapter 1, Design Process](#). The design elements that should always be shown for a cathodic protection on a project plan sheet are shown in Figure 6-1.

**Figure 6-1**  
**Basis of Design Plan Sheet Data for Cathodic Protection**

<b>Cathodic Protection</b>
Length of pipe protected: _____
What was problem? Where/why? _____
Existing coating condition/assumptions: _____
Assumed current requirements (amps required; life expectancy; amps consumption rate): _____
Potential profile: _____
Project specific/special information: _____

## 6.4.2 Design Criteria List

For every cathodic protection project, the design engineer should use a design criteria list to develop a basis of design plan sheet. The design criteria list is a shortened version of the most important design requirements (Table 6-1). This information is not intended for construction and should not be included in the bid set. If included with a bid set, the design criteria should be labeled *Informational Only*.

Typically, the design criteria list is completed with the Preliminary Engineering Report as a concise summary. However, the Preliminary Engineering Report can provide a much lengthier description of design requirements.

**Table 6-1**  
**Design Criteria List for Cathodic Protection (Example)**

Criteria	Information on sheet
Length of pipe protected	Measurement in ft
Concern or problem to be resolved	Brief text description
Existing coating condition/assumptions	Percentage, efficiency, etc.
Electrical	
Structure current requirement	Standard table or actual tests
Amps Required	Area x current density
Life expectancy	30 year for impressed current 10 year for anodes
Consumption rate	(life expectancy)
Potential profile	Native (before cathodic protection) ON (after cathodic protection)

Criteria	Information on sheet
	Stray C (after rail transit energized)

### 6.4.3 Types of Systems

Two types of cathodic protection systems are used to control corrosion on external surfaces of buried or submerged structures and internal surfaces of elevated water tanks: *impressed current* and *galvanic anode systems*. The specific application of each is based on:

- Amount of cathodic current necessary to provide effective corrosion control
- Environment in which the structure and cathodic protection system will be used
- Required life of the system

#### 6.4.3.1 Impressed Current

*Impressed current* cathodic protection system uses an external power source (usually a transformer rectifier) to supply protective DC current onto facilities requiring corrosion protection. Impressed current systems typically protect large surface areas such as several miles of transmission mainlines or large blocks of distribution piping. Impressed current systems are also used for the wetted internal surfaces of water storage tanks or on the soil side surfaces of at or below grade storage tanks.

#### 6.4.3.2 Galvanic Anode

*Galvanic anode* cathodic protection systems rely on the electrochemical potential difference between metals to force current from a location of active potential to a location of noble potential. The most common source of a galvanic anode cathodic protection system is an example of a standard battery. When two dissimilar materials are immersed in a common electrolyte and share a common electrical connection, current is forced from the high energy location to the low energy location. Because they have limited driving potential, galvanic anode systems are used where only a limited amount of protective current is needed. Some examples are short spans of well-coated pipeline or the internal surfaces of coated water storage tanks.

## 6.5 HOW TO USE THIS CHAPTER

This chapter of the DSG contains detailed DGs and TPs for cathodic protection of SPU water, and drainage and wastewater infrastructure. In many respects, this chapter is a standalone guide to cathodic protection selection for that infrastructure, which is primarily pipelines and water tanks. Figure 6-2 illustrates how SPU uses the basic information presented in the chapter to select an appropriate cathodic protection method. The method selected will contain more specific instructions for field testing and installation.

**Figure 6-2**  
**SPU Design Process for Cathodic Protection**

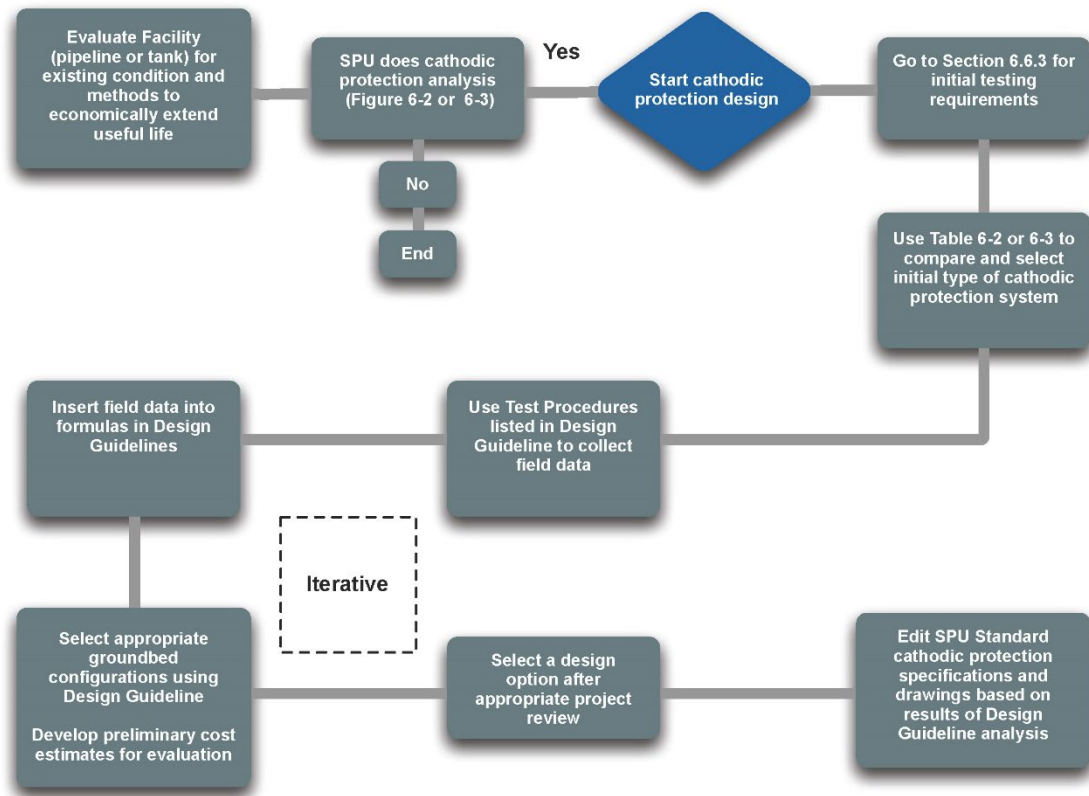

## 6.5.1 SPU Procedure for Selecting Cathodic Protection

The following steps are the SPU procedure for selecting cathodic protection. These steps must be followed in order.<sup>1</sup>

1. Designer reads DSG sections 6.1 through 6.4 to gain a general understanding of existing types of SPU cathodic protection systems.
2. Based on type of structure being installed (pipeline, water tank, or other facility), SPU analyzes the need for a cathodic protection system (DSG section 6.6.1) using established criteria shown on Figure 6-2 and Figure 6-3.
3. **Designer** reviews DSG section 6.6.2 (for selecting TPs) and Table 6-2 and Table 6-3 to understand the type of system (impressed current or galvanic anode) that can be used to protect the structure.

<sup>1</sup> Generally, SPU makes an initial selection of a type of anode system and then goes through the initial design process to see if the selection makes sense for the project. As shown on Figure 6-2, the process is iterative. For purposes of this DSG, the steps below assume a linear procedure.

4. **Designer** reviews DSG section 6.6.3 (for initial testing) to determine which DG (DSG section 6.7) to use for the project.
5. Designer selects a groundbed configuration and then refers to the particular DG for field testing requirements. A brief description of each field test(s) that may be used is included in the DG.
6. **SPU** conducts the appropriate field tests as described in the DG.

**Note:** Not all field tests outlined in a DG are necessary. Removed for Security

7. After the field data have been collected and analyzed, user inserts the appropriate values into the design formulas described within the particular DG.

**Note:** Field testing results and calculations give the design engineer the protective current requirements, groundbed configurations, and rectifier sizing (for impressed current systems). Existing SPU cathodic protection specifications and drawings should then be amended to reflect the requirements of these results. These specifications and drawings are located on the SPU corrosion protection SharePoint website. Two generic specifications (Impressed Current Cathodic Protection System and Test Stations) are available in [Appendix 6A - CSI Specifications for Cathodic Protection](#) of this chapter.

8. Using additional information provided in the DGs, SPU commissions the CP system, makes any adjustments, and performs post-installation testing.

## 6.5.2 Design Issues

Table 6-2 and Table 6-3 can be used, respectively, to help determine the correct DG for a particular effect or issue with the SPU pipeline system or water tank.

**Table 6-2**  
**Cathodic Protection (Impressed Current) Issues Comparison for SPU Pipeline Systems<sup>1</sup>**

Project Effect or Issue	Deep Anode Groundbed	Semi-Deep Anode Groundbed	Distributed/ Point Anode Groundbed	Point Galvanic Anode	Linear Anode Groundbed
Design and constructability issues	Drilling >300 ft If soil resistivity is too high, will not function  Good choice for paved/developed areas	Drilling 50–100 ft	Drilling <30 ft  Costly in paved or developed areas	Drilling <25 ft	Trench depth & Directional  Drilling for retrofit
Disruptive to work area	Low	Low	Med	High	Low, if constructed w/ project
Required current	High	Med	Med-Low	Low	Any

Project Effect or Issue	Deep Anode Groundbed	Semi-Deep Anode Groundbed	Distributed/Point Anode Groundbed	Point Galvanic Anode	Linear Anode Groundbed
Focused protection coverage	No	Yes	Yes	Yes	Yes
Protection area	Broadest	Broad	Narrow	Narrow	Point [n/a]
Design guideline	DG1	DG2	DG3	DG4	DG5

Notes

<sup>1</sup> Assumes a large pipeline project, same coverage amount.

Acronyms and Abbreviations

DG: design guideline

ft: feet

**Table 6-3  
Cathodic Protection Systems Used in SPU Water Tanks**

Effect or Issue	Impressed Current System	Galvanic Anode System
New water tank	Low Current	Low Current
Existing water tank	High Current	Med Current
Focused protection coverage	No	Yes
Protection area	Broad	Broad

## 6.6 DESIGN PROCESS

This section describes the methodology SPU uses to determine the need for cathodic protection. Several factors are considered: cost, location, and type of system. For the SPU process for cathodic protection, see Figure 6-2.

### 6.6.1 Planning the Project

SPU routinely maintains, inspects, and installs service connections on its water system. These operations and maintenance (O&M) activities can bring to light potential corrosion problems. If so, the design engineer may be asked to investigate and conduct a planning study of the localized areas within the water system. This section describes how SPU typically determines whether a water main or water storage tank will require corrosion protection.

When a corrosion issue is identified, a decision may be made to conduct a quick corrosion control analysis. When done at this stage, scope and budget are limited. The data are mainly meant to help develop concepts for corrosion control solutions.

The following are the basic steps in a corrosion control analysis:

1. **Triggers.** This is a brief list of what O&M activity might occur to trigger having a corrosion control expert review a localized system:
  - a. Investigate/repair leaks
  - b. Find corrosive soils

- c. Failure mode for type of pipe is known to be r severe
2. **Identify Corrosion Potential.** When a trigger exists, the corrosion control specialist will research the area. The specialist will perform a few basic field tests to determine if the environment influencing the water system is corrosive in nature.
3. **Investigate.** If the environment is found to be corrosive or likely to have a high potential for corrosion activity, the specialist will perform additional field tests in more than one location. The findings are summarized in a technical memorandum.
4. **Evaluate.** At this point, there should be evidence that corrosion is a likely problem. All potential solutions, including a *do nothing* alternative, are evaluated. A cost/benefit analysis is completed, and the design engineer adds this information with recommendations to the technical memorandum performed in Step 3.
5. **Decision.** The Water Line of Business representative reviews the design engineer's memorandum and presents the findings and recommendations for approval. If approved, the project is funded and a team assembled.

The decision processes for cathodic protection are shown in Figure 6-3 and Figure 6-4.



**Figure 6-3**  
**Cathodic Protection Analysis for Existing Water Tank**

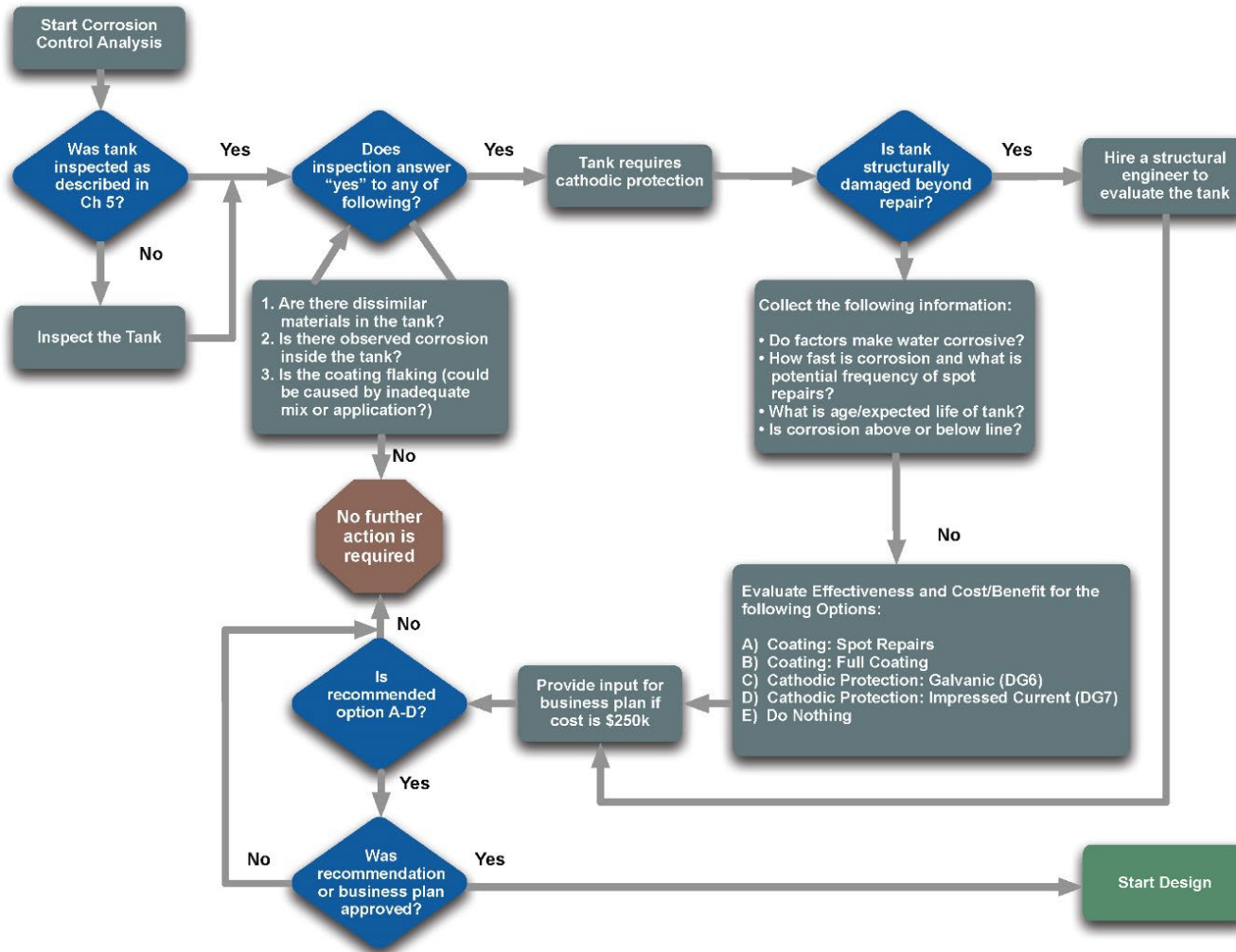

**Figure 6-4**  
**Cathodic Protection Analysis for Existing Pipeline**

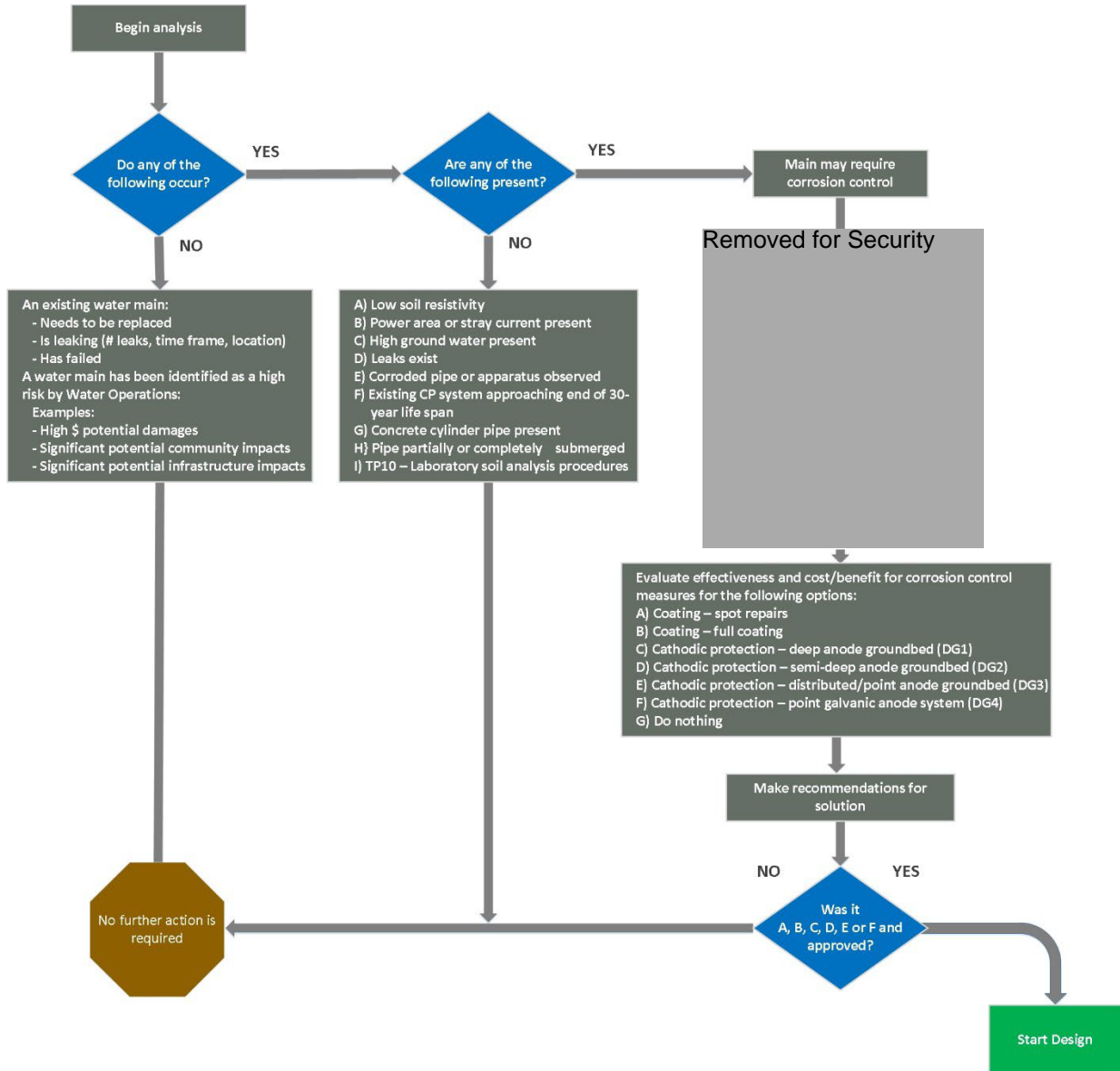

**Acronyms and Abbreviations**

- CP: cathodic protection
- DG: design guideline
- TP: test procedure

## 6.6.2 Selecting Test Procedures

This section describes how to select TPs and the associated DG for a cathodic protection system.

### 6.6.2.1 Water Tanks

Corrosion control analysis of an existing elevated water storage tank requires visually inspecting the interior and exterior surfaces to determine if metal loss is occurring. Additional information gathered during the investigation includes the following:

- Determining if dissimilar metals exist within the tank electrolyte and if the dissimilar components are electrically continuous
- Quantifying coating damage and mode of coating failure
- Evaluating visible corrosion, including locating and determining the severity of surface corrosion and pitting
- Same analysis as shown shall occur for an at grade water tank, with the additions of: conducting field testing of external water tank surfaces and associated buried piping, and historical coating/recoating review.

In general, galvanic anodes will provide adequate current output and distribution to protect the internal submerged surfaces of a water storage tank. Impressed current systems should be reserved for cases where large amounts of bare surface area or dissimilar metals are present.

### 6.6.2.2 Pipelines

SPU transmission water pipeline systems generally require an impressed current cathodic protection system for several reasons:

- Structures are typically several miles long and require more current output to provide the necessary protection.
- Older systems being retrofitted with corrosion control systems have coatings that are generally in poor to failed condition.
- Soil testing is required at most locations to obtain average soil resistivity because imported soils can influence any area. Soil resistivity values tend to be high in north Seattle (less corrosive). In certain areas in southeast Seattle the soil resistivity is low (more corrosive). High resistivity requires higher voltages to provide the correct current distribution.
- Electrical isolation of existing and new pipeline segments is generally not provided. This becomes impossible to correctly determine pipeline to remote earth resistance and characterize coating efficiency, which leads to assumptions when estimating current requirement. Subsequently, design calculations will result in a much larger rectifier than required.

## 6.6.3 Initial Testing

This section outlines initial testing options for SPU water tanks, pipelines, and other facilities that might require cathodic protection.

### 6.6.3.1 Existing Water Tanks

Removed for Security

Removed for Security

The data are

incorporated into the design process using the appropriate DGs:

- DG6 – Water Tank Internal Galvanic Anode System
- DG7 – Water Tank Internal Impressed Current Cathodic Protection System

### 6.6.3.2 New Water Tanks

Cathodic protection of new water storage tanks is generally part of water tank design. From a corrosion control standpoint, it is necessary to determine the surface area to be protected, the type of internal coating to be installed, and any dissimilar metal issues. Water samples must be collected from the water source for the tank to determine resistivity values. DGs for new water storage tanks:

- DG6 – Water Tank Internal Galvanic Anode System
- DG7 – Water Tank Internal Impressed Current Cathodic Protection System

### 6.6.3.3 Existing Transmission Pipelines

Cathodic protection for existing SPU water transmission pipelines will likely incorporate a series of deep or semi-deep anode groundbeds. These system types provide the largest coverage area with minimal right-of-way (ROW) impact. Smaller diameter, short pipelines may use distributed galvanic anodes if easement and ROW property allow.

Most commonly used DGs for existing transmission pipelines:

- DG1 – Deep Anode Groundbed
- DG2 – Semi-Deep Anode Groundbed
- DG3 – Distributed/Point Anode Groundbed

### 6.6.3.4 New Pipelines

New SPU pipeline designs will generally use either deep or semi-deep anode groundbed for corrosion control. Based on pipe diameter and length, the use of distributed (either galvanic or impressed current) may be warranted. Consideration may also be given to the use of linear anodes installed alongside the pipeline. However, linear type anode arrays typically cost more than other systems.

The following are DGs for existing pipelines:

- DG1 – Deep Anode Groundbed
- DG2 – Semi-Deep Anode Groundbed
- DG3 – Distributed/Point Anode Groundbed

### 6.6.3.5 Existing Other Facilities

Other SPU facilities (pump stations, water treatment, gate houses, or reservoirs) may use items such as sheet pile walls, pump stations, lake inlet piping, or other structures that incorporate metallic components. Design requires a significant amount of field testing to determine current demands, power sources, and possible anode groundbed placements; although, SPU typically does not add cathodic protection to these other facilities. The large steel surface areas on these structures require an impressed current system unless high-quality coatings are incorporated to reduce current demand.

The following are DGs for other existing facilities:

- DG1 – Deep Anode Groundbed
- DG2 – Semi-Deep Anode Groundbed
- DG3 – Distributed/Point Anode Groundbed

### 6.6.3.6 New Other Facilities

Cathodic protection analysis should be part of any new SPU facility design. As early as the conceptual design phase, input from corrosion control staff can help determine the most economical method of designing for an extended asset life. Items such as coatings and electrical isolation are often overlooked or not considered until the end of design. Including these considerations in design can significantly reduce costs and improve accuracy.

The following are DGs for existing pipelines:

- DG1 – Deep Anode Groundbed
- DG2 – Semi-Deep Anode Groundbed
- DG3 – Distributes/Point Anode Groundbeds

## 6.6.4 Monitoring

Timely monitoring of cathodic protection systems is an important part of a cathodic protection program. Trained technicians should routinely collect and prepare field data for review by a corrosion control engineer for the following cathodic protection equipment:

- Rectifier output (voltage and amperage) – SPU monitors 4 times a year
- Test stations – annual survey of key test stations (i.e., Sound Transit, Renton, etc.)

Removed for Security

## 6.7 DESIGN GUIDELINES

This section presents 14 DGs that provide specific requirements for cathodic protection system design and standard installation methods. Removed for Security

**Table 6-4**  
**SPU DGs for Cathodic Protection**

Number	Title
DG1	Deep Anode Groundbed
DG2	Semi-Deep Anode Groundbed
DG3	Distributed/Point Anode Groundbed
DG4	Point Galvanic Anode System
DG5	Linear Anodes Groundbed
DG6	Water Tank (Galvanic)
DG7	Water Tank - Impressed Current
DG9	Rectifier Installation/Selection
DG10	Pipe/Casing Test Station
DG11	Joint Bonding
DG12	Interference/Monitoring Test Stations
DG13	Coupon Test Stations
DG14	Linear Galvanic Anode/Grounding Ribbon

**Acronyms and Abbreviations**

DG: design guideline

## 6.7.1 DGI - Deep Anode Groundbed

A deep anode groundbed consists of a single hole 8 to 12 inches in diameter drilled to design depth, which is typically 300 ft or deeper. Anodes installed into the bottom of the drilled hole provide protective current to specific sections of pipeline several miles long, determined by remote earth resistance based on the coating effectiveness. Along with the anode groundbed, this type of system incorporates a transformer rectifier, anode backfill material, anode junction box, means for venting generated gasses, and test stations installed along the pipeline routing.

### 6.7.1.1 Application

Deep anode groundbeds are generally desired where large amounts of protective current are needed. The protective current can be used in a specific location, over a general area or to several miles of buried pipeline (see Table 6-5).

**Table 6-5**  
**Advantages and Disadvantages of Deep Anode Groundbeds**

Advantages	Disadvantages
Can be installed in congested areas or where land acquisition is limited	Higher initial cost than other system types
Provides a lower anode-to-earth resistance path than most other types of installations	Requires the availability of AC power

Advantages	Disadvantages
Reduces instances of stray current interference due to proximity of anodes to foreign structures	Not feasible to replace anodes. The anode wire cannot be repaired if the anode lead wire is broken.
Distributes current better over a larger area as opposed to other system types	Requires additional effort during installation to avoid cross contaminating aquifers or water-bearing zones
Provides a smaller ground footprint, which results in less chance of construction disturbance (e.g., broken header cables and wires)	Difficult to install anodes and requires more inspection oversight
Has less variation in circuit resistance due to seasonal variations such as moisture and freezing	

Acronyms and Abbreviations

AC: alternating current

Removed for Security

### 6.7.1.3 Pre-Design Field Data Collection Requirements

Field data must be collected to understand the quantity of protective current needed and site conditions for locating and designing the appropriate system. Removed for Security

## A. Determination of Area of Desired Influence

Field data collection determines the characteristics of structures that will receive cathodic protection. The amount of protective current necessary for effective corrosion control can be estimated by calculating the surface area of bare steel structure exposed to the electrolyte and applying a coating efficiency factor. To limit the spread of the cathodic protection current, it is necessary to include provisions such as electrical isolation beyond which no cathodic protection would be provided. The cost of installing these devices must be weighed against additional capacity needed for the cathodic protection system.

## B. Location Determination

Location of a deep anode groundbed is based on several factors:

1. **Location and availability of ROW** in which to install the groundbed:
  - a. Groundbeds should not be installed in low-lying areas prone to high surface waters or flooding.
  - b. Avoid areas of known or suspected contamination.
  - c. Areas with previous groundbed information or geological records should be reviewed and incorporated into the final location determination. This information can provide important data: soil strata, ground resistance, and depths to aquifers.
  - d. Avoid drilling a new well next to existing groundbed without site condition analysis as discussed. O&M record can be good resource to research the existing site and improve the new well installation.
2. **Location and availability of commercial power.** Close proximity to AC power will result in a lower installation cost. If power is not readily available, a service drop may be required and additional AC power runs incorporated into the design.
3. **Proximity to protected structure.** It is generally desirable to locate a deep anode groundbed near the center of the area requiring protection and at a **local high point**.
4. **Areas prone to vandalism should be avoided.** Transformer rectifiers use high voltages and serious injury can occur if a unit is broken into or disturbed.
5. **Proximity to foreign structures.** It is possible that the structure to be protected will share a common corridor or be in close proximity to a foreign utility. These include sewer lines or force mains, natural gas piping, and underground AC ducting. A deep anode groundbed location should have as much physical separation from these structures as possible to reduce instances of stray current interference.

## C. Current Requirement Testing

Design and configuration of a deep anode groundbed cathodic protection system is based on the required current output and expected geological condition. It is important to consider all facilities that will be in electrical contact with the cathodic protection system. Total surface area is calculated and a coating efficiency factor applied to



determine the assumed amount of current needed. Removed for Security

#### D. Foreign Structure Influence

The proximity of a deep anode groundbed to nearby foreign structures affects design, routine testing, and operation of the system. Stray current interference results when current is collected and then discharged from a metallic structure that lies in the current path between anode and cathode. Removed for Security

#### E. Soil Resistance Measuring and Soil Resistivity Calculations

Soil resistivity largely determines where an anode groundbed is located and where the anodes are placed within the groundbed. Anode current output is based on the resistance characteristics of the cathodic protection circuit. The largest factor in total circuit resistance is resistance of the anode to remote earth. Removed for Security

#### F. Native State Close Interval Cathodic Protection Survey

A baseline close interval cathodic protection survey for the entire pipeline is a basis for evaluating cathodic protection needs and effectiveness after being energized. Removed for Security

#### G. Native State Survey of Pipeline Test Stations and Coupon Test Stations

Before applying cathodic protection current, all pipeline (metallic structures) and coupon test stations should be measured for native state structure-to-electrolyte potentials. This measurement is used to develop a baseline for future system performance, adjustment and testing. Removed for Security

### 6.7.1.4 Specification and Drawing Development

#### A. Rectifier Sizing

Transformer rectifiers are sized based on the amount of protective current necessary to protect the structure and the resistance of the cathodic protection circuit. The following are steps for sizing the transformer rectifier:

1. Determine protective current required. Removed for Security
2. Calculate soil resistivity at the depth of anode installation. Removed for Security
3. Calculate anode to remote earth resistance using **Dwight's Equation** for single vertical anode resistance to earth:

$$R_{GB} = \frac{.00521 \times \rho}{L} \times \left( \ln \frac{8L}{d} - 1 \right)$$

Where:

$\rho$  = Anode groundbed resistivity, ohm-cm

L = Anode length, ft

d = Diameter of anode, ft

$R_{GB}$  = Resistance of single vertical rod (anode) to earth

4. Calculate resistance of remaining components within the cathodic protection circuit:
  - a. Positive and negative header cable resistances,  $R_{HC}$
  - b. Anode lead wire resistances,  $R_{LW}$
  - c. Structure to earth resistance,  $R_{SE}$
  - d. Resistance of all connections (generally approximated as 10% of items described in a, b, and c),  $R_{CON}$

5. Total circuit resistance ( $R_T$ ) is equal to the summation of all resistances:

$$R_T = R_{GB} + R_{HC} + R_{LW} + R_{SE} + R_{CON}$$

6. Once circuit resistance is known, calculate voltage requirements in accordance with Ohm's law:

$$\text{Volts} = \text{Current} \times \text{Resistance} \quad (V = I_{REQ} \times R_T)$$

7. Use the measured current requirement and calculated voltage requirement to properly size the rectifier.
8. The input power requirements of a transformer rectifier depend on what is available at its location. The rectifier can be specified for a variety of input AC voltages (120V, 208V, 240V, and 480V) and can be either 1- or 3-phase.

### 6.7.1.5 Construction and Equipment Installation Oversight

Inspection of cathodic protection systems requires a person familiar with them. Much of the work follows both electrical and mechanical installation techniques unique to the corrosion industry. Staff who maintain the systems should be used for advice or as field representatives during construction. Removed for Security

### 6.7.1.6 Post-Installation System Checkout and Commissioning

#### A. Rectifier Checkout and Commissioning

Once the transformer rectifier has been wired for AC and positive and negative DC header cables have been installed, the unit requires a functional checkout and commissioning. This important step verifies that the rectifier is operating as required. Removed for Security

#### B. Rectifier Adjustment to Desired Output Levels

After the functional checkout and commissioning of the transformer rectifier, the unit must be adjusted to provide optimum cathodic protection current to the structures. This step must follow the procedure below. That step must follow the procedure below. This procedure ensures that current is provided to the limits of the structure without causing over-voltage damage to the facility near the deep anode groundbed location:

1. Adjust the rectifier to achieve the anticipated current required as determined during field testing activities. Verify that the red line limits of the rectifier are not being exceeded.
2. Measure both the ON and Instant OFF potentials at the test stations nearest the groundbed location. Instant OFF potentials should not be more negative than -1200 millivolts (mV) in reference to CSE.
3. Continue to measure the ON and Instant OFF potentials at test stations increasingly further from the anode groundbed. Compare potential values to the native state potentials measured in DSG section 6.7.1.3G.
4. If potentials measured at the end points of the structure's isolation meet protection criteria, without measuring Instant OFF potentials more negative than -1200mV CSE then initial system adjustment testing is complete. Removed for Security
5. If additional current is needed to provide the correct amount of protective current, adjust the rectifier upwards. Continue testing as required.
6. Perform stray current interference testing. Removed for Security  
Decrease rectifier output if required to alleviate any interference.
7. Allow the system to polarize for at least 30 days. As cathodic protection current is applied to the structure, the measured pipe-to-soil potentials will continue to become more negative, eventually reaching equilibrium.
8. Conduct another test round. Keep in mind that reduction of current output from the rectifier may be warranted.

9. Conduct additional test station data collection within three to six months of system commissioning to verify optimum system performance.
10. Make provisions to allow for ON and Instant OFF close interval survey testing along the pipeline route within one year of system installation.

### C. Testing for Presence of AC Interference

Pipelines paralleling high-voltage electric transmission lines can be subjected to AC interference. Generally, the point of concern occurs at locations where the pipeline and high-voltage lines diverge from one another. Removed for Security

### D. Foreign Line Crossing Stray Current Interference Testing

Stray current interference testing should be conducted in cooperation with other utilities that may be affected by the operation of the newly installed cathodic protection system. Removed for Security

### E. Casing Isolation Testing

Casings are large-diameter piping that house carrier pipeline as it transitions underneath roads or railroad crossings. Proper design and installation of casings electrically isolates the casing from the pipeline. Because the casing is typically a large bare metallic surface area, an electrical short circuit between it and the carrier pipeline results in the casing absorbing most of cathodic protection current. This in turn reduces protection of the pipeline along its route. It also results in the pipeline within the casing not receiving protective current. Removed for Security

## 6.7.2 DG2 - Semi-Deep Anode Groundbed

Semi-deep anode groundbeds are typically used when the amount of protective current necessary is less than that normally supplied by a deep anode groundbed, localized cathodic current but distributed anode system is not suitable for the site. Semi-deep anode cathodic protection systems incorporate a transformer rectifier, anode backfill material, anode junction box, a means for venting generated gasses, and test stations.

### 6.7.2.1 Application

Semi-deep anode groundbeds are generally desired where moderate amounts of protective current are necessary. Typical instances may include pipelines of limited length (generally less than 2 miles of well coated pipeline), , or large concentrated surface areas such as the soil side bottom of aboveground storage tanks. Semi-deep anode groundbeds can be installed in groups or as a single unit. See Table 6-7.

**Table 6-7  
Advantages and Disadvantages of Semi-Deep Anode Groundbeds**

Advantages	Disadvantages
Can be installed in congested areas or where land acquisition is limited	Higher initial cost than other system types due to header cable installation of paralleled wells
Drilling depths are often much shallower than deep anode grounded systems	Design considerations may require that multiple semi-deep anode groundbeds be installed to accommodate current and circuit resistance requirements
Provides a lower anode-to-earth resistance path than other types of installations	Requires the availability of AC power
Reduces instances of stray current interference due to proximity of anodes to foreign structures	Replacement of anodes is difficult. The anode wire cannot be repaired if the anode lead wire is broken
Less variation in circuit resistance due to seasonal variations such as moisture and freezing	Requires additional effort during installation to avoid cross-contaminating aquifers or water-bearing zones
Generally, have a long design life, oftentimes greater than 20 years	Difficult to install anodes and requires more inspection oversight

**Acronyms and Abbreviations**

AC: alternating current

Removed for Security

**6.7.2.3 Pre-Design Field Data Collection Requirements**

**A. Determination of Area of Desired Influence**

Field data collection determines the characteristics of structures that will receive cathodic protection. The amount of protective current necessary for effective corrosion control can be estimated by calculating the surface area of the steel structure that will

be exposed to the electrolyte and applying a coating efficiency factor. To limit the spread of the cathodic protection current, it is necessary to include provisions such as electrical isolation beyond which no cathodic protection would be provided. The cost of installing these devices must be weighed against additional capacity needed for the cathodic protection system.

## B. Location Determination

Location of semi-deep anode groundbeds is based on several factors:

1. **Location and availability of ROW** in which to install the groundbed.
  - a. Groundbeds should not be installed in low-lying areas prone to high surface waters or flooding.
  - b. Avoid areas of known or suspected contamination.
  - c. Areas with previous groundbed information or geological records should be reviewed and incorporated into the final location determination. This information can provide important data such as soil strata, ground resistance, depths to aquifers, and more.
2. **Location and availability of commercial power.** Close proximity to AC power will result in a lower installation cost. If power is not readily available, a service drop may be required and additional AC power runs incorporated into the design.
3. **Proximity to protected structure.** It is generally desirable to locate the anode groundbeds near the center of the area requiring protection.
4. **Areas prone to vandalism should be avoided.** Transformer rectifiers use high voltages. Serious injury can occur if the unit is broken into or otherwise disturbed.
5. **Proximity to foreign structures.** It is possible the structure to be protected will share a common corridor or will reside within close proximity to a foreign utility. Foreign utilities include sewer lines or force main, natural gas piping, underground AC ducting, and similar. It is desirable to have as much physical separation from these structures as possible to reduce instances of stray current interference.

## C. Current Requirement Testing

Design and configuration of a semi-deep anode groundbed cathodic protection system is based on the required current output and expected geologic condition. It is important to consider all facilities that will be in electrical contact with the cathodic protection system. Total surface area is calculated and a coating efficiency factor applied to arrive at the assumed amount of current that will be necessary. Removed for Security

## D. Foreign Structure Influence

More so than for deep anode groundbeds, proximity of the semi-deep anode groundbed to nearby foreign structures significantly affects design, routine testing, and operation of the cathodic protection system. Stray current interference results when current is collected and then discharged from a metallic structure that lies in the current path

between anode and cathode. Removed for Security

### E. Soil Resistance Measuring and Soil Resistivity Calculations

Soil resistivity plays a large part in determining where the anode groundbed is located and anodes placed within the groundbed. Anode current output is based on the resistance characteristics of the cathodic protection circuit. The largest factor of total circuit resistance is the resistance of the anode to remote earth. Removed for Security

### F. Native State Close Interval Cathodic Protection Survey

A baseline close interval cathodic protection survey for the entire pipeline is a basis for evaluating cathodic protection needs and effectiveness after being energized. Removed for Security

### G. Native State Survey of Pipeline Test Stations and Coupon Test Stations

Before applying cathodic protection current, all pipeline (structure) and coupon test stations should be measured for native state structure-to-electrolyte potentials. This measurement is used to develop a baseline for future system adjustment and testing. Removed for Security

## 6.7.2.4 Specification and Drawing Development

### A. Rectifier Sizing

Transformer rectifiers are sized based on the amount of protective current needed to protect the structure and the resistance of the cathodic protection circuit. The following are steps for sizing the transformer rectifier:

1. Determine protective current required ( $I_{REQ}$ ) as described in Removed for Security
2. Calculate soil resistivity at the depth of anode installation. Removed for Security
3. Calculate anode to remote earth resistance using **Sunde's Equation** for multiple vertical anode resistance to earth, assumed more than one semi-deep well:

$$R_{GB} = \left( \frac{.00521 \times \rho}{N \times L} \right) \times \left\{ \ln \left( \frac{8L}{d} \right) - 1 + \frac{2 \times L}{S} \times \ln (0.656 \times N) \right\}$$

Where:

$\rho$  = Soil resistivity, ohm-cm

L = Anode length, ft

d = Diameter of anode, ft

N = Number of anodes

S = Spacing of anode groundbeds, ft

$R_{GB}$  = Resistance of anode to earth

4. If a single semi-deep anode ground is incorporated in the design, use **Dwight's Equation** to calculate anode-to-remote earth resistance of a single vertical anode resistance to earth:

$$R_{GB} = \frac{.00521 \times \rho}{L} \times \left( In \frac{8L}{d} - 1 \right)$$

Where:

$\rho$  = Anode groundbed resistivity, ohm-cm

L = Anode length, ft

d = Diameter of anode, ft

$R_{GB}$  = Resistance of single vertical rod (anode) to earth

5. Calculate resistance of remaining components within the cathodic protection circuit, including:
- Positive and negative header cable resistances,  $R_{HC}$
  - Anode lead wire resistances,  $R_{LW}$
  - Structure to earth resistance,  $R_{SE}$
  - Resistance of all connections (generally approximated as 10% of items described in a, b, and c),  $R_{CON}$
6. Total circuit resistance ( $R_T$ ) is equal to the summation of all resistances:

$$R_T = R_{GB} + R_{HC} + R_{LW} + R_{SE} + R_{CON}$$

7. Once circuit resistance is known, calculate voltage requirements using Ohm's law:

$$\text{Volts} = \text{Current} \times \text{Resistance} \quad (V = I_{REQ} \times R_T)$$

To properly account for the back-voltage created by the potential between the anode groundbed and the structure, add an additional 2V to the calculated voltage requirements.

8. The measured current requirement and calculated voltage requirement are used to properly size the rectifier.
9. The input power requirements of the transformer rectifier depend on what is available at its location. Rectifiers can be specified for a variety of input AC voltages (120V, 208V, 240V, 480V) and can be either 1- or 3-phase.

### 6.7.2.5 Construction and Equipment Installation Oversight

Construction inspection of cathodic protection systems requires a person with technical expertise of cathodic protection design, standards, and requirements. Much of the work follows both electrical and mechanical installation techniques unique to the corrosion industry. The personnel who maintain these systems and designers should be used for advice or as field representatives during construction. Removed for Security



### 6.7.2.6 Post-Installation System Checkout and Commissioning

#### A. Rectifier Checkout and Commissioning

Once the transformer rectifier is wired for AC and positive and negative DC header cables installed, the unit requires a functional checkout and commissioning. This important step verifies the rectifier is operating as required. Removed for Security

#### B. Rectifier Adjustment to Desired Output Levels

After checkout and commissioning, the unit must be adjusted to provide optimum cathodic protection current. That step must follow the procedure below. This procedure ensures that current is provided to the limits of the structure without causing over-voltage damage to the facility near the deep anode groundbed location:

1. Adjust the rectifier to achieve the anticipated current required as determined during field testing activities. Verify that the red line limits of the rectifier are not being exceeded.
2. Measure both the ON and Instant OFF potentials at the test stations nearest the groundbed location. The Instant OFF potentials should not be more negative than -1200mV in reference to a calibrated CSE.
3. Continue to measure the ON and Instant OFF potentials at test stations increasingly further from the anode groundbed. Compare potential values to the native state potentials measured in DSG section 6.7.1.3G.
4. If potentials measured at the far end points of the structure meet criteria in Removed for Security without measuring Instant OFF potentials more negative than -1200mV (CSE), then the initial system adjustment testing is complete.
5. If additional current is needed to provide the correct amount of protective current, adjust the rectifier upwards. Continue testing as required.
6. Perform stray current interference testing described in Removed for Security. Decrease rectifier output if required to alleviate any instances of interference issues.
7. Allow the system to polarize for typically 30 days. As cathodic protection current is applied to the structure, the measured pipe-to-soil potentials will continue to become more negative, eventually coming to an equilibrium point.
8. Conduct another round of testing, keeping in mind that reduction of current output from the rectifier may be warranted.
9. Conduct additional test station data collection within three to six months of system commissioning to verify optimum system performance.
10. Provisions should be made to allow for ON and Instant OFF close interval survey testing along the pipeline route within one year of system installation.

#### C. Testing for Presence of AC Interference

Pipelines paralleling high-voltage electric transmission lines can be subjected to AC interference. Most often the point of concern occurs where the pipeline and high-

voltage electric lines diverge from one another. Removed for Security

#### D. Foreign Line Crossing Stray Current Interference Testing

Stray current interference testing should be conducted in cooperation with other utilities that may be affected by the operation of the cathodic protection system. Re mo

#### E. Casing Isolation Testing

Casings are large-diameter piping that house carrier pipeline as it transitions underneath roads or railroad crossings. Proper design and installation of casings electrically isolates the casing from the pipeline. Because the casing is typically a large bare metallic surface area, any electrical short circuit between it and the carrier pipeline results in the casing absorbing cathodic protection current. This in turn reduces protection of the pipeline along its route. It also results in the pipeline within the casing not receiving protective current. Removed for Security

### 6.7.3 DG3 - Distributed/Point Anode Groundbeds

Distributed anode groundbeds are installed to protect a structure or a part of the structure. Distributed and point impressed current cathodic protection systems involve two types of installation methods. Both systems rely on anodes installed relatively shallowly, many times less than 30 ft deep. Distributed systems involve several anodes that may be installed along the length of the structure to receive protection. Distributed anode groundbeds may be installed in relatively close proximity or at a location electrically remote from the structure. Distributed anode groundbeds generally consist of several anodes installed in parallel with each other. Point anode cathodic protection systems are usually reserved for hot spots. Hot spots are structures with a small surface area requiring protection within a small geographic area or possible interference or stray current locations.

In either the distributed or point anode applications, the cathodic protection systems may be either impressed current or galvanic. Impressed current point systems, however, are rare.

#### 6.7.3.1 Application

Distributed anodes are generally used to provide current water transmission pipelines in unimproved SPU ROW, to large bare soil-side tank bottoms, pumping stations with extensive grounding systems, or bare pipeline casings. Local geology, such as non-conductive bedrock layers, may also require that several shallow distributed anode groundbeds be installed to provide necessary protective current. As conditions dictate, distributed anodes can be installed either vertically or horizontally. This flexibility allows for a wider variety of equipment during installation (drilling rig or backhoe). See Table 6-8.

**Table 6-8  
Advantages and Disadvantages of Distributed/Point Anode Groundbeds**

Advantages	Disadvantages
Shallower groundbeds may not require large drilling equipment	Multiple anode holes increase the risk of contacting an unknown belowground structure due to header cable installation
Several individual anode groundbeds are installed. If a small number of anodes fail, the remainder may provide the necessary current without adding more anode material	System life is generally less than that of a deep or semi-deep anode groundbed configuration
Easier to add or replace anodes to a distributed array as opposed to a deep or semi-deep groundbed	Distributed anode groundbeds require a larger installation area with more civil work and coordination with permitting agencies
Anodes can be installed in a vertical or horizontal configuration	Distributed anode systems typically have a higher circuit resistance (due to mutual anode interference) and higher associated power costs
It is not necessary to provide groundbed gas venting	

Removed for Security

### 6.7.3.3 Pre-Design Field Data Collection Requirements

The design procedure requires a significant amount of data collection. Field data are needed to understand how much protective current may be needed and what existing site conditions may be. Removed for Security

#### A. Determination of Area of Desired Influence

Field data collection determines the characteristics of structures that receive cathodic protection. The amount of protective current necessary for effective cathodic protection can

be estimated by calculating the surface area of steel structure exposed to the electrolyte and applying a coating efficiency factor. To limit the spread of the cathodic protection current, it may be necessary to include provisions such as electrical isolation beyond which no cathodic protection would be provided. The cost of installing these devices must be weighed against the additional capacity needed for the cathodic protection system.

## B. Location Determination

Location of a distributed anode groundbed is based on several factors:

1. Location and availability of ROW in which to install the groundbed.
  - a. Groundbeds should not be installed in low-lying areas prone to high surface water or flooding.
  - b. Avoid areas of known or suspected contamination.
  - c. Areas with previous groundbed information or geological records should be reviewed and incorporated into the final location determination. This information provides key data such as soil strata, ground resistance, and depths to aquifers.
2. **Location and availability of commercial power.** Close proximity to AC power lowers installation cost. If power is not readily available, a service drop may be required and additional AC power runs incorporated into the design.
3. **Proximity to protected structure.** It is generally desirable to locate the distributed anode groundbed near the center of the area requiring protection. Designer should use structure and anode attenuation calculation procedures per AMPP/NACE for a system more than 2000 feet long.
4. **Areas prone to vandalism should be avoided.** Transformer rectifiers use high voltages. Serious injury can occur if the unit is broken into or otherwise disturbed.
5. **Proximity to foreign structures.** It is possible that the structure to be protected will share a common corridor or will reside within close proximity to a foreign utility. These include non-metallic sewer lines or force mains, natural gas piping, or underground AC ducting. It is desirable to locate anode groundbed with as much physical separation from these structures as possible to reduce stray current interference.

## C. Current Requirement Testing

Design and configuration of a distributed or point anode groundbed cathodic protection system is based on the required current output and expected geologic condition. It is important to consider all facilities that will be in electrical contact with the system. Total surface area is calculated and a coating efficiency factor applied to arrive at the assumed amount of current needed. Removed for Security

## D. Foreign Structure Influence

Proximity of the distributed anode groundbed to nearby foreign structures will affect design, routine testing, and operation of the cathodic protection system. Stray current interference results when current is collected and then discharged from a metallic structure that lies in the current path between anode and cathode. Removed for Security

Removed for Security

### E. Soil Resistance Measuring and Soil Resistivity Calculations

Soil resistivity plays a large part in determining where the anode groundbed is located and where anodes are placed within the groundbed. Anode current output is determined based on the resistance characteristics of the cathodic protection circuit. The largest factor of total circuit resistance is the resistance of the anode to remote earth. Removed for Security

### F. Native State Close Interval Cathodic Protection Survey

A baseline close interval cathodic protection survey for the entire pipeline is a basis for evaluating cathodic protection needs and effectiveness after being energized. Removed for Security

### G. Native State Survey of Pipeline Test Stations and Coupon Test Stations

Before applying cathodic protection current, all pipeline (structure) and coupon test stations should be measured for native state structure-to-electrolyte potentials. This measurement is used to develop a baseline for future system adjustment and testing. Removed for Security

## 6.7.3.4 Specification and Drawing Development

### A. Rectifier Sizing

Transformer rectifiers are sized based on the amount of protective current necessary to protect the structure and the resistance of the cathodic protection circuit. The following are steps for sizing the transformer rectifier:

1. Determine protective current required ( $I_{REQ}$ ) as described in Removed for Security
2. Calculate soil resistivity at the depth of anode installation. Removed for Security
3. For vertical anode installation: Calculate anode-to-earth resistance using **Sunde's Equation** for multiple vertical anodes installed in parallel:

$$R_{GB} = \left( \frac{.00521 \times \rho}{N \times L} \right) \times \left\{ \ln \left( \frac{8L}{d} \right) - 1 + \frac{2 \times L}{S} \times \ln (0.656 \times N) \right\}$$

Where:

$\rho$  = Anode groundbed resistivity, ohm-cm

N = Number of vertical anodes in parallel

L = Individual anode length, ft

d = Diameter of anode, ft

S = Anode spacing, ft

$R_{GB}$  = Resistance of anode to earth

**Note:** This calculation is iterative. It may take several estimations to arrive at the optimum number and size of anodes and their relative spacing. The user is well served to develop a spreadsheet program for calculating anode-to-earth resistance based on multiple groundbed configuration scenarios.

4. For horizontal anode installation: Calculate the anode to earth resistance using the following modification to **Dwight's Equation**:

$$R_{GB} = \left( \frac{.00521 \times \rho}{L} \right) \times \left[ \ln (4 \times L^2) + \frac{(4 \times L) \times (S^2 + L^2)^{1/2}}{dS} \right] + \frac{S}{L} - \left( \frac{S^2 + L^2^{1/2}}{L - 1} \right)$$

Where:

$\rho$  = Anode groundbed resistivity, ohm-cm

L = Individual anode length, ft

d = Diameter of anode, ft

S = Twice the depth of the anode, ft

$R_{GB}$  = Resistance of single horizontal anode to earth

5. Calculate resistance of remaining components within the cathodic protection circuit, including:
- Positive and negative header cable resistances,  $R_{HC}$
  - Anode lead wire resistances,  $R_{LW}$
  - Structure to earth resistance,  $R_{SE}$
  - Resistance of all connections (generally approximated as 10% of items described in a, b, and c),  $R_{CON}$
6. Total circuit resistance ( $R_T$ ) is equal to the summation of all resistances:

$$R_T = R_{GB} + R_{HC} + R_{LW} + R_{SE} + R_{CON}$$

7. Once circuit resistance is known, calculate voltage requirements using Ohm's law:

$$\text{Volts} = \text{Current} \times \text{Resistance} \quad (V = I_{REQ} \times R_T)$$

8. The measured current requirement and calculated voltage requirement are used to properly size the rectifier.
9. The input power requirements of the transformer rectifier depend on what is available at its location. The rectifier can be specified for a variety of input AC voltages (120V, 208V, 240V, 460V) and may be either 1- or 3-phase.
10. Construction and Equipment Installation Oversight: Construction inspection of cathodic protection systems requires a person with technical expertise of cathodic protection i design, standards, and requirements. Much of the work follows both electrical and mechanical installation techniques unique to the corrosion industry. The staff who maintain these systems and designers should be used for advice or as field representatives during construction. As inspectors are assigned to these projects, they will receive special training (usually delivered by SPU corrosion staff to become acquainted with the systems.

### 6.7.3.5 Construction and Equipment Installation Oversight

Construction inspection of cathodic protection systems requires a person with technical expertise of cathodic protection design, standards, and requirements. Much of the work follows both electrical and mechanical installation techniques unique to the corrosion industry. The personnel who maintain these systems and designers should be used for advice or as field representatives during construction. As inspectors are assigned to these projects, they will receive special training (usually delivered by SPU corrosion staff) to become acquainted with the systems.

### 6.7.3.6 Post-Installation System Checkout and Commissioning

#### A. Rectifier Checkout and Commissioning

Once the transformer rectifier is wired for AC and positive and negative DC header cables installed, the unit requires a functional checkout and commissioning. This important step verifies the rectifier is operating as required. Removed for Security

#### B. Rectifier Adjustment to Desired Output Levels

After a complete functional checkout and commissioning of the transformer rectifier has been completed, the unit must be adjusted to provide optimum cathodic protection current to the required structures. That step must follow the procedure below. This procedure ensures that current is provided to the limits of the structure without causing over-voltage damage to the facility near the deep anode groundbed location:

1. Adjust the rectifier to achieve the anticipated current required as determined during field testing activities. Verify that the red line limits of the rectifier are not being exceeded.
2. Measure both the ON and Instant OFF potentials at the test stations nearest the groundbed location. The Instant OFF potentials should not be more negative than -1200mV in reference to a calibrated CSE.
3. Continue to measure the ON and Instant OFF potentials at test stations increasingly further from the anode groundbed. Compare potential values to the native state potentials measured in (see DSG section 6.7.2.3G).
4. If potentials measured at the end points of the structure meet criteria in Removed for Security without measuring Instant OFF potentials more negative than -1200mV, then the initial system adjustment testing is complete.
5. If additional current is needed to provide the correct amount of protective current, adjust the rectifier upwards. Continue testing as required.
6. Perform stray current interference testing. Removed for Security  
Decrease rectifier output if required to alleviate interference.
7. Allow the system to polarize for 30 days. As cathodic protection current is applied to the structure, the measured pipe-to-soil potentials will continue to become more negative, eventually coming to an equilibrium point.
8. Conduct another round of testing, keeping in mind that reduction of current output from the rectifier may be warranted.

9. Conduct additional test station data collection within three months of system commissioning to verify optimum system performance.
10. Make provisions to allow for ON and Instant OFF close interval survey testing along the pipeline route within one year of system installation.

### C. Testing for Presence of AC Interference

Pipelines paralleling high-voltage electric transmission lines can be subjected to AC interference. Most often the point of concern occurs where the pipeline and high-voltage electric lines diverge from one another. Removed for Security

### D. Foreign Line Crossing Stray Current Interference Testing

Stray current interference testing should be conducted in cooperation with other utilities that may be affected by the operation of the cathodic protection system. Re mo

### E. Casing Isolation Testing

Casings are large-diameter piping that house carrier pipeline as it transitions underneath roads or railroad crossings. Proper design and installation of casings electrically isolates the casing from the pipeline. Because the casing is typically a large, bare metallic surface area, any electrical short circuit between it and the carrier pipeline results in the casing absorbing cathodic protection current. This in turn reduces protection of the pipeline along its route. It also results in the pipeline within the casing not receiving protective current. Removed for Security

## 6.7.4 DG4 - Point Galvanic Anode

Point galvanic anodes are installed to provide a degree of cathodic protection at specific locations. For example, a pipeline may have an effective impressed current system used for external corrosion control. However, sections of that pipeline within particularly corrosive environments may not be receiving adequate protective current. Upward adjustment of the rectifier output to protect these unprotected areas may result in coating damage or stray currents in locations nearer the groundbed. Often, the solution is to install a small galvanic system in a specific location, isolated small sections of well-coated pipelines, or at grade water tanks where minimal cathodic current is required.

This section describes techniques for determining the amount of protective current required, the calculations for determining the size and quantity of anodes, and installation material.

### 6.7.4.1 Location of Deficiency

Data collected during routine testing procedures (either annual test station surveys or as a result of a close-interval-survey) may indicate that a short portion of a pipeline is not receiving adequate current to meet corrosion control criteria. If rectifier adjustment is not a viable option due to either over-voltages or stray current concerns, then installation of point galvanic anodes would be warranted.



### 6.7.4.2 On-Site Testing

#### A. Soil Resistivity

Soil resistivity will need to be collected at the area of concern. This involves measuring both the soil resistance and calculating the soil resistivity of the layer into which the anodes will be installed. Generally, the depth of anode installation corresponds to the depth of the pipeline. Once soil resistivity is known, anode-to-remote earth resistance can be calculated. Removed for Security

#### B. Current Requirement

To conduct current requirement testing, two connections must be made to the pipeline. The first connection is used in the test current circuit while the second connection is used to measure the pipe to soil potentials. If a pipe connection is not available in the immediate area, wire spools can be used to provide electrical continuity from test stations further away.

1. Using a portable battery source, apply current to a temporary anode in the immediate vicinity of the deficient area. It is important that the temporary anode be situated somewhat close to the area needing protection to obtain an accurate current requirement.
2. Adjust the current output of the temporary cathodic protection system upward until potentials indicate that corrosion control criteria are being met. It is best to conduct this testing while all other current sources affecting the test location are turned off.

Once the amount of current has been determined, a point galvanic anode system can be designed. Removed for Security

### 6.7.4.3 Circuit Design Calculations

Point galvanic anodes can be installed either horizontally or vertically. The installation methodology is based on the equipment available to perform the work and the ROW constraints.

Formulas are presented below for three scenarios:

- Single galvanic anode installed vertically
- Multiple galvanic anodes installed vertically
- Horizontal galvanic anodes

The size and number of anodes to be installed is based on the current requirement and circuit resistance. The optimum scenario is to install a single vertical anode. However, that scenario may not provide the necessary current (due to limited driving voltage and possible high circuit resistance). If a single vertical anode will not suffice, then design must be based on the remaining formulas.

1. For a single vertical anode, calculate anode to earth resistance using **Dwight's Equation**:

$$R_{GB} = \left( \frac{.00521 \times \rho}{L} \right) \times \left( \ln \left[ \frac{8L}{d} \right] - 1 \right)$$

Where:

$\rho$  = Anode groundbed resistivity, ohm-cm

L = Anode length, ft

d = Diameter of anode, ft

$R_{GB}$  = Resistance of single vertical rod (anode) to earth

2. For multiple vertical anode installation: Calculate anode to earth resistance using **Sunde's Equation** for multiple vertical anodes installed in parallel:

$$R_{GB} = \left( \frac{.00521 \times \rho}{N \times L} \right) \times \left\{ \ln \left( \frac{8L}{d} \right) - 1 + \frac{2 \times L}{S} \times \ln (0.656 \times N) \right\}$$

Where:

$\rho$  = Anode groundbed resistivity, ohm-cm

N = Number of vertical anodes in parallel

L = Individual anode length, ft

d = Diameter of anode, ft

S = Anode spacing, ft

$R_{GB}$  = Resistance of anode to earth

**Note:** This calculation is iterative. It may take several estimations to arrive at the optimum number and size of anodes and their relative spacing. The user should develop a spreadsheet program for calculating anode-to-earth resistance based on multiple groundbed configuration scenarios.

3. For horizontal anode installation: Calculate the anode to earth resistance using the following modification to **Dwight's Equation**:

$$R_{GB} = \left( \frac{.00521 \times \rho}{L} \right) \times \left[ \ln (4 \times L^2) + \frac{(4 \times L) \times (S^2 + L^2)^{1/2}}{dS} \right] + \frac{S}{L} - \left( \frac{S^2 + L^2^{1/2}}{L - 1} \right)$$

Where:

$\rho$  = Anode groundbed resistivity, ohm-cm

L = Individual anode length, ft

d = Diameter of anode, ft

S = Twice the depth of the anode, ft

$R_{GB}$  = Resistance of single horizontal anode to earth

4. Calculate resistance of the remaining components within the cathodic protection circuit, including:
- Positive and negative header cable resistances,  $R_{HC}$
  - Anode lead wire resistances,  $R_{LW}$
  - Structure to earth resistance,  $R_{SE}$

- d. Resistance of all connections (generally approximated as 10% of items described in a, b, and c),  $R_{CON}$
- 5. Total circuit resistance ( $R_T$ ) is equal to the summation of all resistances:

$$R_T = R_{GB} + R_{HC} + R_{LW} + R_{SE} + R_{CON}$$

Once the circuit resistance has been calculated, use Ohm’s law ( $V = I \times R$ ) to solve for current output.  $R$  is the calculated circuit resistance.  $V$  is the driving voltage (difference between the potential of the anode and the structure).

If the value obtained for current is less than that determined during the current requirement testing, then two options are available: (1) use an anode with a higher driving voltage (e.g., high-potential magnesium) or (2) add additional anodes to lower the circuit resistance.

#### 6.7.4.4 Installation

Pre-packaged anodes can be installed many ways: trenching, auguring, or vacuum excavation. Installation methodology is based largely on system design and available ROW. It is important when retrofitting or improving cathodic protection to an existing system by installing point anodes, that the installation be completed so that future testing can be properly conducted. This will require that the anode header cables be connected to the pipeline through a dedicated test station with a secondary test station. The station will allow for synchronized interruption of the structure’s cathodic protection system during monitoring.

### 6.7.5 DG5 - Linear Anode Groundbed

Linear groundbeds are those that incorporate a long-line anode installed adjacent to the entire length of the pipeline during construction. Linear anodes can be either impressed current or galvanic. Based on the type of electrolyte surrounding the anode and current requirement demands, it may be necessary to install more than one anode along the pipeline. This case holds true more often for galvanic anodes than for impressed current anodes. See [DG14 – Linear Galvanic Anode/Grounding Ribbon Installation](#).

#### 6.7.5.1 Application

**Table 6-9**  
**Advantages and Disadvantages of Linear Anode Groundbed**

Advantages	Disadvantages
Generally easy to install during pipeline construction	Retrofitting a pipeline with a linear anode system is most often not be economically justifiable
Very good current distribution	Based on current requirement and circuit resistances, multiple anodes may be required along pipeline routing
Provides a long life due to large amount of anode material	Anode string may require multiple header cable taps to limit voltage drop and reduce circuit resistance
Easy to locate and repair breaks in the anode	For long pipeline runs (several miles), cost of linear anode system can be more than other conventional type anode groundbed systems
	Based on length of impressed current anodes, multiple rectifiers may be required

Removed for Security

### **6.7.5.3 Pre-Design Field Data Collection Requirements**

Significant data collection is required for this procedure. Along with system design information, field data are needed to understand the quantity of protective current needed and site conditions.

#### **A. Determination of Area of Desired Influence**

Field data collection determines the characteristics of structures that will receive cathodic protection. The amount of protective current necessary for effective corrosion control can be estimated by calculating the surface area of steel structure that will be exposed to the electrolyte and applying a coating efficiency factor. To limit the spread of the cathodic protection current, it may be necessary to include provisions such as electrical isolation beyond which no cathodic protection would be provided. The cost of installing these devices must be weighed against additional capacity needed for the cathodic protection system.

#### **B. Location Determination**

The linear anode array is located adjacent to the pipeline structure. This type of corrosion control system lends itself well to being completed during the construction of the pipeline.

#### **C. Current Requirement Testing**

Design and configuration of a linear anode groundbed cathodic protection system is based on the required current output and expected geological condition. It is important

to consider all facilities that will be in electrical contact with the cathodic protection system. Total surface area is calculated and a coating efficiency factor applied to arrive at the assumed amount of current needed. Removed for Security

#### **D. Foreign Structure Influence**

The linear anode design is a close-coupled anode system. Interference on other foreign structures because of its operation is rare. The voltage gradients generated by this type of system do not extend far from the location of the anode material. The only area of concern is locations of foreign pipeline crossings. In such cases, it may be necessary to remove the anode at the crossing location or provide for other means that will not cause stray current interference. Methods of controlling possible interference are (1) non-conductive shielding mats installed between the anode and foreign structure, (2) provisions for electrical bonding between the two structures, or (3) installation of grounding cells.

#### **E. Soil Resistance Measuring and Soil Resistivity Calculations**

It will be necessary to collect information about the backfill material that will surround the pipeline and anode system. Typically, soil resistivity information is determined by performing calculations on the in-situ soil environment using the 4-pin Wenner array. For this type of system, the backfill material should be tested using methods such as a soil box or other laboratory means. The exception to this is pipelines backfilled with native material. For native material backfilling, the soil within the pipeline routing can be tested in the field using the 4-pin Wenner array. However, it is important that proper testing procedures be followed. Do not perform the testing near belowground structures. Use the Barnes Layer Analysis to calculate the layer resistivity in which the anode will be placed.

#### **F. Native State Close Interval Cathodic Protection Survey**

A baseline close interval cathodic protection survey for the entire pipeline will provide a basis for evaluating cathodic protection needs and effectiveness after being energized. Removed for Security

#### **G. Native State Survey of Pipeline Test Stations and Coupon Test Stations**

Before applying cathodic protection current, all pipeline (structure) and coupon test stations should be measured for native state structure-to-electrolyte potentials. This measurement is used to develop a baseline for future system adjustment and testing. Removed for Security

### **6.7.5.4 Specification and Drawing Development**

#### **A. Rectifier Sizing – Impressed Current Anode Systems**

Transformer rectifiers are sized based on the amount of protective current necessary to protect the structure and the resistance of the cathodic protection circuit. The following are steps for sizing the transformer rectifier:

1. Determine protective current required as described in Removed for Security

2. Calculate soil resistivity at the depth of anode installation as described in **Removed for**
3. For horizontal anode installation: Calculate the anode to earth resistance using the following modification to **Dwight's Equation**:

$$R_{GB} = \left( \frac{.00521 \times \rho}{L} \right) \times \left[ \ln (4 \times L^2) + \frac{(4 \times L) \times (S^2 + L^2)^{1/2}}{dS} \right] + \frac{S}{L} - \left( \frac{S^2 + L^2^{1/2}}{L - 1} \right)$$

Where:

$\rho$  = Anode groundbed resistivity, ohm-cm

L = Individual anode length, ft

d = Diameter of anode, ft

S = Twice the depth of the anode, ft

$R_{GB}$  = Resistance of single horizontal anode to earth

4. Calculate resistance of remaining components within the cathodic protection circuit, including:
  - a. Positive and negative header cable resistances,  $R_{HC}$
  - b. Anode lead wire resistances,  $R_{LW}$
  - c. Structure to earth resistance,  $R_{SE}$
  - d. Resistance of all connections (generally approximated as 10% of items described in a, b, and c),  $R_{CON}$
5. Total circuit resistance (RT) is equal to the summation of all resistances:

$$R_T = R_{GB} + R_{HC} + R_{LW} + R_{SE} + R_{CON}$$

6. Once circuit resistance is known, calculate voltage requirements in accordance with Ohm's law:

$$\text{Volts} = \text{Current} \times \text{Resistance} \quad (V = I_{REQ} \times R_T)$$

7. The measured current requirement and calculated voltage requirement is used to properly size the rectifier. It is good design practice to allow for additional current throughout the life of the system. As structures age, their coating will deteriorate resulting in additional exposed surface area requiring protection. Additionally, new facilities may be added to the structure that will also benefit from protective current.
8. The input power requirements of the transformer rectifier depend on what is available at its location. The rectifier can be specified for a variety of input AC voltages (120V, 208V, 240V, 480V) and can be either 1- or 3-phase.

### 6.7.5.5 Post-Installation System Checkout and Commissioning

Construction inspection of cathodic protection systems requires a person with technical expertise of cathodic protection design, standards, and requirements. Much of the work follows both electrical and mechanical installation techniques unique to the corrosion industry. The personnel who maintain these systems and designers should be used for advice or as field representatives during construction. As inspectors are assigned to these projects, they will

receive special training (usually delivered by SPU corrosion staff) to become acquainted with the systems.

### A. Rectifier Checkout and Commissioning

Once the transformer rectifier is wired for AC and positive and negative DC header cables installed, the unit requires a functional checkout and commissioning. This important step verifies the rectifier is operating as required. Removed for Security

### B. Rectifier Adjustment to Desired Output Levels

After a complete functional checkout and commissioning of the transformer rectifier has been completed, the unit must be adjusted to provide optimum cathodic protection current to the required structures. That step must follow the procedure below. This procedure ensures that current is provided to the limits of the structure without causing over-voltage damage to the facility near the deep anode grounded location:

1. Adjust the rectifier to achieve the anticipated current required as determined during field testing activities. Verify that the red line limits of the rectifier are not being exceeded.
2. Measure both the ON and Instant OFF potentials at the test stations nearest the grounded location. The Instant OFF potentials should not be more negative than -1200mV in reference to a calibrated CSE.
3. Continue to measure the ON and Instant OFF potentials at test stations increasingly further from the anode grounded. Compare potential values to the native state potentials measured. See DSG section 6.7.1.3G.
4. If potentials measured at the end points of the structure meet criteria for protection as described in Removed for Security without measuring Instant OFF potentials more negative than -1200mV, then the initial system adjustment testing is complete.
5. If additional current is needed to provide the correct amount of protective current, adjust the rectifier upwards. Continue testing as required.
6. Perform stray current interference testing described in Removed for Security. Decrease rectifier output if required to alleviate any instances of interference issues.
7. Allow the system to polarize for several days. As cathodic protection current is applied to the structure, the measured pipe-to-soil potentials will continue to become more negative, eventually coming to an equilibrium point.
8. Conduct another round of testing, keeping in mind that reduction of current output from the rectifier may be warranted.
9. Conduct additional test station data collection within three months of system commissioning to verify optimum system performance.
10. Make provisions to allow for ON and Instant OFF close interval survey testing along the pipeline route within two to five years of system installation.

### C. Testing for Presence of AC Interference

Pipelines paralleling high-voltage electric transmission lines can be subjected to AC interference. Most often the point of concern is locations where the pipeline and high-voltage electric lines diverge from one another. Removed for Security

### D. Foreign Line Crossing Stray Current Interference Testing

Stray current interference testing should be conducted in cooperation with other utilities that may be affected by operation of the cathodic protection system. Removed for Security

### E. Casing Isolation Testing

Casings are large-diameter piping that house carrier pipeline as it transitions underneath roads or railroad crossings. Proper design and installation of casings electrically isolates the casing from the pipeline. Because the casing is typically a large, bare metallic surface area, any electrical short between it and the carrier pipeline results in the casing absorbing cathodic protection current. This in turn reduces protection of the pipeline along its route. It also results in the pipeline within the casing not receiving protective current. Removed for Security

## 6.7.6 DG6 - Water Tank (Galvanic)

Design is straightforward for galvanic anode corrosion control systems for the internal surfaces of a water storage tank. Coating efficiencies, current requirements, and anode consumption rates result in anodes that are depleted in a non-homogeneous fashion, ultimately resulting in circuit resistances that will continually change. Water temperatures and chemical constituents (such as chlorine used for disinfection) result in an electrolyte that is ever changing.

### 6.7.6.1 Design Requirements

The first step is to use on-site field-testing data to determine the amount of protective current required.

#### A. Field Data Collection

1. To begin, obtain a general estimate of the surface areas needing protection. This can be determined using as-built (record) drawings to estimate the quantity of unprotected steel exposed to the water. Multiply the estimated bare surface area times a presumed current density (2mA/ft<sup>2</sup> is a conservative estimate). This will yield an estimated total current requirement for the submerged surfaces of the tank. Repeat this exercise to gain an understanding of the amount of current required. Field testing provides the actual current needed, but having a general idea before the field visit is good practice.
2. Collect native state structure-to-electrolyte information by conducting a potential profile along the steel wall of the tank, Removed for Security  
This should be done at the roof hatch entrance because that location generally contains the most steel that needs protection (e.g., steel ladders, monitoring equipment, and internal landing platforms).



3. Once the native state data has been collected, insert a temporary anode (must be NSF 61 certified) into the tank water, preferably at a location away from the roof hatch or remotely from steel structure/wall tank. Using a portable battery source and current measuring equipment, apply current between the submerged anode and the tank structure. Allow the temporary system to run for a couple of minutes to provide some degree of cathode polarization.

*Note: If the tank has a significant bare metallic surface area, a galvanic anode system likely will not provide the necessary current.*

4. After a brief polarization period, insert a current interrupter into the temporary anode system and allow the current to cycle. It is important that the interrupter be set for a long ON and a short OFF cycle to discourage depolarization of the cathode. Record both ON and Instant OFF (polarized) potentials at the same locations as the native state potential profile data was collected.
5. Using the measured data, determine if either the -100mV polarization or -850mV polarized potential corrosion control criteria has been met. If not, increase the current output of the temporary cathodic protection system and allow the tank to polarize for a couple of minutes. Generally, a well-coated 5MG tank, should take less than 200mA to protect. Keep in mind that the location of the temporary anode in relation to the reference electrode will result in varying potentials. The closer the reference electrode is to the temporary anode, the more negative the ON reading will be. Typically, the temporary anode is not lowered a significant distance into the water, so the large negative ON potentials should become more reasonable as the reference electrode is lowered further into the tank. However, it is important to keep in mind that the polarized potentials (Instant OFF) are the critical numbers used to establish protection criteria.

### 6.7.6.2 System Design

This DG should allow for a conservative amount of galvanic anode material and subsequent protective current output. Because the anodes are connected to a common header cable and routed through an anode junction box that houses a variable resistor, it is also possible to retard the amount of current flow as required. However, it is significantly more involved to install additional anodes to the circuit once the system is operating. As coating ages, more steel is exposed to the electrolyte, resulting in additional protective current needed. With the type of system design described here, the additional protective current is provided by adjustment of a variable resistor, which decreases circuit resistance and increases protective current.

1. Using the current requirement determined during the field testing, apply a safety factor of 25%. Use this value as the basis for current required. For example, if 80mA provided the necessary current, assume 100mA during design. Typically, the current required for this type of system is achievable with only a small number of anodes. However, for proper current distribution, additional anodes will need to be installed. For that reason, it is prudent to connect all anodes to a common header cable and route the header cable through the test station for proper system adjustment and monitoring.

- Once the required current has been calculated, the number and location of anode strings must be determined. This will be a function of the tank dimensions. Smaller tanks may only require a single *ring* of anodes while larger tanks may require two to three rings. The typical galvanic anode design has either ribbon or rod anodes (usually magnesium) lowered into the tank water. Each anode string is installed until it is generally 4 ft to 6 ft from the floor, with the top of the anode at the level of the tank's overflow piping. Each anode may be a continuous string or a series of anodes spliced together. Figure 6-5 shows a single ring of anodes with multiple anodes included on each string.

Generally, a single anode ring can provide proper current output and distribution for well-coated steel tanks up to about 40 ft to 50 ft in diameter. Tank diameters up to about 80 ft require two anode rings, and tanks with diameters up to about 140 ft require three rings. The outer ring of anodes should be placed between 8 ft to 10 ft from the tank wall. Anodes should then be placed circumferentially around the tank, keeping the spacing such that all anodes are providing current for approximately the same amount of surface area. A good starting point is 10 ft of arc length between anodes. The distance between anodes may have to be adjusted so that a consistent spacing is maintained.

**Figure 6-5**  
**Typical Galvanic Anode Water Tank Installation**

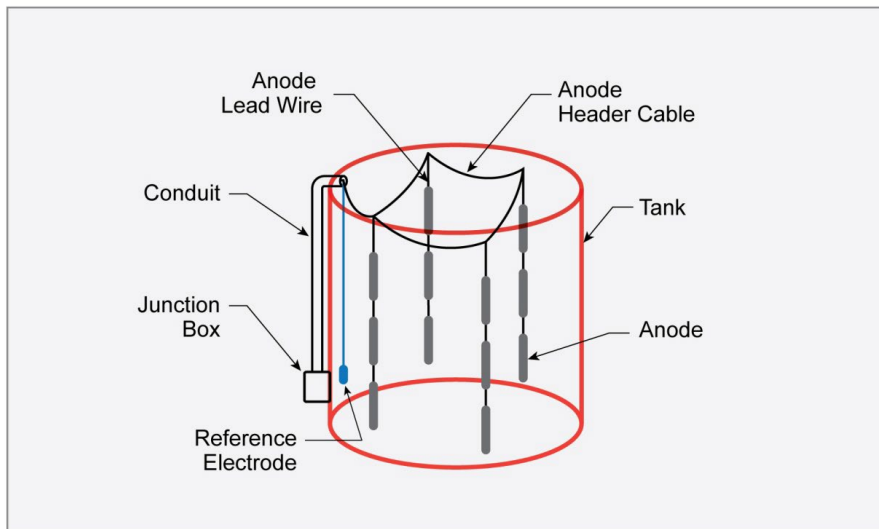

### 6.7.6.3 System Calculations

- Calculate anode to earth resistance using **Sunde's Equation** for multiple vertical anodes installed in parallel:

$$R_{GB} = \left( \frac{.00521 \times \rho}{N \times L} \right) \times \left\{ \ln \left( \frac{8L}{d} \right) - 1 + \frac{2 \times L}{S} \times \ln (0.656 \times N) \right\}$$

Where:

$\rho$  = Anode groundbed resistivity, ohm-cm

$N$  = Number of vertical anodes in parallel

L = Individual anode length, ft

d = Diameter of anode, ft

S = Anode spacing, ft

R<sub>GB</sub> = Resistance of anode to earth

*Note: This calculation is iterative. It may take several educated estimations to arrive at the optimum number and size of anodes and their relative spacing. The user is well served to develop a spreadsheet program that will allow for calculation of anode-to-earth resistance based on multiple grounded configuration scenarios.*

2. Calculate resistance of remaining components within the cathodic protection circuit, including:
  - a. Positive and negative header cable resistances, R<sub>HC</sub>
  - b. Anode lead wire resistances, R<sub>LW</sub>
  - c. Structure to earth resistance, R<sub>SE</sub>
  - d. Resistance of all connections (generally approximated as 10% of items described in a, b, and c), R<sub>CON</sub>

3. Total circuit resistance (R<sub>T</sub>) is equal to the summation of all resistances:

$$R_T = R_{GB} + R_{HC} + R_{LW} + R_{SE} + R_{CON}$$

4. Once circuit resistance is known, calculate voltage requirements in accordance with Ohm's law:

$$\text{Volts} = \text{Current} \times \text{Resistance} \quad (V = I_{REQ} \times R_T)$$

5. Calculate the driving voltage: V<sub>dr</sub> = anode potential – native state potential of the tank steel.
6. If the voltage calculated in step four is less than the driving voltage, then additional anode material must be incorporated into the cathodic protection system design.
7. If the calculated voltage is less than the driving voltage, then the circuit resistance is sufficiently small to allow for adequate current.

*Note: It is a good idea to calculate the circuit resistance once the anodes are half consumed. This consumption will decrease the size of the anode, resulting in an increase in circuit resistance and a decrease in current output. Assuming that the anode diameter has consumed uniformly and anode length has not significantly deteriorated will often satisfy this calculation.*

Calculate the life of the cathodic protection system in the following manner:

1. Calculate the weight of the total anode material (wt = anode length × weight per lineal ft).
2. Determine the efficiency of the anode being used (typically zinc = 90%, efficiency and standard or hi-potential magnesium = 40%).
3. Determine anode utilization factor. This value is essentially how much of the anode is going to be consumed before replacement, typically 85%.

4. Determine the consumption rate of the anode material. Generally, zinc = 23.7 pounds per ampere (amp)-year and magnesium = 17.5 pounds per amp-year.
5.  $\text{Life (years)} = (\text{Anode Weight (pounds [lb])} \times \text{Utilization Factor} \times \text{Anode Efficiency}) / (\text{Anode Consumption Rate (lbs/amp-year)} \times \text{Current Requirement (amps)})$ .
6. Verify that the amount of anode material will satisfy the design life.

#### 6.7.6.4 Anode Junction Box

A properly designed galvanic anode system requires that all anodes be spliced onto a common anode header cable (Figure 6-6). The anode header cable is then routed to the anode junction box where it is connected to the tank through a current measuring shunt and a variable resistor. The anode junction box should also incorporate a test lead connected to the tank and, if installed, a terminal for a stationary reference electrode. An ON/OFF switch can also be installed in series with the anode header cable to facilitate the measuring of instant off potentials.

**Figure 6-6**  
Typical Galvanic Anode Junction Box without On/Off Switch

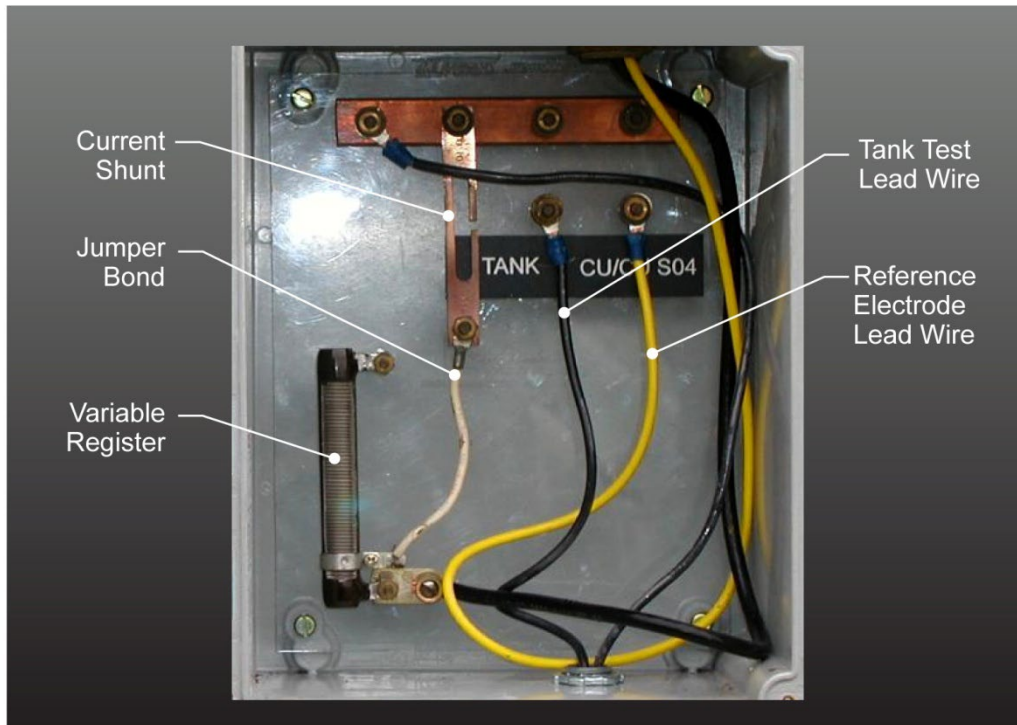

#### 6.7.7 DG7 - Water Tank (Impressed Current)

Impressed current systems for the internal metallic surfaces of water storage tanks incorporate an *autopotential rectifier*. SPU recommends not using either constant voltage or constant current units because they may result in overvoltage at surface locations adjacent to anodes. It is important to note that protectant coatings exposed to high levels of voltage tend to blister and separate from the steel surface, resulting in additional bare metallic surface area to the electrolyte.

The following is a general approach to impressed current system design for the interior surfaces of a water storage tank:

1. Calculate the total surface area to be protected, including the internal area of the riser piping associated with elevated water storage tanks.
2. Estimate the current requirement necessary to provide adequate corrosion control.
3. Calculate the weight of the anode material required to provide the necessary current for the design life of the system.
4. Calculate the position of the anodes (anode locations) that will provide the best current distribution to the wetted surfaces.
5. Calculate the circuit resistance of the system based on the configuration of the anodes, lengths of anode lead wires, length and size of anode and structure header cables, and back voltage associated with the anode material.
6. Complete the sizing requirements for the transformer rectifier.

### 6.7.7.1 Design Requirements

#### A. Surface Area

Calculate the total surface of the submerged portions of the water storage tank. Area calculation is based on the geometry of the tank (cylindrical standpipe or elevated tank with inlet riser are most common) and the level of the water overflow piping. The total wetted surface area does not include areas of the tank above the water line such as the walls and ceiling, areas of vertical support columns above the waterline, or any other structure not in contact with the electrolyte (e.g., ladders and platforms). In addition to the tank walls and flow, be sure to include the area of internal piping, support columns, submerged side wall ladder, inlet piping, and overflow piping to the extent of electrical isolation.

#### B. Current Requirements

The amount of protective current necessary for complete corrosion control is directly proportional to the amount of bare surface area. Typically, a coating efficiency of 95% to 98% is used for estimating the quality of protective coating. For example, a well-coated tank with 1,000 square ft (sq ft) of surface area and a coating efficiency of 98% will require protective current to be delivered to 20 sq ft ( $1,000 \text{ sq ft} \times 2\% = 20 \text{ sq ft}$ ). Given the low consumption rate of impressed current anode materials, a coating efficiency as poor as 20% can be used without resulting in premature anode failure.

Current density required for protection typically ranges between 0.5 and 2.5mA/square ft. When completing impressed current system design for water storage tanks, a conservative value of 2.5mA/sq ft has proven to be a good approach, or per AMPP/NACE recommended current consumption rates for water tanks. This will result in a rectifier sized to meet the increasing current demands of the tank as the internal coating ages.

### C. Anode Weigh Calculation

The weight of anode material necessary to satisfy the design life criteria will be a function of current output and consumption rate of the anode in accordance with **Faraday's Law**:

$$W_t = T \times K \times I \times F_u$$

Where:

$W_t$  = Weight of anode material, pounds

T = Time, years

K = Anode consumption rate (pound per amp-year)

I = Current output, amps

$F_u$  = Assumed anode utilization factor (0.5)

The anode consumption rate (K) depends on the type of anode material being used. Table 6-10 provides K factors based upon anode material.

**Table 6-10**  
**Anode Consumption Rates<sup>1</sup>**

Anode Material	Consumption Rate, K (pounds/amp-year)	Anode Density (pounds/cubic ft)
High silicon cast iron	0.198 – 0.55	445
Platinum	< 0.000004	1340
Platinized niobium (or titanium)	0.00003 – 0.00004	1340
Mixed metal oxide with titanium substrate	0.00002	937

#### Notes

<sup>1</sup> AMPP/NACE Corrosion Engineer's Reference Book, Third Edition

#### Acronyms and Abbreviations

ft: feet

The assumed anode utilization factor,  $F_u$ , is used to account for incomplete anode deterioration, high resistance films that may build up on the surface of the anode, and a factor of safety to accommodate unforeseen circumstances.

### D. Anode Positioning

In circular water tanks, anodes are typically installed in circular arrays to provide optimum uniform current distribution. Information provided by Shepard and Graeser (Corrosion Vol. 6, November 1950 pg.360 – 375) states that the bottom of an anode or anode string should be about as far above the tank bottom as the anode is from the side wall. Additionally, the distance between anodes on the same string should be approximately twice the distance between the tank wall and anode string (Figure 6-7). If more than one anode string is used, the radius of the main anode group should be such that the distance between the tank wall and an anode is approximately one-half of the

distance between anodes. The optimum radius of the main anode array (the outer anode ring) is given by:

$$r = \frac{dN}{2 \times (\pi + N)}$$

Where:

r = radius of the main tank anode array

d = tank diameter

N = assumed number of anodes, select N such that weight/anode is reasonable (applies to high silicon cast iron anodes)

From Shepard and Graeser, the distance between the tank wall and bottom should be about equal, which is about half the circumferential distance between the anodes:

$$S_a = \frac{(2\pi r)}{N}$$

and

$$S_s = \frac{S_a}{2}$$

Where:

S<sub>a</sub> = Circumferential spacing between anodes

r = radius of anode string

N = Assumed number of anodes

S<sub>s</sub> = Anode distance to tank wall and to tank bottom

**Figure 6-7**  
**Anode Positioning**

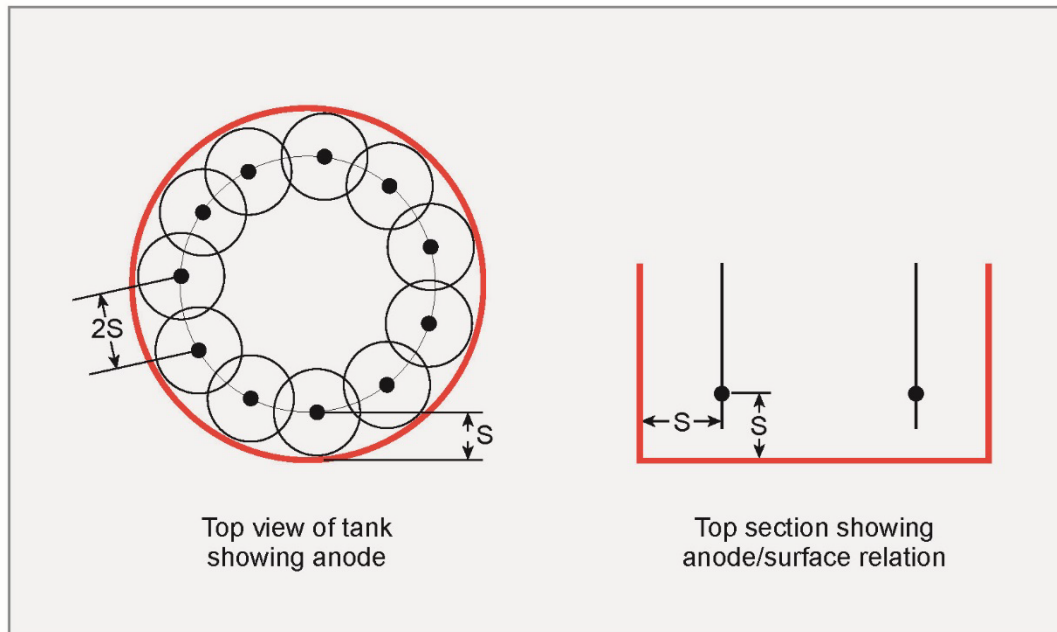

## E. Anode Sizing

Once an appropriate number of anodes is selected, the weight of individual anodes must be determined. The required weight of each anode is simply the total weight required (as calculated in DSG section 6.7.7.1C, then divided by the number of anodes. Generally, the length of platinized niobium or mixed metal oxide wire anodes used in the outer string (the anode array adjacent to the wall) will extend from the calculated distance  $S$  to the top of the water surface level. This simplification of design allows for optimum current density along the large surface area of the wall. The anodes are spaced an appropriate distance apart from each other on the string. The anode dimensions are typically 1 to 2 inches in diameter and 9 to 12 inches long (based on weight of anode material required). Should additional anode rings be required in the tank, the anode material is generally only located at the bottom of the string (to protect the tank floor).

## F. Circuit Resistance Calculation

Total circuit resistance is fundamental to determining the proper size of the transformer rectifier. Generally, the anode lead wires, anode, and structure header cables, cables connections, and structure-to-earth resistances are small compared to the resistance of the anode groundbed. However, good design practice requires calculating this information to ensure proper rectifier sizing:

1. Calculate resistance of anode array,  $R_{GB}$ . Shepard and Graeser estimate calculation of anode to electrolyte resistance for cylindrical anodes in a circular tank:

$$R_{GB} = \frac{0.366\rho}{L} \times \log\left(\frac{d_t}{d_a}\right)$$

Where:

$R$  = anode to tank resistance, ohms

$\rho$  = electrolyte resistivity, ohm-cm

$d_t$  = tank diameter, m

$d_a$  = anode diameter, m

$L$  = length of single anode, m

2. Calculate resistance of remaining components within the cathodic protection circuit, including:
  - a. Positive and negative header cable resistances,  $R_{HC}$
  - b. Anode lead wire resistances,  $R_{LW}$
  - c. Structure to earth resistance,  $R_{SE}$
  - d. Resistance of all connections (generally approximated as 10% of items described in a, b, and c),  $R_{CON}$

Total circuit resistance ( $R_T$ ) is equal to the summation of all resistances:

$$R_T = R_{GB} + R_{HC} + R_{LW} + R_{SE} + R_{CON}$$

Calculation of individual wire resistances can be determined by consulting the wire manufacturer or by referring to the National Electrical Code.



### G. Rectifier Sizing

After determining the circuit resistance and system current requirements, the final step in sizing a transformer rectifier is to calculate the DC voltage requirement. This is done by applying Ohm's law to the known circuit resistance and current requirement plus a voltage factor to compensate for back-voltage.

1. Once circuit resistance is known, calculate voltage requirements in accordance with Ohm's law:

$$\text{Volts} = \text{Current} \times \text{Resistance} \quad (V = I_{REQ} \times R_T)$$

2. Add a 2.0 back-voltage factor (driving voltage between the anodes and carbon steel tank surface) to the calculated voltage requirement.
3. Upsize the voltage by 50% to arrive at a rectifier voltage that will provide ample driving voltage for the life of the system. The 50% increase in voltage requirement is to allow for the rectifier to deliver additional current at the coating ages over time.

### H. Reference Electrode

A stationary reference electrode will need to be installed on the internal surfaces of the water tank to operate the autopotential circuitry of the rectifier. Typically, the reference electrode will be a copper-sulfate variety positioned adjacent to a piece of bare steel (coating holiday) within the tank to provide a worse-case scenario for rectifier operation.

*Note: The life of a typical stationary reference electrode is generally advertised as a minimum of 15 years. However, the stationary reference electrode must be checked each year to ensure it is properly operating.*

## 6.7.8 DG8 - Grid Type (Impressed Current)

At the time of DSG publication, this design guide was not developed as it is not applicable to SPU.

## 6.7.9 DG9 - Rectifier Installation/Selection

Transformer rectifiers, typically called rectifiers, are used to provide power to impressed current anode systems (Figure 6-8). Although rectifier companies carry stock type rectifiers, most units are custom built to a customer's requirements. This guideline describes the most common forms of rectifiers, their input requirements, and special features.

**Figure 6-8**  
**Typical Rectifier Installation**



### 6.7.9.1 Rectifier Types

Each rectifier is unique. It will have differing voltage and amperage requirements based largely on the quantity of protective current desired and the circuit resistance of the cathodic protection system. Each site chosen for an installation has a given supply voltage available that generally dictates the rectifier input voltage. For these reasons, most users of cathodic protection systems do not have a standard (*canned*) rectifier specification. However, several features can be added to any rectifier based on user requirements.

#### A. Constant Voltage Rectifier

This rectifier unit is the most commonly used for cathodic protection. The constant voltage rectifier is a simple unit that typically incorporates a transformer, rectifying element, panel meters, and circuit protection.

The constant voltage rectifier is supplied by incoming AC, generally 120V/240V 1-phase power. Other units are available, which may use 208V, or 480V 3-phase power. The incoming AC requirements will be based upon the power availability at the rectifier location. The incoming AC power is connected to a system stepdown transformer via a main disconnect switch. The secondary side of the transformer is generally configured with 25 adjustable taps used to set the system output to a user determined voltage. This is generally done by manually adjusting tap bars on the rectifier's front panel. Other methods of system adjustment output voltage is done by a rheostat type resistor, adjustment of bonding jumpers, or solid-state telemetry circuit.

Once adjusted, the secondary AC power is routed through a rectifying element that consists of either a selenium stack or silicon diode array. The purpose of the rectifying element is to convert the bi-directional AC power to unidirectional DC power. The DC power exits the rectifying element and choke filter and is routed, through a current measuring shunts, to the positive terminal on the rectifier panel. From the positive terminal, the power is transmitted to the anodes, via an anode header cable, where the current is being discharged off of the anode system through the electrolyte into the

structure being protected. The current then travels from the structure back to its source (rectifier) through the structure header cable, which is landed on the negative terminal located on the rectifier panel.

Adjustment of the DC current output is made by changing the settings on the tap bars. Most rectifiers will have both a *coarse* and a *fine* adjustment setting. This allows for the selection of several differing outputs (generally a minimum of 18 output settings). When adjusting the tap bar settings, the user is changing the secondary voltage, hence the term *constant voltage*. The total DC current output will be based on the voltage setting and the circuit resistance. However, once set, the DC voltage output of the rectifier remains fairly constant. By Ohm's law, this will result in differing current outputs based on circuit resistance. DC current output will change based on the condition of the soil environment surrounding the anode groundbed. Current outputs can change by many percentage points based on the moisture content of the soil. However, the DC voltage of the constant voltage rectifier should remain relatively constant.

### **B. Constant Current Rectifier**

Constant current rectifiers are similar to constant voltage rectifiers with the exception that the current rectifiers provide a constant current output. Internal adjustment of the DC voltage is made automatically based on the cathodic protection circuit resistance. The internal circuitry of a constant current rectifier incorporates a saturable reactor, gate windings, and control windings inserted between the transformer and rectifier stack.

Constant current rectifiers are used in only very specific circumstances. These include when the electrolyte surrounding either the structure or the anodes (but not both at the same time) changes on a regular basis. SPU currently does not have any constant current rectifiers.

### **C. Autopotential Rectifier**

Autopotential rectifiers incorporate circuitry that allows for the adjustment of the DC voltage and amperage to maintain a user-set electrical potential. Autopotential rectifiers are generally used in the cases of cathodic protection installed for dynamic stray currents such as light rail alignments, various cathodic interference by foreign systems, the interior surfaces of water storage tanks, or pier/wharf structures located in tidal areas. Autopotential rectifiers use a stationary reference electrode to monitor electrical potential. When the potential drops below the user specified value, current output is increased to meet criteria.

The requirement for varying system output results from the change in surface area to be protected. For light rail alignments, the pipeline potentials are depressed when a train facility is in service mode and/or train passes by, resulting in the rectifier to automatically increase the cathodic current to protect the pipelines against the stray current impacts. For water tanks and piers or wharves, the surface area exposed to the electrolyte regularly changes (as the level of water increases or decreases or as the tides move in and out). The current must be adjusted because of the potential damage from over-voltage or over-current when water levels are low and less structure is exposed to

the electrolyte. Autopotential rectifiers can be manually operated, allowing them to operate like a constant current rectifier.

#### **D. Rectifier Equipment**

Rectifiers are supplied with standard equipment: transformers, rectifying elements, circuit breakers, and output meters. However, other devices can be installed within the rectifier. Descriptions of some of the rectifier standard equipment and options are described below.

#### **E. Rectifier Cabinet/Mounting**

The rectifier cabinet is typically constructed of coated steel, hot-dipped galvanized steel, or aluminum. Generally, coated steel units are installed indoors and galvanized units are mounted outside. The rectifier cabinets can have a user specified NEMA rating based on where the unit is installed and what type of weather it will be exposed to. Rectifiers are supplied with provisions for floor (pad) or wall (pole) mounting. The doors of the rectifier cabinet should be easily opened exposing the internal components for routine internal inspection and cleaning.

#### **F. Circuit Breaker/Overvoltage Protection**

Incoming AC power is routed through a magnetic or thermal circuit breaker. The circuit breaker allows for inspection and routine maintenance of the rectifier's internal components without presenting a shock hazard. The circuit breaker will be mounted on the rectifier panel and will consist of an ON/OFF switch along with provisions for measuring AC voltage on both sides of the circuit breaker.

The rectifier's overvoltage protection is a fuse installed either on the secondary side of the transformer or in the DC output circuitry. Some units are installed with both types, based on customer requirements. The fuses can either be one-time or reset type.

#### **G. Transformer**

The transformer's function is to either step-up or step-down incoming AC voltage. Typically, a rectifier is installed with a step-down transformer. The transformer uses two independent wire coils wrapped around a common iron core. Incoming AC power from the primary side of the transformer creates an alternating magnetic field around the iron core, which is induced onto the secondary windings. The secondary AC power generated is a function of the incoming AC power and the ratio of transformer windings between the primary and secondary side.

Transformers typically operate trouble free for the life of the rectifier. However, incoming power surges may damage the transformer windings resulting in an inoperable tap setting or shorting of the entire transformer unit. When transformer units no longer function properly, replacement of the transformer unit (as opposed to repair) is most cost-effective.

#### **H. Rectifying Element**

Most rectifying elements consist of either a selenium stack or silicon wafer diode. The purpose of the rectifying element is to convert the incoming AC power into DC. This is

done by allowing AC current to flow in one direction only. This rectified AC is then used to power the impressed current anode groundbed.

Silicon diodes consist of a wafer from a pure single crystal of silicon that is hermetically sealed within a metallic case that has a threaded connection for power transmission. Silicon diodes require a heat sink and are sensitive to input surges. When silicon diodes fail, they fail completely, but are easily replaced.

Selenium stacks have been used longer than the silicon diode. Generally, selenium stacks are bulkier but provide their own heat sink. Selenium can withstand significant voltage surges (up to 10 times their rating) for short periods. Selenium stacks are also slow to fail. The selenium coated onto the stacks requires special disposal because it is a heavy metal. However, the selenium stack is old and phasing out in technology with the current silicon stack; SPU shall avoid using selenium stacks.

### I. Rectifier Meters

Most rectifiers are equipped with both a DC voltage and DC amperage analog meter. Some units may incorporate a single meter that functions as both the voltmeter and ammeter. Some units may incorporate digital meters. The accuracy of the voltage and amperage meters is based on the meter scale and output of the rectifier unit. Some users prefer rectifiers without output meters and rely on staff technicians to record data using portable calibrated equipment. An hour meter is one option. The purpose of the hour meter is to verify that the unit has been operational between routine monitoring.

### J. Optional Equipment

The following optional equipment can be incorporated into construction of rectifier units:

1. **Filters.** Efficiency filters are used to reduce the AC ripple of the DC output. This will increase operating efficiency and decrease operating costs. Choke filter is recommended as a minimum installation.
2. **Surge Protection.** Surge protection is recommended and used to provide protection against lightning strikes and incoming power surges.
3. **Interruptioners.** Rectifiers can be installed within the rectifier circuitry for cycled operation of the unit during testing procedures. The interruptioners are used for cycling the particular rectifier they are installed in and are not configured to operate in a synchronized sequence with other units.
4. **Warning Devices.** Warning devices such as lights can be installed to alert the owner that pre-set conditions (voltage or amperage) have fallen outside of their limitations. SPU does not currently utilize warning devices.
5. **Remote Monitoring.** Specialized remote monitoring units are available that provide real-time data and communication between the rectifier and a user off site. SPU does not currently utilize remote monitoring.
6. **115V AC Convenience Outlet.** A power outlet can easily be installed on the panel of the rectifier. This feature is very useful as a power source when operating interruptioners in sync or when other 115V AC tools are used.

### 6.7.10 DG10 - Pipe/Casing Test Station

Pipeline casings are typically installed underneath major roadways, foreign pipeline crossing, and/or railroad tracks for various benefits to cathodic system and maintenance. The design of test stations to be installed at cased pipelines is straightforward. It is important that two test leads be installed on the carrier pipe and two on the casing at each end. The test leads should be color coordinated to allow easy identification.

Many pipeline casings have a vent installed on at least one end (Figure 6-9). Typically, the vents (which are often not required) are steel and welded to either the top or the bottom of the casing. If constructed of steel and welded to a belowground casing, the vent pipes can take the place of the test leads connected to the casing, if none are available.

**Figure 6-9**  
Typical Pipeline/Casing Installation (Test stations can be installed on both ends as needed)

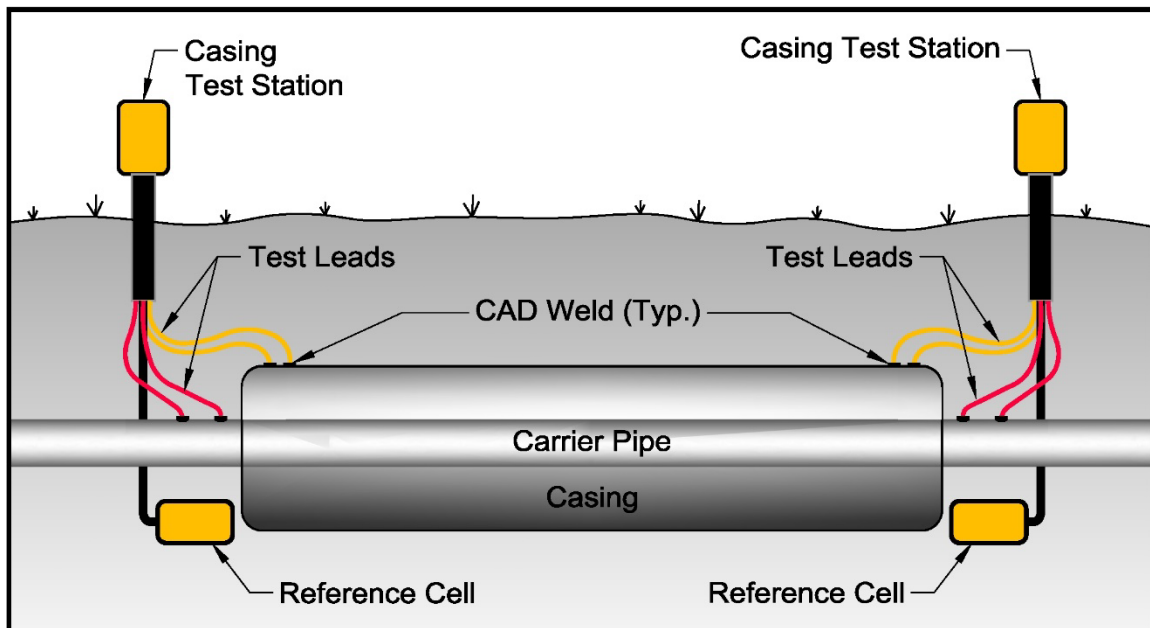

As shown on the figure, a reference electrode is installed near where the carrier pipe exits the casing. This stationary reference electrode provides useful information during routine monitoring and a stable reference during pipeline/casing tests.

The test station must have ample room to accommodate all test leads (Figure 6-10). It is important that the test leads be color coordinated to ensure that the proper connections are made during testing. A schematic of the connections can be included within the test station or drawn on the inside cover of the test station with a permanent marker.

**Figure 6-10**  
**Typical Test Station for Pipeline/Casing Testing**

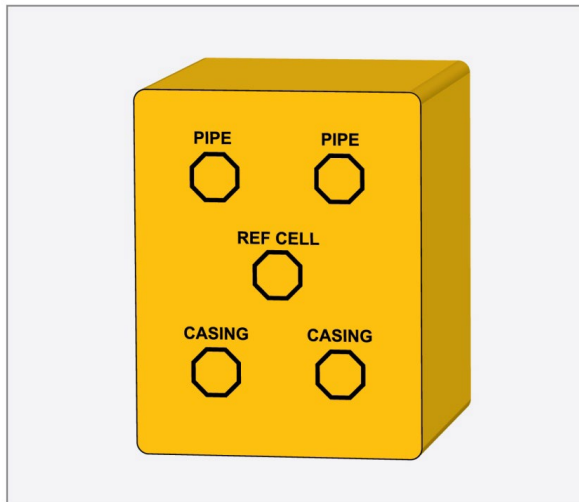

## 6.7.11 DGII – Joint Bonding

Joint bonding is often required to ensure electrical continuity across a mechanical or push-on fitting. In corrosion control, electrical continuity is often required to ensure protective current to all system components. In addition, proper electrical bonding will alleviate stray current interference across joints that are not electrically continuous. Utilizing mechanical connection as an electrical current path shall never be allowed in cathodic protection system.

Joint bonds will normally consist of a length of electrical jumper (cable) that is securely connected to the desired metallic components of a circuit. In many instances, redundant bonds will be installed to meet project-specific requirements for low-resistance bonding or to provide a fully backup should one of the joint bonds fail. Once the electrical connection is made and tested for proper operation, the exposed metallic portions of the connection are coated to maintain the coating integrity of pipeline, which protects against instances of galvanic corrosion occurring between the structure and the bond connection.

### 6.7.11.1 Typical Joint Bond Installation Locations

Joint bonds are typically installed at mechanical connections or wherever a sound metallic connection cannot be ensured. For welded steel structures, the weld beads between pipe sections provide ample current carrying capacity for the cathodic protection current. However, for structures such as bell and spigot pipelines, an adequate electrical connection cannot be guaranteed between the joint connections. This is generally due to a non-conductive rubber gasket that is installed between the joints to create a liquid-tight seal.

Figure 6-11 shows a typical installation of a concrete cylinder pipe. Note the installation of the round rubber gasket (component G in the figure). This non-conductive material will prevent the dedicated flow of cathodic protection current across this joint. It is possible for the steel components of each side of the joint to come into contact with each other. However, this unintentional connection cannot be relied on to provide a dedicated electrical path for continuous current flow.

**Figure 6-11**  
**Typical Concrete Cylinder Pipe Installation**

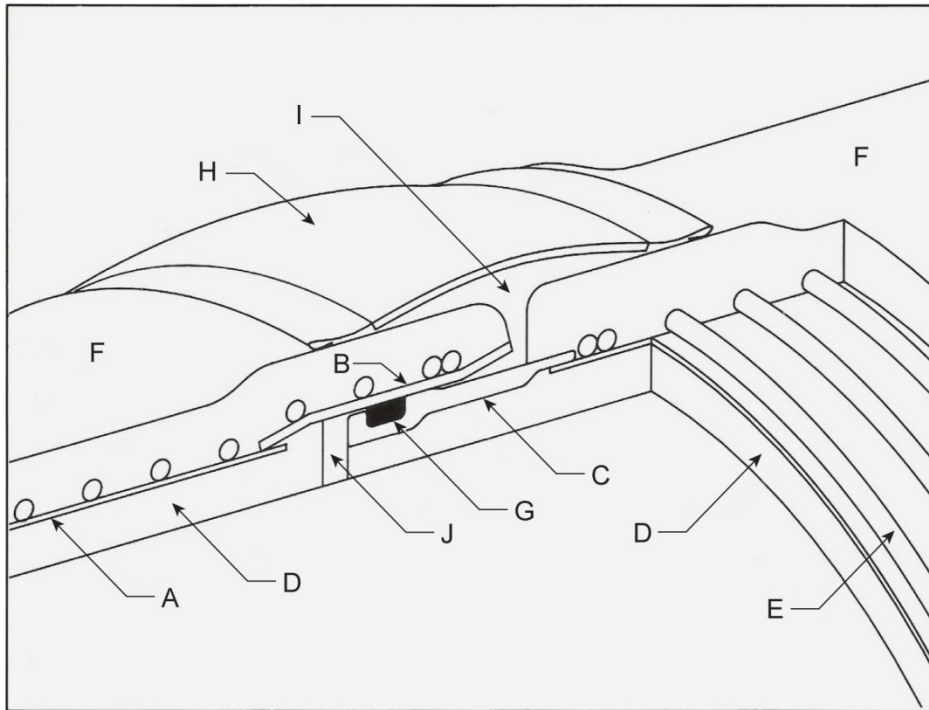

**Components of Installed Concrete Cylinder Pipe.** A steel cylinder (A) with steel bell and spigot joint rings (B) and (C) welded at the ends is lined with centrifugally-cast cement mortar (D). A continuous mild-steel bar (E) is helically wrapped around the cylinder and secured by welding to the joint rings at each end. A dense cement-mortar coating (F) encases the cylinder and bar reinforcement.

A round rubber gasket (G) is placed in an annular groove in the spigot ring just prior to field assembly. A grout band (H) wrapped around the joint and firmly strapped on both sides after field assembly serves as a mold for cement-mortar grout (I) poured in the exterior joint space. The interior joint space is pointed with cement mortar (J).

To allow passage of electrical current from one side of the connection to the other, a dedicated bond connection is typically installed across this type of joint. The bond may be a copper conductor or a welded steel rod.

Locations where joint bonding will generally be required include:

- Ductile or cast iron joints
- Concrete cylinder pipeline joints
- Pipe flanges and valves
- Steel pipelines with bell and spigot type joint connections
- Other pipeline fitting such as fire hydrants, tees, mechanical restraints, and valves

### 6.7.11.2 Methods of Joint Bonding

#### A. Exothermic Weld

The most common form of installing joint bonds for SPU is the exothermic welding process. This connection method incorporates a copper bond cable, graphite mold, charge powder, and an ignition source. The copper bond cable is fed into the graphite



mold, through an appropriately sized hole located at the bottom of the mold. A charge powder is then loaded into the mold where it is ignited. Once ignited, the charge becomes molten hot, flows down onto the copper cable within the mold cavity, and 'welds' the copper cable onto the metallic structure. Figure 6-12 shows a typical weld mold and basic instructions for completing the connection.

**Figure 6-12**  
**Typical Weld Mold with Instructions**

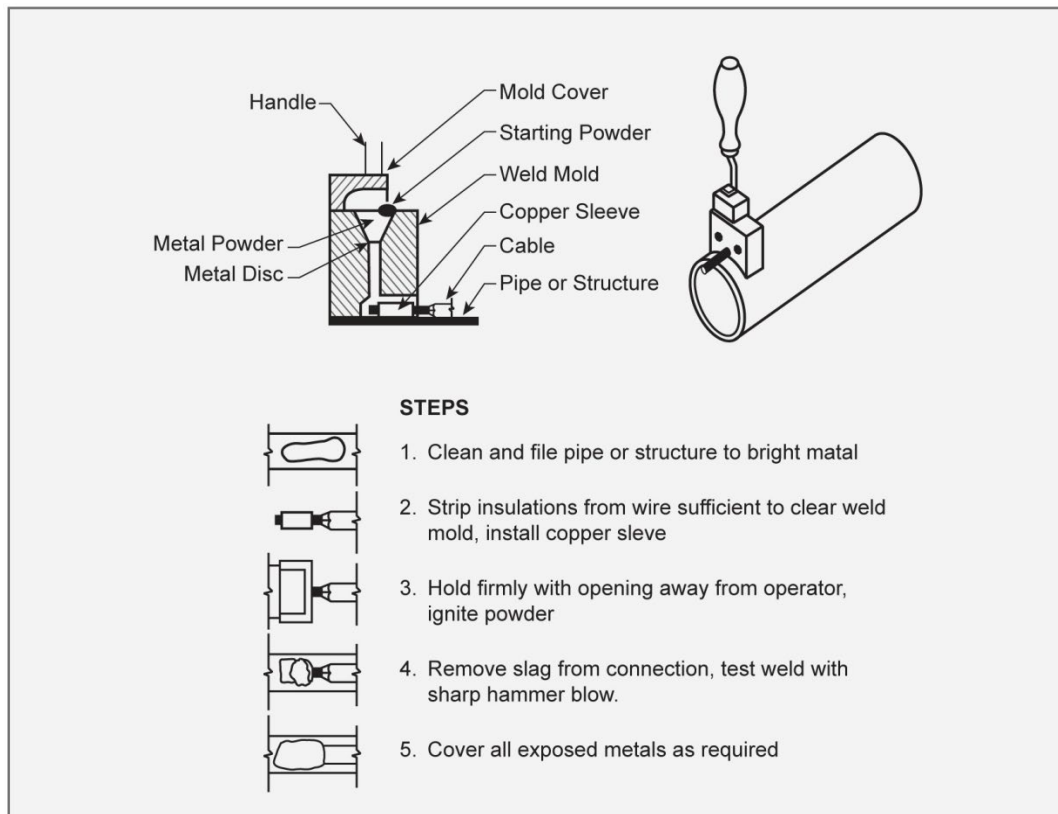

When completing an exothermic weld, it is of utmost importance that the user be extremely cautious because the process generates significant heat and residual smoke. It is also important that the surfaces of the structure and the weld mold itself be dry and free from coating to ensure a sound weld.

## B. Pin Brazing

Another method of installing jumper bond connections is pin brazing. This connection method is similar to exothermic welding in that heat is used to weld a lug to the structure. The cable is then fastened to the lug and properly coated. A portable battery is used to provide the energy necessary to melt the lug connection onto the structure. The advantage of a pin brazing system is that it generates less heat than a typical thermite weld, resulting in less coating damage at the connection location.

### C. Welded Steel Rod

A third method of providing for electrical continuity across a joint involves welding a mild steel rod across the bell and spigot connection. This bonding method is most commonly used for concrete cylinder pipelines (CCP). The steel can of a CCP pipe is surrounded by concrete, which must be chipped away before the steel rod can be installed. The welded steel rod option offers the advantage of being able to properly repair the exposed joint once the weld is made. Copper jumper bonds are bulkier and do not readily lend themselves to proper coating after installation.

#### 6.7.11.3 Post-Installation Testing

There are two methods most commonly used to test the integrity of the connection once it has been made. The first involves striking the connection at a 45° angle with a standard claw hammer. The connection should be struck multiple times with a sharp blow. If the connection is sound, there will be not physical damage or loosening of the cable from the structure.

The second method involves using a micro-ohm meter to measure the electrical resistance across the bonded connection. This TP requires the use of a specialized low resistance equipment with the capability of measuring resistances in the micro-ohm range. The test meter passes a known current between two outer pins, one on each side of the joint, and measures the change in electrical potential between two inner pins situated on each side of the bonded joint. The measured resistance is compared to the theoretical resistance of the bond cable(s) and an acceptable connection is typically demonstrated if the measured resistance is less than 10% of the theoretical resistance.

#### 6.7.11.4 Joint Bonding – Cautions

When completing a joint bond connection, the following precautions must be taken:

1. Ensure that the thickness of metal being welded is adequate for the heat that will be applied. The use of an ultrasonic thickness tester is one method of determining the remaining wall thickness prior to installation of the bond.
2. Only use properly sized charges and correct weld molds as described by the thermite weld manufacturer. The amount of weld powder used for the thermite welding is based on the size of the copper cable and the diameter, orientation, and make-up of the pipe material (ductile iron versus carbon steel).
3. Do not install thermite welds on pressurized vessels or structures containing explosive fumes unless specific manufacturer-generated guidelines are followed.
4. Ensure that the surfaces to be welded on are clean (including removal of the coating down to bare steel) and dry. Using a handheld propane torch is a good method of drying out the surface of the structure. It is also good practice to pre-heat the weld mold before the first charge.
5. Test the bond to verify a sound connection.
6. Properly coat the connection as required.

### 6.7.12 DG12 - Interference/Monitoring Test Stations

The design of interference test stations should incorporate provisions for monitoring potentials and allowing for drainage of possible stray current. In addition, equipment within the

interference test station can include provisions for bonding foreign structures that allow the direction and magnitude of stray current to be determined and eliminated.

The following list of components in an interference test station allow for monitoring and controlling all possible stray current contingencies.

1. **Test Station.** The test station should consist of a post-mounted fiberglass or stainless-steel junction box with ample room for the installed equipment. A schematic of the installation should be housed within the test station or drawn with permanent marker on the interior test station door.
2. **Current Carrying Conductors.** A single #6 current carrying conductor attached to each pipeline and terminated within the test station.
3. **Test Leads.** Two #10 test leads attached to each pipeline and terminated within the test station.
4. **Stationary Reference Electrode.** A stationary reference electrode installed at the pipeline crossing to monitor cathodic protection potentials.
5. **Current Drain Anodes.** Two 17-lb prepackaged magnesium anodes (2 inches in diameter by 5 ft in length) used to drain stray current. Other anode sizes can be used. However, anodes with lower resistance to earth provide better stray current discharge and provide better protection to the pipeline. Additionally, these anodes can be used to provide additional cathodic protection at this location as required.
6. **Variable Resistor.** A variable resistor bonded between both structures will allow for draining of stray current.
7. **Current Measuring Shunt.** A current carrying shunt installed in series with the variable resistor will be used to determine direction and magnitude of current flow.

The test station is shown in Figure 6-13, Figure 6-14, and Figure 6-15.

**Figure 6-13**  
**Sample Interference Test Station Schematic (SPU currently does not have any Interference Test Stations)**

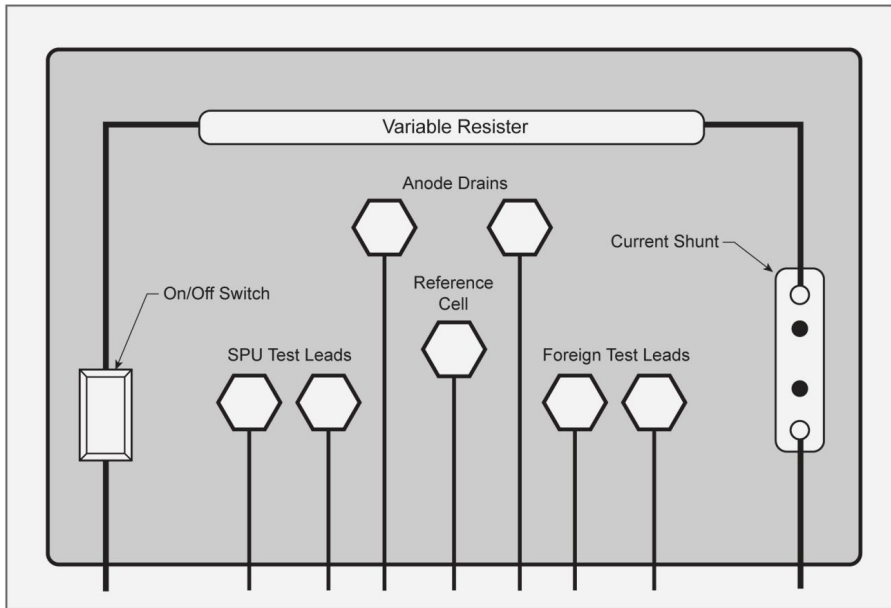

**Figure 6-14**  
**General Schematic of Foreign Line Crossing – Side View**

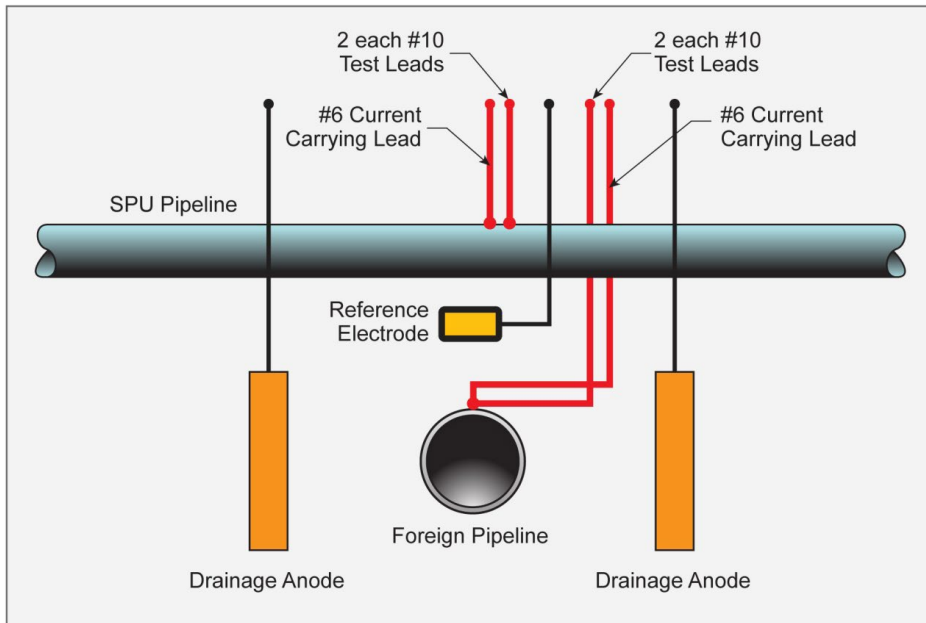

**Figure 6-15**  
**General Schematic of Foreign Line Crossing – Top View**

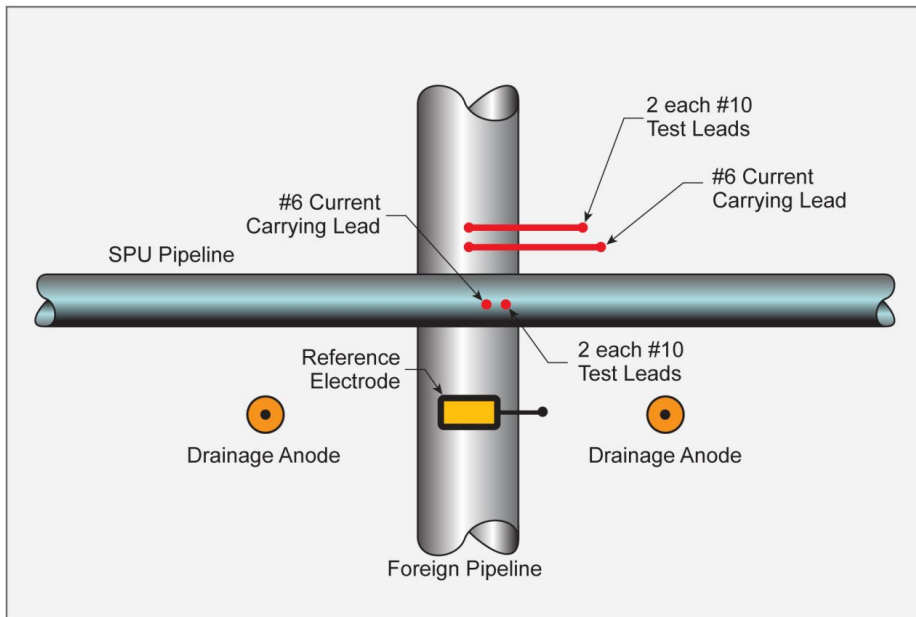

### 6.7.13 DG13 - Coupon Test Stations

Cathodic protection coupons are specialized equipment used to estimate the electrical potential of a submerged or buried structure and to determine the protective current density for a given exposed metallic area (Figure 6-16). Coupons are constructed of the same material as the structure they are intended to represent. They are connected to the structure through a test station. There are several varieties of commercially available coupons. Manufacturers construct coupons to a customer's specifications.

**Figure 6-16**  
Coupons and Test Station

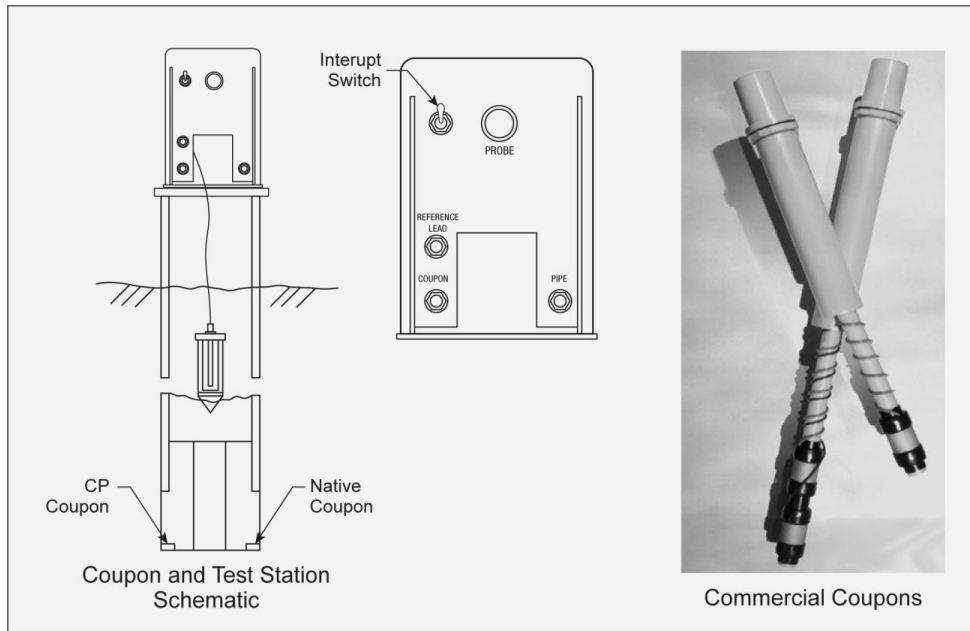

#### Acronyms and Abbreviations

CP: cathodic protection

The advantage of coupons is that they can be installed in many configurations and can provide useful information on the effects of nearby cathodic protection systems. When recording potentials on a pipeline, it is considered standard engineering practice to minimize measurement errors. This requires that error due to current flow be considered. Such consideration is often taken in the form of Instant OFF readings. Unfortunately, many pipelines have directly connected current sources (galvanic anodes) or circumstances that do not allow for simultaneous interruption (or disconnection) of all current sources affecting the testing location. With coupons connected to the structure through a test station, cathodic protection current will be afforded to the coupon. Switching inside the test station will allow for removing the coupon from the cathodic protection circuit and subsequent Instant OFF reading of the coupon. This information used in conjunction with other testing outlined below and sound engineering judgment can yield valuable information about the effects of cathodic protection on the structure itself.

The type, design configuration, installation location, installation method, and monitoring techniques of cathodic protection coupons vary widely. While coupons are not designed to yield specific information about the surfaces of the structure, they are useful in determining direction of current flow, polarization characteristics, and current density information.

SPU does not recommend using coupons as the sole method of verifying the adequacy of a corrosion control system. However, their use in conjunction with other testing techniques will provide the operator with additional data concerning the operation of their corrosion control system. Refer to AMPP/NACE RP0104-2004 The Use of Coupons for Cathodic Protection Monitoring Applications for help in developing a uniform strategy for use of coupons.

### 6.7.13.1 Design of Coupons

The following are desirable design characteristics of coupons:

1. Metallic element manufactured of the same material as the structure to which it will be connected.
2. Metallic surface area representative of the largest expected coating holiday on the structure. This is often difficult information to acquire. Most coupon manufacturers provide coupons with 1.0, 10, or 100 square centimeters of surface area. SPU standard for all coupons is 10 square centimeters.
3. Two test lead wires connected to the coupon. Because one of the wires will be used in the cathodic protection circuit, the wire gauge must be large enough to minimize resistance. No. 10 or No 12 AWG sizes will normally suffice.
4. Two coupons with wires to reference to test station. Some coupon assemblies incorporate two coupons within their test stations. One coupon will be connected to the structure while the other coupon (native or free corroding coupon) will remain disconnected from structure to provide reference data.
5. Coupons should incorporate a means to read them that minimizes measurement error. They should offer the ability to take a reading with a reference electrode in close proximity to the reference electrode. Many coupons include a stationary reference electrode attached directly to them with a lead wire routed to the test station. Other coupon assemblies use a dip tube. This tube allows access to the coupon by placing a portable reference electrode down a non-metallic tube to a location near the coupon.
6. An ON/OFF switch installed within the coupon test station. This will allow for the measurement of both the ON and Instant OFF potential of the coupon.

### 6.7.13.2 Coupon Installations Locations

Coupons should be installed at all locations where additional cathodic protection information is desired. This would include the following locations: particularly corrosive environments, locations of past leaks, midway between cathodic protection current sources, tops of dry rocky hills, and wet low-lying valleys.

The number of coupons to be installed is based on pipeline condition. Generally, the worse a structure's coating, the more cathodic protection coupons can help determine the effectiveness of the cathodic protection system.

Coupons should be installed in close proximity and within the same electrolyte as the structure they are intending to represent.

Typically, coupons are installed near the bottom of the pipeline. This area tends to be more corrosive than the top of the pipeline.

### 6.7.13.3 Installation Procedures

Several construction methods can be used to install coupon test stations (Figure 6-17):

- Installation during the pipeline construction process or during pipeline inspection activities
- Auguring using a drill bit device
- Vacuum excavation

- Hand digging

**Figure 6-17**  
**Coupon Test Stations**

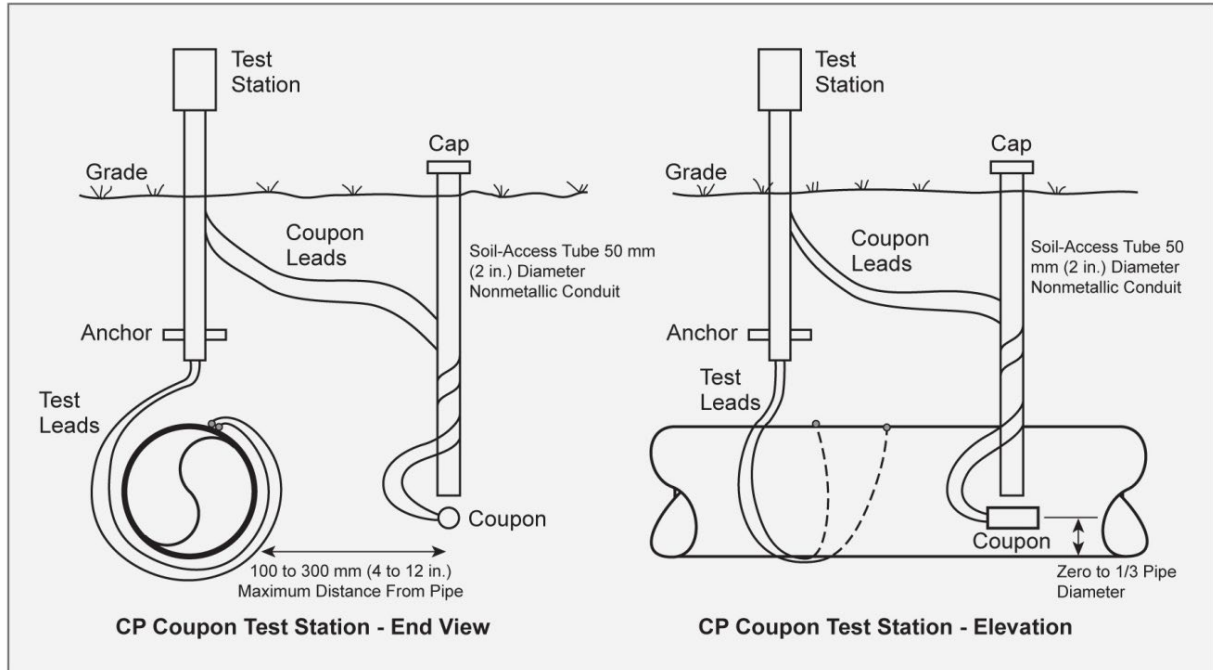

#### Acronyms and Abbreviations

in: inch

mm: millimeter

Several important techniques should be observed during installation to ensure that the coupons operate as designed.

1. Compact the soil surrounding the coupon to prevent settlement and air voids. Soil compaction ensures the coupon maintains good contact with the electrolyte environment.
2. Install coupons in the same backfill as the structure under protection. This helps ensure the coupon polarization characteristics mimic those of the structure.
3. The coupons should be installed near the bottom and within 4 to 12 inches of the pipeline. Make sure not to shield the structure from cathodic protection current.
4. It may be beneficial to install coupons on both sides of large-diameter pipelines because local soil and coating conditions can vary.

### 6.7.14 DGI4 - Linear Galvanic Anodes, Linear Grounding Ribbon Anodes, and Grounding Mats

Beside other benefits, linear galvanic anodes used for pipelines several miles long in areas with high soil resistivity and/or remote locations with less access to nonexistence of power will provide for a cost-effective solution to protect pipelines. Design, installation, and commissioning of a linear galvanic anode system is the same as with a galvanic cathodic protection system.



Linear grounding ribbon anodes are also a safety device installed along pipelines that run parallel to high-voltage electric lines. Instances can occur where AC voltage is induced onto the pipeline resulting in a possible electrical shock hazard. If the pipeline and aboveground appurtenances are not properly grounded, a person touching a metallic portion of the structure can receive an electrical shock.

Removed for Security

### 6.7.14.2 Installation Requirements

This section describes typical installation methods for both galvanic ribbon anodes and grounding mats.

#### A. Grounding Ribbon/Mat Material

Zinc anodes are used as the material for both linear grounding ribbons and grounding mats for several reasons:

- Low anode to earth resistance
- Low anode consumption rate (resulting in a longer life)
- Higher anode efficiencies
- Ease of installation

#### B. Linear Grounding Ribbon Anodes

Linear grounding ribbon anodes are normally installed concurrently with the pipeline installation. The system consists of either one or two ribbon anodes installed along the length of pipeline paralleling the overhead AC electric transmission lines. Backfill surrounding the grounding ribbons is the same type that surrounds the pipeline. The anodes should be attached to the pipeline via a decoupler at intervals not exceeding 1,000 ft. The decoupler will block DC/cathodic current flow between pipeline and the ribbon anodes, resulting a longer life for the anodes with or without implementation of an impressed current cathodic system. When the ribbon anodes are connected to the pipeline without decouplers, an impressed current cathodic system must be installed to protect the ribbon anodes and pipeline as whole. The connection to the pipeline most often is completed in an aboveground test station. A test station allows for disconnection or short circuit of the anodes so that the pipeline cathodic protection levels and direction of current flow can be properly tested.

### C. Ground Mats

Ground mats are constructed of zinc ribbon anodes that are either fabricated in a mesh-type pattern or installed in spiral shape around the aboveground structure. Either form of mat will incorporate a pig tail connection that is either routed to the cathodic protection test station or directly connected to the pipeline.

Prefabricated ground mats are configured in a mesh that is 6 ft by 6 ft, 8 ft by 8 ft, or other spiraled-type design. The mats are intended to be installed surrounding the aboveground appurtenance (such as an air release or other valve unit). The mats should be installed approximately 6 ft extend beyond the appurtenance and with 1 ft cover of high resistivity and well-draining backfill materials.

SPU also has installed pre-fabricated square, mesh copper ground mats inside vaults and other above ground structures to mitigate against potential shock hazard in the vicinity along Beacon Ave where SPU pipelines pass between the joint Puget Sound Energy and Bonneville Power Administration electrical substations.

### D. On-Site Ground Mat Fabrication

On-Site fabrication of a ribbon grounding mat is the most common installation method:

1. Excavate around the structure such that the depth of grounding mat installation is approximately 1 ft.
2. Uncoil a length of zinc ribbon from its spool.
3. Secure one end of the ribbon adjacent to the structure. Ensure that the ribbon does not come into physical contact with the structure.
4. Bend the anode as required, spool the anode around the perimeter of the structure and firmly secure the anode at every 2-3 ft spacing.
5. Continue to lay out the ribbon in a continuous fashion around the structure, maintaining a 1-ft distance between successive anode ribbon rings.
6. Installation of the ribbon should continue until it is a minimum of 6 ft from the structure.
7. Expose 1 inch of steel core at each end of the ribbon by removing the zinc material.
8. Splice a #8 AWG header cable to each end of the anode and route the two cables to the cathodic protection test station.
9. Backfill the anode with gravel that drains well.
10. Connect the grounding mat leads to the structure within the test station. Complete testing as described in the following section.

#### 6.7.14.3 Post-Installation System Checkout

##### A. Linear Grounding Ribbon Checkout

Verification of proper system operation should be conducted after installation and backfilling work has been completed.

1. Turn off all pipeline current sources affecting the pipeline in the vicinity of the installation.
2. With all anode ribbons disconnected from the pipeline, record native state pipe-to-soil and anode-to-soil potentials.
3. Connect all anode ribbons, bypassing all decouplers if any and record ON readings at each test station.
4. Turn on and cycle all other current sources such as impressed current cathodic protection systems.
5. Record both ON and Instant OFF potentials of the structure with the grounding ribbons connected with and without decouplers. Note direction of current flow.
6. Adjust cathodic protection system to maintain an Instant OFF potential no more negative than -1250mV CSE with bypassing decouplers. Potentials more negative than -1250mV may create an alkaline environment surrounding the anode, resulting in accelerated consumption of the zinc material.
7. Reconnect decouplers to the grounding ribbon anodes after performing the above readings.

### **B. Ground Mat Checkout**

Before hooking up the grounding mat, record electrical potentials both parallel and perpendicular (for a total of four sets of readings) to the pipeline. Potentials should be measured starting nearest the aboveground appurtenance and moving away at 1-ft intervals. A minimum of eight readings in each direction should be made.

Hook up the grounding mat and record ON potentials at the same locations described in the previous step. There should be no more than a 25mV potential difference between successive readings in each direction. If a large voltage gradient is measured, allow the structure to polarize for one week. Repeat the ON potential data collection. If a potential difference greater than 25mV still exists, additional anode material may need to be added.

Measure magnitude and direction of current flow between the structure and the grounding mat.

Removed for Security











































































































































































































































## 6.9 RESOURCES

---

### Documents

1. Control of Pipeline Corrosion Second Edition, A.W. Peabody, AMPP/NACE Press, 2001.
2. Ground Mat Resistance Testing Procedures, Power System Maintenance Manual, Western Area Power Administration, February 1990.
3. AMPP/NACE Cathodic Protection Technician Course, NACE International 2006.
4. AMPP/NACE RP0196-2004 Galvanic Anode Cathodic Protection of Internal Submerged Surfaces of Steel Water Storage Tanks
5. AMPP/NACE SP0388-2007 Impressed Current Cathodic Protection of Internal Submerged Surfaces of Steel Water Storage Tanks
6. AMPP/NACE Standard Test Method – Measurement of Protective Coating Electrical Conductance on Underground Pipelines
7. AMPP/NACE RP0104-2004 The Use of Coupons for Cathodic Protection Monitoring Applications for help in developing a uniform strategy for use of coupons.
8. *Stray Current Corrosion*, Michael J. Szeliga Editor, AMPP/NACE International 1994.

### Websites

- SPU corrosion protection SharePoint website

Removed for Security

