



CONSTRUCTION STORMWATER CONTROL

City of Seattle | Stormwater Manual



Note:

Some pages in this document have been purposely skipped or blank pages inserted so that this document will copy correctly when duplexed.

Table of Contents

Volume 2 – Construction Stormwater Control	i
CHAPTER 1 - Introduction	1-1
1.1. What is the Purpose of this Volume?	1-1
1.2. How Does this Volume Apply to Construction?.....	1-1
1.2.1. City of Seattle Requirements	1-1
1.2.2. How to Use This Volume.....	1-2
1.3. What is Considered “Compliance”?.....	1-2
1.3.1. Surface Water Quality	1-2
1.3.2. Groundwater Quality.....	1-3
1.3.3. Downstream Infrastructure and Resources	1-3
1.3.4. Upstream Analysis of Runoff Entering a Construction Site.....	1-4
1.4. What is Considered “Out of Compliance”?	1-4
1.5. Purpose of Construction Stormwater Best Management Practices (BMPs).....	1-5
CHAPTER 2 - Construction Stormwater Control and Soil Management Plans.....	2-1
2.1. Small Project Construction Stormwater Control and Soil Management Plan	2-1
2.2. Large Project Construction Stormwater Control and Soil Management Plan	2-2
2.3. Certified Erosion and Sediment Control Lead	2-3
2.3.1. Description.....	2-3
2.3.2. Purpose.....	2-3
2.3.3. Conditions Where Practice Applies	2-3
2.3.4. Certification Criteria.....	2-3
2.3.5. Duties and Responsibilities.....	2-4
CHAPTER 3 - Selecting Construction Stormwater Controls.....	3-1
CHAPTER 4 - Standards and Specifications for Construction Erosion, Sediment, and Flow Control Practices	4-1
4.1. Cover Practices	4-2
4.1.1. Temporary Cover Practices	4-2
4.1.2. Permanent Cover Practices	4-14
4.2. Erosion Control Practices	4-26
4.2.1. Temporary Erosion Control BMPs.....	4-26
4.2.2. Permanent Erosion Control BMPs.....	4-42
4.2.3. Temporary or Permanent Erosion Control BMPs	4-43
4.3. Sediment Control Practices.....	4-49
4.3.1. BMP E3.10: Filter Fence	4-50
4.3.2. BMP E3.20: Gravel Filter Berm	4-54
4.3.3. BMP E3.25: Inlet Protection.....	4-55
4.3.4. BMP E3.30: Vegetated Strip.....	4-60

- 4.3.5. BMP E3.35: Straw Wattles, Compost Socks, and Compost Berms4-61
- 4.3.6. BMP E3.40: Sediment Trap4-66
- 4.3.7. BMP E3.50: Portable Sediment Tank.....4-70
- 4.3.8. BMP E3.60: Construction Stormwater Filtration4-73
- 4.3.9. BMP E3.65: Cleaning Inlets and Catch Basins4-76
- 4.3.10. BMP E3.70: Street Sweeping and Vacuuming4-78
- 4.4. Flow Control & Dewatering Practices4-79
 - 4.4.1. BMP E4.10: Temporary Flow Control During Construction4-79
 - 4.4.2. BMP E4.20: Temporary Groundwater Dewatering4-83
- CHAPTER 5 - Source Control & Monitoring Practices for Construction Pollutants
- Other than Sediment 5-1
- 5.1. Source Control Practices 5-1
 - 5.1.1. BMP C1.15: Material Delivery, Storage, and Containment 5-3
 - 5.1.2. BMP C1.20: Use of Chemicals During Construction 5-5
 - 5.1.3. BMP C1.25: Demolition of Buildings 5-7
 - 5.1.4. BMP C1.30: Building Repair, Remodeling, and Construction5-10
 - 5.1.5. BMP C1.35: Sawcutting and Paving Pollution Prevention5-13
 - 5.1.6. BMP C1.45: Solid Waste Handling and Disposal5-14
 - 5.1.7. BMP C1.50: Disposal of Asbestos and Polychlorinated Biphenyls (PCBs)5-18
 - 5.1.8. BMP C1.55: Airborne Debris Curtain5-19
 - 5.1.9. BMP C1.56: Concrete Handling5-21
 - 5.1.10. BMP C1.58: Concrete Washout Area.....5-24
 - 5.1.11. BMP C1.59: High pH Neutralization Using CO₂.....5-28
- 5.2. Monitoring Practices5-31
 - 5.2.1. Turbidity Monitoring5-31
 - 5.2.2. pH Monitoring5-31

Attachments

Attachment 1 Checklist to Select Small and Large Project Construction BMPs

Tables

- Table 2. Temporary Erosion Control Seeding Mixture.^a 4-5
- Table 3. Guide to Mulch Materials, Rates, and Uses. 4-7
- Table 4. Permanent Seeding Mixture.^a4-21
- Table 5. Design Criteria for Earth Dike.....4-48
- Table 6. Design Criteria for Drainage Swale.....4-48

Table 7.	Geotextile Standards.	4-52
Table 8.	Vegetated Strip Implementation Criteria.	4-60
Table 9a.	Handling, Hauling, and Destination Requirements for Targeted Materials.	5-16
Table 9b.	Handling, Hauling, and Destination Requirements for Targeted Materials.	5-17

Figures

Figure 1.	Hydroseeding Method.	4-3
Figure 2a.	Mat Installation on Slope.	4-10
Figure 2b.	Mat Installation on a Channel.	4-11
Figure 3.	Stockpile Covered with Plastic Sheeting.	4-12
Figure 4.	Preserving Vegetation.	4-15
Figure 5.	Vegetated Buffer Zone.	4-18
Figure 6.	Stabilized Construction Access.	4-28
Figure 7.	Stabilized Construction Access.	4-29
Figure 8.	Tire Wash Details.	4-32
Figure 9.	Check Dams.	4-36
Figure 10.	Triangular Silt Dike Cut Section.	4-38
Figure 11.	Using a Water Truck for Dust Control.	4-40
Figure 12.	Earth Dike and Drainage Swale.	4-46
Figure 13.	Filter Fence Installed on a Slope.	4-50
Figure 14.	Filter Fence Details.	4-53
Figure 15.	Block and Gravel Curb Inlet Protection.	4-56
Figure 16.	Curb and Gutter Barrier.	4-57
Figure 17.	Straw Wattles or Compost Sock for Inlet Protection.	4-61
Figure 18.	Straw Wattle Details.	4-64
Figure 19.	Cross Section of Sediment Trap and Outlet.	4-68
Figure 20.	Concrete Washout Facility.	5-26
Figure 21.	Prefabricated Concrete Washout Container with Ramp.	5-26

CHAPTER 1 – Introduction

1.1. What is the Purpose of this Volume?

This volume is designed to help businesses, individuals, responsible parties, and public agencies in the City of Seattle (City) implement best management practices (BMPs) at project sites to:

- Prevent impacts to the public drainage system or public combined sewer and downstream resources.
- Stop pollutants from contaminating stormwater.

Uncontrolled stormwater can threaten downstream resources, such as public storm drains, real property, and natural habitat. It can also pollute our public drainage system or public combined sewer and receiving waters (e.g., creeks, streams, rivers, lakes, and Puget Sound). The resulting impacts can pose serious risks to the health, safety, and welfare of humans and the environment.

1.2. How Does this Volume Apply to Construction?

This volume applies to all construction projects in Seattle, defined in the Seattle Municipal Code (SMC), Chapter 22.801.170 as the addition or replacement of hard surface or the undertaking of land-disturbing activity.

The construction stormwater BMPs and requirements in this volume have been integrated from many programs and regulations, including the provisions of the:

- Federal Clean Water Act
- Federal Coastal Zone Management Act
- City of Seattle Phase I NPDES Municipal Stormwater Permit
- Puget Sound Partnership Action Agenda
- Washington State Department of Ecology (Ecology) Construction Stormwater General Permit
- City of Seattle Stormwater Code

1.2.1. *City of Seattle Requirements*

Under current City law, the responsible party is liable for water quality problems and impacts to downstream resources caused by construction work. Many construction projects with land disturbance require a permit from the Seattle Department of Construction and Inspections (SDCI) and most projects that occur in the street right-of-way require a permit from Seattle Department of Transportation (SDOT). Regardless of whether or not a permit is required, all construction stormwater must be controlled to prevent negative impacts.

If you are planning a construction project and need information concerning the applicable stormwater requirements, the first step is reviewing *Volume 1 – Project Minimum Requirements* and the applicable elements of the Stormwater Code. Code sections to review include, but are not limited to, SMC 22.805.020 (particularly subsection D), SMC 22.807.020 (for requirements related to drainage control review), and the definitions in SMC 22.801.

1.2.2. *How to Use This Volume*

- *Chapter 1* (this chapter) outlines the purpose and content of this volume.
- *Chapter 2* provides Construction Stormwater Control and Soil Management Plan requirements.
- *Chapter 3* provides an explanation for BMP selection based on project category and required BMPs.
- *Chapters 4 and 5* provide the standards and specifications for the BMPs contained in this volume.

Several appendices also support the information contained in this manual. These appendices include:

- *Appendix A* – Definitions
- *Appendix E* – Additional Stormwater Design Requirements
- *Appendix F* – Hydrologic Analysis and Design

1.3. What is Considered “Compliance”?

The City expects that the selection and implementation of appropriate BMPs outlined in this volume and other applicable manuals will result in compliance with the Stormwater Code’s minimum requirements for project site stormwater pollution prevention control. If compliance is not achieved, additional measures must be implemented.

Proper implementation and maintenance of appropriate BMPs is critical to control any adverse water quality or downstream resource impacts from construction activity.

1.3.1. *Surface Water Quality*

Pollutants that might be expected in the discharge from project sites include, but are not limited to, sediment, pH, and petroleum products. Public drainage systems, public combined sewers, and receiving waters can be contaminated by direct discharges of these pollutants or from stormwater discharges that have become contaminated by direct contact with the pollutants or pollutants absorbed into sediment.

Soil erosion, sheet erosion, or downstream channel erosion can cause turbid (muddy) stormwater when the sediment contacts rainwater; this is the most common and visible form of construction stormwater pollution. The resulting high turbidity can adversely impact receiving waters if not properly controlled using the BMPs contained in this volume.

The sources of other commonly encountered pollutants include materials and chemicals used during day-to-day construction activities, such as concrete pouring, paving, truck and heavy equipment operation, and maintenance activities. Low and high pH (acidity) and petroleum products can adversely impact public drainage systems, public combined sewers, and receiving waters in more than one way. One direct impact is reduced water quality by introducing pollutants; another impact is decreased function of the public drainage system or public combined sewer by fouling and spreading pollutants in the pipe network.

Water Quality Standards for Surface Waters of the State of Washington are defined in the Washington Administrative Code (WAC) Chapter 173-201A. Contractors and other responsible parties must be familiar with the current water quality standards, particularly those targeting typical construction-related pollutants. For more information on surface water quality standards and specific criteria, refer to Ecology’s website (<https://ecology.wa.gov/Water-Shorelines/Water-quality/Water-quality-standards/Criteria>).

It is illegal to discharge dirty water to the drainage system; however, the activity may be permitted for disposal in the sanitary sewer if authorized by the City and King County.

If sanitary sewer disposal is not available or not allowed, the contaminated water must be treated or transferred to a holding tank where it must be picked up for offsite disposal.

1.3.2. Groundwater Quality

Water quality standards for groundwaters of the State of Washington are designed to meet the goal of protecting the current and future beneficial uses of groundwater by preventing groundwater contamination. The primary water quality consideration for stormwater discharges to groundwater from project sites is the control of contaminants other than sediments.

For more information on groundwater quality standards, refer to Ecology’s website (<https://ecology.wa.gov/Water-Shorelines/Water-quality/Groundwater/Groundwater-quality-standards>).

1.3.3. Downstream Infrastructure and Resources

The public drainage system or public combined sewer, real property, and natural habitat can be adversely impacted when an uncontrolled discharge leaves a project site. Common negative impacts can include soil erosion, flooding, habitat degradation, subsequent destructive after-effects due to increases in the stormwater volume, velocity, and peak flow rate, or some combination of these impacts.

Regulations and guidelines in the Stormwater Code and this volume may require construction of temporary stormwater retention, detention, or infiltration facilities to protect downstream resources. It is important to note that these facilities must be functioning prior to implementation of land-disturbing activity. If a permanent facility is used to control flows during construction, refer to *Volume 3* for design guidelines and criteria. *Volume 3* also provides design criteria to protect permanent infiltration facilities from siltation during the construction phase of the project. For most parcel-based projects, the temporary BMPs to be implemented from this volume should be sized to accommodate a storm with a 2-year or a 10-year recurrence interval (refer to specific BMPs for additional guidance regarding sizing).

Additional impacts to downstream infrastructure and resources can occur from dewatering activities as well. Projects that are required to comply with the Minimum Requirements for Flow Control must include the dewatering discharge volume as part of the total release rate allowed from the site.

1.3.4. Upstream Analysis of Runoff Entering a Construction Site

The designer must evaluate whether stormwater runoff from any offsite areas could flow onto the project site. If so, any offsite runoff must be re-routed around the construction site in a way that will not alter the water quality of the runoff or alternatively the construction stormwater BMPs must be designed to fully accommodate the offsite runoff. When sizing BMPs to account for offsite runoff entering the project site, determine the full area of the upstream basin that contributes runoff onto the site. If survey information is not available for the upstream basin, use topographic maps provided by the City or King County to determine the size of the basin and use aerial photos or field investigation to determine the existing land cover conditions. Size any sediment traps, tanks, or filtration systems to include the additional upstream flows; additional tanks may be necessary to collect run-on from upstream areas, especially during periods of heavy rain. If re-routing the runoff around the site, verify that the pipes or swales have capacity for the calculated flowrates from the upstream areas.

1.4. What is Considered “Out of Compliance”?

The Stormwater Code outlines compliance requirements for construction stormwater pollution prevention. If the required BMPs implemented do not effectively address erosion issues or the discharge of pollutants, additional BMPs may be required.

Violations are enforceable under the City’s Stormwater Code SMC 22.808.030 and *Volume 5 – Enforcement* of this manual.

Examples of when a project would be considered out of compliance with the Stormwater Code include:

- A discharge leaves the project site and causes or contributes to a prohibited discharge, a turbidity or pH that exceeds the benchmarks, a known or likely violation of water quality standards in the receiving water, or violates the Phase I NPDES Municipal Stormwater General Permit (SMC, Chapter 22.805.010).
- A project that has not received all required permits and discharges to the public drainage system or public combined sewer.
- A discharge of oil or other harmful substances leaves the project site and enters the public combined sewer, public drainage system, or receiving waters.
- Sediment is tracked off the project site.
- A project site does not have a Construction Stormwater Control and Soil Management Plan.

This is not a comprehensive list of out of compliance events. If there is a question about compliance, visit the SDCI Applicant Services Center on the 20th floor of the Seattle Municipal Tower, 700 Fifth Avenue, Seattle, Washington 98124, or the City’s website (www.seattle.gov/sdci).

1.5. Purpose of Construction Stormwater Best Management Practices (BMPs)

Construction stormwater BMPs are measures implemented to protect the public drainage system, public combined sewer system, and receiving waters from pollution and impacts to downstream resources during land-disturbing and other construction activities (refer to SMC, Chapter 22.801.030). For example:

- Construction activities such as clearing, grading, excavation, and stockpiling disturb established vegetation, trees, and stable soils.
- Concrete, asphalt, treated timber, and other construction materials involve chemicals and contaminants that must be retained on the project site.
- Construction activities can increase the volume and/or peak flow rate of discharges leaving the site. The discharges can increase sediment and pollution in receiving waters.
- Construction equipment introduces the potential for spills involving oil, gasoline, or other petroleum products.

In general, construction BMPs help prevent pollution from leaving the project site, eliminate ponding, flooding, or both in the public right-of-way, and minimize impacts to the public drainage system or public combined sewer. These measures fall into two general categories—erosion and sedimentation control and control of pollutants other than sediment.

Erosion and sediment control BMPs can be grouped according to three methods:

- Cover practices: a temporary or permanent cover designed to stabilize disturbed areas.
- Erosion control practices: physical measures designed and constructed to prevent erosion of project site soils.
- Sediment control practices: prevent eroded soils from leaving the project site by trapping them in a depression, filter, or other barrier.

Pollutants other than sediment are primarily controlled using good “housekeeping” practices and other methods outlined in this volume to reduce the risk of pollutant contact with stormwater or direct discharge to receiving waters.

Refer to *Volume 4 – Source Control*. This volume should be reviewed to ensure that all requirements are being met for each project.

CHAPTER 2 – Construction Stormwater Control and Soil Management Plans

The Construction Stormwater Control and Soil Management Plan applies best management practices (BMPs) that fall within the 19 elements of water quality, air quality, and downstream resource protection and are required by the Stormwater Code (SMC, Chapter 22.805.020.D). These 19 elements (refer to *Chapter 3*) cover general water and air quality protection strategies, including:

- Limiting project site impacts
- Protecting the public drainage system, combined and sanitary sewers, and downstream receiving waters
- Preventing erosion and sedimentation
- Managing activities and sources

Project designers must review the applicable elements of SMC 22.805.020.D and ensure the specific requirements under each of the 19 elements in the code are fully addressed by the project site stormwater pollution prevention controls.

2.1. Small Project Construction Stormwater Control and Soil Management Plan

For Small Projects (i.e., involving less than 5,000 square feet of new plus replaced hard surface or less than 10,000 square feet of land-disturbing activity), the applicant must submit a Construction Stormwater Control and Soil Management Plan that demonstrates how the project will cover the required elements by using BMPs contained in this volume.

The first step after reviewing the Stormwater Code requirements is to refer to Attachment 1, Table 1a, Checklist to Select Small Project Construction BMPs. Small Projects are required to implement BMPs as dictated by site conditions. If a required element is not applicable, the reason must be justified briefly on the checklist and in detail in the plan narrative.

The next step is to prepare the Small Project Construction Stormwater Control and Soil Management Plan narrative section that describes the project and selected BMPs.

The narrative, and subsequently prepared plan, must include:

- The name, address, and phone number of the owner or contact person.
- A north arrow, lot number and plat, address, date, and street name fronting the structure.
- A description of all existing and proposed structures on the project site.
- Limits of disturbance, including all clearing, grading, and other land-disturbing activity.
- The location and size of all streams, swales, and drainage channels on or within 25 feet of the project site that may be impacted by or affect the drainage of the project site to be developed.

- A description of all existing stormwater pipes and their diameters and approximate lengths.
- The direction and location of stormwater runoff entering and exiting the project site from all adjacent properties (this may be done with topographic contour lines).
- “Point of discharge” labels for all discharges of stormwater, wastewater, etc. that leave the site or will be infiltrated on site.
- System discharge flowrate limits for construction stormwater, groundwater dewatering, and process water discharges. Refer to SPU Design Standards and Guidelines Appendix 18B Temporary Discharges for allowable discharge rates.
- The types of systems, including On-site BMPs, that will be used to convey runoff away from the proposed structures, if applicable.
- The steps that will be taken to retain native vegetation and minimize hard surfaces to the maximum extent feasible
- The types of wastewater that may be generated during the work and the types of collection or conveyance systems used to manage the waste, including disposal options.
- Location(s) where stormwater discharges are collected from the project site, including individual (point) flow and sheet flow (i.e., overland flow).
- A description of how construction will be phased so that only those areas actively being worked are uncovered.
- The construction entrance(s) and exit(s), as applicable.
- Stockpile and excavation locations.

First complete the narrative followed by the plan sheet. The plan sheet is not required to be prepared by a civil engineer; however, it is required to graphically show the information provided in the narrative, including how BMPs will be implemented.

The Construction Stormwater Control and Soil Management Plan can be obtained from the Seattle Department of Construction and Inspections (SDCI) web page, which has both pdf and CAD formats ([www.seattle.gov/sdci/codes/codes-we-enforce-\(a-z\)/stormwater-code](http://www.seattle.gov/sdci/codes/codes-we-enforce-(a-z)/stormwater-code)).

The applicant is responsible for modifying the Construction Stormwater Control and Soil Management Plan whenever directed to by the Inspector or when there is a change in design, construction, operation, or maintenance at the project site that has, or could have, a significant effect on the discharge of pollutants.

2.2. Large Project Construction Stormwater Control and Soil Management Plan

For Large Projects (i.e., greater than 5,000 square feet of new plus replaced hard surface or 10,000 square feet and greater of land-disturbing activity), the applicant must submit a Large Project Construction Stormwater Control and Soil Management Plan, including narrative and plan sheet(s), that demonstrate how the project will cover the 19 elements by using BMPs contained in this volume.

The first step is to refer to Attachment 1, Table 1b, Checklist to Select Large Project Construction BMPs. Large Projects are required to implement BMPs from all 19 elements. If a required element is not applicable, the reason must be justified briefly on the checklist and in detail in the plan narrative. The next step is to prepare the Large Project Construction Stormwater Control and Soil Management Plan narrative section and plan sheets that describe the project and selected BMPs. The Large Project Construction Stormwater Control and Soil Management Plan includes the same narrative and plan details required for the Small Project Construction Stormwater Control and Soil Management Plan (*Section 2.1*) plus additional narrative and plan sheet(s), as applicable.

The Large Project Construction Stormwater Control and Soil Management Plan must be prepared by a qualified professional. When the plan includes engineering calculations, it must be stamped and signed by an engineer licensed in the State of Washington.

2.3. Certified Erosion and Sediment Control Lead

2.3.1. *Description*

The project proponent must have a project representative who is a Certified Erosion and Sediment Control Lead (CESCL). The project proponent designates at least one person as the responsible representative in charge of erosion and sediment control and water quality protection. The designated person must be the CESCL.

2.3.2. *Purpose*

The purpose of a designated CESCL is to ensure compliance with all city, county, state, and federal erosion and sediment control and water quality requirements.

2.3.3. *Conditions Where Practice Applies*

A CESCL should be designated and made available on Large Projects. The CESCL must perform all duties and take on all responsibilities listed in this BMP.

2.3.4. *Certification Criteria*

The training and administrative requirements for the person designated as the CESCL are listed below. The CESCL should:

- Have a current certificate proving attendance in an erosion and sediment control (ESC) training course that meets the minimum ESC training and certification requirements established by the Washington State Department of Ecology (Ecology). Ecology maintains a list of ESC training and certification providers on its website (<https://ecology.wa.gov/Regulations-Permits/Permits-certifications/Certified-erosion-sediment-control>).

OR

Be a Certified Professional in Erosion and Sediment Control (CPESC). For additional information on the CPESC certification, refer to the EnvironCert International, Inc., website (www.envirocertintl.org/cpesc/).

- Certification must remain valid for the full duration of construction.

- The CESCL should have authority to act on behalf of the contractor or developer and should be available, on call, 24 hours per day throughout the period of construction.
- The name, telephone number, fax number, and address of the designated CESCL must be recorded in the Large Project Construction Stormwater Control and Soil Management Plan.
- A CESCL may provide inspection and compliance services for multiple construction projects in the same geographic region.

2.3.5. Duties and Responsibilities

The duties and responsibilities of the CESCL should include, but are not limited to, the following:

- Maintain all applicable documentation, permits, and plans on site at all times.
- Direct BMP installation, inspection, maintenance, modification, and removal.
- Update all project drawings and plans with changes made.
- Keep daily logs and inspection reports. Inspection reports should include:
 - Inspection date and time.
 - Weather information: general conditions during inspection and approximate amount of precipitation since the last inspection.
 - A summary or list of all BMPs implemented, including observations of all erosion and sediment control structures or practices. The following should be noted:
 - Locations of BMPs inspected
 - Locations of BMPs that need maintenance
 - Locations of BMPs that failed to operate as designed or intended
 - Locations of where additional or different BMPs are required
- Duties relating to temporary dewatering (BMP E4.20).
- Visual monitoring results, including a description of discharged stormwater. The presence of suspended sediment, turbid water, discoloration, and oil sheen should be noted, as applicable.
- Any water quality monitoring performed during inspection.
- General comments and notes, including a brief description of any BMP repairs, maintenance, or installations made as a result of the inspection.
- Facilitate, participate in, and take corrective actions resulting from inspections performed by outside agencies or the owner.
- Contact, or direct staff to contact, SPU's Operations Response Center (206-386-1800) and other appropriate agencies (e.g., Ecology, at 206-594-0000) if a discharge of turbid or otherwise polluted water enters the City's MS4, a receiving waterbody, or both (Note: MS4 includes streets with drainage assets).

The CESCL is responsible for modifying the Construction Stormwater Control and Soil Management Plan whenever there is a change in design, construction, operation, or maintenance at the project site that has, or could have, a significant effect on the discharge of pollutants, or when directed to by the Inspector.

CHAPTER 3 – Selecting Construction Stormwater Controls

Projects must implement best management practices (BMPs) from the 19 elements of general water quality and downstream resource protection strategies listed in SMC, Chapter 22.805.020.D. Refer to *Section 2.1* and *Section 2.2* for a discussion of Small and Large Project Construction Stormwater Control and Soil Management Plans, including the level of detail required for submittals. Also reference *Volume 1, Minimum Requirements for All Projects - Chapter 3.4 - Construction Site Stormwater Pollution Prevention Control* for additional information

Attachment 1, Tables 1a and 1b present each of the 19 elements and required or recommended BMPs for Small and Large Project plans, respectively. Required BMPs must be implemented throughout construction. If a required element is not applicable, the reason must be justified briefly on the checklist and in detail in the plan narrative. The recommended BMPs are intended to provide further guidance for minimizing potential stormwater pollution resulting from activities. Using these additional BMPs is encouraged. BMPs referenced as “Ecology BMPs” can be found in Volume II of the Washington State Department of Ecology (Ecology) Stormwater Management Manual for Western Washington (SWMMWW), 2024 edition.

Refer to Attachment 1, Table 1a or 1b and the pre-application report (PAR) prepared by the City to identify the appropriate required and recommended BMPs for your project. The Small Project Construction Stormwater Control and Soil Management Plan and the Large Project Construction Stormwater Control and Soil Management Plan should document each selected BMP and its implementation, maintenance, and inspection requirements.

Note: The City may require additional measures beyond what are shown on the approved plan depending on Stormwater Code requirements, construction sequencing, and actual site conditions.

Stormwater Code Language
<p>SMC 22.805.020.D – <i>Minimum Requirements for Construction Stormwater Pollution Prevention Plan. Temporary and permanent construction controls shall be used to accomplish [the 19 construction site stormwater pollution prevention control requirements outlined in SMC 22.805.020.D and Volume 2, Construction Stormwater Control]. All projects are required to meet each of the elements below or document why an element is not applicable. Additional controls may be required by the Director when minimum controls are not sufficient to prevent erosion or transport of sediment or other pollutants from the site.</i></p> <ol style="list-style-type: none"> 1. <i>Mark clearing limits and environmentally critical areas. Within the boundaries of the project site and prior to beginning land disturbing activities, including clearing and grading, clearly mark all clearing limits, easements, setbacks, all environmentally critical areas and their buffers, and all trees and drainage courses that are to be preserved within the construction area.</i> 2. <i>Retain top layer. Within the boundaries of the project site, the duff layer, topsoil, and native vegetation, if there is any, shall be retained in an undisturbed state to the maximum extent feasible. If it is not feasible to retain the top layer in place, it should be stockpiled on-site, covered to prevent erosion, and replaced immediately upon completion of the land disturbing activities to the maximum extent feasible.</i> 3. <i>Establish construction access. Limit construction vehicle access, whenever possible, to one route. Stabilize access points and minimize tracking sediment onto public roads. Promptly remove any sediment tracked off site.</i>

Stormwater Code Language

4. *Protect downstream properties and receiving waters. Protect properties and receiving waters downstream from the development sites from erosion or flooding due to increases in the volume, velocity, duration, and peak flow rate of drainage water from the project site. If it is necessary to construct flow control facilities to meet this requirement, these facilities shall be functioning prior to implementation of other land disturbing activity. If permanent infiltration facilities are used to control flows during construction, these facilities shall be protected from siltation during the construction phase of the project.*
5. *Prevent erosion and sediment transport from the site. Pass all drainage water from disturbed areas through a sediment trap, sediment pond, or other appropriate sediment removal BMP before the water leaves the site or prior to discharge to an infiltration facility. Sediment controls intended to trap sediment on site shall be constructed as one of the first steps in grading and shall be functional before other land disturbing activities take place. BMPs intended to trap sedimentation shall be located in a manner to avoid interference with the movement of juvenile salmonids attempting to enter off-channel areas or drainages. Provide and maintain natural buffers around surface waters, direct stormwater to vegetated areas to increase sediment removal and maximize stormwater infiltration where feasible.*
6. *Prevent erosion and sediment transport from the site by vehicles. Whenever construction vehicle access routes intersect paved roads, the transport of sediment onto the paved road shall be minimized. If sediment is transported onto a paved road surface, the roads shall be cleaned thoroughly at the end of each day. Sediment shall be removed from paved roads by shoveling or sweeping and shall be transported to a controlled sediment disposal area. If sediment is tracked off site, roads shall be cleaned thoroughly at the end of each day, or at least twice daily during wet weather. Street washing is allowed only after sediment is removed, and street wash wastewater shall be prevented from entering the drainage system and receiving waters.*
7. *Stabilize soils. Prevent on-site erosion by stabilizing all exposed and unworked soils, including stock piles and earthen structures such as dams, dikes, and diversions. From October 1 to April 30, no soils shall remain exposed and unworked for more than two days. From May 1 to September 30, no soils shall remain exposed for more than seven days. Soils shall be stabilized at the end of the shift before a holiday or weekend if needed based on the weather forecast. Soil stockpiles shall be stabilized from erosion, protected with sediment trapping measures, and be located away from storm drain inlets, waterways, and drainage channels. Before the completion of the project, permanently stabilize all exposed soils that have been disturbed during construction.*
8. *Protect slopes. Erosion from slopes shall be minimized. Cut and fill slopes shall be designed and constructed in a manner that will minimize erosion. Off-site stormwater run-on or groundwater shall be diverted away from slopes and undisturbed areas with interceptor dikes, pipes, and/or swales. Pipe slope drains or protected channels shall be constructed at the top of slopes to collect drainage and prevent erosion. Excavated material shall be placed on the uphill side of trenches, consistent with safety and space considerations. Check dams shall be placed at regular intervals within constructed channels that are cut down a slope.*
9. *Protect storm drains. Prevent sediment from entering all storm drains, including ditches that receive drainage water from the project. Storm drain inlets protection devices shall be cleaned or removed and replaced as recommended by the product manufacturer, or more frequently if required to prevent failure of the device or flooding. Storm drain inlets made operable during construction shall be protected so that drainage water does not enter the drainage system without first being filtered or treated to remove sediments. Storm drain inlet protection devices shall be removed at the conclusion of the project. When*

Stormwater Code Language

- manufactured storm drain inlet protection devices are not feasible, inlets and catch basins must be cleaned as necessary to prevent sediment from entering the drainage control system.*
10. *Stabilize channels and outlets. All temporary on-site drainage systems shall be designed, constructed, and stabilized to prevent erosion. Stabilization shall be provided at the outlets of all drainage systems that is adequate to prevent erosion of outlets, adjacent stream banks, slopes, and downstream reaches.*
 11. *Control pollutants. Measures shall be taken to control potential pollutants and shall include, but not be limited to, the following measures:*
 - a. *All pollutants, including sediment, waste materials, and demolition debris, that occur on site shall be handled and disposed of in a manner that does not cause contamination of drainage water and pursuant to all applicable disposal laws.*
 - b. *Containment, cover, and protection from vandalism shall be provided for all chemicals, liquid products, petroleum products, and other materials that have the potential to pose a threat to human health or the environment.*
 - c. *On-site fueling tanks shall include secondary containment.*
 - d. *Maintenance, fueling, and repair of heavy equipment and vehicles involving oil changes, hydraulic system drain down, solvent and de-greasing cleaning operations, fuel tank drain down and removal, and other activities which may result in discharge or spillage of pollutants to the ground or into drainage water runoff shall be conducted using spill prevention and control measures.*
 - e. *Contaminated soils shall be removed and surfaces shall be cleaned immediately following any discharge or spill incident.*
 - f. *Wheel wash or tire bath wastewater shall be discharged to a separate on-site treatment system that prevents discharge to surface water, or to the sanitary sewer or combined sewer system with approval of the Director of SPU. Temporary discharges or connections to the public sanitary and combined sewers shall be made in accordance with Chapter 21.16 (Side Sewer Code).*
 - g. *Application of fertilizers and pesticides shall be conducted in a manner and at application rates that will not result in loss of chemical to drainage water. Manufacturers' label requirements for application rates and procedures shall be followed.*
 - h. *BMPs shall be used to prevent or treat contamination of drainage water by pH-modifying sources. These sources include, but are not limited to, recycled concrete stockpiles, bulk cement, cement kiln dust, fly ash, new concrete washing and curing waters, waste streams generated from concrete grinding and sawing, exposed aggregate processes, and concrete pumping and mixer washout waters. Construction site operators may be required to adjust the pH of drainage water if necessary to prevent a violation of water quality standards.*
 - i. *Construction site operators must obtain written approval from Ecology prior to using chemical treatment other than carbon dioxide (CO₂) dry ice, or food grade vinegar, to adjust pH.*
 - j. *Untampered water from water-only based shaft drilling for construction of building, road, and bridge foundations may be infiltrated provided the wastewater is managed in a way that prevents discharge to surface waters. Prior to infiltration, water from water-only based shaft drilling that comes into contact with curing concrete must be neutralized until pH is in the range of 6.5 to 8.5 (su).*
 - k. *Train all employees on proper BMPs for preventing illicit discharges, including spills.*
 12. *Control dewatering. When dewatering devices discharge on site, to a public drainage system, or to the public combined sewer, dewatering devices shall discharge into a sediment trap, sediment pond, gently sloping vegetated area of sufficient length to remove sediment contamination, or other sediment removal BMP. Foundation, vault, and trench dewatering waters must be discharged into a controlled drainage*

Stormwater Code Language

- system prior to discharge to a sediment trap or sediment pond. Clean, non-turbid dewatering water, such as unpolluted well-point groundwater, that is discharged to systems tributary to surface waters must not cause erosion or flooding. Highly turbid or contaminated dewatering water shall be handled separately from drainage water. For all projects with an excavation depth of 12 feet or more below the existing grade, all projects with an excavation depth of less than 12 feet located in an area expected to have shallow groundwater depths, and all projects with 5,000 square feet or more of new plus replaced hard surface or one acre or more of land disturbing activity, a dewatering analysis must be performed to determine dewatering flows and to verify that there is sufficient capacity in the downstream system (e.g., public drainage system or public combined sewer) for review and approval or disapproval by the Director.*
- 13. Maintain BMPs. All temporary and permanent erosion and sediment control BMPs shall be maintained and repaired as needed to assure continued performance of their intended function. All temporary erosion and sediment controls shall be removed within five days after final site stabilization is achieved or after the temporary controls are no longer needed, whichever is later. Trapped sediment shall be removed or stabilized on site. Disturbed soil areas resulting from removal shall be permanently stabilized.*
 - 14. Inspect BMPs. BMPs shall be periodically inspected. For projects with 5,000 square feet or more of new plus replaced hard surface or 7,000 square feet or more of land disturbing activity, site inspections shall be conducted by a Certified Erosion and Sediment Control Lead who shall be identified prior to construction and shall be present on-site or on-call at all times.*
 - 15. Execute construction stormwater control plan. Construction site operators shall maintain, update, and implement their construction stormwater control plan. Construction site operators shall modify their construction stormwater control plan to maintain compliance whenever there is a change in design, construction, operation, or maintenance at the site that has, or could have, a significant effect on the discharge of pollutants to waters of the state.*
 - 16. Minimize open trenches. In the construction of underground utility lines, where feasible, no more than 150 feet of trench shall be opened at one time, unless soil is replaced within the same working day, and where consistent with safety and space considerations, excavated material shall be placed on the uphill side of trenches. Trench dewatering devices shall discharge into a sediment trap or sediment pond.*
 - 17. Phase the project. Development projects shall be phased to the maximum extent feasible in order to minimize the amount of land disturbing activity occurring at the same time and shall take into account seasonal work limitations.*
 - 18. Install flow control and water quality facilities. Development projects required to comply with Section 22.805.080 (Minimum requirements for flow control) or Section 22.805.090 (Minimum requirements for treatment) shall install permanent flow control and water quality facilities to prevent erosion or transport of sediment or other pollutants from the site during construction.*
 - 19. Protect stormwater BMPs*
 - a. Protect all stormwater BMPs from sedimentation through installation and maintenance of erosion and sediment control BMPs. Restore the BMPs to their fully functioning condition if they accumulate sediment during construction. Restoring the stormwater BMP must include removal of sediment and any sediment-laden stormwater BMP soils, and replacing the removed soils with soils meeting the design specification.*
 - b. Prevent compacting infiltration BMPs by excluding construction equipment and foot traffic. Protect completed lawn and landscaped areas from compaction due to construction equipment.*

Stormwater Code Language

- c. Control erosion and avoid introducing sediment from surrounding land uses onto permeable pavements. Do not allow muddy construction equipment on the base material or pavement. Do not allow sediment-laden runoff onto permeable pavements or base materials.*
- d. Permeable pavements fouled with sediments or no longer passing an initial infiltration test must be cleaned until infiltrating per design or replaced.*
- e. Keep all heavy equipment off existing soils under infiltration BMPs, especially those that have been excavated to final grade, to retain the infiltration rate of the soils.*

CHAPTER 4 – Standards and Specifications for Construction Erosion, Sediment, and Flow Control Practices

This chapter contains the standards and specifications for erosion and sediment control practices that form the foundation of erosion and sediment control planning in the City of Seattle (City). These best management practices (BMPs) are grouped according to their method of controlling erosion and sedimentation at project sites:

- Cover Practices (*Section 4.1*)
- Erosion Control Practices (*Section 4.2*)
- Sediment Control Practices (*Section 4.3*)

Refer to these sections for a list of BMPs in each category.

All temporary erosion and sediment control BMPs must be removed within 5 business days after final site stabilization is achieved or after they are no longer needed, whichever is later. In either case, trapped sediment must be removed or stabilized on site and the disturbed areas permanently stabilized.

The standards and specifications for each BMP have been divided into six sections to facilitate the selection process and implementation:

1. Definition
2. Purpose
3. Conditions Where Practice Applies
4. Planning Considerations
5. Design Criteria
6. Maintenance

Note that “Conditions Where Practice Applies” always refers to site conditions. As site conditions change, BMPs must be changed to remain in compliance with the Stormwater Code.

4.1. Cover Practices

The cover BMPs for erosion and sedimentation control are divided into two categories:

1. Temporary cover practices, such as temporary seeding and clear plastic covering (refer to *Section 4.1.1*)
2. Permanent cover practices, such as sodding and planting (refer to *Section 4.1.5*)

The requirements for maintaining permanent BMPs are included with each description; however, all temporary and permanent erosion and sediment control practices should be maintained and repaired as needed to ensure continued performance of their intended function.

4.1.1. *Temporary Cover Practices*

Temporary cover BMPs are implemented to provide a cover to soils exposed during the life of the project. Soil stockpiles must be stabilized from erosion; protected with sediment trapping measures; and where possible, located away from storm drain inlets, waterways, and drainage channels. From October 1 to April 30, no soils should remain exposed and unworked for more than 2 days. From May 1 to September 30, no soils should remain exposed and unworked for more than 7 days.

More than one BMP may be required for effective protection of steeper slopes or where the soils are more erodible.

The standards and specifications for temporary cover BMPs are described in the sections below and include:

- BMP E1.10: Temporary Seeding (*Section 4.1.1.1*)
- BMP E1.15: Mulching, Matting, and Compost Blankets (*Section 4.1.1.2*)
- BMP E1.20: Clear Plastic Covering (*Section 4.1.1.3*)
- Polyacrylamide for soil erosion protection (refer to Washington State Department of Ecology [Ecology] BMP C126)

4.1.1.1. **BMP E1.10: Temporary Seeding**

Description

The establishment of temporary vegetative cover on disturbed areas by seeding with appropriate rapidly growing annual plants.

Purpose

To provide temporary soil stabilization by planting grasses and legumes to areas that would remain bare for more than 7 days where permanent cover is not necessary or appropriate (Figure 1).



Figure 1. Hydroseeding Method.

Conditions Where Practice Applies

- Permanent structures are to be installed or extensive re-grading will occur prior to the establishment of permanent vegetation.
- Areas that will not be subjected to heavy wear by construction traffic.
- Areas sloping up to 15 percent for 100 feet or less (where temporary seeding is the only BMP used).

Planning Considerations

Sheet erosion, caused by the impact of rain on bare soil, is the source of most fine particles in sediment. To reduce this sediment load in runoff, the soil surface itself should be protected. The most efficient and economical means of controlling sheet and rill erosion is to establish vegetative cover. Annual plants that sprout rapidly and survive for only one growing season

are suitable for establishing temporary vegetative cover. Temporary seeding is effective when combined with construction phasing so that bare areas of the site are minimized at all times.

Temporary seeding may prevent costly maintenance operations on other erosion control systems. For example, sediment basin cleanouts will be reduced if the drainage area of a basin is seeded where grading and construction are not taking place. Perimeter dikes will be more effective if not clogged with sediment.

Temporary seeding is essential to preserve the integrity of earthen structures used to control sediment, such as dikes, diversions, and the banks and dams of sediment basins.

Proper seedbed preparation and the use of quality seed are important in this practice just as in permanent seeding. Failure to carefully follow sound agronomic recommendations will often result in an inadequate stand of vegetation that provides little or no erosion control.

Design Criteria

- **Time of Seeding:** Seeding should preferably be done between April 1 and June 30, and September 1 through October 31. If seeding is done in the months of July and August, irrigation will be required until 75 percent grass cover is established. If seeding is done between October 1 and March 31, mulch immediately after seeding.
- **Site Preparation:** Before seeding, install needed surface runoff control measures such as gradient terraces, earth dike or drainage swales, level spreaders, and sediment basins.
- **Seedbed Preparation:** The seedbed should be firm with a fairly fine surface. All soil should be roughened no matter what the slope. If compaction is required for engineering purposes, slopes must be track-walked before seeding. Perform all cultivating operations across or at right angles to the slope. A minimum of 2 to 4 inches of tilled topsoil is required.
- **Fertilization:** Apply fertilizers as per suppliers or Natural Resources Conservation Service (NRCS) recommendations, or apply a 10:4:6 ratio of nitrogen-phosphorus-potassium (N-P-K) fertilizer at a rate of 90 pounds per acre. Developments adjacent to receiving waters must use non-phosphorus fertilizer.
- **Seeding:** Seeding mixtures will vary depending on the exact location, soil type, slope, etc. Information on mixes may be obtained from local suppliers, the Washington State Department of Transportation, or the NRCS. The seed mix in Table 2 is supplied as guidance. Hydroseed applications should include a minimum of 1,500 pounds per acre of mulch with 3 percent tackifier. Refer to City of Seattle Standard Specification 9-14.4(7).
- **Mulching:** Mulch is required for seeding. Mulch can be applied on top of the seed or simultaneously by hydroseeding. Refer to BMP E1.15 Mulching, Matting, and Compost Blankets for more information on mulching.
- **Tackifier:** Apply a tackifier with a tracer to indicate where the seeding has been applied.

Table 2. Temporary Erosion Control Seeding Mixture.^a

Name	Proportion by Weight
Turf-type perennial rye (blend of 3 approved varieties) ^b	50 percent
Creeping red fescue ^b	20 percent
Chewings fescue ^b	20 percent
Hard fescue	10 percent

^a Hydroseeding applications with approved seed-mulch-fertilizer mixtures may also be used. Mixture must be no less than 98 percent pure and have a minimum germination rate of 90 percent.

^b Refer to City of Seattle Standard Specification 9-14.2(1) for approved varieties.

Maintenance

- Seeding should be supplied with adequate moisture. Supply water as needed, especially in abnormally hot or dry weather or on adverse sites. Water application rates should be controlled to prevent runoff.
- Re-seed areas that fail to establish at least 80 percent vegetative cover as soon as such areas are identified. If re-seeding is ineffective, use an alternate method, such as sodding, mulching, or nets or mats.
- If vegetative cover is inadequate to prevent rill erosion, apply other BMPs.

4.1.1.2. BMP E1.15: Mulching, Matting, and Compost Blankets

Description

Application of plant residues or other suitable materials to the soil surface.

Purpose

To provide immediate protection to exposed soils during the period of short construction delays or over winter months through the application of plant residues or other suitable materials to exposed soil areas.

Mulches also enhance plant establishment by conserving moisture and moderating soil temperatures. Mulch helps hold fertilizer, seed, and topsoil in place in the presence of wind, rain, and runoff and maintains moisture near the soil surface.

Conditions Where Practice Applies

- Areas that cannot be seeded because of the season or are otherwise unfavorable for plant growth.
- Areas that have been seeded as specified in Temporary Seeding (BMP E1.10).
- In an area of greater than 25 percent slope, mulching should immediately follow seeding.

Planning Considerations

Mulches are applied to the soil surface to conserve a desirable soil property or to promote plant growth. Surface mulch is one of the most effective means of controlling runoff and erosion on disturbed land (refer to Table 3 for a comparison of pollutant loading reductions for various mulches).

Mulches can increase the infiltration rate of the soil, reduce soil moisture loss by evaporation, prevent crusting and sealing of the soil surface, modify soil temperatures, and provide a suitable microclimate for seed germination.

Organic mulch materials, such as compost, straw, wood chips, bark, and wood fiber, have been found to be the most effective. Compost has the advantage of being reusable by tilling it in to meet the City's soil amendment requirement at the end of the project. A variety of nets and mats have been developed for erosion control in recent years, and these are also used as mulches, particularly in critical areas such as waterways. They may be used to hold other mulches to the soil surface.

The choice of materials for mulching will be based on the type of soil to be protected, site conditions, season, and economics. It is especially important to mulch liberally in mid-summer and prior to winter, and on cut slopes and southern slope exposures.

Table 3. Guide to Mulch Materials, Rates, and Uses.

Mulch Material	Quality Standards	Application Depth	Remarks^a
Gravel, slag, or crushed rock	<ul style="list-style-type: none"> ● Washed ● 0.75 to 1.5 inch size 	3 inches	<ul style="list-style-type: none"> ● Excellent mulch for short slopes and around woody plants and ornamentals. ● Use where subject to foot traffic. Approximately 2,000 pounds per cubic yard.
Straw	<ul style="list-style-type: none"> ● Air dried ● Free from unwanted seeds and coarse material 	Minimum 2 inches	<ul style="list-style-type: none"> ● Use for immediate protection. Hand application generally requires greater thickness than blown straw. ● Thickness of straw may be reduced by half when used in conjunction with seeding. ● Most common and widely used mulching material. Can be used in critical erosion areas.
Wood fiber cellulose (partially digested wood fibers)	<ul style="list-style-type: none"> ● Should not contain growth-inhibiting factors 	Minimum 2 inches	<ul style="list-style-type: none"> ● If used on critical areas, double the normal application rate. ● Apply with a hydro-mulcher with seed and tackifier. No tie-down required. ● Fibers should be less than 0.75 inch and packaged in 100-pound bags. ● Recycled cellulose may contain polychlorinated biphenyls (PCBs); products should be evaluated for PCBs prior to use.
Compost blanket, mulch, and compost	<ul style="list-style-type: none"> ● No visible water or dust during handling 	Minimum 2 inches	<ul style="list-style-type: none"> ● Excellent mulch for protecting final grades until landscaping. ● Can be directly seeded or tilled into soil as an amendment. ● A 3-inch layer provides superior protection.
Chipped site vegetation	<ul style="list-style-type: none"> ● Average size should be several inches ● Gradations from fines to 6 inches 	Minimum 2 inches	<ul style="list-style-type: none"> ● Cost-effective way to dispose of clear and grubbing debris. ● Should not be used on slopes above 10 percent. Not recommended within 200 feet of receiving waters.
Wood-based mulch	<ul style="list-style-type: none"> ● No visible water or dust during handling ● Must be purchased from supplier with Solid Waste Handling Permit (unless exempt) 	Minimum 2 inches	<ul style="list-style-type: none"> ● Often called hog (or hogged) fuel or wood straw and is useful organic matter. ● Typically does not provide any weed seed control. ● Prevent introduction of weed plants or seeds with application.

^a All mulches will provide some degree of (1) erosion control, (2) moisture conservation, (3) weed control, and (4) reduction of soil crusting.

Compost Blankets

Compost for use as a mulch layer (i.e., a compost blanket) should meet the definition of “composted materials,” including contaminant limits, in WAC 173-350---220. Coarsely screened compost (1--inch minus screen) provides superior protection in higher rainfall and on steeper slopes and may be tilled in later for tree and shrub planting areas. A finer compost (1/2-- or 5/8--inch minus screen) may be preferred where it will be tilled in later before planting lawn areas. A 2-inch-thick compost blanket is usually sufficient, but 3 inches provides superior protection.

Compost blankets are a preferred cover practice because they:

- Provide superior ground contact compared to rolled mats.
- Are more effective at filtering both sediment and pollutants such as oil.
- May be seeded when placed and promote superior seed germination.
- Can be reused as compost at the end of the project by tilling it in to soils to meet the City’s Soil Amendment BMP (*Volume 3*).

Chemical Mulches and Soil Binders

The use of synthetic, spray-on materials (except tacking agents used with hydroseeding) is not recommended because they can create impervious surfaces and, possibly, adverse effects on water quality. Research shows they can cause more erosion than bare exposed soil when used.

Nets and Mats

Used alone, netting does not retain soil moisture or modify soil temperature. It stabilizes the soil surface while grasses are being established and is useful in grassed drainage channels and on slopes. Light netting may also be used to hold other mulches in place. Its relatively high cost makes it most suitable for small sites.

The most critical part of installing nets and mats is obtaining firm, continuous contact between material and soil. Without such contact, the material is useless and erosion occurs. It is important to use an adequate number of staples and to roll the material after laying it to ensure soil is protected.

Design Criteria

- Site Preparation – Same as Temporary Seeding (BMP E1.10).
- Mulch Materials, Application Rates, and Specifications – refer to Table 3.
- Erosion nets and mats may be used on level areas, on slopes (Figure 2a) up to 25 percent, and in channels (Figure 2b). Where soil is highly erodible, nets should only be used in connection with organic mulch such as straw and wood fiber. Jute nets should be heavy, uniform cloth woven of single jute yarn and should weigh an average of 1.2 pounds per linear yard if 36 to 48 inches wide. It must be applied so that it is in complete contact with the soil. Netting should be securely anchored to the soil with No. 11 gauge wire staples at least 6 inches long and overlap 2 inches across and 6 inches down.

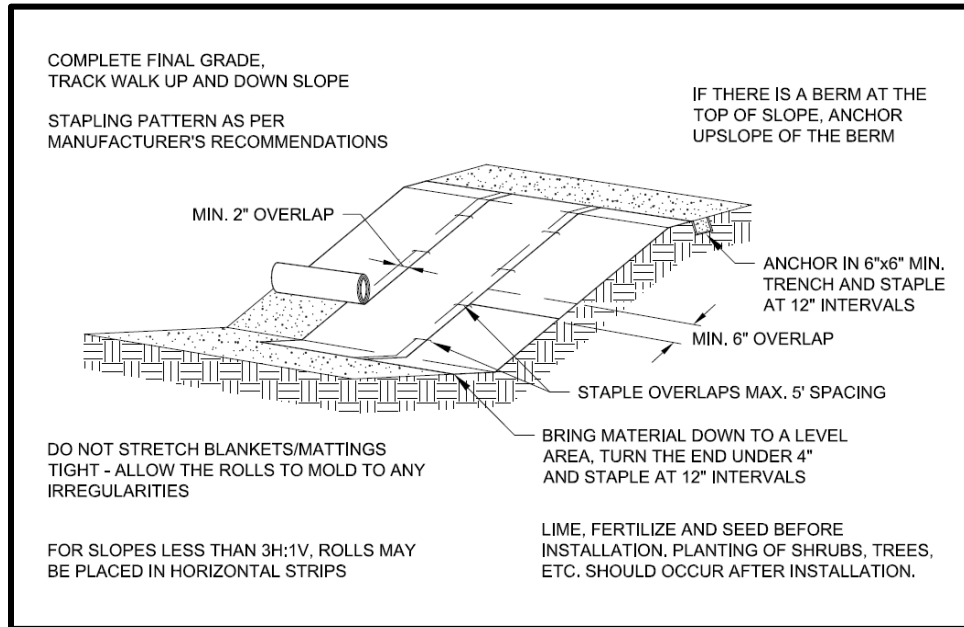

Figure 2a. Mat Installation on Slope.

- To install mats on slopes:
 - First complete the final grade and track walk up and down the slope. Install hydromulch with seed and fertilizer.
 - Dig a small trench, approximately 6 inches wide by 6 inches deep, along the top of the slope.
 - Install the leading edge of the mat into the small trench and staple approximately every 12 inches (metal, U-shaped, and a minimum of 6 inches long). Longer staples should be used in sandy soils. Biodegradable stakes are also available.
 - Roll the mat slowly down the slope as the installer walks backwards, with the mat resting against the installer's legs.
 - Install staples as the mat is unrolled. Do not allow the mat to roll down the slope unattended. Do not allow anyone to walk on the mat after it is in place. If the mat is not long enough to cover the entire slope length, the trailing edge of the upper mat should overlap the leading edge of the lower mat and be stapled.
 - On steeper slopes, this overlap should be installed in a small trench, stapled, and covered with soil.
- Excelsior blankets are considered protective mulches and may be used alone on erodible soils and during all times of year.
- Ecology has also approved technologies that are functionally equivalent to mulching. Refer to the Functionally Equivalent Technologies section of Ecology's TAPE website for approved BMPs: <https://ecology.wa.gov/regulations-permits/guidance-technical-assistance/stormwater-permittee-guidance-resources/emerging-stormwater-treatment-technologies>.

Maintenance

Mulched areas must be checked periodically, especially following severe storms. Damaged areas of mulch or tie-down material must be repaired.

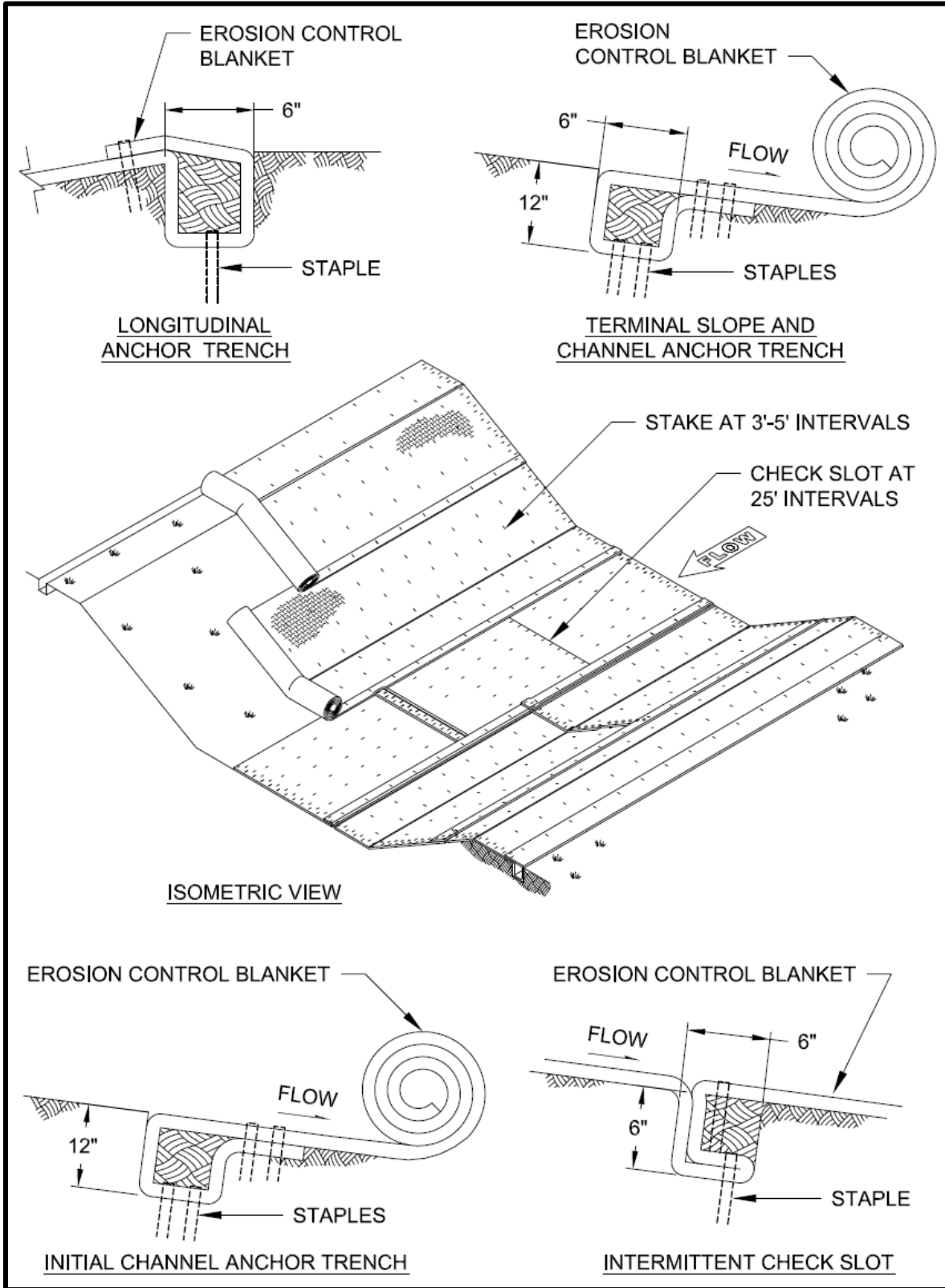

Figure 2b. Mat Installation on a Channel.

4.1.1.3. **BMP E1.20: Clear Plastic Covering**

Description

The covering of bare areas that need immediate protection from erosion with clear plastic sheeting.

Purpose

To provide immediate temporary erosion protection to slopes and disturbed areas that cannot be covered by mulching, to provide protection to plantings during winter, or to cover stockpiles. Clear plastic also is used to protect disturbed areas that must be covered during short periods of inactivity to meet November 1 through March 31 cover requirements. Because of many disadvantages, clear plastic covering is the least preferred cover practice (Figure 3).

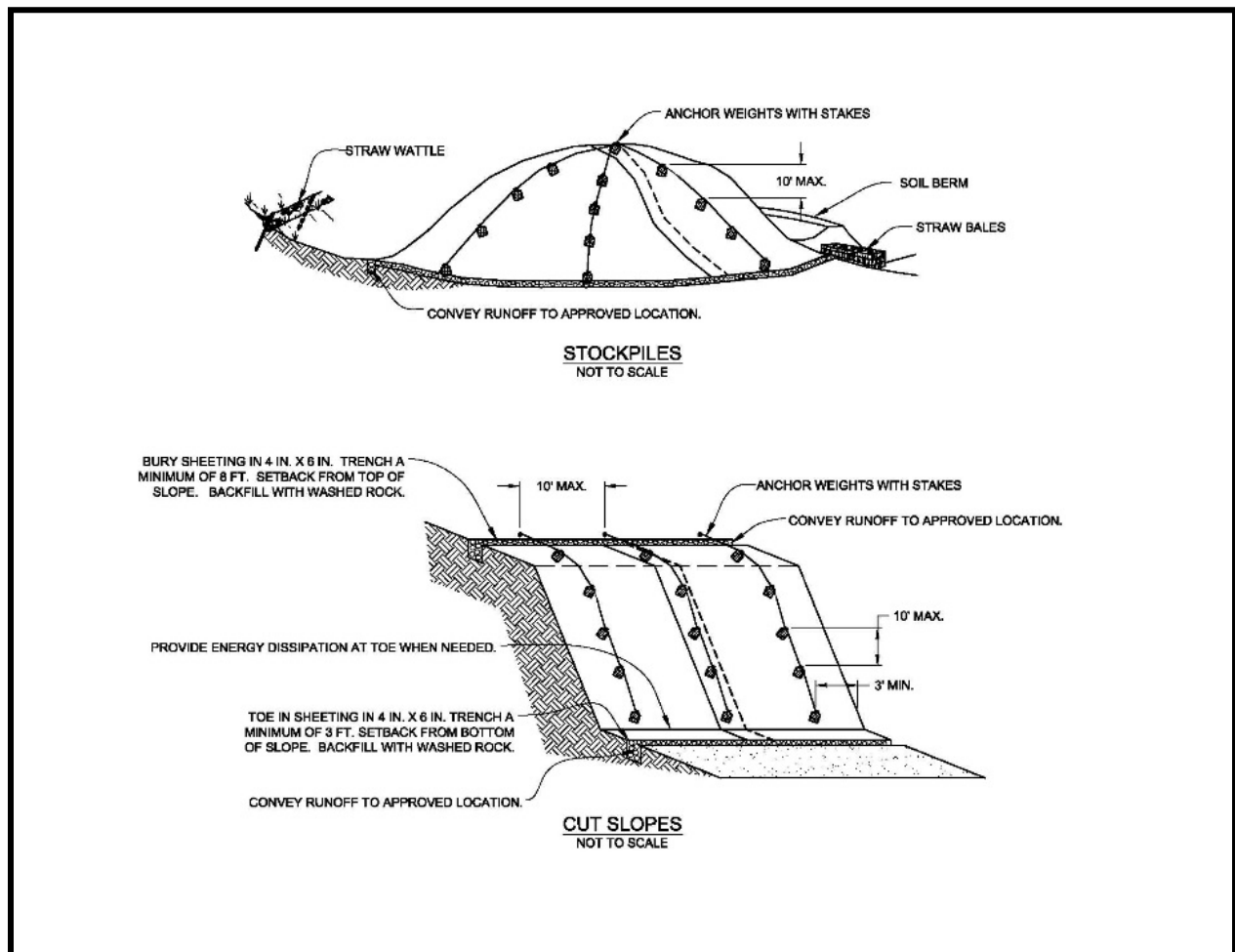

Figure 3. Stockpile Covered with Plastic Sheeting.

Conditions Where Practice Applies

- Disturbed areas that require immediate erosion protection for less than 30 days.
- Areas seeded during the time period from November 1 to March 31.

Planning Considerations

Plantings at this time require clear plastic covering for germination and protection from heavy rains.

Design Criteria

- Clear plastic sheeting must have a minimum thickness of 6 mil and must meet the requirements of the City of Seattle Standard Specifications Section 9-14.5.
- Toe in sheeting by placing plastic into a small (12--inch wide by 6--inch deep) slot trench at the top of the slope and backfill with soil to keep water from flowing underneath the plastic.
- Install covering and maintain tightly in place by using sandbags or tires on ropes with a maximum 10-foot grid spacing in all directions. Tape or weigh down all seams full length with at least a 1- to 2--foot overlap of all seams. Then roll, stake, or tie all seams.
- Immediately install covering on areas seeded between November 1 and March 1, and keep covering in place until vegetation is firmly established.
- When the covering is used on unseeded slopes, leave in place until the next seeding period.
- If erosion at the toe of a slope is likely, install a gravel berm, riprap, or other suitable protection at the toe of the slope in order to reduce the velocity of runoff.
- Remove sheeting as soon as possible once vegetation is well established to prevent burning the vegetation through the plastic sheeting, which acts as a greenhouse.
- Install drainage collection at the toe of the covered slope to collect and route runoff to the approved discharge point, if needed.

Maintenance

Check regularly for rips and places where the plastic may be dislodged. Contact between the plastic and the ground must always be maintained. Any air bubbles found must be removed immediately or the plastic may rip during the next windy period. Re-anchor or replace the plastic as necessary.

4.1.2. Permanent Cover Practices

Permanent cover BMPs are implemented both during and upon completion of construction activities. Permanent cover reduces erosion wherever practical and can be achieved by limiting site disturbance during construction. For example, by preserving existing conifers, approximately 50 percent of all rain that falls onto the trees will be retained during a storm. Up to 20 to 30 percent of this rain may never reach the ground but is taken up by the tree or lost to evaporation. Another benefit of permanent cover is that rain held in permanent vegetation (plantings, grass, trees) can be released slowly into the ground after a rain event.

Note: Equipment access and soil compaction is not allowed in areas where permanent cover is established.

The City requires that all new, replaced, and disturbed topsoil is amended prior to completion of the project. Refer to *Volume 3 – Project Stormwater Control* for guidance on soil amendment BMP requirements.

The standards and specifications for permanent cover BMPs are described below and include:

- BMP E1.30: Preserving Natural Vegetation (*Section 4.1.2.1*)
- BMP E1.35: Buffer Zones (*Section 4.1.2.2*)
- BMP E1.40: Permanent Seeding and Planting (*Section 4.1.2.3*)
- BMP E1.45: Sodding (*Section 4.1.2.4*)
- BMP E1.50: High-Visibility Fence (*Section 4.1.2.5*)

4.1.2.1. BMP E1.30: Preserving Natural Vegetation

Description

Phase construction activities to minimize exposed soils and resulting erosion by clearing only where construction will occur.

Purpose

To reduce erosion by preserving natural vegetation wherever practical (Figure 4).

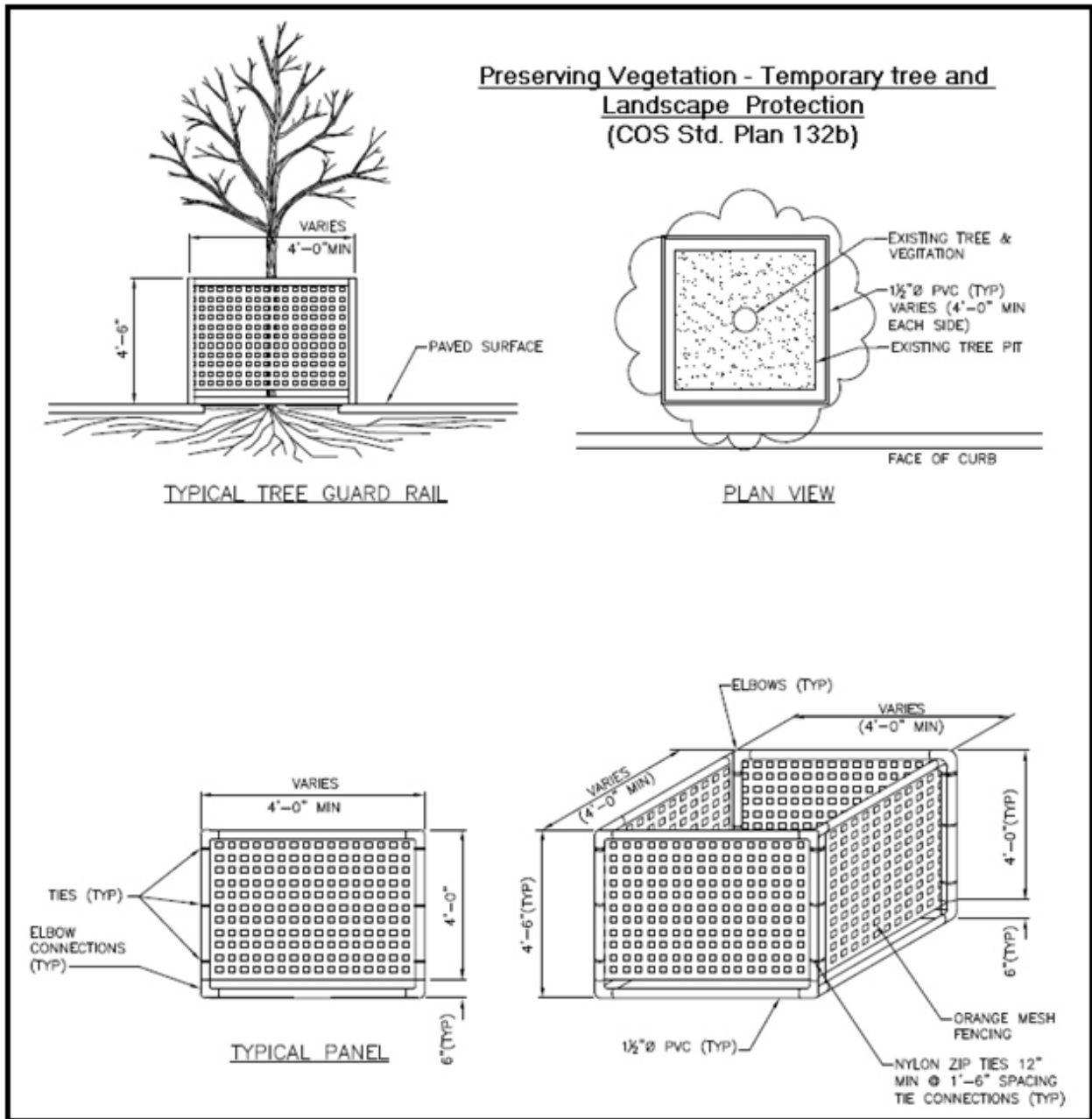

Figure 4. Preserving Vegetation.

Conditions Where Practice Applies

Natural vegetation should be preserved everywhere and must be preserved within certain Environmentally Critical Areas (ECAs) pursuant to SMC, Chapter 25.09. Natural vegetation should be preserved especially on steep slopes, near perennial and intermittent watercourses or swales, and on building sites in wooded areas.

Planning Considerations

Refer to SMC, Section 25.09 Trees and Vegetation and SMC, Section 25.11 Tree Protection for additional requirements for vegetation and tree protection and for requirements within ECAs. See the Seattle Department of Construction and Inspections (SDCI) Trees & Codes website for tree protection requirements on parcels at [https://www.seattle.gov/sdci/codes/codes-we-enforce-\(a-z\)/trees-and-codes#treeprotectionprivateproperty](https://www.seattle.gov/sdci/codes/codes-we-enforce-(a-z)/trees-and-codes#treeprotectionprivateproperty). The Seattle Department of Transportation (SDOT), Urban Forestry section, has additional information regarding general tree and vegetation protection as well as requirements for tree protection in the right-of-way on the City's website (www.seattle.gov/transportation/projects-and-programs/programs/trees-and-landscaping-program).

Design Criteria

It can be worthwhile to preserve natural vegetation both in the form of vegetated communities of trees and related understory plants and in the form of individual trees retained along with the soil that supports them. The preservation of individual trees can be particularly challenging given the typical use of heavy construction equipment on site. Clear field marking is essential to guard against incidental impacts to the soil and or to the trunk, branches, and roots of the tree itself.

Design considerations include:

- Establish a monetary value for the tree or vegetated area and post this in some visible manner on protective fencing to help ensure care on the part of the site contractors. Monetary value is typically established by a professional in the tree care, landscape, or nursery industry. This professional should have value assessment experience in accordance with the 9th Edition of the "Guide for Plant Appraisal" (Council of Tree and Landscape Appraisers 2000). An aspect of appraisal includes application of local standards to help ensure the protection of plants that are desirable native or non-native species.
- Prior to beginning land-disturbing activities, including clearing and grading, clearly mark all clearing limits, critical areas, and their buffers. Clearly flag and provide a rigid (chain link or similar) fence to protect areas around trees and vegetated areas to be retained. In addition, provide high-visibility fencing where required by Section 4.1.5. BMP E1.50. Where protection of all surfaces within the drip line of the tree or vegetated area is not possible, consult a tree care professional with qualifications in urban forestry, landscape architecture, or a related field to develop an appropriate plan. On parcels, the plan must apply the SDCI tree protection requirements. In the right-of-way, the plan must apply the requirements defined in City of Seattle Standard Plans 132a, 132b and 133.
- The duff layer, native topsoil, and natural vegetation should be retained in an undisturbed state to the maximum degree practical.

- Trees and other plants need protection from three types of impacts:
 - Construction Equipment: Impacts from construction equipment can occur above or below the ground level. Damage results from scarring, cutting of roots, and compaction of the soil. Roping or fencing a buffer zone around plants to be saved can prevent such injuries.
 - Grade Change: Any grade change affecting areas within the drip line of an existing tree should be reviewed and approved by a tree care professional with local construction experience. Local experience is needed to ensure familiarity with the tree species and local conditions associated with soil, drainage, and pests or disease that may be factors. Where appropriate, systems may be designed utilizing structural or engineered soil mixes and/or “rootways” to ensure the circulation of air to roots impacted by fill.
 - Excavation: Excavation within the drip line of trees commonly requires exploratory work utilizing hand equipment, including the use of an air spade to fracture soil and reveal root locations without damage. Identifying the location of existing roots allows construction to occur within areas where roots are expected with minimal damage to critical root systems.
- For trees required to be preserved, any activities within the drip line requires oversight by a certified arborist or professional. For specific information about preserving mature trees and/or large plants, refer to references listed on the Seattle Department of Construction and Inspections (SDCI) Tree and Landscaping Guidance and Requirements web page ([www.seattle.gov/sdci/codes/codes-we-enforce-\(a-z\)/tree-protection-code](http://www.seattle.gov/sdci/codes/codes-we-enforce-(a-z)/tree-protection-code)).
- In all situations involving vegetation preservation, it is fundamentally important to involve a qualified tree or vegetation care professional to assess the specific site issues. The above guidelines are designed to capture the major common issues associated with vegetation preservation; however, each site will be unique and would benefit from the input of a dedicated professional.

Maintenance

Inspect tree and protection areas regularly to make sure fencing has not been removed. If the fencing has been damaged, repair or replace immediately. If tree roots have been exposed or injured, “prune” cleanly with an appropriate pruning saw or loppers directly above the damaged roots and re-cover with native soils (with arborist oversight). Mechanical treatment of sap-flowing trees (i.e., fir, hemlock, pine, soft maples) is not advised as sap forms a natural healing barrier.

4.1.2.2. **BMP E1.35: Buffer Zones**

Description

An undisturbed area or strip of natural vegetation or an established suitable planting that will provide a living filter to reduce soil erosion and stormwater runoff velocities.

Purpose

Buffer zones are used along streams and other receiving waters that need protection from erosion and sedimentation (Figure 5).



Figure 5. Vegetated Buffer Zone.

Conditions Where Practice Applies

Contractors can use vegetative buffer zone BMPs to protect natural swales, and they can incorporate them into the natural landscaping of an area. Do not use critical area buffer zones as sediment treatment areas; these areas should remain completely undisturbed.

Planning Considerations

The City's ECA regulations require undisturbed vegetative buffer zones for wetlands (SMC, Section 25.09.160), steep slope areas (SMC, Section 25.09.090), and fish and wildlife habitat

conservation areas (SMC, Section 25.09.200). Refer to the appropriate code section(s) for site-specific requirements.

Design Criteria

- Preserve natural vegetation or plantings in clumps, blocks, or strips. This is generally the easiest and most successful method.
- Leave all critical areas in a naturally vegetative condition.
- Fence clearing limits and keep all equipment and construction debris out of the natural vegetation.
- Keep all excavations outside of critical areas and the drip line of trees and shrubs.
- Do not push debris or extra soil into the buffer zone area because it will cause damage to vegetation from burying and smothering.

Maintenance

Inspect the area frequently to make sure flagging remains in place and the area remains undisturbed.

4.1.2.3. **BMP E1.40: Permanent Seeding and Planting**

Description

The establishment of perennial vegetative cover on disturbed areas.

Purpose

- To establish permanent vegetation (i.e., grasses, legumes, trees, and shrubs) as rapidly as possible to prevent soil erosion by wind or water and to improve wildlife habitat and site aesthetics.
- To provide pollutant filtration (biofiltration) in vegetation-lined channels and to establish constructed wetlands as required.

Conditions Where Practice Applies

- Graded, final graded, or cleared areas where permanent vegetative cover is needed to stabilize the soil.
- Areas that will not be brought to final grade for 1 year or more.
- Vegetation-lined channels.
- Retention or detention ponds as required.

Planning Considerations

Vegetation controls erosion by reducing the velocity and the volume of overland flow and protecting the bare soil surface from raindrop impact.

Land that has been disturbed requires vegetative cover. The most common and economical means of establishing this cover is by seeding grasses and legumes.

Advantages of seeding over other means of establishing plants include the small initial establishment cost, the wide variety of grasses and legumes available, low labor requirement, and ease of establishment in difficult areas.

Disadvantages that must be dealt with are the potential for erosion during the establishment stage, a need to reseed areas that fail to establish, limited periods during the year suitable for seeding, and a need for water and appropriate climatic conditions during germination.

Consider the microclimate(s) within the development area. Low areas may have frost pockets and require hardier vegetation because cold air tends to sink and flow toward low spots. South-facing slopes may be more difficult to re-vegetate because they tend to be sunnier and drier.

There are so many variables in plant growth that an end product cannot be guaranteed. Much can be done in the planning stages to increase the chances for successful seeding. Selection of the right plant materials for the site, good seedbed preparation, timing, and conscientious maintenance are important. Whenever possible, native species of plants should be used for landscaping. These plants are already adapted to the area and survivability should be higher than with exotic species.

Native species are also less likely to require irrigation. Irrigation can require extensive maintenance, is not cost-effective, and is not an ecologically sound practice.

Design Criteria

- Vegetation cannot be expected to supply an erosion control cover and prevent slippage on a soil that is not stable due to its texture, structure, water movement, or excessive slope.
- Seeding should be done immediately after final shaping, except during the period of November 1 through March 1 when the site should be protected by mulching or plastic covering until the next seeding period. Seeding completed between July 1 and August 30 will require irrigation until 75 percent grass cover is established.
- Permanent vegetation may be in the form of grass-type growth by seeding or sodding, or it may be trees or shrubs, or a combination of these. Establishing this cover may require the use of supplemental materials, such as mulch or jute netting (refer to BMP E1.15).
- Prepare the site by installing temporary surface runoff control measures prior to seeding or planting to protect the surface from erosion until the vegetation is established. Temporary measures include gradient terraces, berms, dikes, level spreaders, drainage channels, and sediment basins.
- Soil amendments should be used to achieve organic matter and permeability performance defined in engineered soil and landscape systems. Compost used should meet City of Seattle Standard Specifications 9-14.4(5) or 9-14.4(8). Refer to *Volume 3 – Project Stormwater Control, Section 5.1* for additional requirements regarding soil amendments.
- Prepare seedbed for seeding of grasses and legumes. If infertile or coarse textured subsoil will be exposed during land shaping, it is best to stockpile topsoil and re-spread it over the finished slope at a minimum 2-- to 6--inch depth and roll it to provide a firm seedbed. If construction fills have left soil exposed with a loose, rough, or irregular surface, smooth with blade and roll. If cuts or construction equipment have left a tightly compacted surface, break with chisel plow or other suitable implement. Perform all cultivating operations across or at right angles to the slope (contoured), such as with cat tracks on the final pass. The seedbed should be firm with a fairly fine surface. All soil should be roughened before seeding. If compaction is required for engineering purposes, slopes must be track walked before seeding.
- Apply an appropriate seed mixture to the prepared seedbed at a rate of 120 pounds per acre. The erosion seeding mixture for application is presented in Table 4.

Table 4. Permanent Seeding Mixture.^a

Name	Percent by Weight
Turf-type perennial rye ^b	50 percent
Creeping red fescue ^b	20 percent
Chewings fescue ^b	20 percent
Hard fescue	10 percent

Notes:

^a Hydroseeding applications with approved seed-mulch-fertilizer mixtures may also be used. Mixture must be no less than 98 percent pure and have a minimum germination rate of 90 percent.

^b Refer to City of Seattle Standard Specification 9-14.2(1) for approved varieties.

- Cover the seed with topsoil or mulch no deeper than 0.5 inch. It is better to work topsoil into the upper soil layer rather than spread a layer of it directly on top of the native soil.
- “Hydroseeding” applications with approved seed-mulch-fertilizer mixtures may also be used. Hydroseed applications should include a minimum of 1,500 pounds per acre of mulch with 3 percent tackifier.
- Mulch is always required for seeding. Mulch can be applied on top of the seed or simultaneously by hydroseeding.
- Seeding and planting should be supplied with adequate moisture. Supply water as needed. Water application rates should be controlled to prevent runoff.
- Re-seed and re-plant any areas that fail to establish at least 80 percent cover or experience erosion.
- Control erosion in areas with other BMPs, such as mulching, netting, or matting as necessary to prevent soil loss.
- A wetlands specialist should design plantings and seed mixtures for newly created wetlands to provide the best chance of success. Refer to *Volume 3 – Project Stormwater Control* for more information on constructed wetlands.
- Noxious weeds such as reed canary grass (*Phalaris arundinacea*) or purple loosestrife (*Lythrum salicaria*) are not allowed.
- Trees and shrubs provide natural beauty and wildlife benefits in addition to their erosion and sediment control values. When used for beauty and wildlife benefits, they are usually more effective when planted in clumps or blocks. These procedures should be followed:
 - Trees and shrubs will do best in topsoil. If no topsoil is available, they can be established in subsoil with proper amendment. If trees and shrubs are to be planted in subsoil, particular attention should be paid to amending the soil with generous amounts of organic matter. Mulches should also be used.
 - Good quality planting stock should be used. Normally, 1-to 2--year-old deciduous seedlings, and 3-to 4--year-old coniferous transplants, when properly produced and handled, are adequate. Stock should be kept cool and moist from time of receipt and planted as soon as possible.
 - Competing vegetation, if significant, should be pulled out of the area where the plant or plants are to be placed.

Maintenance

Inspect seeded areas for failure, make necessary repairs, and re-seed areas with less than 80 percent cover immediately. Conduct a follow-up survey after 1 year and replace failed plants where necessary.

- If vegetative cover is inadequate to prevent rill erosion, apply other BMPs, assuming vegetation was successful.
- If a stand has less than 40 percent cover, re-evaluate choice of plant materials and quantities of lime and fertilizer. Re-establish the stand following recommendations for seedbed preparation and seeding, omitting lime and fertilizer in the absence of soil test results. If the season prevents re-sowing, mulch or jute netting is an effective temporary cover.

4.1.2.4. **BMP E1.45: Sodding**

Description

The stabilizing of fine-graded disturbed areas by establishing permanent grass stands with sod.

Purpose

To establish permanent turf for immediate erosion protection or to stabilize drainage channels where concentrated overland flow will occur.

Conditions Where Practice Applies

- Disturbed areas that require immediate vegetative cover.
- Drainage channels carrying intermittent flow where immediate stabilization or aesthetics are factors and other locations particularly suited to stabilization with sod.

Planning Considerations

Sod can initially be more costly than seeding, but the advantages often justify the increased initial costs. Sod provides immediate erosion control and a green surface; however, it must be protected from disturbance while it takes root. Sod is preferable to seed due to the following:

- Reduced failure, as compared to seed, and the lack of weeds.
- Can be established nearly year-round.
- Immediate protection of the drainage channel after application.

Design Criteria

- Shape and smooth the surface to final grade in accordance with the approved grading plan. Over excavate the swale 4 to 6 inches below design elevation to allow room for placing soil amendment and sod.
- Soil amendments should be used to achieve organic matter and permeability performance defined in engineered soil and landscape systems. Compost used should meet City of Seattle Standard Specifications 9-14.4(5) or 9-14.4(8) for Grade A quality compost. Refer to *Volume 3, Section 5.1* for additional requirements regarding soil amendments.
- Add lime to reach a soil pH value of 6.5 (based on soil tests).
- Fertilize according to a soil test or in the absence of a test use available nitrogen, phosphorus, and potash as prescribed for permanent seeding. Use fertilizers that are not highly soluble.
- Work lime and fertilizer into the soil 1 to 2 inches deep and smooth the surface.
- Lay strips of sod beginning at the lowest area to be sodded and perpendicular to the direction of water flow. Wedge strips securely in place. Square the ends of each strip to provide for a close, tight fit. Stagger joints at least 12 inches. Staple the upstream edge of each sod strip if installed on slopes steeper than 18 percent.
- Roll the sodded area and irrigate.
- When sodding is carried out in alternating strips or other patterns, seed the areas between the sod immediately after sodding.

- Sod should be free of weeds and be of uniform thickness (approximately 1 inch) and should have a dense root mat for mechanical strength.

Maintenance

Inspect sodded areas regularly, especially after large storm events. Re-tack, re-sod, or re-seed and protect with a net or mat as necessary.

4.1.2.5. **BMP E1.50: High-Visibility Fence**

Description

Limit access to portions of the site not undergoing construction.

Purpose

Fencing is intended to:

- Restrict clearing to approved limits.
- Prevent disturbance of sensitive areas, their buffers, and other areas required to be left undisturbed.
- Limit construction traffic to designated construction entrances, exits, or internal roads.
- Protect areas where marking with survey tape may not provide adequate protection.

Conditions Where Practice Applies

High-visibility fence is required:

- to establish clearing and grading limits at the boundary of sensitive areas, their buffers, and other areas required to be left uncleared or undisturbed. It is also recommended to establish clearing limits and grading limits in general
- necessary to control vehicle access to and on the site

Design Criteria

- High-visibility plastic fence should be composed of a high-density polyethylene material and should be at least 4 feet in height. Posts for the fencing should be steel or wood and placed every 6 feet on center (maximum) or as needed to ensure rigidity. The fencing should be fastened to the post every 6 inches with a polyethylene tie. On long continuous lengths of fencing, a tension wire or rope should be used as a top stringer to prevent sagging between posts. The fence color should be high-visibility orange. The fence tensile strength should be 360 pounds per foot using the ASTM D4595 testing method.
- If appropriate, install fabric filter fence in accordance with BMP E3.10 to act as a high-visibility fence. Filter fence should be at least 3 feet high and must be highly visible to meet the requirements of this BMP.
- Metal fences must be designed and installed according to the manufacturer's specifications.
- Metal fences should be at least 3 feet high and must be highly visible.
- Fences must not be wired or stapled to trees.

Maintenance

If the fence has been damaged or visibility reduced, it must be repaired or replaced immediately and visibility restored.

4.2. Erosion Control Practices

Naturally occurring (undisturbed) soil and vegetation provide important stormwater management functions, including:

- Water infiltration
- Nutrient, sediment, and pollutant adsorption
- Sediment and pollutant biofiltration
- Water interflow storage and transmission
- Pollutant decomposition

These functions are largely lost when construction practices erode native soil and vegetation.

This section presents BMPs that temporarily and permanently address erosion, including measures for project site stabilization, slope protection, and drainage channel protection. The BMPs in this section have been divided into three basic groups based on these characteristics:

1. Temporary erosion control practices, such as road stabilization, check dams, and dust control (beginning at *Section 4.2.1*).
2. Permanent erosion control practices, such as gradient terraces and riprap channel lining (refer to Ecology's *Stormwater Management Manual for Western Washington [SWMMWW]*).
3. Temporary or permanent erosion control practices, such as subsurface drains, earth dikes and drainage swales, and outlet protection (beginning at *Section 4.2.3*).

The requirements for maintaining permanent erosion control BMPs are included with each description; however, all temporary and permanent erosion and sediment control practices should be maintained and repaired as needed to ensure continued performance of their intended function.

The City requires that all new, replaced, and disturbed topsoil is amended prior to completion of the project. Refer to *Volume 3 – Project Stormwater Control Section 5.1* for guidance on soil amendment requirements.

Permanent erosion control BMPs may need to be designed by an engineer and may have additional criteria for flow and water quality treatment requirements. Variations or alterations to the minimum BMP requirements typically require an engineer's approval. Refer to *Volume 1* for thresholds and standards.

4.2.1. *Temporary Erosion Control BMPs*

Although temporary erosion control BMPs are emphasized in this section, they may be combined with permanent control facilities to provide protection of downstream properties during construction. Temporary facilities provide siltation control, but downstream erosion protection must also be provided. Refer to *Volume 3 – Project Stormwater Control* for flow control requirements.

Temporary cover BMPs are described in the sections below and include:

- BMP E2.10: Stabilized Construction Access (*Section 4.2.1.1*)
- BMP E2.15: Tire Wash (*Section 4.2.1.2*)
- BMP E2.20: Construction Road Stabilization (*Section 4.2.1.3*)
- BMP E2.35: Check Dams (*Section 4.2.1.4*)
- BMP E2.40: Triangular Silt Dike (Geotextile-encased Check Dam) (*Section 4.2.1.5*)
- BMP E2.45: Dust Control (*Section 4.2.1.6*)
- Level Spreader – refer to *Appendix E*
- Water Bars – refer to Ecology BMP C203

4.2.1.1. **BMP E2.10: Stabilized Construction Access**

Description

A temporary rock-stabilized pad located at all points of vehicular entrance and exit on a construction project or site.

Purpose

To reduce the amount of mud, dirt, rocks, etc. transported onto public roads by motor vehicles or runoff by constructing a stabilized pad of rock spalls at entrances to and exits from project sites and washing of tires during egress (Figure 6 and Figure 7).



Figure 6. Stabilized Construction Access.



Figure 7. Stabilized Construction Access.

Conditions Where Practice Applies

Whenever traffic leaves a project site and moves onto a public road or other paved area. Also refer to BMP E3.70 Street Sweeping and Vacuuming.

Planning Considerations

Construction entrances and exits provide an area where mud can be removed from vehicle tires before they enter a public road. Construction entrances and exits should be used in conjunction with the stabilization of construction roads to reduce the amount of mud picked up by vehicles. Construction vehicle entrance and exit should be limited to one route, if possible.

It is important to note that this BMP will only be effective if sediment control is used throughout the rest of the project site.

Design Criteria

- A geotextile should be placed under the spalls to prevent fine sediment from pumping up into the rock pad. The geotextile should meet the standards presented in City of Seattle Standard Specification 9--37.

- Material should be quarry spalls (where possible), 4 to 8 inches in size. Do not use crushed concrete, recycled concrete, cement, or calcium chloride for construction access stabilization, because these products raise pH levels in stormwater runoff.
- Alternative materials to quarry spalls may be used with increased offsite inspections. For an alternative specification used by the Washington State Department of Transportation (WSDOT), refer to BMP C105 Stabilized Construction Access in Volume II of the SWMMWW.
- The rock pad should be at least 12 inches thick and 100 feet in length for sites more than 1 acre and may be reduced to the maximum practical size when the size or configuration of the site does not allow the full 100-foot length.
- The access width should be the full width of the vehicle entrance and exit area.
- Additional rock should be added periodically to maintain proper function of the pad.
- Fencing should be installed as necessary to restrict traffic to the construction access.
- Whenever possible, the access point should be constructed on level ground with a firm, compacted subgrade. This can substantially increase the effectiveness of the pad and reduce the need for maintenance.
- Ecology has also approved technologies that are functionally equivalent to stabilized construction access. Refer to the Functionally Equivalent Technologies section of Ecology's TAPE website for approved BMPs (<https://ecology.wa.gov/regulations-permits/guidance-technical-assistance/stormwater-permittee-guidance-resources/emerging-stormwater-treatment-technologies>).

Maintenance

- If the access point is not preventing sediment from being tracked onto pavement, then alternative measures are required to keep the streets free of sediment. This may include an increase in the dimensions of the entrance or the installation of a tire wash (BMP E2.15). Until the entrance is functioning properly, street sweeping may be required.
- Maintain the access point in a condition that will prevent tracking or flow of mud onto public rights-of-way. This may require periodic top dressing with 2--inch rock, as conditions demand, and repair, cleanout, or both, of any structures used to trap sediment. Thoroughly clean all materials spilled, dropped, washed, or tracked from vehicles onto roadways at the end of each day or more frequently during wet weather.
- Remove any sediment that is tracked onto pavement by shoveling or street sweeping. Remove or stabilize onsite sediment collected by sweeping.
- Street washing is allowed only after sediment is removed in accordance with the previous bullet. Do not allow street washwater to enter the public drainage system or systems tributary to waters of the state. All street washwater must be collected and discharged either back onto the site or into the sanitary sewer (if permitted).
- Immediately remove any quarry spalls loosened from the pad that end up on the roadway or sidewalk.

4.2.1.2. **BMP E2.15: Tire Wash**

Description

A system that uses water to wash motor vehicle tires and is located at exit points from a project site.

Purpose

A tire wash is used to remove mud, dirt, rocks, etc. from tires and under carriages, and to prevent sediment from being transported onto public roads.

Conditions Where Practice Applies

When a stabilized construction entrance or exit (refer to BMP E2.10) is not preventing sediment from being tracked onto pavement.

Planning Considerations

If approval by King County for wastewater discharge to the sanitary or combined sewer is not obtained, process wastewater can be collected and taken off site to an approved location. Indicate the ultimate discharge point or collection point on the Construction Stormwater Control and Soil Management Plan sheet that clearly identifies the location(s) of stormwater discharges.

Tire washes provide an area where mud can be removed from vehicle tires before they enter a public road. Tire washes and construction entrance points should be used in conjunction with the stabilization of construction roads to reduce the amount of mud picked up by vehicles.

It is important to note that this BMP will only be effective if sediment control is used throughout the rest of the project site.

Design Criteria

- Suggested details are shown in Figure 8. A minimum of 6 inches of asphalt-treated base (ATB) over crushed base material or 8 inches over a good subgrade is recommended to pave the tire wash.
- Use a low clearance truck to test the tire wash before paving. Either a belly dump or lowboy will work well to test clearance.
- Keep the water level from 12 to 14 inches deep to avoid damage to truck hubs and filling the truck tongues with water.
- Midpoint spray nozzles are only needed in extremely muddy conditions.
- Tire wash systems should be designed with a small change in grade—6 to 12 inches for a 10-foot wide pond—to allow sediment to flow to the low side of the pond to help prevent re-suspension of sediment. A drain pipe with a 2- to 3-foot riser should be installed on the low side of the pond to allow for easy cleaning and refilling. Polymers may be used to promote coagulation and flocculation in a closed-loop system. Refer to Ecology BMP C126 for additional information on polyacrylamide (PAM) polymers.

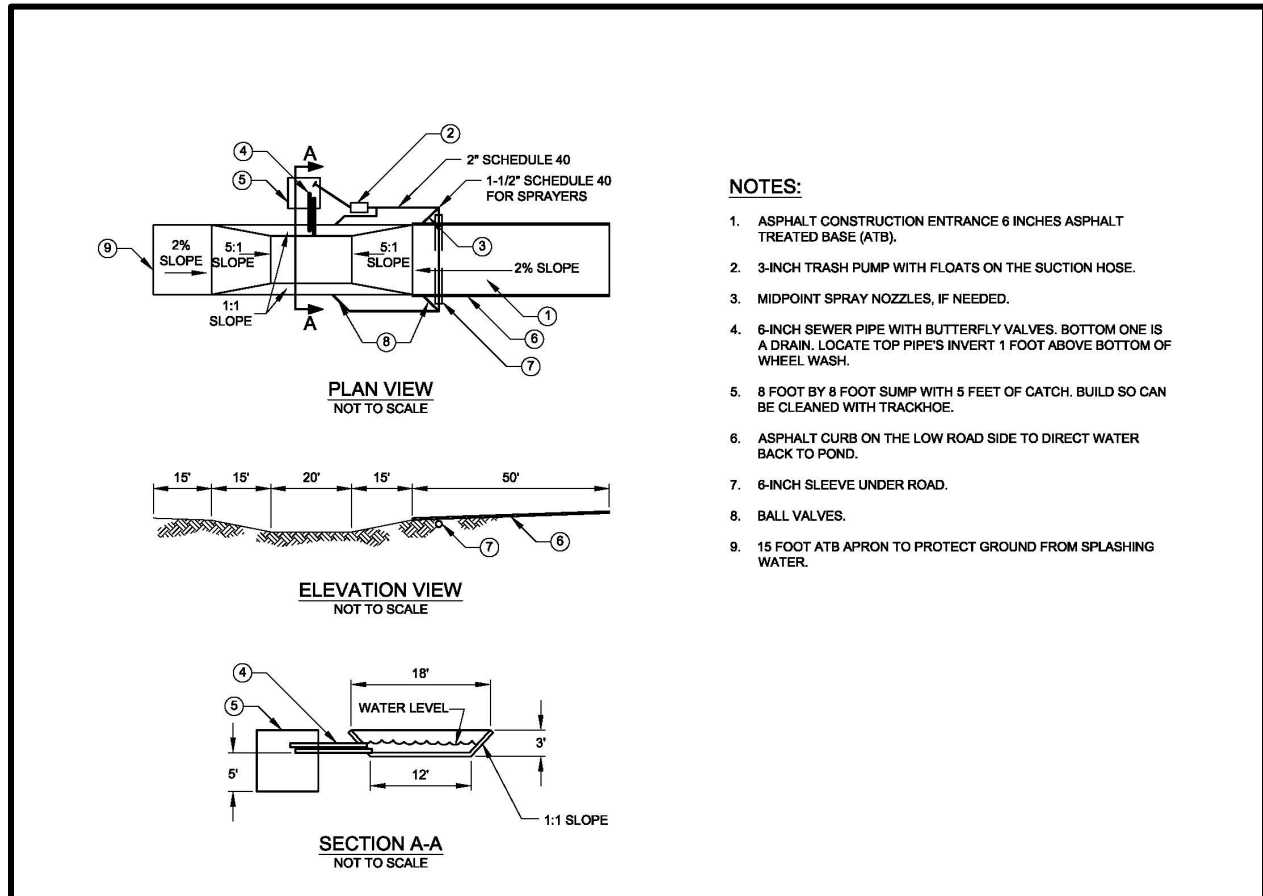

Figure 8. Tire Wash Details.

- Ecology has also approved technologies that are functionally equivalent to tire wash. Refer to the Functionally Equivalent Technologies section of Ecology's TAPE website for approved BMPs (<https://ecology.wa.gov/regulations-permits/guidance-technical-assistance/stormwater-permittee-guidance-resources/emerging-stormwater-treatment-technologies>).

Maintenance

- The washwater should be changed a minimum of once per day. On large earthwork jobs where more than 10 to 20 trucks per hour are expected, the washwater will need to be changed more often.
- Wheel wash or tire bath wastewater should be discharged to a separate onsite treatment system that prevents discharge to receiving waters, such as closed-loop recirculation or upland land application, or to the sanitary sewer with prior approval by King County.

4.2.1.3. **BMP E2.20: Construction Road Stabilization**

Description

The temporary stabilization with rock on access roads, subdivision roads, parking areas, and other onsite vehicle transportation routes immediately after grading.

Purpose

- To reduce erosion of temporary roadbeds by construction traffic during wet weather.
- To reduce the erosion and therefore re-grading of permanent roadbeds between the time of initial grading and final stabilization.
- To minimize the amount of dirt tracked off site by vehicular traffic.

Conditions Where Practice Applies

Wherever rock-base roads or parking areas are constructed, whether permanent or temporary, for use by construction traffic.

Planning Considerations

Areas graded for construction vehicle transport and parking purposes are especially susceptible to erosion. The exposed soil surface is continually disturbed, leaving no opportunity for vegetative stabilization. Such areas also tend to collect and transport runoff waters along their surfaces. During wet weather, they often become muddy quagmires that generate significant quantities of sediment that may pollute nearby streams or be transported off site on the wheels of construction vehicles. Dirt roads can become so unstable during wet weather that they are virtually unusable.

Immediate stabilization of such areas with rock may cost money at the outset, but it may actually save money in the long run by increasing the usefulness of the road during wet weather.

Permanent roads and parking areas should be paved as soon as possible after grading. As an alternative, the early application of rock may solve potential erosion and stability problems and eliminate later re-grading costs. Some of the rock will also likely remain in place for use as part of the final base course of the road.

Design Criteria

- Immediately after grading or the completion of utility installation within the right-of-way, apply a 6--inch course of 2- to 4--inch crushed rock, gravel base, or crushed surfacing base course. A 4--inch course of asphalt-treated base (ATB) may be used in lieu of the crushed rock.
- Temporary roads should not exceed 15 percent, should minimize cuts in existing slopes, and be carefully graded to drain crosswise. Provide drainage swales to carry flow to a sediment control BMP (*Section 4.3*).
- Protect installed inlets to prevent sediment-laden water from entering the drain sewer system (refer to BMP E3.25).
- Maintain undisturbed buffer areas at all stream crossings.

- Seed, mulch, or cover areas adjacent to culvert crossings and steep slopes.
- Use dust control when necessary (refer to BMP E2.45).
- If the stabilized construction access does not adequately reduce the amount of tracked material, install one or more tire wash BMPs (refer to BMP E2.15).
- Install fencing to limit the access of vehicles to only those roads and parking areas that are stabilized.

Maintenance

- Inspect stabilized areas regularly, especially after large storm events. Add crushed rock if necessary and re-stabilize any areas found to be eroding.

4.2.1.4. **BMP E2.35: Check Dams**

Description

Small dams constructed across a swale or drainage ditch.

Purpose

To reduce the effective slope of the channel and, therefore, the velocity of concentrated flows; reduce erosion of the swale or ditch; and slow water velocity to allow retention of sediments.

Conditions Where Practice Applies

Where temporary channels or permanent channels are not yet vegetated or riprap channel lining is infeasible and, therefore, velocity checks are required. Check dams should be placed at regular intervals within constructed channels that are cut down a slope.

Planning Considerations

The City's ECA regulations require protection for high flow refuge habitat for overwintering juvenile salmonids and emergent salmonid fry. Check dams cannot be placed below the expected backwater from any of these areas during specific times of the year. Refer to SMC 25.09 for site-specific requirements.

No check dams may be placed in streams (unless approved by the Washington Department of Fish and Wildlife as appropriate). Other permits may also be necessary.

Check dams can be constructed of either rock or gravel-filled sandbags. If rock check dams are used in grass-lined channels that will be mowed, care should be taken to remove all the rock from the channel when the dam is removed. This should include any rock that has washed downstream.

Design Criteria

- Check dams can be constructed of rock or pea-gravel-filled bags. Where high velocity flow is not a concern, compost socks may be used. If necessary, compost socks may be stacked.
- Place check dams perpendicular to the flow of water.
- The dam should form a triangle when viewed from the side. This prevents undercutting as water flows over the face of the dam rather than falling directly onto the ditch bottom.
- Before installing check dams, impound and bypass upstream flow away from the work area. Options for bypassing include pumps, siphons, or temporary channels.
- Check dams in association with sumps work more effectively at slowing flow and retaining sediment than just a check dam alone. Provide a deep sump immediately upstream of the check dam.
- In some cases, if carefully located and designed, check dams can remain as permanent installations with very minor re-grading. They may be left as either spillways—in which case accumulated sediment would be graded and seeded—or as check dams to prevent further sediment from leaving the site.

- Keep the maximum spacing between the dams such that the toe of the upstream dam is at the same elevation as the top of the downstream dam (Figure 9).

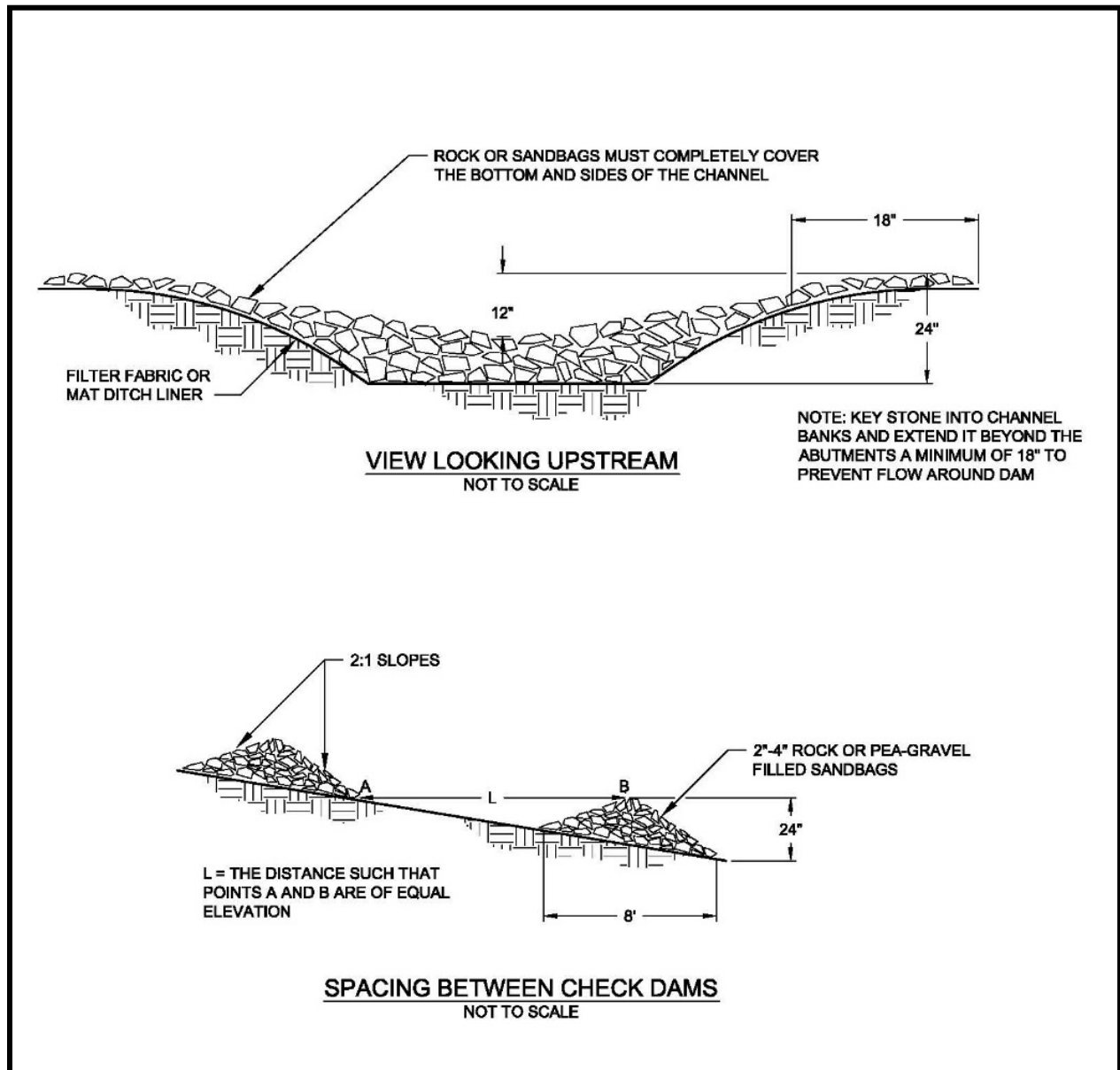

Figure 9. Check Dams.

- Keep the maximum height at 2 feet at the center of the dam.
- Keep the center of the check dam at least 12 inches lower than the outer edges at natural ground elevation.
- Keep the side slopes of the check dam at 2H:1V or flatter.
- Key the rock into the ditch banks and extend it beyond the abutments a minimum of 18 inches to avoid washouts from overflow around the dam.
- Rock check dams should be constructed of appropriately sized rock. The rock used must be large enough to stay in place given the expected design flow through the

channel. Place the rock by hand or by mechanical placement (no dumping of rock to form dam) to achieve complete coverage of the ditch or swale and to ensure that the center of the dam is lower than the edges.

- Use filter fabric foundation under a rock or sandbag check dam. This is not necessary if a mat ditch liner is used. A piece of organic or synthetic mat cut to fit will also work for this purpose.
- In the case of grass-lined ditches and swales, remove check dams when the grass has matured sufficiently to protect the ditch or swale, unless the slope of the swale is greater than 4 percent. Immediately after dam removal, seed and mulch the area beneath the check dams.
- Ensure that channel appurtenances, such as culvert entrances below check dams, are not subject to damage or blockage from displaced rocks.
- Ecology has also approved technologies that are functionally equivalent to check dams. Refer to the Functionally Equivalent Technologies section of Ecology's TAPE website for approved BMPs: <https://ecology.wa.gov/regulations-permits/guidance-technical-assistance/stormwater-permittee-guidance-resources/emerging-stormwater-treatment-technologies>.

Maintenance

- Monitor check dams for performance and sediment accumulation during and after each runoff-producing rainfall. Remove sediment when it reaches one-half the sump depth.
- If significant erosion occurs between dams, install a protective riprap liner in that portion of the channel.

4.2.1.5. **BMP E2.40: Triangular Silt Dike (TSD)**

Description

A triangular dike made of urethane foam sewn into a woven geosynthetic fabric.

Purpose

TSDs may be used as check dams, perimeter protection, temporary soil stockpile protection, drop inlet protection, or as a temporary earth dike (Figure 10).

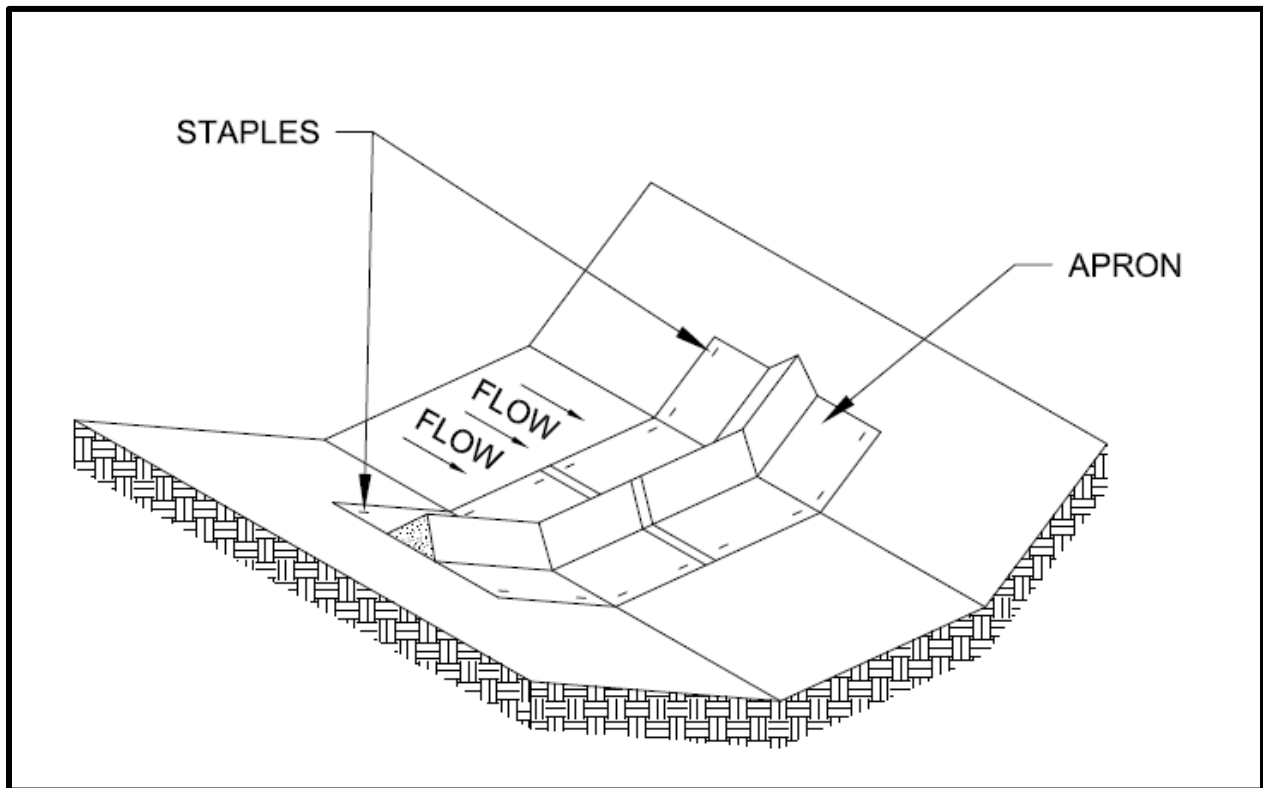

Figure 10. Triangular Silt Dike Cut Section.

Conditions Where Practice Applies

- May be used as temporary check dams in ditches of any dimension.
- May be used on soil or pavement with adhesive or staples.
- TSDs have been used to build temporary:
 - Sediment ponds
 - Diversion ditches
 - Concrete washout facilities
 - Curbing
 - Water bars
 - Level spreaders
 - Berms

Planning Considerations

- When used as check dams:
 - TSDs should be located and installed as soon as construction will allow.
 - TSDs should be placed perpendicular to the flow of water.
 - Anticipate submergence and deposition above the TSD and erosion from high flows around the edges of the dam.

Design Criteria

This BMP is typically made of urethane foam sewn into a woven geosynthetic fabric. It is triangular, 10 inches to 14 inches high in the center, with a 20- to 28-inch base. A 2-foot apron extends beyond both sides of the triangle along its standard section of 7 feet. A sleeve at one end allows attachment of additional sections as needed.

- Install with ends curved up to prevent water from flowing around the ends.
- The fabric flaps and check dam units are attached to the ground with wire staples. Wire staples should be No. 11 gauge wire and should be 200 millimeters (mm) to 300 mm in length.
- When multiple units are installed, the sleeve of fabric at the end of the unit should overlap the abutting unit and be stapled.
- When used as check dams, secure the leading edge with rocks, sandbags, or a small key slot and staples.
- Ecology has also approved technologies that are functionally equivalent to triangular silt dikes. Refer to the Functionally Equivalent Technologies section of Ecology's TAPE website for approved BMPs: <https://ecology.wa.gov/regulations-permits/guidance-technical-assistance/stormwater-permittee-guidance-resources/emerging-stormwater-treatment-technologies>.

Maintenance

- Inspect TSDs for performance and sediment accumulation during and after each runoff-producing rainfall. Remove sediment when it reaches one-half the height of the TSD.
- In the case of grass-lined ditches and swales, remove check dams and accumulated sediment when the grass has matured sufficiently to protect the ditch or swale, unless the slope of the swale is greater than 4 percent. Seed and mulch the area beneath the check dams immediately after dam removal.
- Immediately repair any damage or any undercutting of the TSD.

4.2.1.6. **BMP E2.45: Dust Control**

Description

Reducing surface and air movement of dust during land-disturbing, demolition, and construction activities.

Purpose

To prevent surface and air movement of dust from exposed soil surfaces onto roadways, adjoining properties, and into drainage channels and receiving waters (Figure 11).



Figure 11. Using a Water Truck for Dust Control.

Conditions Where Practice Applies

In areas (including roadways) subject to surface and air movement of dust where onsite and offsite damage is likely to occur if preventive measures are not taken.

Planning Considerations

Research at project sites has established an average dust emission rate of 1.2 tons/acre/month for active construction.

Construction activities result in the exposure and disturbance of soil. Fugitive dust is emitted both during the activities (i.e., excavation, demolition, vehicle traffic, human activity) and as a result of wind erosion over the exposed earth surfaces. Large quantities of dust are typically generated by “heavy” construction activities, such as road and street construction, and subdivision, commercial, and industrial development, which involve disturbance of significant areas of soil surface. Earthmoving activities are the major source, but traffic and general disturbance of the soil also generate significant dust emissions.

In planning for dust control, remember that the less soil is exposed at any one time, the less potential there will be for dust generation. Therefore, phasing a project and using temporary

stabilization practices upon the completion of grading can significantly reduce dust emissions. Also, limit traffic on areas off the site roadways.

Design Criteria

- Minimize the period of soil exposure through use of temporary ground cover and other temporary stabilization practices (refer to Seeding and Mulching, BMPs E1.10 and E1.15, respectively).
- Construct natural or artificial windbreaks or windscreens. These may be designed as enclosures for small dust sources.
- Sprinkle the site with water until surface is wet. Repeat as needed. To prevent carryout of mud onto street, refer to Stabilized Construction Access (BMP E2.10) and Tire Wash (BMP E2.15).
- Spray exposed soil areas with approved dust palliative. Oil should not be used for dust suppression. Refer to Ecology BMP C250 for information on chemical treatment.
- Building demolition should use sufficient water, such as from a hydrant or water truck(s), to thoroughly wet buildings and debris for dust suppression, and control for water runoff from the site. Repeat as needed. To prevent carryout of mud onto the street, refer to Stabilized Construction Access (BMP E2.10) and Tire Wash (BMP E2.15).

Maintenance

Re-spray area as necessary to keep dust to a minimum.

4.2.2. Permanent Erosion Control BMPs

Permanent erosion control BMPs are implemented both during and upon completion of construction activities. Permanent erosion control reduces erosion wherever practical and can be achieved primarily by installing permanent stabilizing structures or materials to new construction or existing sites. For example, by adding gradient terraces to an existing or newly constructed slope, erosion will be significantly reduced by creating a set of ridges and channels that intercept runoff and direct it to a controlled outlet. The benefit is that rill and gully formation will be minimized and toe of slope erosion will decrease as a result. Another benefit of permanent erosion control is that some of the following BMPs include using vegetation, which may be incorporated into permanent cover BMPs described in *Section 4.1.2*.

Permanent erosion control BMPs should be designed by an engineer and may have additional criteria for flow control and water quality treatment requirements. Refer to *Volume 3 – Project Stormwater Control*.

The standards and specifications for permanent erosion control BMPs include:

- Riprap Channel Lining – refer to Ecology BMP C202
- Gradient Terracing – refer to Ecology BMP C131

4.2.3. Temporary or Permanent Erosion Control BMPs

There is a subset of erosion control BMPs that may be used as temporary controls during construction, then remain as a permanent erosion control measure. For example, an earth dike and drainage swale would provide siltation control during construction and remain as permanent protection of downstream properties after construction.

Temporary measures that may also remain as a permanent erosion control are typically implemented during construction activities.

The BMPs in this section include:

- BMP E2.70: Subsurface Drains (*Section 4.2.2.2*)
- BMP E2.80: Earth Dike and Drainage Swale (*Section 4.2.3.2*)
- Outlet Protection – refer to *Appendix E*
- Pipe Slope Drains – refer to *Appendix E*
- Surface Roughening – refer to Ecology BMP C130
- Grass-lined Channels – refer to Ecology BMP C201

The requirements for maintaining permanent BMPs are included with each description; however, all temporary and permanent erosion and sediment control practices should be maintained and repaired as needed to ensure continued performance of their intended function.

4.2.3.1. **BMP E2.70: Subsurface Drains**

Description

A perforated conduit such as a pipe, tubing, or tile installed beneath the ground to intercept and convey groundwater.

Purpose

To provide a dewatering mechanism for draining excessively wet, sloping soils that usually consists of an underground-perforated pipe that will intercept and convey groundwater.

Conditions When Practice Applies

Wherever excessive water must be removed from the soil. The soil must be deep and permeable enough to allow an effective system to be installed. This standard does not apply to subsurface drains for building foundations or deep excavations.

Planning Considerations

Subsurface drainage systems are of two types: relief drains and interceptor drains. Relief drains are used either to lower the water table in order to improve the growth of vegetation or to remove ponded water. They are installed along a slope and drain in the direction of the slope. They can be installed in a gridiron pattern, a herringbone pattern, or a random pattern.

Interceptor drains are used to remove water as it seeps down a slope to prevent the soil from becoming saturated and subject to slippage. They are installed across a slope and drain to the side of the slope. They usually consist of a single pipe or series of single pipes instead of a patterned layout.

Design Criteria

- Temporary measures that may also remain as permanent erosion control are typically implemented during construction activities. The depth of an interceptor drain is determined primarily by the depth to which the water table is to be lowered or the depth to a confining layer. For practical reasons, the maximum depth is usually limited to 6 feet with a minimum cover of 2 feet to protect the conduit.
- The soil should be deep enough and have sufficient permeability to permit installation of an effective drainage system at a depth of 2 to 6 feet.
- An adequate outlet for the drainage system must be available either by gravity or by pumping.
- The quantity and quality of discharge needs to consider the ultimate receiving water (additional detention and/or treatment may be required).
- The capacity of an interceptor drain is determined by calculating the maximum rate of groundwater flow to be intercepted. Therefore, it is good practice to make completed subsurface investigations, including hydraulic conductivity of the soil, before designing a subsurface drainage system.
- Subsurface drains are sized for the required capacity without pressure flow. The minimum diameter for a subsurface drain is 4 inches.

- The minimum velocity required to prevent silting is 1.4 feet per second (ft/sec). Grade the line to achieve at least this velocity. The maximum allowable velocity using a sand-gravel filter or envelope is 9 feet per second.
- Use filter material and fabric around all drains for proper bedding and filtration of fine materials. Envelopes and filters should surround the drain to a minimum thickness of 3--inches.
- Install the outlet of the subsurface drain such that it empties into a sediment trap or pond. If free of sediment, it can empty into a receiving water, swale, or stable vegetated area adequately protected from erosion and undermining.
- The strength and durability of the pipe must meet the requirements of the site in accordance with the manufacturer's specifications.
- Secure an animal guard to the outlet end of the pipe to keep out rodents.
- Use outlet pipe of corrugated metal, cast iron, or heavy-duty plastic without perforations that is at least 10 feet long. Do not use an envelope or filter material around the outlet pipe and bury at least two-thirds of the pipe length.
- When outlet velocities exceed those allowable for the receiving water, provide outlet protection.

Construction Specifications

- Construct the trench on a continuous grade with no reverse grades or low spots.
- Stabilize soft or yielding soils under the drain with gravel or other suitable material.
- Do not use deformed, warped, or otherwise unsuitable pipe.
- Place filter material as specified with at least 3 inches of material on all sides of the pipe.
- Backfill immediately after placement of the pipe. Do not allow sections of pipe to remain uncovered overnight or during a rainstorm. Place backfill material in the trench in such a manner that the drain pipe is not displaced or damaged.

Maintenance

- Periodically check subsurface drains to ensure they are free-flowing and not clogged with sediment.
- Keep the outlet clean and free of debris.
- Keep surface inlets open and free of sediment and other debris.
- Trees located too close to a subsurface drain often clog the system with their roots. If a drain becomes clogged, relocate the drain to minimize this problem. As a last resort, the trees may need to be removed. Tree removal may require prior approval by SDCI and SDOT.
- Where heavy vehicles cross drains, check the line to ensure that it is not crushed.

4.2.3.2. BMP E2.80: Earth Dike and Drainage Swale

Description

A ridge of compacted soil or a swale with vegetative lining located at the top or base of a sloping disturbed area.

Purpose

To intercept stormwater runoff from drainage areas above unprotected slopes and direct it to a stabilized outlet.

Conditions Where Practice Applies

Wherever the volume and velocity of runoff from exposed or disturbed slopes must be reduced. When an earth dike or drainage swale is placed above a disturbed slope, it reduces the volume of water reaching the disturbed area by intercepting runoff from above (Figure 12). When it is placed horizontally across a disturbed slope, it reduces the velocity of runoff flowing down the slope by reducing the distance that the runoff can flow directly downhill.

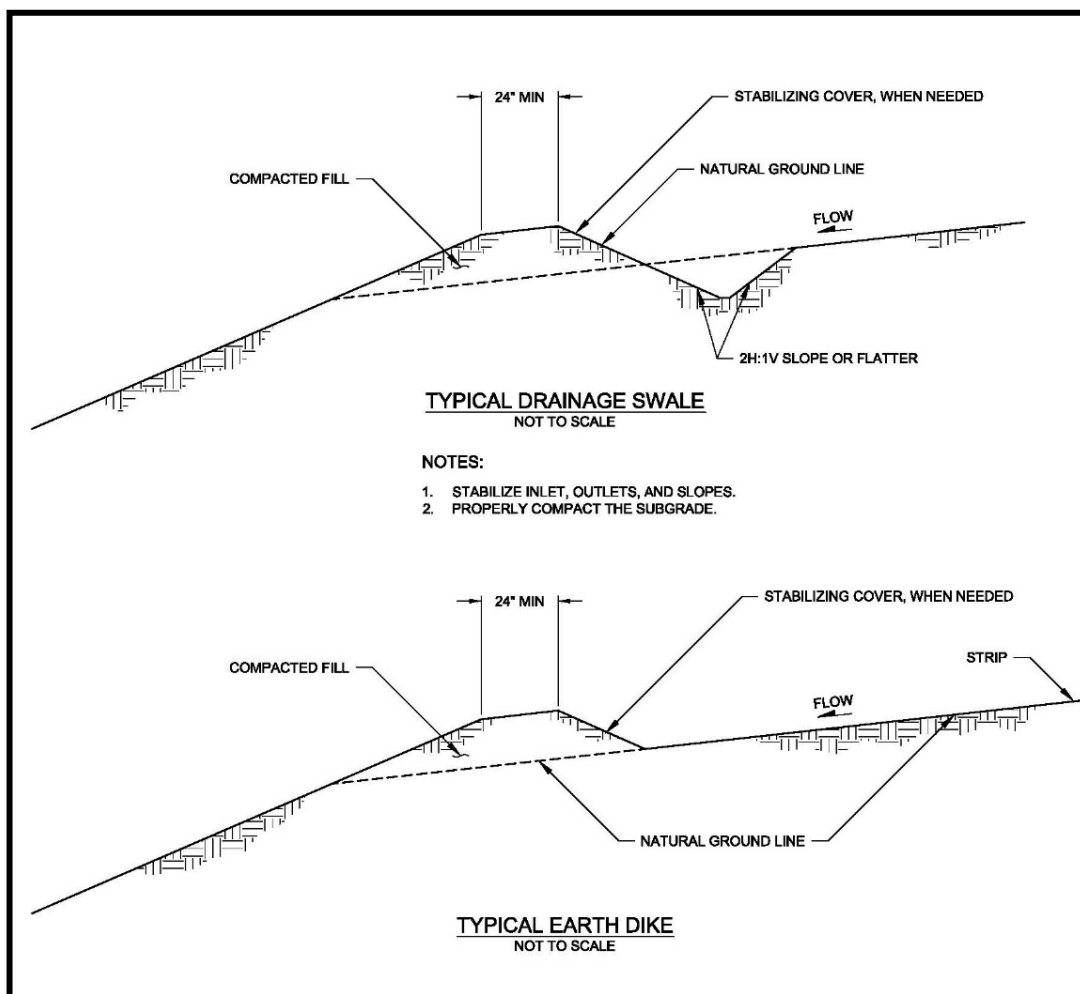

Figure 12. Earth Dike and Drainage Swale.

Planning Considerations

A temporary diversion dike or swale is intended to divert overland sheet flow to a stabilized outlet or a sediment trapping facility during establishment of permanent stabilization on a sloping disturbed area. When used at the top of a slope, the structure protects exposed slopes by keeping upland runoff away. When used at the base of a slope, the structure protects adjacent and downstream areas by diverting sediment-laden runoff to a sediment trapping facility.

If the dike or swale is going to remain in place for longer than 15 days, it must be stabilized with temporary or permanent vegetation. The slope behind the dike or swale is also an important consideration. The dike or swale must have a positive grade to ensure drainage, but if the slope is too great, precautions, including channel protection and check dams, must be taken to prevent erosion due to high velocity of flow.

This practice is considered an economical one because it uses material available on the site and can usually be constructed with equipment needed for site grading. Stabilizing the dike or swale with vegetation can extend the useful life of the BMP.

Design Criteria

- Temporary measures that may also remain as permanent erosion control are typically implemented during construction activities. Review construction for areas where overtopping may occur.
- Subbasin tributary area should be 1 acre or less.
- Earth dikes must meet the criteria in Table 5.
- Drainage swales must meet the criteria in Table 6.
- An 8- or 12-inch diameter compost sock may also be used.
- Design the dike or swale to contain flows calculated by one of the following methods:
 - Single Event Hydrograph Method: The peak flow rate from a 10--year, 24--hour frequency storm with a 10--minute time step.
 - Continuous Simulation Method: The 10--year peak flow rate as determined by an approved continuous runoff model with a 15--minute time step or less.

Maintenance

Inspect the measure after every major storm and make repairs as necessary. Repair damage caused by construction traffic or other activity before the end of each working day.

Table 5. Design Criteria for Earth Dike.

Feature	Requirement
Top Width	2-foot minimum.
Height	18-inch minimum measured from upslope toe and at a compaction of 90 percent ASTM D698 standard proctor.
Side Slopes	25 percent or flatter.
Grade	Topography dependent, except that the dike should be limited to grades between 0.5 and 1.0 percent.
Horizontal Spacing of Earth Dikes	<ul style="list-style-type: none"> • Slopes less than 5 percent = 300 feet • Slopes 5–10 percent = 200 feet • Slopes 10–40 percent = 100 feet
Stabilization	<ul style="list-style-type: none"> • Slopes = less than 5 percent. Seed and mulched construction (refer to BMPs E1.10 and E1.15). • Slopes = 5 to 40 percent. Dependent on runoff velocities and dike materials. • Stabilization should be done immediately using either sod or riprap to avoid erosion.
Outlet	The upslope side of the dike should provide positive drainage to the dike outlet. No erosion should occur at the outlet. Provide energy dissipation measures as necessary. Sediment-laden runoff must be released through a sediment trapping facility.
Other	Minimize construction traffic over temporary dikes.

Table 6. Design Criteria for Drainage Swale.

Feature	Requirement
Bottom Width	2-foot minimum. Bottom should be level.
Depth	1-foot minimum.
Side Slopes	25 percent or flatter.
Grade	5 percent maximum with positive drainage to suitable outlet such as a sediment trap.
Stabilization	Seed as per BMP E1.10 temporary seeding or Ecology BMP C130. Riprap 12 inches thick pressed into bank and extending at least 8 inches vertical from the bottom.
Stabilization	Slope of disturbed area: Less than 5 percent = 300 feet 5–10 percent = 200 feet 10–40 percent = 100 feet
Outlet	Level spreader or riprap to stabilized outlet or sedimentation pond.

4.3. Sediment Control Practices

Sediment retention practices for construction activities are temporary controls only. Permanent sediment retention requires a separate process for flow control and treatment facilities as outlined in *Volume 3 – Project Stormwater Control*.

Temporary sediment retention BMPs are described in the sections below and include:

- BMP E3.10: Filter Fence (*Section 4.3.1*)
- BMP E3.20: Gravel Filter Berm (*Section 4.3.2*)
- BMP E3.25: Inlet Protection (*Section 4.3.3*)
- BMP E3.30: Vegetated Strip (*Section 4.3.4*)
- BMP E3.35: Straw Wattles, Compost Socks, and Compost Berms (*Section 4.3.5*)
- BMP E3.40: Sediment Trap (*Section 4.3.6*)
- BMP E3.50: Portable Sediment Tank (*Section 4.3.7*)
- BMP E3.60: Construction Stormwater Filtration (*Section 4.3.8*)
- BMP E3.65: Cleaning Inlets and Catch Basins (*Section 4.3.9*)
- BMP E3.70: Street Sweeping and Vacuuming (*Section 4.3.10*)
- Brush Barrier – refer to Ecology BMP C231
- Sediment Pond (Temporary) – refer to Ecology BMP C241
- Construction Stormwater Chemical Treatment – refer to Ecology BMP C250

The requirements for maintaining these BMPs are included with each description. All temporary sediment retention practices should be maintained and repaired as needed to ensure continued performance of their intended function.

Temporary BMPs must be removed within 5 business days after final site stabilization is achieved, or after they are no longer needed, whichever is later. In either case, trapped sediment must be removed or stabilized on site and the disturbed areas permanently stabilized.

4.3.1. *BMP E3.10: Filter Fence*

Description

A temporary sediment barrier consisting of a filter fabric stretched across and attached to supporting posts and entrenched. The filter fence is constructed of stakes and synthetic filter fabric with a rigid wire fence backing where necessary for support.

Purpose

Filter fence is used during construction operations to intercept and detain small amounts of sediment under sheet flow conditions from disturbed areas in order to prevent sediment from leaving the site and to decrease the velocity of sheet flows (Figure 13).



Figure 13. Filter Fence Installed on a Slope.

Conditions Where Practice Applies

Filter fence may be used downslope of all disturbed areas and must be provided just upstream of the point(s) of runoff discharge from a site before the flow becomes concentrated. They may also be used below disturbed areas where runoff may occur in the form of sheet and rill erosion, and wherever runoff has the potential to impact downstream resources.

Planning Considerations

Laboratory work at the Virginia Highway and Transportation Research Council has shown that filter fence can trap a much higher percentage of suspended sediments than can straw bales, which have been disallowed by Ecology. The fence must be properly installed to fully function. The installation methods outlined here can improve performance.

Design Criteria

Refer to Figure 14 for design details.

- The drainage area must be 1 acre or less. On larger sites, the fence must be used in combination with sediment basin(s).
- Maximum slope steepness on the site (perpendicular to fence line) is 45 percent.
- Maximum sheet or overland flow path length to the fence is 100 feet.
- Concentrated flows must not be greater than 0.5 cubic feet per second (cfs).
- Selection of a filter fabric is based on soil conditions at the project site. Soil conditions affect the apparent opening size (AOS) fabric specification. Soils also affect the characteristics of the support fence, which depend on the choice of tensile strength. The designer should specify a filter fabric that retains the soil found on the project site yet will have openings large enough to permit drainage and prevent clogging. Refer to Table 7 for selection of the AOS.
- The material used in a filter fabric fence must have sufficient strength to withstand various stress conditions. The ability to pass flow through must be balanced with the material's ability to trap sediments.
- Support non-woven and regular strength slit film fabrics with wire mesh, chicken wire, 2-inch x 2-inch wire, safety fence, or jute mesh to increase the strength of the fabric. Filter fence materials are available that have synthetic mesh backing attached.
- Filter fabric material must contain ultraviolet ray inhibitors and stabilizers to provide a minimum of 6 months of expected usable construction life at a temperature range of 0°F to 120°F.
- One hundred percent biodegradable filter fence is available that is strong, long lasting, and can be left in place after the project is completed.
- The following design criteria must be used with a Large Project Construction Stormwater Control and Soil Management Plan (*Section 2.2*):
 - Purchase filter fabric in a continuous roll cut to the length of the barrier to avoid use of joints. When joints are necessary, splice filter cloth together only at a support post, with a minimum 6-inch overlap. Securely fasten both ends to the post.
 - Space posts a maximum of 6 feet apart and drive securely into the ground a minimum of 30 inches (where physically possible).
 - Excavate a trench approximately 8 inches wide and 12 inches deep along the line of posts and upslope from the barrier. Construct the trench to follow the contour.
 - When slit film filter fabric is used, fasten a wire mesh support fence securely to the upslope side of the posts using heavy-duty wire staples at least 1-inch long, tie

- wires, or hog rings. Extend the wire into the trench a minimum of 4 inches and not more than 36 inches above the original ground surface.
- Wire the slit film filter fabric to the fence. Extend 20 inches of the fabric into the trench. Extend the fabric not more than 36 inches above the original ground surface. Filter fabric should not be stapled to existing trees. Other types of fabric may be stapled to the fence.
- When extra-strength or monofilament fabric and closer post spacing are used, the wire mesh support fence may be eliminated. In this case, staple or wire the filter fabric directly to the posts. Use extra care when joining or overlapping these stiffer fabrics.
- Use properly compacted native material. This is the preferred alternative because the soil forms a more continuous contact with the trench below, and use of native materials reduces the number of trips that must be made on and off site.
- Remove filter fabric fences when they have served their useful purpose but not before the upslope area has been permanently stabilized. Remove retained sediment and properly dispose of or mulch and seed.

Table 7. Geotextile Standards.

Geotextile Property	Test Method	Geotextile Property Requirements
Polymeric Mesh AOS	ASTM D4751	0.60 mm max. for slit film woven (#30 sieve) 0.30 mm max. for all other geotextile types (#50 sieve) 0.15 mm min. for all fabric types (#100 sieve)
Water Permittivity	ASTM D4491	0.02 sec-1 min.
Grab Tensile Strength	ASTM D4632	180 lbs. min. for extra strength fabric 100 lbs min. for standard strength fabric
Grab Tensile Strength	ASTM D4632	30% max.
Ultraviolet Resistance	ASTM D4355	70% min.

- Ecology has also approved technologies that are functionally equivalent to filter fences. Refer to the Functionally Equivalent Technologies section of Ecology's TAPE website for approved BMPs: <https://ecology.wa.gov/regulations-permits/guidance-technical-assistance/stormwater-permittee-guidance-resources/emerging-stormwater-treatment-technologies>.

Maintenance

- Inspect immediately after each rainfall and at least daily during prolonged rainfall. Repair as necessary.
- Remove sediment when it reaches approximately one-third the height of the fence.
- Spread any sediment deposits remaining in place after the filter fence is no longer required to conform to the existing grade and prepare and seed.
- Repair any damage immediately.
- Intercept and convey all evident concentrated flows uphill of the filter fence to a sediment pond.
- Check the uphill side of the fence for signs of the fence clogging and acting as a barrier to flow and causing channelization of flows parallel to the fence. If this occurs, replace the fence or remove the trapped sediment.

- Replace filter fabric that has deteriorated due to ultraviolet breakdown.

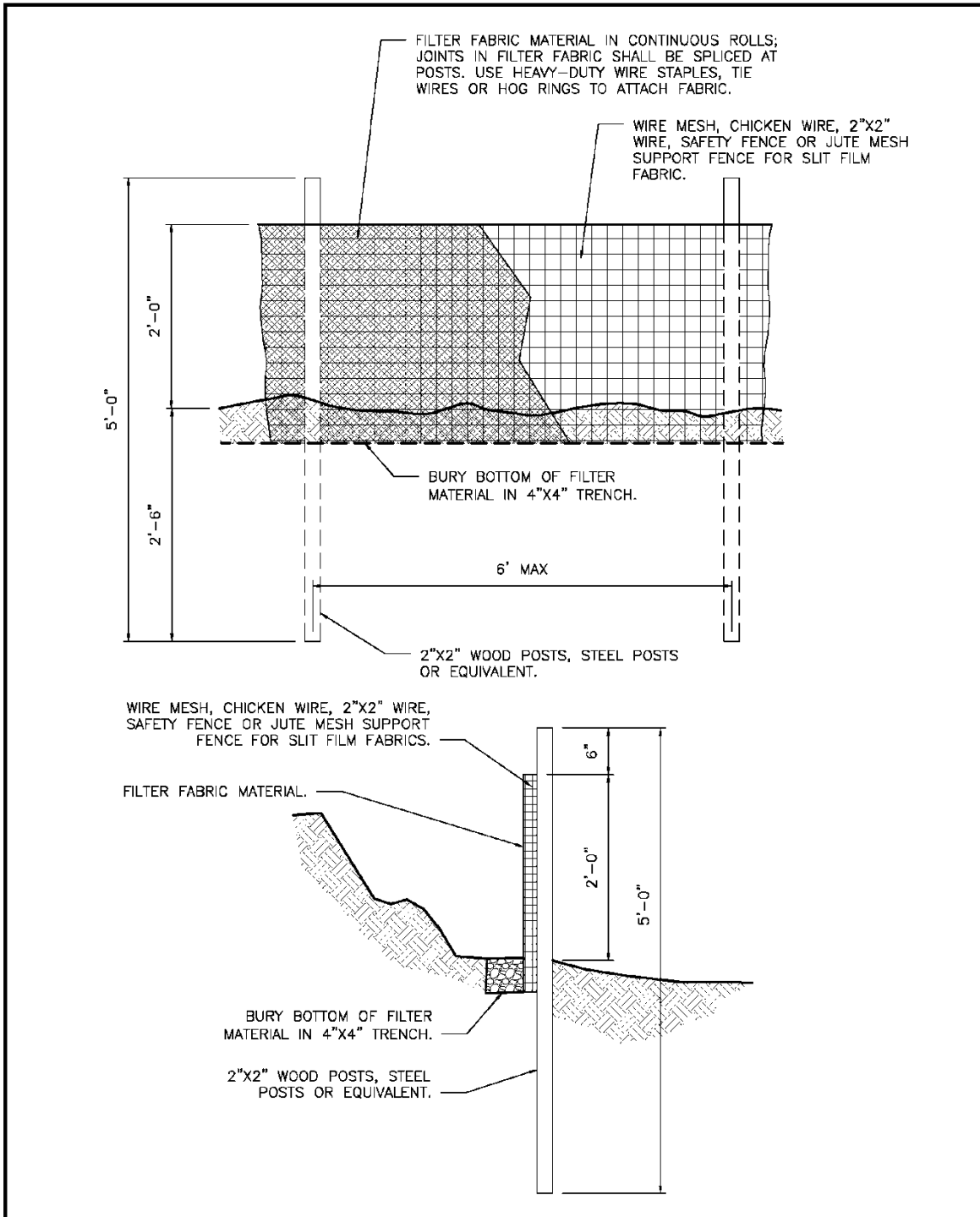

Figure 14. Filter Fence Details.

4.3.2. BMP E3.20: Gravel Filter Berm

Description

A raised gravel berm or mound constructed in traffic areas.

Purpose

To keep sediment away from traffic areas by filtering runoff through gravel or crushed rock.

Conditions Where Practice Applies

- On private property only. This BMP is not allowed in the public right-of-way.
- Where a temporary measure is needed to retain sediment from traffic areas within the project site.

Design Criteria

- Berm material must be 3/4 to 3 inches, washed, well-graded gravel or crushed rock with less than 5 percent fines.
- Spacing of berms, perpendicular to the flow of traffic:
 - Every 300 feet on slopes less than 5 percent.
 - Every 200 feet on slopes between 5 and 10 percent.
 - Every 100 feet on slopes greater than 10 percent.
- Berm dimensions:
 - 1-foot high with 18 percent side slopes.
 - 8 linear feet per 1 cfs runoff based on the 10--year, 24--hour design storm.

Maintenance

- Inspect regularly. Remove sediment and replace filter material when it becomes clogged.

4.3.3. *BMP E3.25: Inlet Protection*

Description

A sediment filter or an excavated impounding area around a storm drain or catch basin.

Purpose

To prevent sediment from entering storm drainage systems prior to permanent stabilization of the disturbed area.

Conditions Where Practice Applies

Where downslope inlets are operational prior to permanent stabilization of the disturbed drainage area. Within the project site, protection should be provided for all inlets downslope and within 500 feet to a block of a disturbed or construction area, whichever is further, unless the runoff that enters the catch basin will be conveyed to a sediment pond or trap.

Drainage areas should be limited to 1 acre or less per inlet. Emergency overflows may be required where stormwater ponding would cause a hazard. If an emergency overflow is provided, additional end-of-pipe treatment may be required. Different types of structures are applicable to different conditions:

- Structures less than 12 inches deep – use other methods to protect the inlet (BMP E3.70 Street Sweeping and Vacuuming).
- Storm drain or catch basin filter sock – applicable on private properties or within the public right-of-way for structures greater than 12 inches deep.
- Block and gravel curb inlet protection – applicable for private properties only, on a paved surface. Sturdy, but limited filtration. Consists of a barrier formed around an inlet with concrete blocks and gravel (Figure 15).
- Curb and gutter barrier – applicable for private properties only, using a sandbag or rock berm (riprap and aggregate) 3 feet high and 3 feet wide in a horseshoe shape (Figure 16). An 8- or 12-inch diameter compost sock may also be used in temporary, low-velocity applications.

Planning Considerations

- The best way to prevent sediment from entering the storm drain is to stabilize the site as quickly as possible, preventing erosion and stopping sediment at its source. Proper implementation of other BMPs, such as filter fence (BMP E3.10), straw wattles (BMP E3.35), and covering practices, can eliminate or reduce the need for downstream inlet protection, and their implementation is mandatory. Clean out the stormwater drain or catch basin prior to implementing this BMP (refer to BMP E3.65 Cleaning Inlets and Catch Basins).
- Within the project site, remove BMP within 5 business days after final site stabilization is achieved or after it is no longer needed, whichever is longer. Daily removal is required when the BMP is necessary and approved to be installed in the street inlets and catch basins for short durations to protect the public drainage system or public combined sewer from pollution-generating activities, such as sawcutting, utility excavation, or paving.

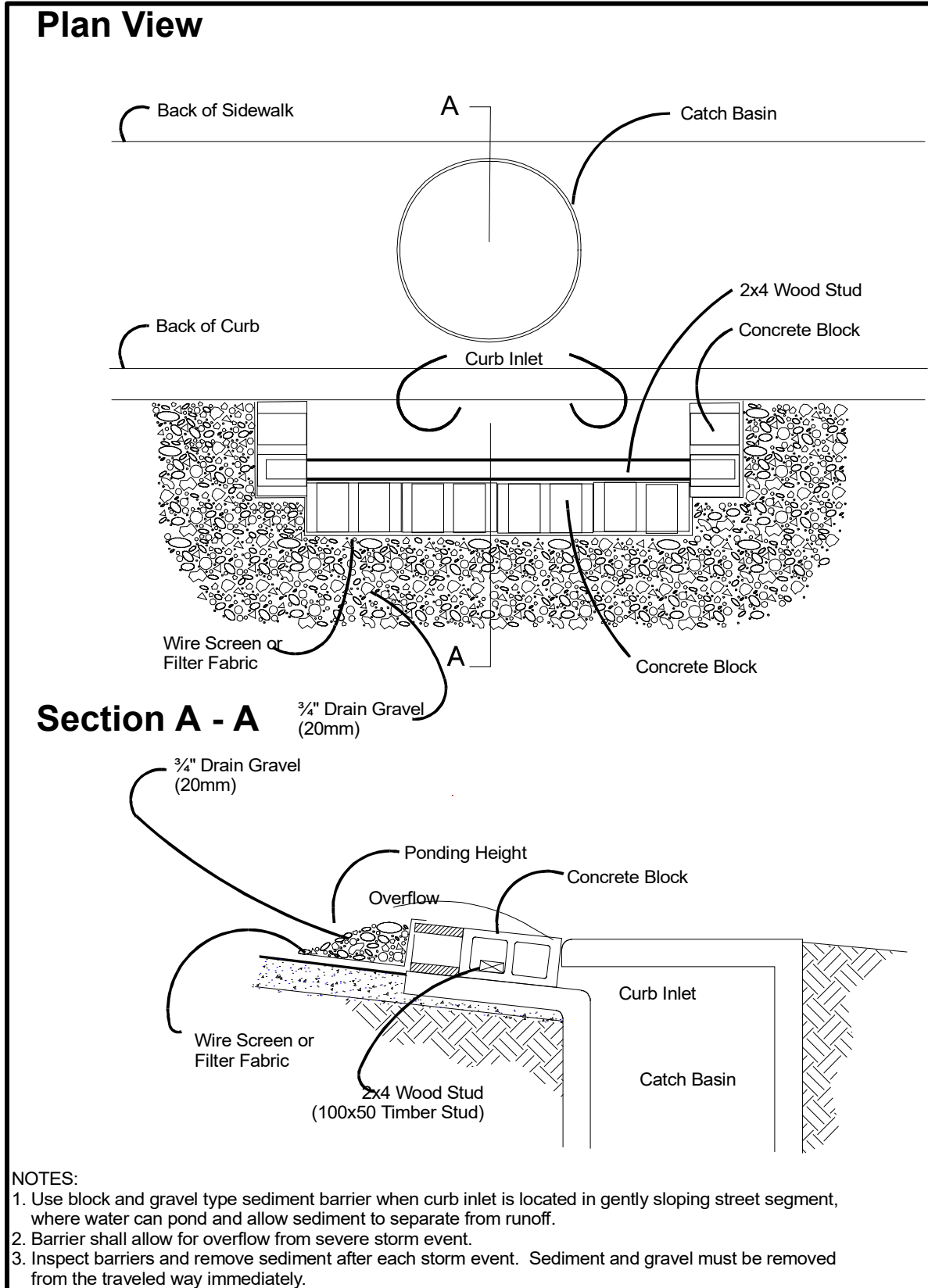

Figure 15. Block and Gravel Curb Inlet Protection.



Figure 16. Curb and Gutter Barrier.

- All methods for inlet protection are prone to plugging and require a high frequency of maintenance.
- Storm drains made operational before their drainage area is stabilized can convey large amounts of sediment to natural drainage channels. In cases of extreme sediment loading, the storm drain itself may clog and lose a major portion of its capacity. To avoid these problems, it is necessary to prevent sediment from entering the system at the inlets.
- Several types of inlet filters and traps have different applications that depend on site conditions and type of inlet. Other innovative techniques for accomplishing the same purpose are encouraged, but only after specific plans and details are submitted to and approved by the SDCI. Note that these various inlet protection devices are for drainage areas of less than 1 acre. Runoff from larger disturbed areas should be routed through a temporary sediment pond or trap (refer to Ecology BMPs C241 and E3.40).

Design Criteria

- Secure grates and spaces of all inlets to prevent seepage of sediment-laden water.
- All catch basin protection measures should include sediment sumps of 1 to 2 feet in depth with 25 percent side slopes.
- Installation procedure for a drain or catch basin filter sock:
 - For structures greater than 12 inches deep, the filter sock can be laid into the inlet as long as the overflow opening is in the direction of the outlet pipe.
 - Trim and remove filter sock material that extends beyond the grate.
 - Make provisions to decant accumulated sediment.
 - Install a high-flow bypass that will not clog under normal use at a project site.
- Installation procedures for block and gravel curb inlet protection:
 - Place two concrete blocks on their sides abutting the curb at either side of the inlet opening—these are spacer blocks.
 - Place a piece of lumber through the outer holes of each spacer block to align the front blocks.
 - Place blocks on their sides across the front of the inlet and abutting the spacer blocks.
 - Place wire mesh with 1/2--inch openings over the outside vertical face.
 - Pile coarse aggregate against the wire to the top of the barrier.
- Installation procedures for curb and gutter sediment barrier:
 - Construct a horseshoe shaped berm.
 - If using riprap, create a face with coarse aggregate 3 feet high and 3 feet wide and at least 2 feet from the inlet.
- Ecology has also approved technologies that are functionally equivalent to storm drain inlet protection. Refer to the Functionally Equivalent Technologies section of Ecology's TAPE website for approved BMPs: <https://ecology.wa.gov/regulations-permits/guidance-technical-assistance/stormwater-permittee-guidance-resources/emerging-stormwater-treatment-technologies>.

Maintenance

- Inspections should be made on a regular basis, especially after large storm events. Inlet protection devices should be cleaned or removed and replaced when sediment has filled one-third of the available storage (unless a different standard is specified by the product manufacturer).
- Do not wash sediment into storm drains while cleaning. Spread all excavated material evenly over the surrounding land area or stockpile and stabilize as appropriate.

4.3.4. *BMP E3.30: Vegetated Strip*

Description

A vegetated area located downslope of a disturbed area that is capable of filtering coarse sediment from runoff and slowing runoff velocities.

Purpose

Vegetated strips reduce the transport of coarse sediment from a project site by providing a temporary physical barrier to sediment and reducing the runoff velocities of overland flow.

Conditions Where Practice Applies

- Vegetated strips may be used downslope of all disturbed areas and placed parallel to the toe of the slope.
- Vegetated strips are not intended to treat concentrated flows, nor are they intended to treat substantial amounts of overland flow. Any concentrated flows must be conveyed through the drainage system to a sediment pond. The only circumstance where overland flow can be treated solely by a strip, rather than by a sediment pond, is when the strip flow path length can be achieved with the associated average slope (Table 8).

Table 8. Vegetated Strip Implementation Criteria.

Average Slope	Slope Percent	Flowpath Length
1.5H:1V or less	67% or less	100 feet
2H:1V or less	50% or less	115 feet
4H:1V or less	25% or less	150 feet
6H:1V or less	16.7% or less	200 feet
10H:1V or less	10% or less	250 feet

Design Criteria

- The vegetated strip must consist of a minimum of a 25-foot-wide continuous strip of dense vegetation with permeable topsoil. Grass-covered landscaped areas are generally not adequate because the volume of sediment overwhelms the grass. Ideally, vegetated strips should consist of undisturbed native growth with a well-developed soil that allows for infiltration of runoff.
- The slope within the strip must not exceed 25 percent.
- Delineate the uphill boundary of the vegetated strip with clearing limits.

Maintenance

- Immediately seed and mulch any areas damaged by erosion or construction activity.
- Install sod if more than 5 feet of the original vegetated strip width has had vegetation removed or is being eroded.
- If there are indications that concentrated flows are traveling across the buffer, install stormwater controls to reduce the flows entering the buffer or install additional perimeter protection.

4.3.5. *BMP E3.35: Straw Wattles, Compost Socks, and Compost Berms*

Description

Temporary erosion and sediment control barriers consisting of encased straw, encased compost, or a compost berm.

Straw wattles consist of straw that is wrapped in biodegradable tubular plastic or similar encasing material. Straw wattles are typically 8 to 10 inches in diameter and 25 to 30 feet in length. The wattles are placed in shallow trenches and staked along the contour of disturbed or newly constructed slopes (Figure 17). Compost socks consist of a net tube, similar to straw wattles, filled with compost, and available in biodegradable mesh or non-biodegradable mesh for installations longer than 6 months. Compost berms are rows of compost with a triangular cross section that can serve a similar function as wattles or socks. Compost socks and berms typically do not require trenching.



Figure 17. Straw Wattles or Compost Sock for Inlet Protection.

Purpose

To reduce the velocity, spread the flow of rill and sheet runoff, and capture and retain sediment.

Conditions Where Practice Applies

- Disturbed areas that require immediate erosion protection.
- Exposed soils during short construction delays or over winter months.
- On slopes requiring stabilization until permanent vegetation can be established.
- For inlet protection or elsewhere on top of pavement to filter or direct flow.
- As an alternative to filter fence for perimeter control.

Planning Considerations

- Compost socks and straw wattles are effective for 1 to 2 seasons. Berms are effective for 1 to 2 weeks, or longer if vegetated, protected by fencing, or both.
- If conditions are appropriate, straw wattles and compost socks can be staked to the ground using willow cuttings for added re-vegetation. Compost socks can also be filled with a compost and seed mix to provide temporary or permanent vegetation. Use biodegradable socks for permanent installations.

Design Criteria

- It is critical that straw wattles and compost socks are installed perpendicular to the flow direction and parallel to the slope contour (Figure 18). Rilling can occur beneath straw wattles if not properly entrenched and water can pass between straw wattles and compost socks if not tightly abutted together.
- In most conditions, compost socks do not require trenching because of their superior ground contact. Straw wattles do require trenching.
- For straw wattles, dig narrow trenches across the slope on contour to a depth of 3 to 5 inches on clay soils and soils with gradual slopes. Construct trenches at contour intervals of 3 to 30 feet apart depending on the steepness of the slope, soil type, and rainfall. The steeper the slope the closer together the trenches.
- Start building trenches and installing wattles from the base of the slope and work up. Spread excavated material evenly along the uphill slope and compact using hand tamping or other methods.
- Install straw wattles snugly into the trenches and abut tightly end to end. Do not overlap the ends. Install stakes at each end of the wattle and at 4-foot centers along entire length of wattle. If required, install pilot holes for the stakes using a straight bar to drive holes through the wattle and into the soil.
- On loose soils, steep slopes, and areas with high rainfall, dig the trenches to a depth of 5 to 7 inches or one-half to two-thirds of the thickness of the wattle.
- At a minimum, use wooden stakes that are approximately $\frac{3}{4}$ inches square and 24 inches long. Willow cuttings or $\frac{3}{8}$ -inch rebar can also be used for stakes. Drive stakes through the middle of the straw wattle or compost sock, leaving 2 to 3 inches of the stake protruding above the wattle or sock.
- Compost socks are usually placed on the prepared surface, without trenching, so long as no rilling exists on that surface. If the surface is sloped, stake through the sock at 10-foot intervals or more closely on steeper slopes. After staking, walk down the top of the sock to press it onto the ground surface.

- Compost berms are typically 1 foot high by 2 feet wide at the base, or 18 inches high and 3 feet wide.
- Protect compost berms from foot or vehicle traffic by a fence or otherwise immediately seed to provide stability. Short-term (1 to 2 week) applications may not require protection and stabilization.

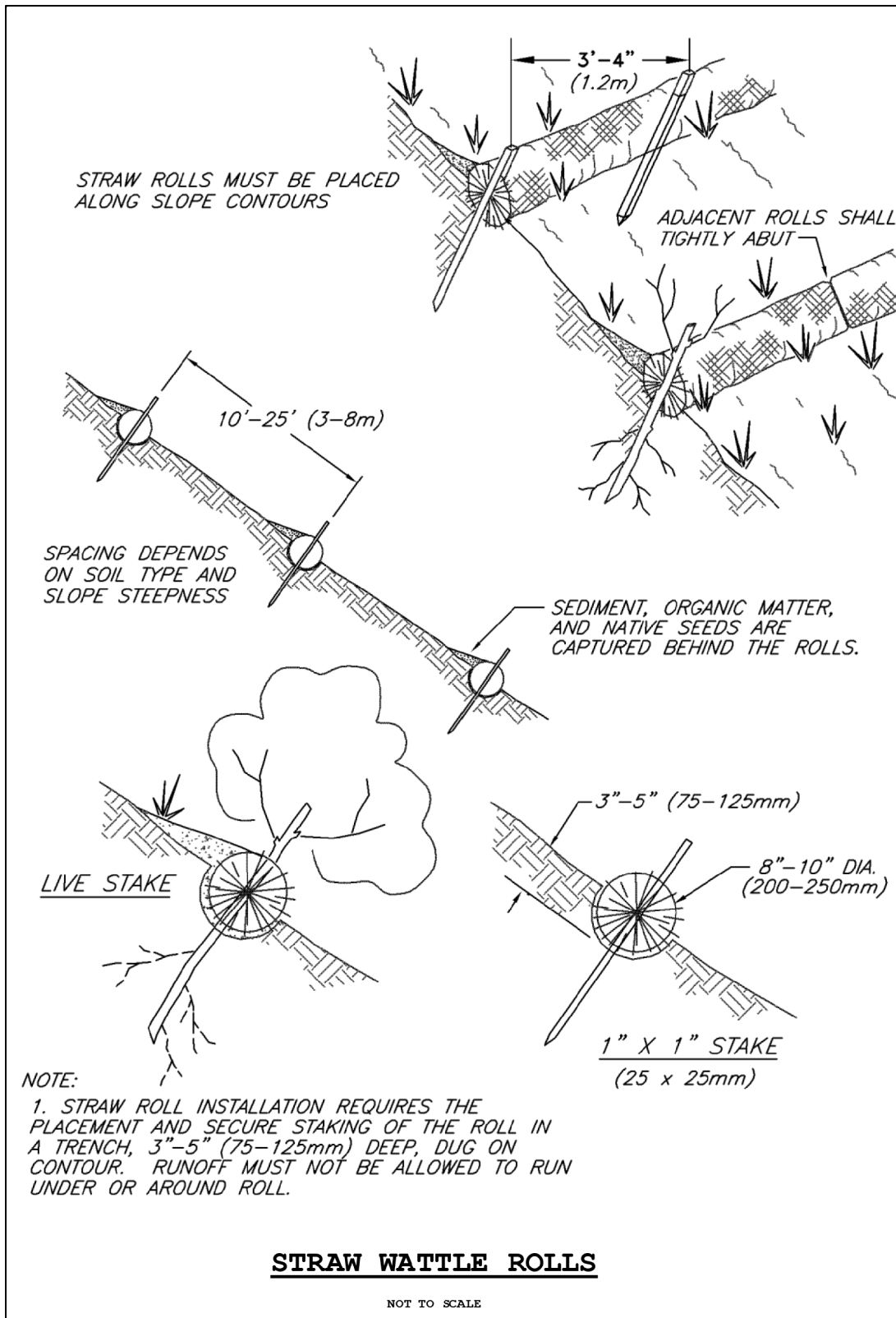

Figure 18. Straw Wattle Details.

Ecology has also approved technologies that are functionally equivalent to wattles. Refer to the Functionally Equivalent Technologies section of Ecology's TAPE website for approved BMPs: <https://ecology.wa.gov/regulations-permits/guidance-technical-assistance/stormwater-permittee-guidance-resources/emerging-stormwater-treatment-technologies>.

Maintenance

- Inspect wattles to ensure they are in contact with soil and thoroughly entrenched, especially after significant rainfall on steep sandy soils. Repair as necessary.
- Straw wattles and compost socks can be compressed by vehicle traffic, creating an overflow point. Repair immediately.
- Inspect the slope after significant storms and repair any areas where wattles are not tightly abutted or water has scoured beneath the wattles.

4.3.6. BMP E3.40: Sediment Trap

Sizing is less important than constant maintenance for this BMP because it is a temporary control. Inspections must be made and sediment removed regularly for sediment traps to function well.

Description

A small temporary ponding area with a gravel outlet formed by excavation or by constructing an earthen embankment.

Purpose

To collect and store sediment from project sites cleared, graded, or both during construction. It is intended for use in relatively small drainage basins with no unusual drainage features, and a projected quick build-out time. It should help in reducing silt-laden runoff that clogs offsite conveyance systems and destroys habitat, particularly in streams.

Conditions Where Practice Applies

Proposed building sites where the tributary drainage basin is less than 3 acres.

Planning Considerations

- Prior to leaving a project site where the tributary drainage is 3 acres or less, stormwater runoff must pass through a sediment pond or other appropriate sediment removal BMP (refer to Attachment 1, Table 1a and Table 1b for other approved stormwater controls).
- If the contributing drainage area is greater than 3 acres, refer to Ecology BMP C241 Sediment Pond (Temporary) or subdivide the tributary drainage area.
- The trap is a temporary measure (with a design life of approximately 6 months) and is to be maintained until the project site is permanently protected against erosion by vegetation, structures, or both.
- Sediment must be periodically removed from the trap. Plans should detail how this sediment is to be disposed of, such as by use in fill areas on site or removed to an approved offsite dump. Sediment traps, along with other perimeter controls, must be installed before any land disturbance takes place in the drainage area.
- Alternative Methods: Consider using a temporary aboveground storage tank (e.g., Baker Tank) for temporary storage. If a tank cannot be used, consider using a pond with pumping capabilities to another temporary holding structure. Refer to BMP E3.50 Portable Sediment Tank.
- Wherever possible, sediment-laden water should be discharged into onsite, relatively level, vegetated areas (refer to BMP E3.30 Vegetated Strip).
- Projects that are constructing permanent flow-control BMPs or runoff treatment BMPs that use ponding for treatment may use the rough-graded or final-graded permanent BMP footprint for the temporary sediment trap. Refer to *Volume 3 – Project Stormwater Control* for additional requirements.

Safety

Sediment traps and ponds should be limited to project sites where failure of the structure would not result in loss of life, damage to homes or buildings, or interruption of use or service of public roads or utilities.

Sediment traps and ponds are attractive to children and can be very dangerous. Local ordinances regarding health and safety must be adhered to. If fencing of the pond is required, the type of fence and its location must be shown in the Construction Stormwater Pollution Control Plan.

Design Criteria

To determine the sediment trap geometry, first calculate the design surface area (SA) of the trap, measured at the invert of the weir (Figure 19). Use the following equation:

$$SA = FS(Q/V_s)$$

Where:

Q = Peakflow rate

The peak flow rate must be calculated by one of the following methods:

- **Single Event Hydrograph Method:** The peak flow rate from a 2--year, 24--hour design storm with a 10--minute time step. The 10--year peak flow rate must be used if the project size, expected timing and duration of construction, or downstream conditions warrant a higher level of protection, including but not limited to the following situations:
 - The site is within 1/4 mile of an open creek or a wetland.
 - There will be more than 1 acre of clearing and grading or land disturbance that is likely to occur during the wet season.
 - There is a known erosion or sediment problem downstream of the site.
 - When the downstream system is considered capacity constrained.
- **Continuous Simulation Method:** The 50 percent annual probability or 10 percent annual probability flows (2-year or 10---year recurrence interval, respectively) as outlined above with a 15--minute time step or less.
- **Rational Method:** If no hydrologic analysis is required for the other portions of the site design (conveyance, flow control, water quality control, or some or all of these) and the site is less than 1 acre, the Rational Method may be used for sediment trap design. Refer to *Appendix F* for additional guidelines.

When calculating the peak flow rate, the land use cover used in the calculations must represent the conditions during construction that result in the most runoff (e.g., 100 percent impervious for sites that will not have any vegetated areas that are protected during construction) unless multiple sizes are given for different stages of the construction.

V_s = the settling velocity of the soil particle of interest. The 0.02-millimeter (mm) (medium silt) particle with an assumed density of 2.65 grams per cubic centimeter (g/cm^3) has been selected as the particle of interest and has a settling velocity (V_s) of 0.00096 ft/sec.

FS = A safety factor of 2 to account for non-ideal settling.

Therefore, the equation for computing sediment trap surface area becomes:

$$SA = \frac{2 \times Q}{0.00096} \text{ or } 2,080 \text{ square feet per cfs of inflow}$$

Note: Even if permanent facilities are used, they must still have a surface area that is at least as large as that derived from the above formula. If they do not, the pond must be enlarged.

The outlet riser or pipe should be 3.5 feet minimum above bottom to draw clean water and avoid discharging sediment that is still suspended in the lower part of the water column.

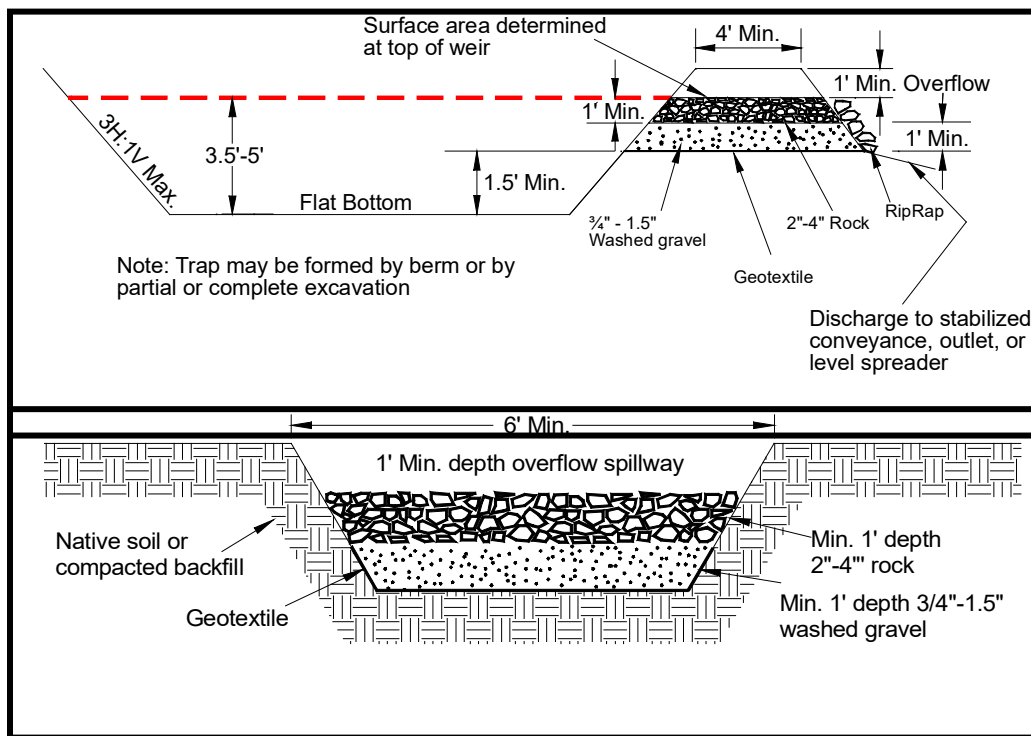

Figure 19. Cross Section of Sediment Trap and Outlet.

To aid in determining sediment depth, all sediment traps should have a staff gauge with a prominent mark 1 foot above the bottom of the trap.

Maintenance

- The sediment trap must be continually monitored and regularly maintained. The size of the trap is less important to its effectiveness than is regular sediment removal. Remove sediment from the trap when it reaches approximately 1 foot in depth

(assuming a 1.5 foot sediment accumulation depth). Conduct regular inspections and additional inspections after each large runoff-producing storm.

- Maintain and repair all temporary and permanent erosion and sediment control practices as needed to ensure continued performance of their intended function.
- Remove all temporary erosion and sediment control measures within 5 business days after final site stabilization is achieved, or after the temporary BMPs are no longer needed, whichever is longer. Remove trapped sediment or stabilize on site. Permanently stabilize disturbed soil areas resulting from removal.

4.3.7. BMP E3.50: Portable Sediment Tank

Description

A compartmental tank brought temporarily to a project site. Sediment-laden water is pumped into the tank to trap and retain sediment.

Purpose

A portable sediment tank is used for temporary storage of sediment-laden water and to trap and retain sediment prior to discharging to an appropriate discharge point.

Conditions Where Practice Applies

A portable sediment tank should be used on sites where excavations are deep and space is limited, or wherever the tank can be located per the manufacturer's specifications with an appropriate discharge point.

Planning Considerations

Using a portable sediment tank is the preferred method to minimize potential impacts to the project site. The tank configuration, size, location, and discharge point must be presented in the Construction Stormwater Control and Soil Management Plan and approved by the City.

Follow the manufacturer's or vendor's specifications for choosing the appropriate location. In addition, the tank should be located for ease of clean-out and disposal of trapped sediment, and to minimize the interference with construction activities and pedestrian traffic.

If a permit is obtained for discharge to a combined sewer system, conduct all discharge activities in accordance with permit requirements, including when it can be discharged and the discharge flow rate.

Design Criteria

Sediment tanks must have a minimum depth of 2 feet and be designed to allow for emergency flow to an approved discharge point. Outlet riser or pipe should be 1.5 feet minimum above bottom to draw clean water and avoid discharging sediment that is still suspended in the lower part of the water column.

As noted above, tank configuration and size must be presented in the Construction Stormwater Control and Soil Management Plan and approved by the City. For planning purposes, use the following formula to determine the minimum storage volume of the sediment tank. This formula is equivalent to 120 minutes of residence time. Additional storage volume may be required by the City.

Peak flow rate in gallons per minute (gpm) x 16 = cubic feet storage,

or

Peak flow rate in gallons per minute (gpm) x 120 minutes = gallons of storage.

Refer to *Section 4.3.6* for BMP E3.40 Sediment Traps for design peak flow rate selection requirements.

In some cases, it may be necessary to hold drainage on site and truck it off site to discharge in a different location. Examples include when no off-site point of discharge is available for drainage or the construction stormwater runoff or groundwater needing discharge is contaminated. In this case, the following is required:

- The sediment tanks must be sized to store the full volume from a 2-year, 24-hour storm event. These tanks must always be available on the site. Additional volume may be required during the rainy season (November through April).
- The discharge water and sediment must be taken to a discharge facility that is permitted and authorized to accept the type of discharges present in the sediment tanks. For example, if there are contaminants in the discharge, the facility must be permitted and authorized to accept the volume of discharge and the type of any contaminants present. Discharge tickets provided by the facility must be presented to the City inspector for approval.
- Special Inspections by a third party may be required, as determined by the Director.

Container designs can vary from cylindrical tanks to rectangular boxes, depending on the manufacturer. Any tank configuration can be used if the storage volume is adequate and approval is obtained from the City.

Effectiveness

The pollution removal efficiency of the sediment tank can be increased by using flocculation chemicals, such as alum (aluminum sulfate) in the tank. Flocculation will allow very small, suspended particles to settle out and decrease the time it takes for larger particles to settle out. Flocculation tank setup is considerably more complicated because the rate of flocculent addition must be carefully monitored.

For sites that do not require coverage under Ecology's Construction Stormwater General Permit, formal written approval from the City is required to use chemical treatment such as flocculation chemicals, regardless of site size. Any proposed chemicals and the method of use must also be formally approved by Ecology. Refer to Ecology BMP C250 for more information on chemical treatment.

Alternatives

An alternative to a portable sediment tank is a tank constructed using steel drums, sturdy wood, or other material suitable for handling the pressure exerted by the volume of the water.

- Sediment tanks must have a minimum depth of 2 feet.
- The tank must be located for easy clean-out and disposal of the trapped sediment and to minimize the interference with construction activities.
- Once the water level nears the top of the tank, the pump must be shut off while the tank drains and additional capacity is made available.
- Clean out the tank as soon as one-third of the original capacity is depleted due to sediment accumulation. The tank must be clearly marked showing the cleanout point.
- An appropriate discharge point must be selected and approved by the City.

Maintenance

- Follow the manufacturer's or vendor's specifications.
- During construction, inspect BMPs daily during the work week with additional inspections scheduled during storm events. Make any required repairs immediately.
- Inspect filtering or control devices frequently. Repair or replace them to ensure that the structure functions as designed.
- Clean out the tank as soon as one-third of the original capacity is depleted due to sediment accumulation. The tank must be clearly marked showing the clean-out point. Removed sediment may be disposed of on site if no contamination is present. Contaminated sediment must be disposed of according to local governing agency requirements.
- Systems should be filled in or otherwise removed when permanent dewatering controls are in place and connected to an approved treatment and receiving system.

4.3.8. *BMP E3.60: Construction Stormwater Filtration*

Description

Use of a filter to remove sediment from stormwater runoff.

Purpose

Filtration removes sediment from runoff originating from disturbed areas of the site.

Conditions Where Practice Applies

Construction stormwater filtration should be used when traditional construction stormwater BMPs used to control soil erosion and sediment loss from construction sites may not be adequate to ensure compliance with the water quality standard for turbidity in the receiving water. Filtration may be used in conjunction with gravity settling to remove sediment as small as fine silt (0.5 micrometers [μm]). The reduction in turbidity will be dependent on the particle size distribution of the sediment in the stormwater. In some circumstances, sedimentation and filtration may achieve compliance with the water quality standard for turbidity.

Unlike chemical treatment, the use of construction stormwater filtration does not require approval from Ecology. Filtration may also be used in conjunction with polymer treatment in a portable system to ensure capture of the flocculated solids. Filtration in conjunction with polymer treatment requires testing under the Chemical Technology Assessment Protocol – Ecology (CTAPE) before it can be initiated. Approval from Ecology must be obtained at each site where chemical use is proposed prior to use. For more guidance on stormwater chemical treatment, refer to Ecology BMP C250.

Filtration with sand media has been used for over a century to treat water and wastewater. The use of sand filtration for treatment of stormwater has developed recently, generally to treat runoff from streets, parking lots, and residential areas. The application of filtration to construction stormwater treatment is currently under development.

Design Criteria

Two types of filtration systems may be applied to construction stormwater treatment: rapid and slow.

- Rapid filtration systems are the typical system used for water and wastewater treatment. These systems can achieve relatively high hydraulic flow rates, on the order of 2 to 20 gallons per minute per square foot (gpm/sf), because they have automatic backwash systems to remove accumulated solids.
- Slow filtration systems have very low hydraulic rates, on the order of 0.02 gpm/sf, because they do not have backwash systems. Slow filtration systems have generally been used as postconstruction BMPs to treat stormwater. Slow filtration is mechanically simple compared to rapid filtration but requires a much larger filter area.

Filter Type and Efficiencies

Sand media filters are available with automatic backwashing features that can filter to 50 µm particle size. Screen or bag filters can filter down to 5 µm. Fiber wound filters can remove particles down to 0.5 µm. Filters should be sequenced from the largest to the smallest pore opening. Sediment removal efficiency will be related to particle size distribution in the stormwater.

Treatment Process and Description

Stormwater is collected at interception point(s) on the site and is diverted to an untreated stormwater sediment pond or tank for removal of large sediment and storage of the stormwater before it is treated by the filtration system. In a rapid filtration system, the untreated stormwater is pumped from the pond or tank through the filtration media. Slow filtration systems are designed using gravity to convey water from the pond or tank through the filtration media. If large volumes of concrete are being poured, pH adjustment may be necessary (refer to BMPs C1.56, C1.58, and C1.59).

Sizing for Flow-through Treatment Systems for Discharges to Designated Receiving Waters:

Filtration treatment systems must be designed to control the velocity and peak flow rate that is discharged from the system and consequently the project site. Refer to *Element 4 Protect Downstream Properties and Receiving Waters* (SMC 22.805.020.D) for further detail on this requirement.

The untreated stormwater storage pond or tank must be sized to hold 1.5 times the runoff volume of the 10--year, 24--hour storm event minus the treatment system flow rate for an 8-hour period.

$V_s = (1.5 \times V_{10}) - (Q_t \times 60 \text{ minutes/hour} \times 8 \text{ hours})$ where:

V_s = volume of storage pond or tank (gallons)

V_{10} = runoff volume of the 10-year, 24-hour storm in (gallons)

Q_t =filtration treatment system flow rate (gpm)

If groundwater dewatering will be conducted and will be treated with filtration, the capacity of the filtration treatment system must be sized to account for the groundwater dewatering rate plus the peak flow rate from the 2-year, 24-hour storm at a minimum. In addition, the storage pond or tank size must be confirmed to provide at least 2 hours (120 minutes) of residence time for the combined groundwater dewatering rate and the 2-year, 24-hour storm.

$$Q_t = Q_{gw} + Q_2$$

and

Check that $V_s \geq (Q_{gw} + Q_2) \times 120 \text{ minutes}$

where:

V_s = volume of storage pond or tank (gallons)

Q_{gw} = groundwater dewatering rate (gpm)

Q_2 = peak runoff flowrate from 2-year, 24-hour storm (gpm)

For a chitosan-enhanced sand filtration system, the treatment system flow rate must be sized using a hydraulic loading rate between 6 and 8 gpm/sf. Other hydraulic loading rates may be more appropriate for other systems.

Bypass must be provided around the filtration treatment system to accommodate extreme storms. Runoff volume must be calculated using the methods presented in *Volume 3, Chapter 4*. Worst-case land cover conditions (i.e., producing the most runoff) must be used for analyses (in most cases, this would be the land cover conditions just prior to final landscaping).

Sizing for Listed Creek Basins and Non-listed Creek Basins:

Sites that must implement flow control for developed site conditions must also control stormwater release rates during construction. See Section 4.4.1 BMP E4.10 Temporary Flow Control During Construction.

Maintenance

- Rapid sand filters typically have automatic backwash systems triggered by a pre-set pressure drop across the filter. If the backwash water volume is not large or substantially more turbid than the stormwater stored in the holding pond or tank, return of backwash to the pond or tank may be appropriate. However, land application or another means of treatment and disposal may be necessary.
- Screen, bag, and fiber filters must be cleaned or replaced when they become clogged.
- Sediment should be removed from the storage and treatment ponds as necessary. Typically, sediment removal is required once or twice during a wet season and at the decommissioning of the ponds.

4.3.9. BMP E3.65: Cleaning Inlets and Catch Basins

Description

Removal of debris from existing inlets, catch basins, and connecting pipelines to protect and maintain private facilities and the public drainage system.

Purpose

The purpose of cleaning inlets and catch basins is to restore the function of the drainage collection system and reduce sediment transfer through the public drainage system or public combined sewer system.

Conditions Where Practice Applies

- Whenever other sediment control BMPs are not feasible or have failed.
- Whenever the public drainage collection facilities immediately downstream are not functioning.
- Whenever there is ponding in the travel lanes of the public roadway.

Planning Considerations

Large amounts of sediment can be conveyed through inlets, catch basins, and the public drainage system or public combined sewer. Sediment can also plug these facilities, causing a flooding hazard or a hazard to traffic and pedestrians in the public roadway. Protection from sediment and debris is not always possible or effective; therefore, cleaning is the last action taken.

The best ways to prevent sediment from entering the storm drain are:

- Control the discharge points.
- Stabilize the site to control pollution at its source.
- Good housekeeping such as sweeping, vacuuming, and cleaning (BMP E3.70).
- Identify which BMP is feasible at each point of drainage collection and discharge and during each construction phase. Inlet and catch basin cleaning must be performed when other protection methods are not possible or fail.

Design Criteria

- Identify the drainage flow path(s) on site and downstream for a minimum distance of 500 feet or one block, whichever is further, in the public roadway.
- Identify the location of all existing inlets and catch basins within the project area that may be impacted. Identify whether they will remain, be removed, or abandoned during construction.
- When an inlet or catch basin is to be removed or abandoned, plug that path to the public drainage system or public combined sewer prior to demolition of the immediate surroundings.
- Inlet protection (BMP E3.25) is required when feasible. When it is not feasible or fails, clean affected inlets, catch basins, and connecting pipe.

- Use a vacuum truck or shovels with proper disposal for cleaning. Jetting material downstream into the public drainage system or public combined sewer is not allowed.
- Protect new inlets and catch basins from onsite sediment and clean after site stabilization as necessary.

Maintenance

- Regularly inspect inlets and catch basins on site and within a distance of 500 feet or one block, whichever is further, in the public roadway. Increase inspections as necessary, especially after street sweeping.
- Clean inlets when sediment, debris, or both are visible.
- Clean catch basins whenever debris, sediment, or both occupy more than one-half the capacity or are within 18 inches of the outlet pipe invert.
- Always clean inlets and catch basins after site stabilization.

4.3.10. BMP E3.70: Street Sweeping and Vacuuming

Description

Use of human-powered or mechanical equipment to collect sediment on paved surfaces to minimize sediment accumulation in private systems and the public drainage system. This BMP may also be used to clean paved surfaces in preparation for final paving.

Purpose

Sweeping and vacuuming minimizes project area sediment from entering the public drainage system or public combined sewer. Targeted pollutants include sediment, nutrients, trash, metals, bacteria, oil and grease, and organics.

Conditions Where Practice Applies

Sweeping and vacuuming are suitable on any paved surface and, in particular, anywhere sediment is tracked from the project site onto public or private paved streets and roads, typically at the stabilized construction access (BMP E2.10) and other construction access points. Sweeping and vacuuming are also applicable during preparation of paved surfaces for final paving.

Planning Considerations

Sweeping and vacuuming may not be effective when sediment is wet or when tracked soil is caked (caked soil may need to be scraped loose). Washing is not an alternative to sweeping and vacuuming because of the risk of pollutant transport.

Design Criteria

- Control the number of points where vehicles can leave the site to allow focused sweeping and vacuuming efforts.
- Do not use kick brooms or sweeper attachments.
- Consider incorporating the removed sediment back into the project if not mixed with debris or trash.

Maintenance

- After initiating sweeping, vacuuming, or both, inspect the potential sediment tracking locations daily to ensure they are clean of any sediment.
- Visible sediment tracking must be swept or vacuumed on a daily basis.
- Be careful not to sweep up any unknown substance or any object that may be potentially hazardous.
- Adjust brooms frequently; maximize efficiency of sweeping operations.
- After sweeping is finished, properly dispose of sweeper wastes at an approved disposal site.

4.4. Flow Control & Dewatering Practices

4.4.1. *BMP E4.10: Temporary Flow Control During Construction*

Description

Projects that meet the criteria in Section 4.4.1.3 below must provide flow control BMPs during construction to detain stormwater runoff and dewatering flow before it leaves the construction site. The BMPs used for sediment control (e.g. sediment traps, sediment tanks) may also be used for flow control, but they must be sized using a continuous runoff model to meet the temporary flow control standard. Note: the sizing of BMPs in the Sediment Control section of this Manual do not necessarily meet the flow control standard.

Purpose

The purpose of temporary flow control during construction is to protect properties and waterways downstream of development sites from flooding and erosion due to increases in the velocity, duration, and flow rate of stormwater runoff that occur during construction as a result of clearing vegetation, compacting the soil, and adding impervious surface.

Flow control during construction consists of three main elements:

1. Interception of runoff and dewatering flow.
2. Conveyance of the flow to a flow control BMP as required. This can be a modified sediment BMP that is designed to provide the required flow control.
3. Controlled release of the runoff downstream of any disturbed areas at the approved point of discharge.

Conditions Where Practice Applies

Large projects that include more than 10,000 square feet of new plus replaced hard surface area AND that meet any of the following criteria must implement flow control during construction:

- The site discharge is within 1/4 mile of an open creek or a wetland.
- There is a known flooding, erosion, or sediment problem downstream of the site.
- The site discharges to a capacity constrained system or its basin.

If the criteria above apply, construction site stormwater plus dewatering discharges must not exceed the discharge durations of the existing condition for the range of existing discharge rates from one-half of the 2-year flow through the 10-year flow as predicted by an approved continuous runoff model. In addition, if there will be groundwater dewatering, the peak flowrates from the existing condition for the 2-year and 10-year recurrence intervals must not be exceeded during construction, including both the construction stormwater and groundwater discharges.

The existing condition to be matched must be the landcover condition immediately prior to the development project. This restriction on release rates can affect the size of the sediment trap or sediment tank, the filtration system, and the flow rate through the filter system. It may also require additional BMPs.

For all other scenarios and project sizes, discharges from projects sites will be limited by the SPU allowable discharge rates, unless otherwise approved by the Director. Refer to SPU Design Standards and Guidelines Appendix 18B Temporary Discharges for allowable discharge rates.

Flow control must be installed or otherwise provided prior to any clearing, or grading of the site, except as required to construct the flow control facilities.

Planning Considerations

Flow control measures must be planned and accounted for on the site early on. Flow control BMP configuration, size, location, and discharge point must be presented in the Construction Stormwater Control and Soil Management Plan and approved by the City.

Design Criteria

Construction site stormwater discharges, including dewatering, must not exceed the discharge durations of the pre-developed condition for the range of existing condition discharge rates from one-half of the 2-year flow through the 10-year flow as predicted by an approved continuous runoff model. The existing condition to be matched must be the landcover condition immediately prior to the development project. In addition, if there will be groundwater dewatering, the peak flowrates from existing condition for the 2-year and 10-year recurrence intervals must not be exceeded during construction, including both the construction stormwater and groundwater discharges.

If the developed site requires flow control and the permanent flow control does not include infiltration, the permanent flow control must be constructed first and used during construction to control flow from the site if feasible.

The following is how the Western Washington Hydraulic Model (WWHM) can be used to size flow control, including when a chemical treatment system is used. The same design steps can generally be used for MGSFlood:

1. Determine the pre-project flow durations to be matched by entering the existing land use area under the “Pre-developed” scenario in WWHM. The default flow range is from one-half of the 2-year flow through the 10-year flow.
2. Enter the land cover scenario during construction that will result in the most stormwater runoff for land use area in the “Mitigated” scenario in WWHM. The “Mitigated” land use is typically 100% impervious for projects in Seattle unless there are portions of the site that are vegetated and will be preserved throughout construction.
3. While in the “Mitigated” scenario, add a pond or vault element under the basin element.
 - a. If using multiple tanks for detention, the stage/storage/discharge (SSD) relationship must consider the relative elevation of each tank or the plans must stipulate that all tanks are set at the same elevation.
 - b. Provide 2 feet of dead storage below the lower orifice of the flow control riser.

- c. In cases where the discharge is controlled by a pump, a stage/storage/discharge (SSD) table representing the pond or vault must be generated outside WWHM and imported into WWHM. WWHM can route the runoff from the post-developed condition through this SSD table (the pond or tank) and determine compliance with the flow duration standard. This would be an iterative design procedure where, if the initial SSD table proved to be inadequate, the designer would have to modify the SSD table outside WWHM and re-import into WWHM and route the runoff through it again. The iteration will continue until a pond or vault that complies with the flow duration standard is correctly sized.

Example for SSD table characteristics: A potential scenario is to initially set the pump discharge rate at just below one-half of the 2-year flow from the pre-developed condition. As runoff coming into the stormwater storage pond or tank increases and the available stormwater storage volume gets filled up, it may be necessary to increase the pump discharge rate above one-half of the 2-year flow. The increase(s) above one-half of the 2-year flow must be such that the amount of required storage is reduced but at the same time will not cause violations of the flow duration standard at the higher flows. The final design SSD table will identify the appropriate pumping rates and the corresponding stage and storages.

- d. When building such a flow control system, the design must ensure that any automatic adjustments to pumping rates will be a result of changes to the available storage in accordance with the final design SSD table.
- e. Note that the above procedures would be used to meet the flow control requirements. Filtration or chemical treatment systems must be able to meet the runoff treatment requirements as described in elsewhere in this volume. It is likely that the discharge flow rate of one-half of the 2-year flow or more may exceed the treatment capacity of the system. If that is the case, the untreated stormwater discharge rate(s) (i.e., influent to the treatment system) must be reduced to allow proper treatment. Any reduction in the flows would likely result in the need for a larger untreated stormwater storage volume.

If the discharge is to the storm drainage system, the allowable discharge rate may also be limited by the capacity of the public system. Refer to SPU Design Standards and Guidelines Appendix 18B Temporary Discharges for allowable discharge rates. It may be necessary to clean the municipal system prior to the start of the discharge to prevent scouring solids from the drainage system.

Maintenance

- Flow control measures must be monitored and promptly maintained to fully functioning condition as necessary to ensure continued performance of their intended function.
- Flow control facilities, including control structures, must be inspected at least once every calendar week and within 24 hours of any flow discharged from the site. After any 24-hour runoff-producing event, any control structures will be inspected for integrity.

- At no time will more than 1 foot of sediment be allowed to accumulate in a control structure. Sediment in the control structure must not be allowed to interfere with its operation.
- At no time will more than 6 inches of sediment be allowed to accumulate in a flow control pond, trap, or tank.
- Maintain and repair all temporary and permanent BMPs as needed to ensure continued performance of their intended function in accordance with BMP specifications.

4.4.2. BMP E4.20: Temporary Groundwater Dewatering

Description

The removal and appropriate discharge and release of groundwater, whether from a simple trench or a large excavation.

Purpose

Temporary dewatering is used when groundwater must be removed before certain operations can be performed or to keep work conditions safe. It is typical for contractors to use ditch pumps or well points to dewater, but it is very important to identify and use the appropriate locations for discharge. Dewatering may require a temporary BMP for settling and/or filtering sediment-laden water. A temporary sediment pond or other equivalent facility is used to settle and filter the water. Properly designed and implemented temporary dewatering will:

- prevent the discharged water from eroding soil on site.
- remove sediment from the collected water.
- choose the best location for discharge.
- preserve downstream natural resources and real property.

Projects that are required to comply with Minimum Requirements for Flow Control (SMC 22.805.080) must account for dewatering discharge in determining an allowable release rate.

Conditions Where Practice Applies

Public or private properties with the following:

- Foundation excavations
- Utilities and infrastructure construction projects, including installation, repair, and maintenance of:
 - Electrical conduits
 - Vaults and tanks
 - Sanitary sewer and public drainage systems
 - Phone and cable lines
 - Gas or other fuel lines
 - Other excavations or graded areas requiring dewatering

Clean, non-turbid dewatering water, such as well-point groundwater, may be discharged to the public combined sewer, systems tributary to receiving waters, or directly into receiving waters, provided the dewatering flow is discharged to a stabilized system and does not cause erosion or flooding of receiving waters or downstream systems. Clean dewatering water should not be routed through stormwater sediment ponds.

If dewatering must occur, a Side Sewer Permit for Temporary Dewatering (SSPTD) and a Discharge Authorization Letter from King County Industrial Waste may be required prior to

commencing dewatering at the site. The SSPTD permit may include a separate Temporary Dewatering Plan, water quality treatment, or flow control requirements as well as compliance monitoring requirements.

Planning Considerations

Prior to implementing temporary dewatering, reduce the amount of water that will be collected and the potential amount of sediment that may enter the water. Implement the following prior to temporary dewatering:

- For trench excavation, limit the trench length to 150 feet and place the excavated material on the up-gradient side of the trench.
- Install diversion ditches or berms to reduce the amount of clean stormwater runoff allowed into the excavated area.
- Dewatering in periods of intense, heavy rain when the infiltrative capacity of the soil is exceeded should be avoided.
- Never discharge to bare or newly vegetated areas.

Once the site has been prepared as described above, assess the site for the issues listed below to assist the City in determining which discharge option to approve:

- Water clarity. If the water is turbid (cloudy), dissolved and settleable solids are present in the water that should be filtered or settled out prior to discharge. Determine if contaminants are present in impounded water. Check for odors, discoloration, or oily sheen. Check any soils or groundwater testing results.
 - If contamination may be or is present, the Director of SPU reserves the right to require sampling and analysis to prove that water quality is being protected. Highly turbid or contaminated dewatering water must be handled separately from stormwater. Contaminated groundwater is a prohibited discharge; however, it may be treated to become a permissible discharge if metals and other pollutants are mitigated to meet concentration thresholds in state water quality standards. If no such water quality standards exist for a pollutant, discharge limits must be based on the stricter standard of any other appropriate and relevant water quality criteria (i.e., Washington State water quality standards, U.S. EPA national recommended water quality criteria for aquatic life and human health, and the National Toxics Rule). Depending on the type of downstream infrastructure and the desired discharge volume, the dewatering discharge flow rate may be required to be limited to a daily (measured by gallons or cubic feet per day) or instantaneous (measured by gallons or cubic feet per second) maximum. Refer to additional requirements in Section 4.3.8. BMP E3.60 Construction Stormwater Filtration.

Design Criteria

One of several types of dewatering facilities may be constructed, depending on site conditions and the type of activities.

Water Removal

The removal of water from the excavated area can be accomplished by numerous methods. The most common of these are:

- Gravity drain through a daylight channel
- Mechanical pumping
- Siphoning
- Using the appropriate construction equipment to scoop and dump water from the excavation

Stabilize channels or any conveyance feature dug for discharging water from the excavated area. If flow velocities cause erosion within the channel, install a ditch lining, such as geotextile or heavy plastic sheeting.

Discharge Structure

Water conveyed by channels, ditches, pumps, hose, or equipment buckets should be discharged in a regulated manner to a stable structure. The structure must:

- Be appropriate to filter sediment.
- Be able to withstand the velocity of the discharged water to prevent erosion.
- Be sized and operated such that pumped water will flow through an energy dissipation device and be converted to gravity flow prior to discharge to a downstream system.
- Not overtop the structure.

Typical constructed areas are:

- Sediment traps (refer to BMP E3.40)
- Portable sediment tanks (refer to BMP E3.50)
- Enclosure of hay bales, filter fabric (refer to BMP E3.10), or both
- Sediment filter bag

Sediment Removal – General

Sediment must be settled prior to discharge. All settling systems should be engineered and adequately sized for site conditions. Sediment removal is required when establishing wells for well-point dewatering but may be removed once the well and filter pack are established and the discharge is found to be clean and non-turbid. General settling and filtering options include the following:

- Containment in a pond structure for a minimum of 4 hours or until water is clear (time will vary greatly depending on gradation of sediment). Place a pump in a gravel bed at the bottom of the pond.
- Discharge to a manufactured or pre-made structure specifically designed for sediment removal, such as a Silt Sak, Silt Bag, or other similar product. Pump to a settling tank with sampling ports.
- Transport off site in a vehicle, such as a vacuum flush truck, for legal disposal.
- Filter through a sieve or other filter media (e.g., swimming pool filter). Simple onsite filter systems can be constructed, including wrapping the ends of the suction and discharge pipes with filter fabric, discharging through a series of drums filled with

successively finer gravel and sand, and other filtering techniques like those described under inlet protection (BMP E3.25).

- If the groundwater is contaminated, an engineered filtration treatment system is required. Refer to Section 4.3.8. BMP E3.60 Construction Stormwater Filtration for the storage tank or pond and filtration system sizing criteria.
- Manufactured bags, polymers, or other systems. These systems do not always work on fine clay soils and will only be allowed for use where approved. Chemical treatments should have state approval before they are used (refer to Ecology BMP C250 Construction Stormwater Chemical Treatment).
- Line or protect the flow path in some way to prevent mobilization of additional sediment.
- Dry and reuse filtered material on site in a mixture with other site soils, or appropriately dispose of the material based on nature and levels of any contaminants present.

Vegetated Buffer

A well-stabilized, onsite, vegetated area may serve as a dewatering facility if the area is appropriate to filter sediment and at the same time withstand the velocity of the discharged water without erosion. The discharge of sediment-laden water onto a vegetated area must not pose a threat to the survival of the existing vegetative stand through smothering by sedimentation.

Direct discharge of lightly sediment-bearing water into well-buffered areas with a 2 percent slope may be possible as long as a method of spreading flow into sheet flow is available.

Straw Bale/Filter Fabric Pit

An excavated or bermed sedimentation pond or structure can also be created using straw bale and filter fabric (refer to BMP E3.10 Filter Fence) to create a pit. Flow to the structure may not exceed the sediment removal structure's capacity to settle and filter flow or the structure's volume capacity. Wherever possible, the structure should also discharge to a well-vegetated buffer through sheet flow, should maximize the distance to the nearest receiving water, and should reduce the slope of the buffer area. Also, the excavated portion may need to be lined with geotextile material to help reduce scour and to prevent the inclusion of soil from within the structure (refer to BMP E3.40 Sediment Trap).

Sediment Filter Bag

The filter bag should be constructed of non-woven geotextile material that will provide adequate filtering ability to capture larger soil particles from the pumped water. The bag should be constructed so there is an inlet neck that may be clamped around the dewatering pump discharge hose so that all of the pumped water passes through the bag.

The filter bag should be used in combination with a straw bale or filter fence pit when located within 50 feet of a receiving water. When the distance is greater than 50 feet, the bag may be placed on well-established vegetation or on an aggregate pad constructed of crushed rock at a minimum depth of 6 inches. The bag should never be placed on bare soil.

The capacity of the sediment filter bag should be adequate to handle the dewatering pump discharge and be based on the bag manufacturer's recommendation.

When used in conjunction with a straw bale or filter fence pit, a filter bag may be operated until the water in the pit reaches the crest of the emergency overflow. The pump must be shut off at this point. When placed on either a rock pad or well-established vegetation, the bag may be operated until the discharge from the bag reaches a receiving water. Unless the discharge is at least as clear as the receiving water, the pump must be shut off at this point.

When the bag has been completely filled with sediment, it should be cut open, re-graded in place, and immediately stabilized with either sod or erosion control mat.

Maintenance

- Check filtering devices frequently to make sure they are unclogged and operating correctly. Pay special attention to the buffer area for any sign of erosion and concentration of flow that may compromise the buffer area. Where possible, observe the visual quality of the effluent and determine if additional treatment can be provided.
- Make adjustments depending on the amount of sediment in the water being pumped.
- Repair or replace any equipment that does not function as designed.
- The accumulated sediment removed during maintenance must be spread on site and stabilized or disposed of at an approved disposal site.
- Systems should be filled in or otherwise removed when permanent dewatering controls are in place and connected to an approved treatment and receiving system.

CHAPTER 5 – Source Control & Monitoring Practices for Construction Pollutants Other than Sediment

5.1. Source Control Practices

The City of Seattle (City) is committed to protecting the public drainage system or public combined sewer, ponds, wetlands, lakes, streams, and coastal and estuarine water bodies from damage by sediment and other pollutants generated during construction activities. The focus of *Chapter 4* was erosion and sediment control; however, potential pollutants other than sediment are common at project sites and may also impact stormwater and groundwater quality when they come into direct contact with runoff.

Potential pollutants include non-hazardous materials such as wood, paper, demolition debris, concrete, and metal scraps. There are also potential pollutants from hazardous materials and their associated wastes such as pesticides (e.g., insecticides, fungicides, herbicides, rodenticides), petrochemicals (e.g., oils, gasoline, asphalt degreaser), and other construction chemicals such as concrete products, sealer, paints, and washwater associated with these products.

The most economical and effective controls for pollutants other than sediment are good “housekeeping” practices and an awareness by construction workers, planners, engineers, and developers of the need for and purpose of compliance with federal, state, and local regulations.

Please refer to the Stormwater Code and *Volume 4 – Source Control* for further information concerning controlling pollution at the source and preventing contamination of stormwater for all discharges. This volume should be reviewed to ensure that all Director’s Rules requirements are being met for each construction project.

The standards for each individual best management practice (BMP) are divided into six sections:

1. Description
2. Purpose
3. Conditions Where Practice Applies
4. Planning Considerations
5. Design Criteria
6. Maintenance

Note that some BMPs were divided into different sections to reflect their individual needs. As with erosion and sediment control BMPs, source control BMPs include “Conditions Where Practice Applies,” which always refers to site conditions. As site conditions change, BMPs must be changed to remain in compliance.

This chapter contains the standards and specifications for source control BMPs to properly manage construction pollutants other than sediment. They include:

- BMP C1.15: Material Delivery, Storage, and Containment (*Section 5.1.1*)
- BMP C1.20: Use of Chemicals During Construction (*Section 5.1.2*)
- BMP C1.25: Demolition of Buildings (*Section 5.1.3*)
- BMP C1.30: Building Repair, Remodeling, and Construction (*Section 5.1.4*)
- BMP C1.35: Sawcutting and Paving Pollution Prevention (*Section 5.1.5*)
- BMP C1.45: Solid Waste Handling and Disposal (*Section 5.1.6*)
- BMP C1.50: Disposal of Asbestos and Polychlorinated Biphenyls (PCBs) (*Section 5.1.7*)
- BMP C1.55: Airborne Debris Curtain (*Section 5.1.8*)
- BMP C1.56: Concrete Handling (*Section 5.1.9*)
- BMP C1.58: Concrete Washout Area (*Section 5.1.10*)
- BMP C1.59: High pH Neutralization Using CO₂ (*Section 5.1.11*)

5.1.1. BMP C1.15: Material Delivery, Storage, and Containment

Description

Best practices for all deliveries, storage, and containment of materials, liquid and solid, on a project site that may potentially pollute stormwater.

Purpose

The purpose of this BMP is to prevent, reduce, or eliminate the discharge of pollutants to the drainage system or receiving water from the delivery and storage of materials on site. This is achieved by reducing the storage of hazardous materials on site, storing materials in a designated area, and installing secondary containment.

Conditions Where Practice Applies

These procedures are recommended for use at all project sites with delivery and storage of the following materials:

- Petroleum products such as fuel, oil and grease
- Soil stabilizers and binders (e.g., Polyacrylamide)
- Fertilizers, pesticides, and herbicides
- Detergents
- Asphalt and concrete compounds
- Hazardous chemicals such as acids, lime, adhesives, paints, solvents, and curing compounds
- Any other material that may be detrimental if released to the environment

Planning Considerations

Dangerous solid wastes must be stored and handled according to special guidelines and may require a permit. Follow the regulations and requirements outlined by the Washington State Department of Ecology (Ecology) and, in some cases, King County.

Design Criteria

The following steps must be taken to minimize risk:

- Locate temporary storage area away from vehicular traffic, near the construction entrance(s), and away from drainage channels or storm drains.
- Keep Safety Data Sheets (SDS) on site for all materials stored. Keep chemicals in their original labeled containers.
- Reduce hazardous material storage on site.
- Handle hazardous materials as infrequently as possible.
- During the wet weather season (October 1 to April 30), consider storing materials in a covered area.
- Do not store chemicals, drums, or bagged materials directly on the ground. Place these items on a pallet and, when possible, in secondary containment.

- If drums must be kept uncovered, store them at a slight angle to reduce ponding of rainwater on the lids to reduce corrosion. Domed plastic covers are inexpensive and snap to the top of drums, preventing water from collecting.
- Store materials with secondary containment, such as a curbed paved area, pallets with built-in containment, or even a children's wading pool for non-reactive materials such as detergents, oil, grease, and paints. Small amounts of material may be secondarily contained in server trays or concrete mixing trays.
- Use spill prevention and control measures for maintenance, fueling, and repair of heavy equipment and vehicles. Clean contaminated surfaces immediately following any spill incident.
- Provide cover, containment, and protection from vandalism for all chemicals, liquid products, petroleum products, and other materials that have the potential to pose a threat to human health or the environment. Include secondary containment for onsite fueling tanks.

Secondary Containment Practices:

- Store all hazardous substances with a listed Reportable Quantity in approved containers and drums and in secondary containment. The list of Reportable Quantities is available on the U.S. Environmental Protection Agency's (U.S. EPA's) website (www.epa.gov/superfund).
- Provide temporary secondary containment facilities with a spill containment volume able to contain precipitation from a 25--year, 24--hour storm event plus 10 percent of the total enclosed container volume of all containers, or 110 percent of the capacity of the largest container within its boundary, whichever is greater.
- Provide sufficient separation between stored containers to allow for spill cleanup and emergency response access.
- During the wet weather season (October 1 to April 30), cover each secondary containment facility during non-working days prior to and during rain events.
- Provide secondary containment facilities that are impervious to the materials stored for a minimum contact time of 72 hours.

Maintenance

- Keep secondary containment facilities free of accumulated rainwater and spills. In the event of spills or leaks, collect accumulated rainwater and spills and place into drums. Treat these liquids as hazardous waste unless testing determines them to be non-hazardous.
- Keep material storage areas clean, organized, and equipped with an ample supply of appropriate spill cleanup material (spill kit). For spill prevention and cleanup requirements, including spill kit instructions, refer to *Volume 4 – Source Control*.

5.1.2. BMP C1.20: Use of Chemicals During Construction

Description

Best practices for control, storage, cleaning, and disposal of all chemicals used at a project site that may potentially pollute stormwater.

Purpose

A large percentage of potential pollutants from chemicals can be effectively controlled at project sites through implementation of source control and soil erosion and sedimentation control practices.

Conditions Where Practice Applies

This BMP applies to most project sites because many types of chemicals may be used during construction activities. These chemical pollutants include paints, acids, cleaning solvents, asphalt products, soil additives, concrete-curing compounds, and many others. These materials can be carried by sediment and water runoff from project sites.

Planning Considerations

Disposal of concrete products, additives, and curing compounds depends on the product. Some liquid wastes must be stored and handled according to special guidelines and may require a permit. Follow the regulations and requirements outlined by Ecology and, in some cases, King County.

Refer to *Volume 4 – Source Control* to see if additional source controls are required.

Design Criteria

- As in the case of other pollutants, good housekeeping is the most important means of controlling pollution.
- Use only the recommended amounts of chemical materials and apply them in a proper manner to further reduce pollution.
- Acid and alkaline solutions from exposed soil or rock units high in acid and alkaline-forming natural elements should be controlled using good site planning and preconstruction geological surveys. Refer to BMP C1.56 Concrete Handling. Neutralization of these pollutants often provides the best treatment.
- The City requires project site operators to adjust the pH of stormwater if necessary to prevent violations of water quality standards. Refer to BMP C1.59 High pH Neutralization Using CO₂.
- Chemicals used in batch treatment or flow-through treatment must be approved in writing by Ecology prior to use. Formal approval from the City is based on Ecology's protocols. For a list of treatment chemicals that have been evaluated and are currently approved for use by Ecology, refer to the Department's website (<https://ecology.wa.gov/Regulations-Permits/Guidance-technical-assistance/Stormwater-permittee-guidance-resources/emerging-stormwater-treatment-technologies>).

- For paint disposal, the correct method of waste clean-up varies with the material:
 - Wash-up waters from water-based paints may go into a sanitary sewer, which is regulated by the King County Industrial Waste Program 206-477-5300.
 - Wastes from oil-based paints, cleaning solvents, thinners, and mineral spirits must be disposed of through a licensed waste management firm or treatment, storage, and disposal (TSD) facility.

Maintenance

- Sealing fractures in the bedrock with grout and bentonite will reduce the amount of acid or alkaline seepage from excavations.
- Adequate treatment and disposal of concrete further reduces pollution.

5.1.3. BMP C1.25: Demolition of Buildings

Description

Methods used to protect stormwater from pollution associated with the removal of existing buildings (and clearing of the rubble) by means of controlled explosions, wrecking balls, or manual methods.

Purpose

The loose debris produced by building demolition activities can contain toxic organic compounds, metals, and suspended solids that may pollute stormwater.

Certain building materials, such as caulk and other sealants, joint materials, paint, siding, and roofing produced between about 1930 and 1980, may contain polychlorinated biphenyls (PCBs), particularly if installed between 1950 and 1980. PCB-containing building materials were more often used in commercial, industrial, and large multi-story residential buildings as well as institutional buildings such as schools, hospitals, universities, fire houses, police stations, government offices, and military sites. It is broadly recognized (e.g., by EPA, Ecology, and the California Water Resources Control Board) that PCB-containing materials are at greater risk of being dislodged during demolition and renovation activities. If not properly managed and contained during these activities, particles containing PCBs can be washed into stormwater, contaminating the conveyance system and downstream water bodies.

This BMP is designed to help prevent the migration of PCBs that may be present in buildings undergoing demolition to the stormwater drainage system and downstream waterbodies.

Projects, regardless of size, must implement practices to properly handle and dispose of materials that may contain PCBs, such as transformers, light ballasts, caulk, paint, sealants, siding, and some roofing materials, so that they do not come into contact with stormwater.

Conditions Where Practice Applies

Complete or partial building demolition, structure demolition, or other activity that requires controlled explosions, wrecking balls, or manual methods to demolish a structure, or clearing of demolition rubble.

Planning Considerations

This BMP is intended to provide basic information to protect stormwater from being polluted by demolition debris. However, demolition of buildings is regulated in Washington by Ecology and the Puget Sound Clean Air Agency (PSCAA). Refer to Ecology's Construction and Demolition web page for additional requirements (<https://ecology.wa.gov/Regulations-Permits/Guidance-technical-assistance/Dangerous-waste-guidance/Common-dangerous-waste/Construction-and-demolition>) and PSCAA's website for other information and requirements (www.pscleanair.gov/185/Asbestos).

PCB-specific Considerations:

Seattle's extensive PCB source tracing experience suggests that industrial, commercial, institutional, and large multi-family residential structures built or renovated between 1950 and 1980 that are not wood-framed should be suspected of containing some PCB-containing

materials on their exterior. During the project planning phase, follow Ecology's guidance document *How to Find and Address PCBs in Building Materials* (Ecology 2024) to assess the likelihood that a building which will undergo demolition contains PCBs. The outcomes of the assessment can help guide whether sampling should be conducted to confirm the presence of PCB-containing materials, and at what levels, as well as the types of pollution prevention BMPs to implement.

Parties planning demolition activities should also refer to federal and state waste disposal regulations applicable to PCBs. The suspected or confirmed presence of PCB-containing building materials must be disclosed to the City's inspector at the First Ground Disturbance inspection or any pre-construction meetings prior to beginning demolition.

Design Criteria

- Identify, remove, and properly dispose of hazardous substances from the building before beginning demolition activities that could expose them to stormwater. Such substances could include PCBs, asbestos, lead paint, mercury switches, and electronic waste.
- When PCB-containing building materials are suspected or confirmed, implement the following BMPs:
 - Installing catch basin filter inserts or covers.
 - Dry vacuuming or dry sweeping adjacent hard surfaces (a dry vacuum system is preferred).
 - Preventing washwater or irrigation water from coming into contact with the PCB-containing building materials.
 - Educating landscaping and maintenance staff about avoiding the use of leaf blowers around the building.
 - Routinely visually survey the areas where PCB-containing building materials are suspected or confirmed to exist to check they have remained intact. If weathering (e.g., flaking, peeling) becomes noticeably worse as demolition continues, install additional BMPs as needed to prevent PCB discharges to the drainage system or surface waters.
- Never re-use or recycle PCB-contaminated construction materials. Keep this waste segregated from other materials and dispose of PCB-contaminated materials including, but not limited to, concrete, masonry, roofing, and siding, in accordance with EPA's Toxic Substances Control Act (TSCA) regulations and state waste regulations.
- Protect the drainage system from sediment-laden runoff and loose particles. Use inlet protection, drain covers, straw wattles, or compost socks to protect drainage inlets. To the extent possible, use dikes, berms, or other methods to protect overland discharge paths from runoff. During the workday, provide drain covers to keep dust and debris out of the drainage system and remove them at the end of the workday.
- Provide filter fence or other measures along the boundaries of disturbance. If there is more than 10,000 square feet of land-disturbing activity associated with the demolition project, direct runoff to a sediment trap or portable sediment tank prior to discharge.
- If the existing concrete slab for a demolished building will remain in place, provide permanent or interim measures to direct the runoff to an existing or new drainage

inlet structure within the site unless the slab will sheet flow across a vegetated flow path that meets the requirements of Volume 3, Section 5.3.5. Sheet Flow Dispersion. Do not allow building slab drainage to sheet flow directly across public sidewalks. If a building plumbing system will be converted into a drainage system, it must be demonstrated to meet the Side Sewer Code (SMC 21.16) and all Director's Rules published under this code. Provide inlet protection until the site is completely stabilized.

- Sweep street gutters, sidewalks, driveways, and other paved surfaces in the immediate area of the demolition daily to collect and properly dispose of loose debris and garbage.
- Lightly spray water (e.g., from a hydrant or water truck) to help control windblown fine materials such as soil, concrete dust, and paint chips. Control the amount of water so that runoff from the site does not occur, yet dust control is achieved. Never use oils for dust control.
- If feasible, construct a screen to prevent stray building materials and dust from escaping the area during demolition. Size and orient the screen to capture wind-blown materials and contain them on site.
- Schedule demolition during a dry time of year.
- Follow the guidance document *How to Find and Address PCBs in Building Materials* (Ecology 2024) for PCB-containing building materials undergoing demolition.
- Educate employees about the need to control site activities to prevent stormwater pollution and also train them in spill cleanup procedures.
- After demolition, stabilize the site using temporary or permanent cover practices (refer to Section 4.1). If the soils are contaminated, the site must be stabilized in a way to prevent runoff from coming into contact with the contaminated soils and discharging from the site.
- If crushed, rubblized, or recycled concrete is used to stabilize the site or to shore up basement walls that remain, use measures to prevent stormwater and groundwater from coming into contact with the concrete or collect the stormwater and groundwater and treat it to maintain a pH between 6.5 and 8.5 prior to discharging from the site.
- If stormwater or groundwater will be allowed to pond on the site after demolition, the following will be required:
 - Provide an overflow from the ponded area to an approved point of discharge.
 - All setbacks, site considerations, fencing requirements, embankment and failure analyses, and dam safety measures that are required for Detention Ponds must be met. Refer to Volume 3, Section 5.7.1.
 - Refer to Volume 1, Section 2.4.7 for considerations if the site has known or potential for contaminated soils or groundwater.

Maintenance

- Clean up debris on a regular basis to prevent stormwater contamination.
- Place stormdrain covers (or devices) at the beginning of the workday, then collect and properly dispose of the materials accumulated before removing the covers (or devices) at the end of the workday.

5.1.4. BMP C1.30: Building Repair, Remodeling, and Construction

Description

Best practices for the control of pollutants associated with construction of buildings and other structures such as, but not limited to, remodeling of existing buildings and houses, and general repair work on building exteriors.

Purpose

Pollutants of concern may be generated during building repair, remodeling, and construction, including petroleum hydrocarbons, toxic organic compounds (such as polychlorinated biphenyls, or PCBs), suspended solids, metals, pH, and oils and greases.

Certain building materials, such as caulk and other sealants, joint materials, paint, siding, and roofing produced between about 1930 and 1980, may contain polychlorinated biphenyls (PCBs), particularly if installed between 1950 and 1980. PCB-containing building materials were more often used in commercial, industrial, and large multi-story residential buildings as well as institutional buildings such as schools, hospitals, universities, fire houses, police stations, government offices, and military sites. It is broadly recognized (e.g., by EPA, Ecology, and the California Water Resources Control Board) that PCB-containing materials are at greater risk of being dislodged during repair and remodeling activities. If not properly managed and contained during these activities, particles containing PCBs can be washed into stormwater, contaminating the conveyance system and downstream water bodies. This BMP is designed to help prevent the migration of PCBs that may be present in buildings undergoing remodeling and repair to the stormwater drainage system and downstream waterbodies.

Conditions Where Practice Applies

When buildings and structures are repaired, remodeled, and constructed.

Planning Considerations

Educating employees about the need to control site activities is one of the most effective methods to prevent stormwater pollution. Employees may include maintenance and landscaping staff working around buildings with exterior PCB-containing materials.

The focus of planning and education is to prevent pollutant-containing dust and solids from entering stormwater and stormwater conveyances.

Seattle's extensive PCB source tracing experience suggests that industrial, commercial, institutional, and large multi-family residential structures built or renovated between 1950 and 1980 that are not wood-framed should be suspected of containing some PCB-containing materials on their exterior. During the project planning phase, follow Ecology's guidance document *How to Find and Address PCBs in Building Materials* (Ecology 2024) to assess the likelihood that a building which will undergo renovation contains PCBs. The outcomes of the assessment can help guide whether sampling should be conducted to confirm the presence of PCB-containing materials, and at what levels, as well as the types of pollution prevention BMPs to implement. Inform the City's permitting group of the suspected or confirmed presence of PCB-containing building materials prior to commencing remodeling or repair activities.

Design Criteria

- Identify, remove, and properly dispose of hazardous substances from the building before beginning renovation activities that could expose them to stormwater. Such substances could include PCBs, asbestos, lead paint, mercury switches, and electronic waste.
 - Never re-use or recycle PCB-contaminated construction materials. Keep this waste separated from other materials and dispose of PCB-contaminated materials including, but not limited to, concrete, masonry, roofing, and siding in accordance with EPA's Toxic Substances Control Act (TSCA) regulations and state waste regulations.
- Follow the guidance document *How to Find and Address PCBs in Building Materials* (Ecology 2024) for PCB-containing building materials undergoing renovation.
- Use ground cloths or drop cloths underneath activities.
- Use drain covers or similarly effective devices if dust, grit, washwater, or other pollutants may impact onsite or downstream offsite catch basins. If covers are used, place them on the storm drains at the beginning of the workday and remove them at the end of the workday. Collect and dispose of the accumulated sediment-laden runoff and solids before the cover is removed. If storm drain covers are not feasible, install and maintain filter inserts in all catch basins that may receive stormwater from the work site (i.e., on the work site property and adjacent street(s)).
- Clean all tools and brushes covered with water-based paints in an inside sink that drains to the sanitary sewer. If cleaning must be done outside, collect all wastewater and dispose of properly.
- Clean non-water-based finishes from tools in a manner that allows the collection of used solvents for recycling or proper disposal. Do not discharge non-water-based finishes or paints or used solvents into the sanitary sewer or any other drain.
- Water can be lightly sprayed to help control windblown fine materials such as soil, concrete dust, and paint chips. Control the amount of water so that runoff from the site does not occur, yet dust control is achieved. Never use oils for dust control.
- When removing suspected PCB-containing materials, avoid working in high wind conditions or take extra precautions when working in wind strong enough to move dust and debris. Precautions could include constructing a wind screen of plastic at the edge of the groundcover to keep dust and debris from spreading. To the extent practical, use tools and work methods that generate the least dust and heat. Consider using manual tools as they generate less fine dust and heat.
- In the Shoreline District, as defined by SMC Chapter 23.60A Seattle Shoreline Program Regulations, comply with the provisions of SMC 23.60A.152 and SMC 23.60A.155 or the current Shoreline Master Program code.
- Construction and repair work must use BMPs to prevent the entry of debris and other waste materials into any water body. Any cleaning, sanding, cutting of treated wood, or resurfacing operation occurring over water or in water must be performed with tarpaulins, decking, or similarly effective materials securely attached above the water line to prevent material from entering the water. Before the tarpaulins, decking, or similarly effective materials are removed, the accumulated contents must be removed by vacuuming or an equivalent method that prevents material from entering the

water. Use dry methods to sweep the area daily to collect loose litter, paint chips, grit, and dirt.

- Use a HEPA vacuum below painted walls, caulking seams, windows, doors, downspouts, and any specific exterior features known or suspected of containing PCBs.
- No over-water or in-water application of paint, preservative treatment, or other chemical compounds is permitted, except in accordance with BMPs to prevent the compounds from entering the water.
- In addition to the BMPs that prevent debris and chemical compounds from construction, remodeling, and repair work from entering water bodies, a secondary containment system (e.g., floating containment boom) is required for work over water or in water. Additional requirements may apply, as required by local, state, and federal regulations.
- At all times, have spill cleanup materials appropriate to the chemicals used on site available at the work site.
- Construction staging areas must be as far from the water bodies on the site as possible.

Maintenance

- Place storm drain covers (or devices) at the beginning of the workday, then collect and properly dispose of the materials accumulated before removing the covers (or devices) at the end of the workday.
- Clean up the work site at the end of each workday. Put away materials (such as solvents) indoors or cover and secure them, so that unauthorized individuals will not have access to them.
- Maintain drain covers regularly (weekly or as needed) to prevent plugging.
- Recycle materials whenever possible, except when materials are contaminated by pollutants. PCB-containing materials should never be reused or recycled for reintroduction to the construction industry.

5.1.5. BMP C1.35: Sawcutting and Paving Pollution Prevention

Description

Best practices to minimize and eliminate wastewater and slurry from sawcutting and paving operations including, but not limited to, the following:

- Sawing
- Surfacing
- Coring
- Grinding
- Roughening
- Hydro-demolition
- Bridge and road surfacing

Purpose

Sawcutting and paving operations generate slurry and wastewater that contain fine particles and high pH, both of which can violate the water quality standards in receiving waters.

Conditions Where Practice Applies

Any time sawcutting or paving operations take place.

Planning Considerations

This BMP is intended to minimize and eliminate wastewater and slurry from entering the public drainage control system and receiving waters. Wastewater may be permitted to be discharged to a sanitary sewer, which is regulated by Seattle Public Utilities and the King County Industrial Waste Program (206-477-5300).

Design Criteria

- Vacuum slurry and cuttings during the activity to prevent migration off site. Do not allow slurry and cuttings to remain on permanent concrete or asphalt paving overnight.
- Dispose of collected slurry and cuttings in a manner that does not violate groundwater or surface water quality standards.
- Do not drain wastewater generated during hydro-demolition, surface roughening, or similar operations to any natural or constructed drainage conveyance. Dispose of wastewater in a manner that does not violate groundwater or surface water quality standards.
- Clean and dispose of waste material and demolition debris in a manner that does not cause contamination of water. If the area is swept with a pick-up sweeper, haul out the material to an appropriate disposal site.

Maintenance

Continually monitor operations to determine whether slurry, cuttings, or wastewater could enter the public drainage system or the public sewer. If inspections show that a violation of water quality standards could occur, stop operations and immediately implement preventative measures such as berms, barriers, secondary containment, and vacuum trucks.

5.1.6. BMP C1.45: Solid Waste Handling and Disposal

Description

Methods used to protect stormwater from pollution associated with the management, handling, and disposal of all solid waste generated on a project site.

Purpose

Solid waste is one of the major pollutants caused by construction and can have direct impacts to stormwater as a potential pollutant if not managed and disposed of properly. Solid waste includes the following:

- Trees and shrubs removed during land clearing
- Wood and paper used in packaging and building materials
- Scrap metals and metal shavings
- Sanitary wastes
- Rubber, plastic, and glass pieces
- Masonry products
- Leftover food, food containers, beverage cans, coffee cups, lunch wrapping paper, aluminum foil, and plastic
- Cigarette packages and butts
- Unwanted or discarded construction and demolition products

Conditions Where Practice Applies

All project sites.

Refer to BMP C1.50 for PCB-containing waste and debris.

Planning Considerations

The major control mechanism for these pollutants is to provide adequate disposal facilities.

Design Criteria

- Collection containers: Project sites should have at least two collection containers: one for garbage or non-recyclable construction wastes and another for recycling. Multiple containers for source-separated recyclables, such as clean wood and metal, are encouraged. Source-separating recyclables on the site means more recycling, less waste, and generally lower tipping fees and disposal costs. All containers located on the job site should be clearly marked, labeled with a list of acceptable materials, and kept closed when not in use. Any container designated for recycling should have at least 90% of its contents be recyclable and no garbage or items not accepted by the receiving facility. Garbage should not be deposited in a container designated for construction waste or for recycling.
- Remove garbage frequently to maintain project sites in a clean and attractive manner. Remove and dispose of accumulated solid waste at authorized disposal areas.

- Label waste containers and locate them in a covered area. Keep lids closed at all times.
- The City requires the recycling of readily recyclable construction and demolition waste materials and submittal of a Waste Diversion Report per SMC 21.36.089 and subsequent SPU Director's Rules related to construction materials disposal bans. In addition, the Seattle Department of Construction and Inspection now requires that a Waste Diversion Plan be part of the permit application for a building permit if the project is 750 square feet or greater and that a Salvage Assessment be performed for any job involving demolition. At the end of each project, a Waste Diversion Report must be submitted to Seattle Public Utilities that documents through facility weight receipts where materials from the construction or demolition site went for reuse, recycling, and disposal.
- Reuse and Recycling: Reuse on and off site reduces waste and is the preferred method for handling materials. Several local firms provide salvage assessment and resale of building materials. Green building credits recognize reuse as well as recycling.
- Hauling: Reusables and recyclables may be hauled by any company you choose or you may "self-haul" yourself. Non-recyclable construction waste such as painted and treated wood or fiberglass insulation must be hauled only by the City's contracted hauler, Waste Management, or you may "self-haul" to the appropriate receiving facility.
- Recyclable Materials from Project Sites: Current and future targeted materials and their handling, hauling, and destination requirements are listed in Table 9.
- For more information about the City's construction and demolition waste recycling requirements, refer to the City's website (www.seattle.gov/utilities/businesses-and-key-accounts/construction/construction-waste).
- For assistance with finding recycling facilities, refer to the King County Green Tools web page (<https://kingcounty.gov/depts/dnrp/solid-waste/programs/green-building.aspx>).
- For assistance in determining where to take motor oil, pesticides, smoke alarms, fluorescent bulbs, and other hazardous materials, refer to the Local Hazardous Waste Management Program website (www.hazwastehelp.com).
- Selective (rather than wholesale) removal of trees is helpful in conservation of soil and reduction of wood wastes. Avoid indiscriminate removal of trees and other beneficial vegetation.

Table 9a. Handling, Hauling, and Destination Requirements for Targeted Materials.

Targeted Materials	Banned from Disposal	Collection Method and Hauling	Facilities^a
Land Clearing (such as trees, shrubs, stumps)	Yes	<ul style="list-style-type: none"> • Self-haul or • Order drop box from a private recycler • Grind and use on site 	<ul style="list-style-type: none"> • City transfer stations • Private drop sites for yard waste • Composting facilities • Wood waste recyclers
Asphalt Paving	Yes	<ul style="list-style-type: none"> • Self-haul or • Order drop box from a private hauler or recycler 	<ul style="list-style-type: none"> • Concrete recyclers • Sand and gravel operations • Mixed waste recyclers
Bricks	Yes, if whole	<ul style="list-style-type: none"> • Reuse on or off site • Self-haul to a reuse store or private recycler 	<ul style="list-style-type: none"> • Reuse stores • Sand and gravel operations
Concrete	Yes, if unpainted	<ul style="list-style-type: none"> • Reuse on or off site as fill only if appropriate for groundwater conditions • Self-haul 	<ul style="list-style-type: none"> • Concrete recyclers, • Sand and gravel operations • Mixed waste recyclers
Cardboard and Paper	Yes	<ul style="list-style-type: none"> • Use City-provided curbside recycling containers or commercial recycling cart service if available for the building site • Self-haul 	<ul style="list-style-type: none"> • City transfer stations • Many private recyclers
Metal (ferrous and non-ferrous)	Yes	<ul style="list-style-type: none"> • Use City-provided curbside recycling container if available for building site • Self-haul 	<ul style="list-style-type: none"> • City transfer stations • Many private recyclers
New Construction Gypsum Scrap	Yes	<ul style="list-style-type: none"> • Self-haul • Drop box from a private recycler 	<ul style="list-style-type: none"> • Drywall recyclers • Mixed waste recyclers
Carpet	Yes, starting in July 2022 ^b	<ul style="list-style-type: none"> • Self-haul • Drop box from a private hauler or recycler 	<ul style="list-style-type: none"> • Take back offered through flooring stores for installers • Some mixed waste recyclers if clean
Plastic Film Wrap	Yes, starting in July 2022 ^b	<ul style="list-style-type: none"> • Self-haul • Drop box from a private hauler or recycler 	<ul style="list-style-type: none"> • Mixed waste recyclers if clean
Wood	Yes, if unpainted and untreated wood over 6 inches in length	<ul style="list-style-type: none"> • Self-haul • Drop box from a private hauler or recycler 	<ul style="list-style-type: none"> • City transfer stations • Private drop sites and recycling facilities
Tear-off Asphalt Roofing Shingles	Yes, starting in July 2022 ^b	<ul style="list-style-type: none"> • Self-haul to a private recycler 	<ul style="list-style-type: none"> • Private asphalt shingle recyclers • Some mixed waste recyclers

Table 9b. Handling, Hauling, and Destination Requirements for Targeted Materials.

Targeted Materials	Banned from Disposal	Collection Method and Hauling	Facilities*
Food Waste (such as from lunches)	Yes for food but not the wrappings or containers	<ul style="list-style-type: none"> Use City-provided curbside organics container or commercial cart service if available for the building site 	
Tin and Aluminum Cans, Glass and Plastic Bottles and Jars	Yes	<ul style="list-style-type: none"> Use City-provided curbside recycling container or commercial recycling cart service if available for the building site Self-haul 	<ul style="list-style-type: none"> City transfer stations Private recyclers
Cups	Yes	<ul style="list-style-type: none"> Use City-provided curbside recycling container or commercial recycling cart service if available for the building site 	<ul style="list-style-type: none"> City transfer stations Private recyclers
Other Non-Recyclable Waste Materials		<ul style="list-style-type: none"> Self-haul to City transfer stations for disposal Order a container from Waste Management, the City's contractor for the hauling of non-recyclable construction wastes at 1--800--592-9995 	<ul style="list-style-type: none"> Self-haul to City transfer stations for disposal Order a container from Waste Management, the City's contractor for the hauling of non-recyclable construction wastes at 1--800--592-9995

^a For a list of construction waste recycling facilities, refer to the City's website (www.seattle.gov/utilities/businesses-and-key-accounts/construction/construction-waste/recycling-requirements/certified-facilities).

^b Refer to Director's Rule SW-640 (formerly DR SW-405.3) for the effective date for bans on carpet, plastic film wrap, and tear-off asphalt roofing shingles.

Maintenance

Soil erosion and sediment control structures capture much of the solid waste from project sites. Frequently remove litter from these structures to reduce the amount of solid waste littering the landscape.

5.1.7. *BMP C1.50: Disposal of Asbestos and Polychlorinated Biphenyls (PCBs)*

Use and disposal of these potential pollutants are regulated by both state and federal agencies. For further information, contact:

- For asbestos:
 - Puget Sound Clean Air Agency (<https://pscleanair.gov>) (206) 343--8800 or toll-free (800) 552--3565
 - U.S. EPA (www.epa.gov/asbestos) (206) 553-1200 or toll-free (800) 424--4EPA
- For wastes containing PCBs:
 - Washington Department of Ecology - Hazardous Waste Toxics Reduction Program. Contact Ecology's Northwest Regional Office at 206-594-0000. PCBs are regulated under Chapter 173-303 WAC (Washington Administrative Code), Dangerous Waste Regulations. For background information about PCBs as a Dangerous Waste, refer to Ecology Publication 21-04-034.
 - U.S. EPA - Region 10 PCB Program (<https://www.epa.gov/pcbs/region-10-pcb-program>) . Region 10 PCB Coordinator: 206-553-2899. More information about EPA-regulated PCB disposal can be found here: <https://www.epa.gov/pcbs/disposal-and-storage-polychlorinated-biphenyl-pcb-waste>.

5.1.8. *BMP C1.55: Airborne Debris Curtain*

Description

Using plastic or other material to create a vertical barrier, or curtain, around a building or other structure undergoing exposed construction or cleaning activities to minimize the spread of airborne debris.

Purpose

Activities related to exposed building construction, repair, or cleaning include spraying, pressure washing, surface preparation, sand blasting, paint removal, sanding, and painting. If conducted outdoors, all of these activities are associated with high risk for contaminating water resources.

Potential pollutants include spent fire retardants, abrasive grits, solvents, oils, washwater, paint overspray, cleaners and detergents, paint chips, glass fibers, and dust. Pollutant constituents include suspended solids, oils and greases, organic compounds, copper, lead, tin, and zinc.

Conditions Where Practice Applies

This BMP should be implemented when spraying, blasting, sanding, or washing outdoors.

Planning Considerations

- Relocate maintenance and repair activities that can be moved indoors to reduce the potential for direct pollution of stormwater.
- Evaluate disposal methods for spent abrasives, cleaners, etc.
- Consider using no soaps or detergents. Brush the exterior surface with water only.

Despite what is on the label, the term biodegradable does not mean that the product is safe or environmentally friendly. Some cleaning products may degrade eventually but are still harmful to the environment.

Design Criteria

- Use fixed platforms with appropriate plastic or tarpaulin barriers as work surfaces and for containment when work is performed near a receiving water. This helps to prevent material or overspray from coming into contact with stormwater or the receiving water.
- Use sanders that have dust-containment bags and avoid sanding in windy conditions.
- Store materials such as paints, tools, and ground cloths indoors or in a covered area when not in use.
- Contain blasting and spraying activities by hanging tarpaulins to block the wind and prevent dust and overspray from escaping. Do not perform uncontained spray painting, blasting, or sanding activities over open water without proper protection (e.g., overspray collection, drop cloths, booms).
- Use plywood or plastic sheeting to cover open areas when sandblasting.

- During painting, finishing, or sand blasting, use ground cloths to collect drips, spills, paint chips, and used blasting sand.
- Avoid collecting debris in areas subject to foot or vehicular traffic to control tracking.

Maintenance

- Collect spent abrasives and other waste materials regularly. Contain and store them under cover until they can be disposed of properly.
- At least once each week or more often as needed, sweep and clean ground surface areas. Do not hose them down. Properly dispose of the collected materials.
- Use one of the following treatment BMPs when paint chips or blasting grit are present in the work area:
 - Cleaning Inlets and Catch Basins (BMP E3.65)
 - Street Sweeping and Vacuuming (BMP E3.70)
 - Inlet Protection (BMP E3.25). Use filtration with media designed for the pollutants present.

Catch basin filters only remove solids and do not provide treatment for other pollutants associated with some building cleaning activities.

5.1.9. BMP C1.56: Concrete Handling

Description

Concrete work includes storage, mixing, pouring, placement, finishing, removal, saw cutting, and cleanup of concrete materials, slurry, or process water associated with these activities.

Purpose

To prevent or reduce the discharge of fine particles and high pH process water and slurry from concrete materials. Concrete spillage or concrete discharge to waters of the state is prohibited.

Conditions Where Practice Applies

Any time concrete is used, removed, or disposed of, including, but not limited to, placement and maintenance of:

- Curbs
- Sidewalks
- Roads
- Bridges
- Foundations
- Floors
- Runways

Any time cured or uncured concrete is used, removed or disposed of, or water that has come in contact with uncured concrete is present, it must be disposed of properly. Activities that use, remove, or dispose of concrete include, but are not limited to, sawing slurry, coring, grinding, roughening, hydro-demolition, and bridge and road surfacing.

Planning Considerations

Washwater and stormwater that has contacted uncured cement will become high-pH waters, which must be collected and treated before release to the public drainage system or public combined sewer. Concrete should not be placed during heavy rain events.

Wash concrete truck drums and other concrete handling equipment at an approved offsite location or in designated concrete washout areas only. Do not wash out concrete trucks on the ground (including formed areas awaiting concrete) or into storm drains, open ditches, streets, or streams. Refer to BMP C1.58 for information on concrete washout areas.

Refer to BMP C1.59 for pH adjustment requirements. Refer to Section 5.1.11 and, if applicable, the Construction Stormwater General Permit for pH monitoring requirements if the project involves one of the following activities:

- Significant concrete work (greater than 1,000 cubic yards poured concrete or recycled concrete used over the life of a project).

- The use of engineered soils amended with, but not limited to, Portland cement-treated base, cement kiln dust, or fly ash.
- Discharge of stormwater to receiving waters on the 303(d)list (Category 5) for high pH.

Education:

- Discuss the concrete management techniques described in this BMP with the ready-mix concrete supplier before any deliveries are made.
- Educate employees and subcontractors on the concrete waste management techniques described in this BMP.
- Arrange for contractor's superintendent or CESCL to oversee and enforce concrete waste management procedures.
- Install a sign adjacent to each temporary concrete washout area (BMP C1.58) to inform concrete equipment operators about utilizing the proper facilities.

Contracts:

Incorporate requirements for concrete waste management into concrete supplier and subcontractor agreements.

Design Criteria

- Within 15 feet of receiving waters, always use forms or solid barriers for concrete pours, such as pilings.
- Return unused concrete remaining in the truck and pump to the originating batch plant for recycling.
- Prefabricated containers are most resistant to damage and protect against spills and leaks. Companies may offer delivery service and provide regular maintenance and disposal of solid and liquid waste.
- Use approximately 7 gallons of washwater or less to wash one truck chute.
- Use approximately 50 gallons of washwater or less to wash out the hopper of a concrete pump truck.
- Washout facilities (BMP C1.58) should be maintained to provide adequate holding capacity with a minimum freeboard of 12 inches.
- Washout facilities (BMP C1.58) must be cleaned or new facilities must be constructed and ready for use once the washout is 75 percent full.
- Do not allow process water generated during hydro-demolition, surface roughening, or similar operations to drain to any natural or constructed drainage conveyance, including stormwater systems. Dispose of process water in a manner that does not violate groundwater or surface water quality standards.
- Wash hand tools including, but not limited to, screeds, shovels, rakes, floats, and trowels into formed areas or into a designated concrete washout area (BMP C1.58) only.

- Handle and dispose of cleaning waste material and demolition debris in a manner that does not cause contamination of water. Dispose of sweeping material from a pick-up sweeper at an appropriate disposal site.
- Wash equipment that is difficult to move, such as concrete pavers, in areas that do not directly drain to natural or constructed stormwater conveyances.
- Do not allow washdown from areas, such as concrete aggregate driveways, to drain directly to natural or constructed stormwater conveyances.
- Never wash off concrete into the footprint of an area where an infiltration feature will be installed.
- Contain washwater and leftover product in a lined container when no formed areas are available. Dispose of contained concrete in a manner that does not violate groundwater or surface water quality standards.
- The following steps will help reduce stormwater pollution from concrete wastes:
 - Do not allow excess concrete to be dumped on site, except in designated concrete washout areas.
 - If self-installed concrete washout areas are used, below-grade structures are preferred over above-grade structures because they are less prone to spills and leaks. Self-installed above-grade structures should only be used if excavation is not practical.

5.1.10. BMP C1.58: Concrete Washout Area

Description

Methods for control, containment, removal, and disposal of concrete materials and waste products to prevent contamination of storm drains, open ditches, or critical areas such as water bodies and wetlands. Concrete work includes storage, mixing, pouring, placement, finishing, removal, sawcutting, or cleanup of concrete materials, slurry, or process water associated with these activities. It also includes the proper construction of a contained area on a project site where concrete and concrete wastewater and washout may be stored for later disposal.

Purpose

Prevent or reduce the discharge of pollutants from concrete waste to stormwater by conducting washout off site or performing onsite washout in a designated area.

Conditions Where Practice Applies

Concrete washout areas are implemented on construction projects where:

- Concrete is used as a construction material.
- It is not possible to dispose of all concrete wastewater and washout off site (ready mix plant, etc.).
- Concrete truck drums are washed on site.

Note that auxiliary concrete truck components (e.g., chutes and hoses) and small concrete handling equipment (e.g., hand tools, screeds, shovels, rakes, floats, trowels, and wheelbarrows) may be washed off into formed areas awaiting a concrete pour.

At no time will concrete handling equipment be washed off into the footprint of a proposed area where an infiltration BMP will be installed.

Design Criteria

Location and Placement of Washout Areas:

- Locate washout area at least 50 feet from storm drains, open ditches, or critical areas such as water bodies and wetlands.
- Allow convenient access for concrete trucks, preferably near the area where the concrete is being poured.
- If trucks need to leave a paved area to access washout, prevent track-out with a pad of rock or quarry spalls (refer to BMP E2.10). These areas should be far enough away from other construction traffic to reduce the likelihood of accidental damage and spills.
- The number of washout facilities installed depends on the expected demand for storage capacity.
- On large sites with extensive concrete work, washout facilities should be placed in multiple locations for ease of use by concrete truck drivers.

- If the washout facility is nearing capacity, vacuum and dispose of the waste material in an approved manner.

Note: If less than 10 concrete trucks or pumpers need to be washed out on site, the washwater may be disposed of in a formed area awaiting a concrete pour or an upland disposal site where it will not contaminate surface water or groundwater. The upland disposal site must be at least 50 feet from critical areas such as storm drains, open ditches, or water bodies, including wetlands.

- Concrete washout areas must be constructed and maintained in sufficient quantity and size to contain all liquid and concrete waste generated by washout operations.

Onsite Temporary Concrete Washout Facility and Transit Truck Washout Procedures:

- Locate temporary concrete washout facilities a minimum of 50 feet from critical areas, including storm drain inlets, open drainage BMPs, and receiving waters. Refer to Figures 20 and 21.
- Construct and maintain concrete washout facilities in sufficient quantity and size to contain all liquid and concrete waste generated by washout operations.
- Perform washout of concrete trucks in designated areas only.
- Concrete washout from concrete pumper bins can be washed into concrete pumper trucks and discharged into the designated washout area or properly disposed of off site.
- Once concrete wastes are washed into the designated area and allowed to harden, break up, remove, and dispose of the concrete per applicable solid waste regulations. Dispose of hardened concrete on a regular basis.

Temporary Above-grade Concrete Washout Facility:

- Construct temporary concrete washout facilities (type above grade) (refer to Figures 20 and 21), with a recommended minimum length and minimum width of 10 feet, but with sufficient quantity and volume to contain all liquid and concrete waste generated by washout operations.
- Use plastic lining material that is a minimum of 10 mil polyethylene sheeting and free of holes, tears, or other defects that compromise the impermeability of the material.

Temporary Below-grade Concrete Washout Facility:

- Construct temporary concrete washout facilities (refer to Figure 20, type below-grade) with a recommended minimum length and minimum width of 10 feet. The quantity and volume should be sufficient to contain all liquid and concrete waste generated by washout operations.
- Use commercial type lath and flagging.
- Use plastic lining material that is a minimum of 10 mil polyethylene sheeting and free of holes, tears, or other defects that compromise the impermeability of the material.
- Install liner seams in accordance with manufacturers' recommendations.
- Prepare soil base so it is free of rocks or other debris that may cause tears or holes in the plastic lining material.

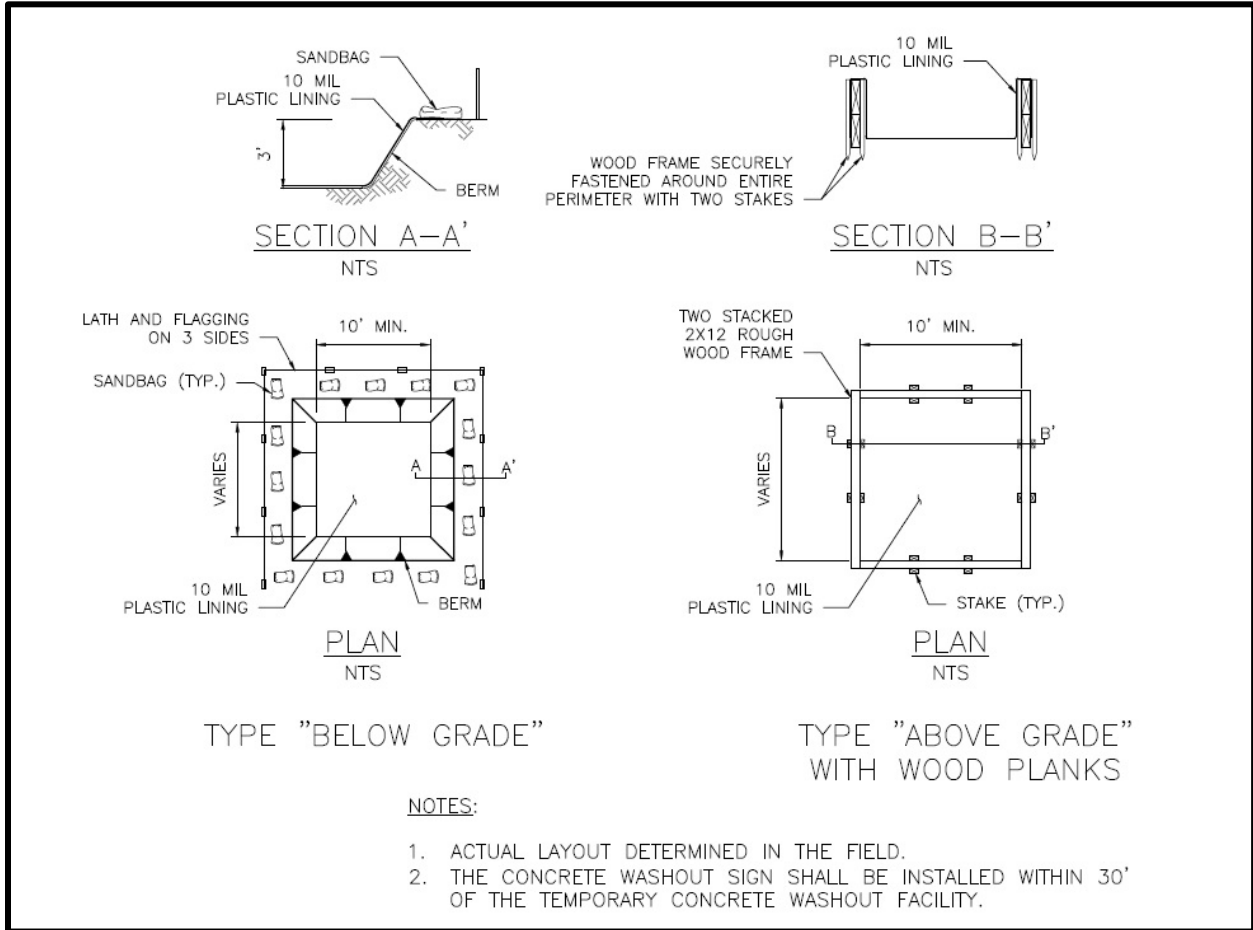

Figure 20. Concrete Washout Facility.

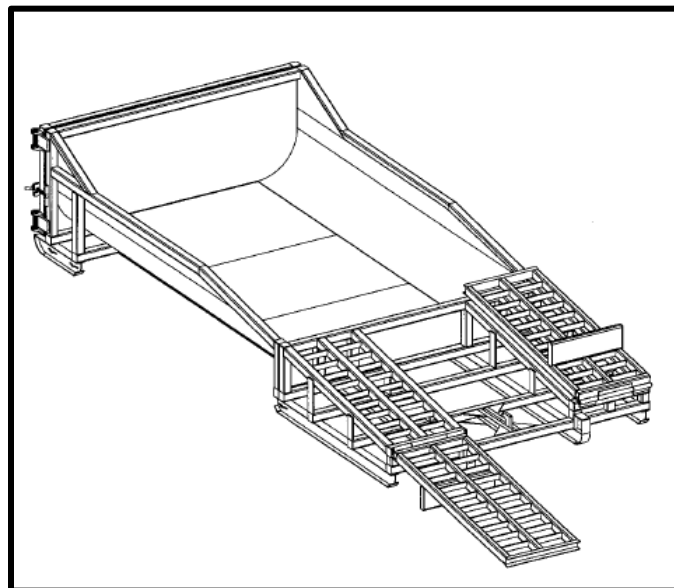

Figure 21. Prefabricated Concrete Washout Container with Ramp.

Maintenance

- Check containers daily for holes in the liner during concrete pours and repair the same day.
- Continually monitor operations to determine whether slurry, cuttings, or process water could enter receiving waters. If inspections show that a violation of water quality standards could occur, stop operations and immediately implement preventive measures such as berms, barriers, secondary containment, and vacuum trucks.
- Inspect and verify that concrete washout BMPs are in place prior to the commencement of concrete work.
- During periods of concrete work, inspect daily to verify continued performance.
- Check overall condition and performance.
- Check remaining capacity (percent full).
- If using self-installed washout facilities, verify plastic liners are intact and sidewalls are not damaged.
- If using prefabricated containers, check for leaks.
- Do not discharge liquid or slurry to receiving waters, drainage channels, storm drains, or directly onto ground.
- Do not use the public sanitary sewer without King County Industrial Waste Program approval.
- Place a secure, non-collapsing, non-water-collecting cover over the concrete washout facility prior to a predicted wet weather event to prevent accumulation and overflow of precipitation.
- Remove and dispose of hardened concrete and return the structure to a functional condition. Concrete may be reused on site or hauled away for disposal or recycling.
- When removing materials from the self-installed concrete washout, build a new structure. If the previous structure is still intact, inspect for signs of weakening or damage, and make any necessary repairs. Re-line the structure with new plastic after each cleaning.

Removal of Temporary Concrete Washout Facilities:

- When temporary concrete washout facilities are no longer required for the work, remove and properly dispose of the hardened concrete, slurries, and liquids.
- Remove and dispose of or recycle materials used to construct temporary concrete washout facilities.
- Backfill, repair, and stabilize holes, depressions, or other ground disturbance caused by the removal of the temporary concrete washout facilities to prevent erosion.

5.1.11. BMP C1.59: High pH Neutralization Using CO₂

Description

Methods for neutralization of high pH water prior to discharge into the drainage system or receiving waters.

Purpose

When pH levels in stormwater rise above 8.5 it is necessary to lower the pH levels to the acceptable range of 6.5 to 8.5, this process is called pH neutralization. pH neutralization involves the use of solid or compressed carbon dioxide gas in water requiring neutralization (CO₂ Sparging). Neutralized stormwater may be discharged to receiving waters under the Ecology Construction Stormwater General permit.

Neutralized process water, such as concrete truck washout, hydro-demolition, or sawcutting slurry, must be managed to prevent discharge to receiving waters. Any stormwater contaminated during concrete work is considered process wastewater and must not be discharged to receiving waters.

Reasons for pH Neutralization:

- A pH range of 6.5 to 8.5 is typical for most natural watercourses, and this neutral pH is required for the survival of aquatic organisms. Should the pH rise or drop out of this range, fish and other aquatic organisms may become stressed and may die.
- Calcium hardness can contribute to high pH values and cause toxicity that is associated with high pH conditions. A high level of calcium hardness in receiving waters is not allowed.
- The water quality standard for pH in Washington State is in the range of 6.5 to 8.5. The groundwater standard for calcium and other dissolved solids in Washington State is less than 500 mg/l.

Conditions Where Practice Applies

Causes of High pH:

High pH at project sites is most commonly caused by the contact of stormwater with poured or recycled concrete, cement, mortars, and other construction materials containing Portland cement or lime. (Refer to BMP C1.56 for more information on concrete handling procedures.) The principal caustic agent in cement is calcium hydroxide (free lime).

Advantages of CO₂ Sparging:

- Rapidly neutralizes high pH water.
- Cost effective and safer to handle than acid compounds.
- CO₂ is self-buffering. It is difficult to overdose and create harmfully low pH levels.
- Material is readily available.

The Chemical Process:

When carbon dioxide (CO₂) is added to water (H₂O), carbonic acid (H₂CO₃) is formed, which can further dissociate into a proton (H⁺) and a bicarbonate anion (HCO₃⁻) as shown below:



The free proton is a weak acid that can lower the pH. Water temperature has an effect on the reaction as well. The colder the water temperature the slower the reaction occurs and the warmer the water temperature the quicker the reaction occurs. Most construction applications in Washington State have water temperatures in the 50° F or higher range so the reaction is almost instantaneous.

Design Criteria

Treatment Process:

High pH water may be treated using continuous treatment, continuous discharge systems. These manufactured systems continuously monitor influent and effluent pH to ensure that pH values are within an acceptable range before being discharged. All systems must have fail safe automatic shut off switches in the event that pH is not within the acceptable discharge range. Only trained operators may operate manufactured systems. System manufacturers often provide trained operators or training on their devices.

The following procedure may be used when not using a continuous discharge system:

1. Make every effort to isolate the potential high pH water in order to treat it separately from other stormwater on site.
2. Store water in an acceptable storage facility, detention pond, or containment cell prior to treatment.
3. Transfer water to be treated to the treatment structure. Ensure that treatment structure size is sufficient to hold the amount of water that is to be treated. Do not fill tank completely, allow at least 2 feet of freeboard.
4. Sample the water for pH and note the clarity of the water. Generally, less CO₂ is necessary for clearer water. Record this information in the stormwater treatment logbook.
5. In the pH adjustment structure, add CO₂ until the pH falls in the range of 6.9 to 7.1. Remember that pH water quality standards apply so adjusting pH to within 0.2 pH units of receiving water (background pH) is recommended. It is unlikely that pH can be adjusted to within 0.2 pH units using dry ice. Compressed carbon dioxide gas should be introduced to the water using a carbon dioxide diffuser located near the bottom of the tank, which will allow carbon dioxide to bubble up through the water and diffuse more evenly.
6. Slowly discharge the water, making sure water does not get stirred up in the process. Release about 80 percent of the water from the structure leaving any sludge behind.
7. Discharge treated water through a pond or drainage system.

8. Excess sludge must be disposed of properly as concrete waste. If several batches of water are undergoing pH treatment, sludge can be left in the treatment structure for the next batch treatment. Dispose of sludge when it fills 50 percent of tank volume.

Sites that must implement flow control for the developed site must also control stormwater release rates during construction. All treated stormwater must go through a flow control facility before being released to receiving waters or systems that require flow control.

Maintenance Standards:

Safety and Materials Handling

- Handle all equipment in accordance with Occupational Safety and Health Administration (OSHA) rules and regulations.
- Follow manufacturer guidelines for materials handling.

Operator Records

Each operator should provide:

- A diagram of the monitoring and treatment equipment.
- A description of the pumping rates and treatment equipment capacity .

Each operator should keep a written record of the following:

- Client name and phone number
- Date of treatment
- Weather conditions
- Project name and location
- Volume of water treated
- pH of untreated water
- Amount of CO₂ needed to adjust water to a pH range of 6.9 to 7.1
- pH of treated water
- Discharge point location and description

A copy of this record should be given to the project proponent/owner/contractor who must retain the record for 3 years.

5.2. Monitoring Practices

5.2.1. *Turbidity Monitoring*

All Large Projects that have concentrated discharges, such as sediment tank or sediment trap discharges, to public or private storm drainage systems or surface waters are required to monitor the turbidity prior to discharge and provide additional treatment if required to meet turbidity benchmarks. Small Projects may also require turbidity monitoring if the site is suspected of causing a surface water quality standards violation. If the discharge is to a combined sewer system, then refer to the requirements of the King County Construction Dewatering Authorization.

For construction turbidity monitoring, turbidity benchmarks of 25 and 250 NTU (nephelometric turbidity unit) are used. It is presumed that turbidity of 25 NTU or less is not likely to cause an exceedance of State of Washington water quality standards under most conditions, and BMPs are presumed to be functioning properly. If a turbidity reading exceeds 25 NTU, it is presumed that necessary BMPs have not been implemented or are not functioning properly and corrective action must be taken, such as employing additional BMPs around the site, providing additional time for settling out particles, or using filtration or chemical treatment (such as chitosan, etc.) to reduce the turbidity to below 25 NTU. If the turbidity benchmark of 250 NTU is exceeded, there is a much higher risk of exceeding state water quality standards.

During construction, sampling for turbidity must be performed (i) during or after each rainfall event of at least 0.25 inches within a calendar day that results in concentrated discharge from the site, (ii) prior to any batch discharge, and (iii) at least once every calendar week when there is a discharge. Sampling is not required outside of operational hours or during unsafe conditions. No more than one sample is required in a day, and no more than two samples are required per week if the test indicates that turbidity is 25 NTU or less. If the sample indicates that turbidity is in excess of 25 NTU after the initial sample is taken or visibly turbid water is observed coming from the site, then the site must immediately begin the process to fully implement and maintain appropriate source control and/or treatment BMPs and evaluate if additional BMPs are necessary to meet the 25 NTU benchmark. If the sample test indicates that turbidity is more than 250 NTU, additional samples at least daily are required until the turbidity is 25 NTU or less. In this event, (i) immediate corrective actions must be taken to reduce turbidity levels, and (ii) the City inspector *and* Ecology (206-594-0000) must both be notified within 24 hours of becoming aware of the elevated turbidity result.

Additional monitoring requirements may apply if the project is subject to the Ecology Construction Stormwater General Permit or other Ecology-issued permits or authorizations.

5.2.2. *pH Monitoring*

pH monitoring is required for any Large Project that includes any of the following activities:

- Significant concrete work (greater than 1,000 cubic yards poured concrete or recycled concrete used over the life of a project).

- The use of engineered soils amended with (but not limited to) Portland cement-treated base, cement kiln dust, or fly ash.
- Discharge of stormwater to receiving waters on the 303(d)list (Category 5) for high pH.

Small Projects may also require pH monitoring if the site is suspected of causing a surface water quality violation.

When there are discharges from the site, sampling for pH is required at least once weekly during the following activities:

- Starting when concrete is first placed or poured and exposed to precipitation and continuing through the curing period until the stormwater pH is in the range of 6.5 to 8.5.
- For sites with recycled concrete or Portland cement-treated soils, starting when the recycled concrete or engineered soils are first exposed to precipitation until the recycled concrete or soils are fully stabilized with the stormwater pH in the range of 6.5 to 8.5.

The benchmark value for pH is 8.5. Any time sampling indicates that pH is greater than 8.5, the high pH water must be prevented from entering the storm drainage system, surface waters, or groundwater, and, if necessary, the high pH water must be adjusted or neutralized. Refer to Section 5.1.12. BMP C1.59 High pH Neutralization Using CO₂. Also, refer to Sections 5.1.10 and 5.1.11 for additional concrete handling and washout area requirements.

Additional monitoring requirements may apply if the project is subject to the Ecology Construction Stormwater General Permit or other Ecology permits or authorizations. If the discharge is to a combined system, then the monitoring requirements must reflect the King County Construction Dewatering Authorization.

ATTACHMENT 1

Checklist to Select Small and Large Project Construction BMPs

ATTACHMENT 1 – CHECKLIST TO SELECT SMALL AND LARGE PROJECT CONSTRUCTION BMPs

Table 1a-1. Checklist to Select Small Project Construction BMPs.

Project Name:

Element Number	Required Element	Small Project ^a (check selection)	If not applicable, describe why in the space below.
1	Mark Clearing Limits and Environmentally Critical Areas	Recommended ^b BMPs: <input type="checkbox"/> E1.30 Preserving Natural Vegetation (refer to <i>Section 4.1.2.1</i>) <input type="checkbox"/> E1.35 Buffer Zones (refer to <i>Section 4.1.2.2</i>) <input type="checkbox"/> E1.50 High-Visibility Fencing (refer to <i>Section 4.1.2.5</i>)	
2	Retain Top Layer	Required BMP: Within the boundaries of the project site, retain the duff layer, topsoil, and native vegetation, if there is any, in an undisturbed state to the maximum extent possible. If it is not possible to retain the top layer in place, stockpile on site, cover to prevent erosion, and replace immediately upon completion of ground-disturbing activities to the maximum extent possible.	
3	Establish Construction Access	Required BMP: <input type="checkbox"/> E2.10 Stabilization Construction Access (refer to <i>Section 4.2.1.1</i>) Recommended BMPs: <input type="checkbox"/> E2.15 Tire Wash (refer to <i>Section 4.2.1.2</i>) <input type="checkbox"/> E2.20 Construction Road Stabilization (refer to <i>Section 4.2.1.3</i>)	
4	Protect Downstream Properties and Receiving Waters	Recommended BMP: <input type="checkbox"/> Ecology BMP C241 Temporary Sediment Pond (or Basin)	

Table 1a-2. Checklist to Select Small Project Construction BMPs.

Project Name:

Element Number	Required Element	Small Project ^a (check selection)	If not applicable, describe why in the space below.
5	Prevent Erosion and Sediment Transport from the Site	Required BMPs – one or more of the following: <input type="checkbox"/> E3.10 Filter Fence (refer to <i>Section 4.3.1</i>) <input type="checkbox"/> E3.20 Gravel Filter Berm (refer to <i>Section 4.3.2</i>) <input type="checkbox"/> E3.30 Vegetated Strip (refer to <i>Section 4.3.4</i>) <input type="checkbox"/> E3.35 Straw Wattles, Compost Socks, and Compost Berms (refer to <i>Section 4.3.5</i>) <input type="checkbox"/> E3.40 Sediment Trap (refer to <i>Section 4.3.6</i>) <input type="checkbox"/> E3.50 Portable Sediment Tank (refer to <i>Section 4.3.7</i>) <input type="checkbox"/> E3.60 Construction Stormwater Filtration (refer to <i>Section 4.3.8</i>) <input type="checkbox"/> Ecology BMP C231 Brush Barrier <input type="checkbox"/> Ecology BMP C241 Temporary Sediment Pond (or Basin) <input type="checkbox"/> Ecology BMP C250 Construction Stormwater Chemical Treatment	
6	Prevent Erosion and Sediment Transport from the Site by Vehicles	Required BMPs – one or more of the following: <input type="checkbox"/> E3.65 Cleaning Inlets and Catch Basins (refer to <i>Section 4.3.9</i>) <input type="checkbox"/> E3.70 Street Sweeping and Vacuuming (refer to <i>Section 4.3.10</i>)	
7	Stabilize Soils	Required BMPs for all exposed soils and stockpiles – one or more of the following: <input type="checkbox"/> E1.10 Temporary Seeding (refer to <i>Section 4.1.1.1</i>) <input type="checkbox"/> E1.15 Mulching, Matting, and Compost Blankets (refer to <i>Section 4.1.1.2</i>) <input type="checkbox"/> E1.20 Clear Plastic Covering (refer to <i>Section 4.1.1.3</i>) <input type="checkbox"/> E1.40 Permanent Seeding and Planting (refer to <i>Section 4.1.2.3</i>) <input type="checkbox"/> E1.45 Sodding (refer to <i>Section 4.1.2.4</i>) <input type="checkbox"/> E2.45 Dust Control (refer to <i>Section 4.2.1.6</i>) <input type="checkbox"/> Ecology BMP C126 Polyacrylamide for Soil Erosion Protection <input type="checkbox"/> Ecology BMP C130 Surface Roughening <input type="checkbox"/> Ecology BMP C131 Gradient Terracing	

Table 1a-3. Checklist to Select Small Project Construction BMPs.

Project Name:

Element Number	Required Element	Small Project ^a (check selection)	If not applicable, describe why in the space below.
8	Protect Slopes (refer to the Environmentally Critical Area ordinance [SMC 25.09.180] for additional requirements and development standards for steep slopes)	Required BMPs – one or more of the following: <input type="checkbox"/> Level Spreader (refer to <i>Appendix E</i>) <input type="checkbox"/> E2.35 Check Dams (refer to <i>Section 4.2.1.4</i>) <input type="checkbox"/> E2.40 Triangular Silt Dike (Geotextile-encased Check Dam) (refer to <i>Section 4.2.1.5</i>) <input type="checkbox"/> Pipe Slope Drains (refer to <i>Appendix E</i>) <input type="checkbox"/> E2.70 Subsurface Drains (refer to <i>Section 4.2.3.1</i>) <input type="checkbox"/> E2.80 Earth Dike and Drainage Swale (refer to <i>Section 4.2.3.2</i>) <input type="checkbox"/> Ecology BMP C201 Grass-lined Channels <input type="checkbox"/> Ecology BMP C130 Surface Roughening <input type="checkbox"/> Ecology BMP C131 Gradient Terracing	
9	Protect Storm Drains	Required BMPs: <input type="checkbox"/> E3.25 Inlet Protection (refer to <i>Section 4.3.3</i>) <input type="checkbox"/> E3.65 Cleaning Inlets and Catch Basins (refer to <i>Section 4.3.9</i>) <input type="checkbox"/> E3.70 Street Sweeping and Vacuuming (refer to <i>Section 4.3.10</i>)	
10	Stabilize Channels and Outlets	Recommended BMPs: <input type="checkbox"/> Level Spreader (refer to <i>Appendix E</i>) <input type="checkbox"/> E2.35 Check Dams (refer to <i>Section 4.2.1.4</i>) <input type="checkbox"/> E2.80 Earth Dike and Swale (refer to <i>Section 4.2.3.2</i>) <input type="checkbox"/> Outlet Protection (refer to <i>Appendix E</i>) <input type="checkbox"/> Ecology BMP C201 Grass-lined Channels <input type="checkbox"/> Ecology BMP C202 Channel Lining <input type="checkbox"/> Ecology BMP C203 Water Bars	

Table 1a-4. Checklist to Select Small Project Construction BMPs.

Project Name:

Element Number	Required Element	Small Project ^a (check selection)	If not applicable, describe why in the space below.
11	Control Pollutants (also refer to <i>Volume 4 — Source Control</i>)	Required BMPs: <input type="checkbox"/> C1.15 Material Delivery, Storage, and Containment (refer to <i>Section 5.1.1</i>) <input type="checkbox"/> C1.20 Use of Chemicals During Construction (refer to <i>Section 5.1.2</i>) <input type="checkbox"/> C1.25 Demolition of Buildings (refer to <i>Section 5.1.3</i>) <input type="checkbox"/> C1.30 Building Repair, Remodeling, and Construction (refer to <i>Section 5.1.4</i>) <input type="checkbox"/> C1.35 Sawcutting and Surfacing Pollution Prevention (refer to <i>Section 5.1.5</i>) <input type="checkbox"/> C1.45 Solid Waste Handling and Disposal (refer to <i>Section 5.1.6</i>) <input type="checkbox"/> C1.50 Disposal of Asbestos and Polychlorinated Biphenyls (PCBs) (refer to <i>Section 5.1.7</i>) <input type="checkbox"/> C1.55 Airborne Debris Curtain (refer to <i>Section 5.1.8</i>) <input type="checkbox"/> C1.56 Concrete Handling (refer to <i>Section 5.1.9</i>) <input type="checkbox"/> C1.58 Concrete Washout Area (refer to <i>Section 5.1.10</i>)	
12	Control Dewatering	Recommended BMP: <input type="checkbox"/> E4.20 Temporary Dewatering (refer to <i>Section 4.4.2</i>)	
13	Maintain BMPs	Required BMP: <input type="checkbox"/> Maintain and repair all temporary and permanent erosion and sediment control BMPs as needed to ensure continued performance of their intended function.	
14	Inspect BMPs	Required BMP: <input type="checkbox"/> Inspect, maintain, and repair all BMPs as needed to ensure continued performance of their intended function.	

Table 1a-5. Checklist to Select Small Project Construction BMPs.

Project Name:

Element Number	Required Element	Small Project ^a (check selection)	If not applicable, describe why in the space below.
15	Execute Construction Stormwater Control and Soil Management Plan	<p>Required BMPs:</p> <p>Implement and maintain an updated Construction Stormwater Control and Soil Management Plan, beginning with initial land disturbance.</p> <p><input type="checkbox"/> Retain the Small Project Construction Stormwater Control and Soil Management Plan on site or within reasonable access to the site. Modify the plan as needed.</p> <p>Coordination with Utilities, Contractors, and Others</p> <p><input type="checkbox"/> When preparing the Small Project Construction Stormwater Control and Soil Management Plan, the primary project proponent should evaluate, with input from utilities and other contractors, the stormwater management requirements for the entire project, including the utilities.</p> <p>Project Closeout:</p> <p><input type="checkbox"/> Remove all temporary erosion and sediment control BMPs within 5 business days after final site stabilization is achieved or after they are no longer needed—whichever is later.</p>	
16	Minimize Open Trenches	<p>Required BMP:</p> <p>In the construction of underground utility lines, where possible, no more than one hundred fifty (150) feet of trench should be opened at one time, unless soil is replaced within the same working day. Where consistent with safety and space considerations, place excavated material on the uphill side of trenches. Trench dewatering devices should discharge into a sediment trap or sediment pond.</p>	
17	Phase the Project	<p>Required BMPs:</p> <p>Construction Phasing</p> <p><input type="checkbox"/> Phase development projects where possible to prevent soil erosion and, to the maximum extent practical, the transport of sediment from the site during construction.</p> <p>Seasonal Work Limitations</p> <p><input type="checkbox"/> From October 31 through April 1, clearing, grading, and other soil-disturbing activities will be subject to additional limitations.</p>	

Table 1a-6. Checklist to Select Small Project Construction BMPs.

Project Name:

Element Number	Required Element	Small Project ^a (check selection)	If not applicable, describe why in the space below.
18	Install Permanent Flow Control and Water Quality Facilities	<ul style="list-style-type: none"> ● Refer to <i>Volume 1</i> for applicable minimum requirements and <i>Volume 3</i> for BMP design. 	
19	Protect Stormwater BMPs	<p>General: Protect all stormwater BMPs from sedimentation through installation and maintenance of erosion and sediment control BMPs. Restore the BMPs to their fully functioning condition if they accumulate sediment during construction. Restoring the stormwater BMP must include removal of sediment and any sediment-laden soils and replacing the removed soils with soils meeting the design specification.</p> <p><input type="checkbox"/> The approved plan sheets provide construction sequencing that protects the infiltration facility during construction.</p> <p>Sediment Control: Protect infiltration BMPs from sedimentation that can clog the facility and reduce infiltration capacity.</p> <p><input type="checkbox"/> Minimize site disturbance at the location of the infiltration BMPs and in up-gradient areas.</p> <p><input type="checkbox"/> Do not use infiltration BMPs as sediment control facilities.</p> <p><input type="checkbox"/> Direct all drainage away from the facility location after initial rough grading.</p> <p><input type="checkbox"/> Flow can be directed away from the facility with temporary diversion swales or other approved protection.</p> <p><input type="checkbox"/> Do not construct infiltration BMPs until all contributing drainage areas are stabilized with appropriate erosion and sediment control BMPs and to the satisfaction of the engineer.</p>	

Table 1a-7. Checklist to Select Small Project Construction BMPs.

Project Name:

Element Number	Required Element	Small Project ^a (check selection)	If not applicable, describe why in the space below.
19	Protect Stormwater BMPs (continued)	<input type="checkbox"/> Do not construct infiltration BMPs until all contributing drainage areas are stabilized with appropriate erosion and sediment control BMPs and to the satisfaction of the engineer. <input type="checkbox"/> Inspect and maintain erosion and sediment control practices on a regular basis. If deposition of sediment occurs in the infiltration area, remove material and scarify the surface to a minimum depth of 3 inches. <input type="checkbox"/> Control erosion and avoid introducing sediment from surrounding land uses onto permeable pavements. Do not allow muddy construction equipment on the base material or pavement. Do not allow sediment-laden runoff onto permeable pavements or base materials. <input type="checkbox"/> Permeable pavement fouled with sediments or no longer passing an initial infiltration test must be cleaned until infiltrating per design or replaced. Compaction Prevention: Soil compaction can lead to a reduction of infiltration rates and facility failure; accordingly, minimizing compaction of the base and sidewalls of the infiltration area is critical. <input type="checkbox"/> Before the development site is graded, rope or fence the area of the infiltration BMP to restrict access and flag to prevent soil compaction by heavy equipment and foot traffic. <input type="checkbox"/> Perform excavation with machinery operating adjacent to the infiltration BMP and do not allow heavy equipment with narrow tracks, narrow tires, or large lugged, high-pressure tires on the bottom of the infiltration BMP footprint. <input type="checkbox"/> Protect established completed lawn and landscaped areas from compaction due to construction equipment. <input type="checkbox"/> Do not excavate during wet or saturated conditions.	

^a A small project is defined as one with less than 5,000 square feet of new plus replaced hard surface and less than 10,000 square feet of land-disturbing activity.

^b Recommended BMPs provide further guidance for minimizing potential stormwater pollution resulting from activities.

Construction Stormwater Pollution Prevention Plan Checklist

Project Number:
Review Date:
Onsite Inspection Review Date:
Construction SWPPP Reviewer:

Table 1b-1. Checklist to Select Large Project Construction BMPs.

Project Name:

Element Number	Required Element	Large Project ^a (check selection)	If not applicable, describe why in the space below.
1	Mark Clearing Limits and Environmentally Critical Areas	Required BMPs: <input type="checkbox"/> E1.30 Preserving Natural Vegetation (refer to <i>Section 4.1.2.1</i>) <input type="checkbox"/> E1.35 Buffer Zones (refer to <i>Section 4.1.2.2</i>) <input type="checkbox"/> E1.50 High-Visibility Fencing (required at the edges of non-disturbance areas of environmentally critical areas (ECAs) and their buffers; refer to <i>Section 4.1.2.5</i>)	
2	Retain Top Layer	Required BMP: Within the boundaries of the project site, retain the duff layer, topsoil, and native vegetation, if there is any, in an undisturbed state to the maximum extent feasible. If it is not feasible to retain the top layer in place, stockpile on site, cover to prevent erosion, and replace immediately upon completion of the ground-disturbing activities to the maximum extent possible.	
3	Establish Construction Access	Required BMPs: <input type="checkbox"/> E2.10 Stabilized Construction Access (refer to <i>Section 4.2.1.1</i>) <input type="checkbox"/> E2.15 Tire Wash (refer to <i>Section 4.2.1.2</i>) <input type="checkbox"/> E2.20 Construction Road Stabilization (refer to <i>Section 4.2.1.3</i>)	
4	Protect Downstream Properties and Receiving Waters	Required BMP for contributing area of 3 acres or greater: <input type="checkbox"/> Ecology BMP C241 Sediment Pond (Temporary)	

Table 1b-2. Checklist to Select Large Project Construction BMPs.

Project Name:

Element Number	Required Element	Large Project ^a (check selection)	If not applicable, describe why in the space below.
5	Prevent Erosion and Sediment Transport from the Site	Required BMPs: <input type="checkbox"/> E3.10 Filter Fence (refer to <i>Section 4.3.1</i>) <input type="checkbox"/> Ecology BMP C231 Brush Barrier <input type="checkbox"/> E3.20 Gravel Filter Berm (refer to <i>Section 4.3.2</i>) AND <input type="checkbox"/> E3.40 Sediment Trap (refer to <i>Section 4.3.6</i>) OR <input type="checkbox"/> Ecology BMP C241 Sediment Pond (Temporary) OR <input type="checkbox"/> E3.50 Portable Sediment Tank (refer to <i>Section 4.3.7</i>) Additional recommended BMPs: <input type="checkbox"/> E3.30 Vegetated Strip (refer to <i>Section 4.3.4</i>) <input type="checkbox"/> E3.35 Straw Wattles, Compost Socks, and Compost Berms (refer to <i>Section 4.3.5</i>) <input type="checkbox"/> E3.60 Construction Stormwater Filtration (refer to <i>Section 4.3.8</i>) <input type="checkbox"/> Ecology BMP C250 Construction Stormwater Chemical Treatment	
6	Prevent Erosion and Sediment Transport from the Site by Vehicles	Required BMPs: <input type="checkbox"/> E3.65 Cleaning Inlets and Catch Basins (refer to <i>Section 4.3.9</i>) <input type="checkbox"/> E3.70 Street Sweeping and Vacuuming (refer to <i>Section 4.3.10</i>)	

Table 1b-3. Checklist to Select Large Project Construction BMPs.

Project Name:

Element Number	Required Element	Large Project ^a (check selection)	If not applicable, describe why in the space below.
7	Stabilize Soils	Required BMPs for all exposed soils and stockpiles – one or more of the following: <input type="checkbox"/> E1.10 Temporary Seeding (refer to <i>Section 4.1.1.1</i>) <input type="checkbox"/> E1.15 Mulching, Matting, and Compost Blankets (refer to <i>Section 4.1.1.2</i>) <input type="checkbox"/> E1.20 Clear Plastic Covering (refer to <i>Section 4.1.1.3</i>) <input type="checkbox"/> E1.40 Permanent Seeding and Planting (refer to <i>Section 4.1.2.3</i>) <input type="checkbox"/> E1.45 Sodding (refer to <i>Section 4.1.2.4</i>) <input type="checkbox"/> E2.45 Dust Control (refer to <i>Section 4.2.1.6</i>) <input type="checkbox"/> Ecology BMP C130 Surface Roughening <input type="checkbox"/> Ecology BMP C131 Gradient Terracing <input type="checkbox"/> Ecology BMP C126 Polyacrylamide for Soil Erosion Protection	
8	Protect Slopes (refer to the Environmentally Critical Areas ordinance [SMC 25.09.180] for additional requirements and development standards for steep slopes)	Required BMPs – one or more of the following: <input type="checkbox"/> Level Spreader (refer to <i>Appendix E</i>) <input type="checkbox"/> E2.35 Check Dams (refer to <i>Section 4.2.1.4</i>) <input type="checkbox"/> E2.40 Triangular Silt Dike (Geotextile-encased Check Dam) (refer to <i>Section 4.2.1.5</i>) <input type="checkbox"/> Pipe Slope Drains (refer to <i>Appendix E</i>) <input type="checkbox"/> E2.70 Subsurface Drains (refer to <i>Section 4.2.2.2</i>) <input type="checkbox"/> E2.80 Earth Dike and Drainage Swale (refer to <i>Section 4.2.3.2</i>) <input type="checkbox"/> Ecology BMP C130 Surface Roughening <input type="checkbox"/> Ecology BMP C131 Gradient Terracing <input type="checkbox"/> Ecology BMP C201 Grass-lined Channels	

Table 1b-4. Checklist to Select Large Project Construction BMPs.

Project Name:

Element Number	Required Element	Large Project ^a (check selection)	If not applicable, describe why in the space below.
9	Protect Storm Drains	Required BMPs: <input type="checkbox"/> E3.25 Inlet Protection (refer to <i>Section 4.3.3</i>) <input type="checkbox"/> E3.65 Cleaning Inlets and Catch Basins (refer to <i>Section 4.3.9</i>) <input type="checkbox"/> E3.70 Street Sweeping and Vacuuming (refer to <i>Section 4.3.10</i>)	
10	Stabilize Channels and Outlets	Required BMPs – one or more of the following: <input type="checkbox"/> Level Spreader (refer to <i>Appendix E</i>) <input type="checkbox"/> E2.35 Check Dams (refer to <i>Section 4.2.1.4</i>) <input type="checkbox"/> E2.80 Earth Dike and Drainage Swale (refer to <i>Section 4.2.3.2</i>) <input type="checkbox"/> Outlet Protection (refer to <i>Appendix E</i>) <input type="checkbox"/> Ecology BMP C201 Grass-lined Channels <input type="checkbox"/> Ecology BMP C202 Riprap Channel Lining <input type="checkbox"/> Ecology BMP C203 Water Bars	
11	Control Pollutants (also refer to <i>Volume 4 — Source Control</i>)	Required BMPs: <input type="checkbox"/> C1.15 Material Delivery, Storage, and Containment (refer to <i>Section 5.1.1</i>) <input type="checkbox"/> C1.20 Use of Chemicals During Construction (refer to <i>Section 5.1.2</i>) <input type="checkbox"/> C1.25 Demolition of Buildings (refer to <i>Section 5.1.3</i>) <input type="checkbox"/> C1.30 Building Repair, Remodeling, and Construction (refer to <i>Section 5.1.4</i>) <input type="checkbox"/> C1.35 Sawcutting and Surfacing Pollution Prevention (refer to <i>Section 5.1.5</i>) <input type="checkbox"/> C1.45 Solid Waste Handling and Disposal (refer to <i>Section 5.1.6</i>) <input type="checkbox"/> C1.50 Disposal of Asbestos and Polychlorinated Biphenyls (PCBs) (refer to <i>Section 5.1.7</i>) <input type="checkbox"/> C1.55 Airborne Debris Curtain (refer to <i>Section 5.1.8</i>) <input type="checkbox"/> C1.56 Concrete Handling (refer to <i>Section 5.1.9</i>) <input type="checkbox"/> C1.58 Concrete Washout Area (refer to <i>Section 5.1.10</i>) <input type="checkbox"/> C1.59 High pH Neutralization Using CO ₂ (refer to <i>Section 5.1.11</i>)	

Table 1b-5. Checklist to Select Large Project Construction BMPs.

Project Name:

Element Number	Required Element	Large Project ^a (check selection)	If not applicable, describe why in the space below.
12	Control Dewatering	Required BMP: <input type="checkbox"/> E4.20 Temporary Dewatering (refer to <i>Section 4.4.2</i>)	
13	Maintain BMPs	Required BMP: <input type="checkbox"/> Maintain and repair all temporary and permanent erosion and sediment control BMPs as needed to ensure continued performance of their intended function.	
14	Inspect BMPs	Required BMP: <input type="checkbox"/> Inspect, maintain, and repair all BMPs as needed to ensure continued performance of their intended function. <input type="checkbox"/> Certified Erosion and Sediment Control Lead (refer to <i>Section 2.3</i>): For projects over 1 acre; inspections should be conducted by the Certified Erosion and Sediment Control Lead identified in the Large Project Construction Stormwater Control and Soil Management Plan.	
15	Execute Construction Stormwater Control and Soil Management Plan	Required BMPs: Implement and maintain an updated Construction Stormwater Control and Soil Management Plan beginning with initial land disturbance. <input type="checkbox"/> Retain the Large Project Construction Stormwater Control and Soil Management Plan on site or within reasonable access to the site. Modify the plan as needed. Coordination with Utilities, Contractors, and Others <input type="checkbox"/> The primary project proponent should evaluate, with input from utilities and other contractors, the stormwater management requirements for the entire project, including the utilities, when preparing the Small Project Construction Stormwater Control and Soil Management Plan. Project Closeout <input type="checkbox"/> Remove all temporary erosion and sediment control BMPs within 5 business days after final site stabilization is achieved or after they are no longer needed, whichever is later.	

Table 1b-6. Checklist to Select Large Project Construction BMPs.

Project Name:

Element Number	Required Element	Large Project ^a (check selection)	If not applicable, describe why in the space below.
16	Minimize Open Trenches	Required BMP: In the construction of underground utility lines, where possible, no more than one hundred and fifty (150) feet of trench should be opened at one time unless soil is replaced within the same working day. Where consistent with safety and space considerations, place excavated material on the uphill side of trenches. Trench dewatering devices should discharge into a sediment trap or sediment pond.	
17	Phase the Project	Required BMPs: Construction Phasing <input type="checkbox"/> Phase development projects where possible to prevent soil erosion and, to the maximum extent practical, the transport of sediment from the site during construction. Seasonal Work Limitations <input type="checkbox"/> From October 31 through April 1, clearing, grading, and other soil-disturbing activities will be subject to additional limitations.	
18	Install Permanent Flow Control and Water Quality Facilities	Refer to <i>Volume 1</i> for applicable minimum requirements and <i>Volume 3</i> for BMP design.	
19	Protect Stormwater BMPs	General: Protect all stormwater BMPs from sedimentation through installation and maintenance of erosion and sediment control BMPs. Restore the BMPs to their fully functioning condition if they accumulate sediment during construction. Restoring the stormwater BMP must include removal of sediment and any sediment-laden soils and replacing the removed soils with soils meeting the design specification. <input type="checkbox"/> The approved plan sheets provide construction sequencing that protects the infiltration facility during construction. Sediment Control: Protect infiltration BMPs from sedimentation that can clog the facility and reduce infiltration capacity. <input type="checkbox"/> Minimize site disturbance at the location of the infiltration BMPs and in up-gradient areas. <input type="checkbox"/> Do not use infiltration BMPs as sediment control facilities. <input type="checkbox"/> Direct all drainage away from the facility location after initial rough grading.	

Table 1b-7. Checklist to Select Large Project Construction BMPs.

Project Name:

Element Number	Required Element	Large Project ^a (check selection)	If not applicable, describe why in the space below.
19	Protect Stormwater BMPs (continued)	<ul style="list-style-type: none"> <input type="checkbox"/> Flow can be directed away from the facility with temporary diversion swales or other approved protection. <input type="checkbox"/> Do not construct infiltration BMPs until all contributing drainage areas are stabilized with appropriate erosion and sediment control BMPs and to the satisfaction of the engineer. <input type="checkbox"/> Inspect and maintain erosion and sediment control practices on a regular basis. If deposition of sediment occurs in the infiltration area, remove material and scarify the surface to a minimum depth of 3 inches. <input type="checkbox"/> Control erosion and avoid introducing sediment from surrounding land uses onto permeable pavements. Do not allow muddy construction equipment on the base material or pavement. Do not allow sediment-laden runoff onto permeable pavements or base materials. <input type="checkbox"/> Permeable pavement clogged with sediments or no longer passing an initial infiltration test must be cleaned until infiltrating per design or replaced. <p>Compaction Prevention: Soil compaction can lead to a reduction of infiltration rates and facility failure; accordingly, minimizing compaction of the base and sidewalls of the infiltration area is critical.</p> <ul style="list-style-type: none"> <input type="checkbox"/> Before the development site is graded, rope or fence the area of the infiltration BMP to restrict access and flag to prevent soil compaction by heavy equipment and foot traffic. <input type="checkbox"/> Perform excavation with machinery operating adjacent to the infiltration BMP and do not allow heavy equipment with narrow tracks, narrow tires, or large lugged, high-pressure tires on the bottom of the infiltration BMP footprint. <input type="checkbox"/> Protect established completed lawn and landscaped areas from compaction due to construction equipment. <input type="checkbox"/> Do not excavate during wet or saturated conditions. 	

^a A large project is one with greater than or equal to 5,000 square feet of new plus replaced hard surface or greater than or equal to 10,000 square feet of land-disturbing activity.

^b Recommended BMPs provide further guidance foaar minimizing potential stormwater pollution resulting from activities.

Construction Stormwater Pollution Prevention Plan Checklist

Project Number:
Review Date:
Onsite Inspection Review Date:
Construction SWPPP Reviewer: