

SAND POINT NAVAL AIR STATION LANDMARK DISTRICT DESIGN GUIDELINES

TABLE OF CONTENTS

District Overview	2
<i>Architectural Character</i>	
<i>Landscape Features</i>	
Sand Point NAS Landmark District Map	4
List of Contributing Historic Resources	5
List of Non-Contributing Historic Resources & Other Properties	6
Purpose & Intent of Design Guidelines	6
<i>Preservation Policy & Procedures</i>	
<i>Exempt Activities (no Certificate of Approval required)</i>	
<i>Administrative Review</i>	
<i>Preservation for Future Use</i>	
General Standards & Guidelines	12
District Specific Design Guidelines	13
<i>Buildings & Structures</i>	13
<i>Building Sites & District Setting</i>	20
Appendix A <i>The Secretary of the Interior's Standards for Rehabilitation & Preservation Terminology</i>	
Appendix B <i>Paint Color Palette</i>	
Appendix C <i>Annotated Historic Plant List</i>	
Appendix D <i>Signage & Wayfinding Plan</i>	

DISTRICT OVERVIEW

Sand Point Naval Air Station Landmark District is located in northeast Seattle on the Sand Point peninsula within Warren G. Magnuson Park. The 89.5-acre historic district encompasses three discontinuous parts of the original Naval Air Station Seattle site and contains concentrations of intact historic resources directly associated with the Naval Air Station operations between 1926 and 1953. The district is characterized by strong institutional cohesion of substantial buildings and structures linked organizationally through an intact historic road system. The streetscapes and landscape features contribute significantly to the unity of the setting and character of the historic district. During the period of Navy use from the post-World War II era to 1991 many outlying parcels were decommissioned and converted to local uses. Also during this period many structures were demolished; these included peripheral and smaller buildings. However, the historic district retains and exhibits a high level of physical integrity. Intact buildings, structures, and objects continue to convey the quality and purpose of design, material, scale, workmanship; and, distinct functional building types reflect the pre-, during, and post-World War II operations of the Naval Air Station and its administrative role in the operation of other naval aviation facilities within the Thirteenth Naval District. The boundaries of the main core of the district generally follow existing and former roadways. The district encompasses a total of 54 contributing and non-contributing historic resources.

Architectural Character

The landmark district includes notable examples of Art Deco, Art Moderne and Colonial Revival style buildings as well as utilitarian buildings and structures that are good examples of industrial vernacular and military architecture. The district also retains an important collection of Public Works Administration and Works Progress Administration funded projects that date from the pre-WWII era of station expansion. The buildings and structures within the landmark district remain generally intact and exhibit moderate to high levels of physical integrity. The organizational relationships among buildings remain evident, with maintenance and operational facilities situated to the north; residences and recreation facilities to the south; offices, training, and administration facilities centrally located to transition between these; and munitions and other aviation related facilities situated a distance away to the east, in close proximity to the operation of aircraft to be serviced. Primary building and structure types include aircraft hangars, office and administration buildings, steam plant, officer housing and barracks, munitions magazines and storehouses, and aircraft maintenance shops. The use of brick, concrete and steel as structural, and as cladding elements, is a dominant design element throughout the district. The scale and massing of facilities, in particular the hangars, reflect the magnitude of the aircraft that constituted the primary operational mission of the air station. *(For specific architectural descriptions and identification of character defining features and finishes of individual buildings and structures, please refer to the individual Historic Resource descriptions and photographs included in Appendix B of the Landmark Nomination Report.)*

Landscape Features

The landscape is a contributing design feature of the landmark district. The scale of streetscapes, placement, and selection of trees and shrubs, coupled with the use of lawns and open space, reinforce its formal setting and noble purpose of national defense as the nation braced for WWII. Only a small amount of the pre-naval historic landscape of Sand Point peninsula remains today. Mud Lake, a 20-acre lake/bog that was located east of the former Married Officer's Quarters was infilled. The Pontiac Bay area to the north had rolling, forested wetlands fed by a small stream flowing into Lake Washington prior to the settlement and conversion to farmlands.

As the Naval Station was developed, the forest, wetlands and knolls were leveled to create open, relatively level expanses of aircraft runways and naval facilities. The original street trees were planted within the Naval Station in the late 1930s and many of these remain along Sand Point Way NE and 62nd Avenue NE. These trees are a prominent feature of the southern half of the district. Other original ornamental trees also remain scattered throughout the district setting.

Three trees within the district are of particular importance to the history of the site and have been formally identified as historic landscape features to be preserved and maintained.

- A white spruce is located off the southeast corner of Building 25. It was reportedly planted in 1931 by the Alaskan Yukon Pioneers' Society as a commemorative planting.
- A large Atlas Cedar (*Cedrus atlantica*), commonly referred to as the Freedom Tree or Memorial Tree is located near the southeast corner of Building 25. When the Freedom Tree was approximately forty years old, it was re-dedicated as part of the Vietnam Memorial erected in 1972.
- A large Atlas Cedar is located at the southern end of 62nd Avenue NE, to the southeast of Building 26 South. This tree serves as a counterpoint to the flagpole located at the north end of 62nd Avenue NE, directly in front of Building 25. It was designated as the "holiday tree" when the base was operational.

In addition to the identified trees, lawn areas and open space are important features within the vicinity of the historic office, recreation, and residential buildings. Other landscape features that evoke the character of the original planting designs include the planting areas, which accent the main entry (NE 74th Street) approach from Sand Point Way NE, and the residual remnants from a brick-lined rose garden indicated on historic plans, that are located to the south of Building 26 South.

List of Contributing Historic Resources (by Historic Name/Number)

Historic Name/Number	Historic Use/Name	Resource Type	Built/ Additions	Site ID No.¹
Pier No. 1	shipping pier	structure	1928-1937	30
Ramp No. 1	seaplane ramp	structure	1928	52
Building 2	Assembly & Repair Shop	building	1929, 1939-44	19
Building 5 (A-D)	Storehouse	building	1929, 1938 1940, 1943	51
Building 9	Barracks	building	1929, 1930 1939, 1944	41
Building 11	Public Works shop & office	building	1938, 1939-1944	21
Building 12	Boiler Plant	building	1930, 1942	16
Building 18	Firehouse & garage	building	1936, 1945-52	10
Structure 19	Magazine (munitions storage)	structure	1936	5
Building 20	Torpedo Shop	building	1937	22
Building 25	Administration Building	building	1937, 1938-1944	49
Building 26 N	Bachelor Officers' Qtrs	building	1939-1943	31
Building 26 S	Bachelor Officers' Qtrs	building	1939-1943	32
Building 27	Seaplane hangar	building	1937	53
Building 29	Dispensary/hospital	building	1937, 1938-1944	50
Building 30	Naval Reserve Hangar/offices	building	1939	13
Building 31	Boathouse	building	1938	29
Building 32	hangar	building	1939	1
Building 33	hangar	building	1939	2
Building 40	paint storage	building	1940	23
Building 41	Ships Service Gas Station	building	1939	12
Building 42	Main Electric Substation	building	1939	45
Building 47	Recreation Building	building	1941	11
Structure 54	magazine (munitions storage)	structure	1941	8
Structure 55	magazine (munitions storage)	structure	1941	9
Structure 69	Bachelor Officer Qtrs carport	structure	1939-1943	35
Building 98	Gas Pump House	building	1940	24
Building 115	tank repair & storage	building	1944	26
Building 116	Sewage Pump House	building	1939-1943	28
Building 119	dope storage	building	1939-43	17
Structure 126	Beach Shelter	structure	1936	6
Building 138	Gatehouse	building	1942	14
Building 224	Junior Officers' Qtrs	building	1944	34
Building 275	Shelter/storage	building	1945	27
Building 312	Arms Magazine	building	1952	7
Building 330	Married Officers' Qtrs "A"	building	1939	38
Building 331	Married Officers' Qtrs "B"	building	1939	37
Building 332	Married Officers' Qtrs "C"	building	1939	36
	Loading Dock (west of Bldg 9)	structure	1939-1943	40
Object 369	Round the World Monument	object	1924	42
Object 360	flagpole	object	1939-1944	43
Vietnam Memorial		object	1972	44

¹ Site ID No. is the inventory reference key to the individual Historic Resource descriptions and photographs included in Appendix B of the Landmark Nomination Report. (Refer to Appendix B for specific architectural descriptions and identification of character defining features and finishes of individual buildings and structures.)

List of Non-Contributing Historic Resources & Other Properties (by Name/Use)

Historic/Common Name or Number	Historic Use	Resource Type	Site ID No.
<i>Building 67 (Mountaineers)</i>	<i>Motor Pool garage</i>	<i>building</i>	15
<i>Building 141</i>	<i>Respiratory Training</i>	<i>building</i>	46
<i>Building 192</i>	<i>Low Pressure Training</i>	<i>building</i>	47
<i>Building 299</i>	<i>Inflammable storage</i>	<i>building</i>	18
<i>Building 407</i>	<i>Hazardous waste storage</i>	<i>building</i>	20
<i>Building 38 (NOAA Guardhouse)</i>	<i>Sentry House</i>	<i>building</i>	3
<i>NOAA Overpass</i>	<i>overpass</i>	<i>structure</i>	4
<i>Structure 1010</i>	<i>Gas Barrel Rack</i>	<i>structure</i>	25
<i>Motorcycle Storage</i>	<i>storage shed</i>	<i>building</i>	33
<i>Structure 337</i>	<i>pedestrian bridge</i>	<i>structure</i>	39
<i>Building 403</i>	<i>Generator Building</i>	<i>building</i>	48
<i>Brettler Family Place Apartment Buildings</i>		<i>Building(s)</i>	
<i>Lowry Family Community Building</i>		<i>building</i>	

PURPOSE & INTENT OF DESIGN GUIDELINES

The purpose and intent of these design guidelines is to provide specific guidance regarding the rehabilitation and preservation of the historic resources and the setting of Sand Point Naval Air Station (NAS) Landmark District. The district was determined eligible for listing in the National Register of Historic Places as part of the transfer of the property from the U.S. Navy to the City of Seattle. At the time of the transfer in October 1997, a Memorandum of Agreement was signed that specified various preservation requirements including the preparation of the *Sand Point Historic Properties Reuse and Protection Plan*, which was completed in 1998. The district was formally listed in the National Register of Historic Places in 2010 and was designated a local landmark district by the City of Seattle Landmarks Preservation Board in March 2011 per SMC 25.12. The Sand Point NAS Landmark District design guidelines are intended to:

- Fulfill the preservation goals as established by the *Sand Point Historic Properties Reuse and Protection Plan*
- Adhere to *The Secretary of the Interior's Standards for Rehabilitation* (and associated National Park Service guidelines & technical briefs)
- Provide user-friendly guidance for building owners, tenants and project proponents
- Facilitate formal design review of all projects subject to City of Seattle Landmarks Preservation Board review and approval
- Provide guidance for LPB staff for the review of alterations not subject to LPB review and approval but subject to staff review and approval.
- Facilitate review for all projects subject to the Washington State Department of Archaeology & Historic preservation (DAHP) review pursuant to the 1997 Memorandum of Agreement and Section 106 Review

Preservation Policy & Procedures

Jurisdiction over changes and improvements to buildings and other elements in this City of Seattle landmark district is vested in the Seattle Landmarks Preservation Board (LPB) per SMC 25.12. Protection of properties located within this landmark district and identified as features to be preserved in the Report on Designation [LPB 129/11] is a function of the LPB design review process. This local level of jurisdiction includes all proposed modifications that may affect the district site and the exteriors of all buildings, structures and objects within the district boundaries with the exception of those properties exempted in the Report on Designation. A Certificate of Approval (COA) must be obtained prior to making any alterations to a contributing property or the district setting pursuant to the Controls and Incentives approved by the LPB on July 3, 2013. Submission and review of Certificate of Approval applications is undertaken according to rules and procedures adopted by the Landmarks Preservation Board in accordance with the SMC 25.12 and the Administrative Code of the City of Seattle. The Seattle Landmarks Preservation Board has formally adopted *The Secretary of the Interior's Standards for Rehabilitation* (and associated rehabilitation guidelines). Entirely exempt activities or construction work that may be subject to LPB staff review is noted below.

These guidelines shall become effective upon filing with the City Clerk. The LPB may, at a public hearing and in accordance with the District ordinance (SMC 25.21), add to, subtract from, or amend these Design Guidelines as adopted on July 3, 2013.

Exempt Activities

A Certificate of Approval is not required for the following:

- a. Any in-kind maintenance or repairs of the features listed in Section A.1.
- b. Installation, removal and/or addition of the following landscape elements: trees eight inches or under in diameter measured four and one half feet above ground; shrubs, perennials, and annuals.
- c. Removal of non-native plants of any size.
- d. Removal of trees of any size identified as a hazard by a certified arborist.
- e. Installation, removal, or alterations of temporary site furnishings, including benches, chairs, tables, and trash receptacles not permanently attached to designated buildings/structures or landscape features.
- f. Removal or alterations to the following buildings/structures:
 1. NOAA Guardhouse;
 2. NOAA Overpass;
 3. Building 67 Mountaineers Headquarters, Historic name: Motor Pool Garage;
 4. Building 299, Historic name : Inflammable Stores Building;
 5. Building 407, Historic name: Hazardous Waste Storage;

6. Structure S-101 located adjacent to Building 115, Historic name: Tank Truck Loading Rack;
 7. Structure 337, Overhead Walkway;
 8. Building 141, Historic name: Respiratory Training Building;
 9. Building 192, Historic name: Low-Pressure Training Building;
 10. Building 403, Historic name: Generator Building;
 11. Building 42, Historic name: Main Substation;
 12. Brettler Family Place Apartments Buildings;
 13. Lowry Family Community Building; and,
 14. Tennis Center Sand Point.
- g. In-kind street, sidewalk or curb replacement on SDOT streets and/or rights-of-way, or parking area resurfacing.
 - h. Installation or removal of identification/name signs, wayfinding signage which follows design concepts in the Sand Point / Magnuson Park Wayfinding and Signage Master Plan, and ADA signage.
 - i. Installation or removal of drinking fountains, umbrellas, vendor carts, tents for temporary events, bicycle racks, and bike storage shelters, that are not permanently affixed to buildings or structures, or landscape and features identified in the Sand Point Naval Air Station Landmark District Design Guidelines.
 - j. Paint colors as defined in the Sand Point Naval Air Station Landmark District Design Guidelines.
 - k. Removal and replacement of non-original light fixtures.
 - l. Installation, removal or replacement of recreational structures including but not limited to playground equipment and rock climbing areas.
 - m. Installation or removal of any temporary structures associated with special events held by on-site organizations or by organizations including those issued a Special Event Permit issued by Seattle Parks and Recreation.
 - n. All work that is temporary in nature that does not damage character defining features; this includes art installations, event signage, and temporary signage as defined in SMC 23.55.012.
 - o. Alterations or removal of Navy-era utility infrastructure (in-ground or above grade) elements, such as electric substation structures, electric or steam system vaults, gasoline system valve vaults or enclosures, concrete encased conduit or piping – below or above ground.

Except, when any of the above structures are demolished or altered (which does not require a Certificate of Approval) that any site improvements will require review and approval pursuant to SMC 25.12 and the adopted guidelines with the exception of those items identified under Administrative Review.

Administrative Review

Administrative review and approval is available for the items listed below according to the following procedures. The Owner shall submit to the City Historic Preservation Officer (CHPO) a written request for these alterations, including applicable drawings and/or specifications. If the CHPO, upon examination of submitted plans and specifications, determines that such alterations are consistent with the purposes of SMC 25.12 the alterations shall be approved without the need for any further action by the Board. If the CHPO disapproves such alterations, the Owner may submit revised materials to the CHPO, or submit in accordance with the Certificate of Approval process set forth in SMC 25.12.

The CHPO shall transmit his or her written decision on the Owner's submittal to the Owner. Failure of the CHPO to approve or disapprove the request within fourteen (14) business days shall constitute approval of the request.

Administrative review is available for the following:

- a. For the specified features and characteristics of the exterior of the building, the addition or elimination of duct conduits, HVAC vents, grilles, fire escapes, pipes, and other similar wiring or mechanical elements necessary for the normal operation of the building; and changes that encourage energy efficiency and renewable energy efforts including but not limited to solar panels and sky lights.
- b. Site/landscape grading which does not directly affect designated landscape features, those specifically contributing to the district.
- c. Removal or addition of sidewalks, curbs, pathways and/or crosswalks on non-SDOT streets and/or rights-of-way, Parks roads, private roads or driveways and utility easements. Additions designed per SMC 23.72.010 (Sand Point Overlay District Development Standards).
- d. Installation or removal of on-premises signs as described in per SMC 23.55.032 (Signs in the Sand Point Overlay District)

- e. Installation or removal of off-premises signs as described in SMC 23.55.032 F (Signs in the Sand Point Overlay District) and the Warren G. Magnuson Park Wayfinding and Signage Master Plan.
- f. Installation of new light poles, pedestrian light poles which are similar to those installed in the 1999-2000 utility upgrade project.
- g. Installation of traffic control structures, signage, or similar elements both in the public right-of-way and on private roads.
- h. Installation or removal of safety and security lighting, cameras, and security system equipment.
- i. Paint colors that are not defined in the Sand Point Naval Air Station Landmark District Design Guidelines.
- j. Installation of community garden(s).
- k. Installation, alteration or removal of boundary fencing and gates.
- l. Installation, alteration or removal of fencing for storage areas or utility or mechanical equipment screening, when consisting of chain link, uncoated or black vinyl coated.
- m. Replacement of existing awnings, if not in-kind.
- n. Installation or removal of Public Art (1% for Arts)
- o. Installation or removal of exterior storage containers when located on paved areas.
- p. Mothballing of buildings in the Landmark District.
- q. Installation or removal of seasonal food and beverage concession structures/trailers when located on paved areas.
- r. ADA improvements.

Preservation for Future Use

If it has been demonstrated that it is not feasible to put a contributing property within the district into a productive use then consideration should be given to closing up the building to protect it from weather and vandalism. This strategy, commonly known as mothballing (as described above under ***Administrative Review***), is a viable and preferred alternative to demolition and a necessary and effective means of protecting the building while further planning or fundraising for a feasible rehabilitation project is undertaken. The three highest priorities for such an approach are 1) to protect the building from vandalism or sudden loss, 2) to weatherize and maintain the property in order to stop moisture penetration, and 3) to control the humidity levels inside once the building has been secured. All such work that will affect the exterior of a contributing resource should be guided by *Preservation Brief 31: Mothballing Historic Buildings* [Technical Preservation Services, National Park Service, Department of the Interior].

GENERAL STANDARDS & GUIDELINES

The Secretary of the Interior's Standards for Rehabilitation (and associated rehabilitation guidelines) are the basic guiding principles upon which the Sand Point NAS Landmark District design guidelines are based.² *Rehabilitation is defined as the act or process of making possible a compatible use for a property through repair, alterations, and additions while preserving those portions or features which convey its historical, cultural, or architectural values.*³

The following general guidance further clarifies the “Rehabilitation” approach and should be applied to all rehabilitation projects within the district:

Protect and Maintain Historic Materials and Features Wherever feasible, every effort should be made to identify, protect and maintain intact original and/or historic building materials, architectural features and design details. All cladding materials and features should only be cleaned when necessary using the gentlest methods possible and no abrasive methods of cleaning.

Repair Historic Materials and Features When the physical condition of character-defining materials or features requires work the preferred approach is to repair or undertake limited in-kind replacement rather than replace the materials or entire feature.

Replace Deteriorated Historic Materials and Features If the level of deterioration or damage to character-defining materials or features is very extensive and precludes making appropriate repairs then an entire feature may be replaced in-kind if its essential form and detailing is replicated. Consideration may be given to the use of substitute materials based on technical and economic feasibility and visual impacts.

Design for the Replacement of Missing Historic Features If an important exterior feature is missing its replacement may be necessary or desired. If feasible and appropriate, such replacement should be based on available historical, pictorial or physical documentation. In some cases, it may be feasible to replace a missing feature with a new design that is compatible in size, scale and material selection with the remaining character-defining features of the building.

² See Appendix A for *The Secretary of the Interior's Standards for Rehabilitation*.

³ Please refer to Appendix A for additional preservation definitions/terminology

DISTRICT SPECIFIC DESIGN GUIDELINES

BUILDINGS & STRUCTURES

The following guidelines should be used to guide all work that may be undertaken involving alterations to the exterior of any of the buildings and/or structures located within the landmark district that are not identified as exempted in the Report on Designation.

Cladding Materials

Masonry and/or Cast Stone

- Existing unpainted original brick or cast stone cladding should not be painted.
- Consideration may be given to the removal of non-historic paint from historically unpainted masonry surfaces using cleaning methods recommended by the National Park Service (NPS). Abrasive cleaning methods such as sandblasting shall not be undertaken
- All masonry decorative elements and architectural details should be preserved and/or repaired as needed. Repairs must be undertaken with careful attention given to proper mortar joint type, mortar removal and mix.
- If required, all replacement brick or cast stone elements should be an in-kind match that will not alter the essential form and detailing of the historic cladding. Consideration may be given to the use of substitute materials based on technical and economic feasibility and visual impacts.

Wood

- Every effort should be made to repair wood cladding features by patching, piecing-in, consolidating or otherwise reinforcing the wood using methods recommended by the NPS.
- If required, all replacement wood cladding and trim should be an in-kind match that will not alter the essential form and detailing of the historic cladding.

Corrugated and/or Flat Metal panels

- Every effort should be made to repair metal cladding features by patching, splicing, or otherwise reinforcing the metal using methods recommended by the NPS.
- If required, all replacement metal cladding and features should be an in-kind match that will not alter the essential form and detailing of the historic cladding. Consideration may be given to the use of substitute materials based on technical and economic feasibility and visual impacts.

Corrugated Concrete Panels (or Cementitious Materials)

- If required, partial replacement of damaged areas of cladding or the replacement of all of the cladding may be undertaken. Due to health hazards, the replacement product(s) may be a modern cementitious substitute material; however, the new

cladding material should closely match the essential form, visual appearance and detailing of the historic cladding.

Concrete

- Existing unpainted original concrete walls and building features should not be painted.
- Original unpainted concrete surfaces that have been painted or areas that have been damaged by graffiti may be repainted. Every effort should be made to closely match the color of the original unpainted concrete finish.
- Consideration may be given to the removal of non-historic paint from historically unpainted concrete surfaces using gentle cleaning methods recommended by the NPS.
- All historic concrete elements and architectural details should be preserved and/or repaired as needed with careful attention given to original finish, texture and color.
- Concrete walls and/or features should be repaired by patching, consolidating or otherwise reinforcing damaged or deteriorated areas. Concrete repair work should replicate the old work in strength, composition, color, texture and pattern.
- If required, all replacement concrete features or elements should be an in-kind match that will not alter the essential form and detailing of the historic feature or construction material.

Windows

- Retaining, preserving and in some cases restoring the original historic fenestration pattern (window placement pattern) should be a priority.
- An in-depth survey identifying the condition of the existing window frames and sash should be undertaken prior to any consideration of projects involving the replacement or alteration of window sash or window units.
- Multi-pane steel window sash and frames should be repaired by patching, splicing, consolidating or otherwise reinforcing deteriorated features or components. Such repair may include the in-kind replacement of those parts that are missing or extensively deteriorated. Consideration may be given to the use of substitute materials based on technical and economic feasibility and visual impacts.⁴
- Wooden window sash, frames and trim should be repaired by patching, splicing, consolidating or otherwise reinforcing deteriorated features or components. Such repair may include the in-kind replacement of those parts that are missing or extensively deteriorated. Consideration may be given to the use of substitute materials based on technical and economic feasibility and visual impacts.
- Replacement of historic sash and frame members may be undertaken if it can be demonstrated that the window is too deteriorated to repair and all possible repair

⁴ Consideration for substitute materials will only be given when it can be documented that all options for repair or replacement in-kind have been exhausted and said substitute material is the only remaining feasible option. A life-cycle assessment and life-cycle cost analysis should be carried out to prove the technical and economic feasibility of selecting a substitute material verses repair or replacement in-kind. Important factors to consider include embodied energy, raw material extraction, manufacturing processes, initial cost, future replacement cost, repairs, and maintenance.

and upgrading options have been explored. Replacement sash, pane configuration and frame members should closely match the size and design of the historic sash and frame members. Consideration may be given to the use of compatible substitute materials based on technical and economic feasibility as long as the essential design and character of the window is replicated.

- In order to comply with current energy code requirements every effort should be made to develop design solutions that do not radically change, obscure or alter primary elevations, character-defining features or materials especially fenestration patterns and intact historic window units. Code compliant replacement sash, pane configuration and frame members should closely match the size, configuration and design of the historic sash and frame members. Consideration may be given to the use of compatible substitute materials based on technical and economic feasibility as long as the essential design and character of the window is replicated.
- Restoration of an entire missing original window or replacement of an existing non-historic window may be undertaken. Replacement sash, pane configuration and frame members should be based on available historical, pictorial or physical documentation, and should closely match the size and design of the original historic sash and frame members. Consideration may be given to the use of compatible substitute materials based on technical and economic feasibility assessment (including life-cycle cost analysis) as long as the essential design and character of the original window type is replicated.
- Shutters, louvers, exterior blinds and awnings should not be added to original windows or window openings unless it can be demonstrated that the proposed alteration is based on historic precedent.

Entrances & Porches

- Retaining, preserving and in some cases reestablishing original or historic entrances, entry doors and porches should be a priority.
- Replacement of an historic or original door may be undertaken if it can be demonstrated that the door is too deteriorated to repair and/or function, and all possible repair and upgrading options have been explored. Replacement doors should closely match the size and design of the historic door and frame members. Consideration may be given to the use of compatible substitute materials based on technical and economic feasibility as long as the essential design and character of the door is replicated.
- Restoration of an entire missing original door or replacement of an existing non-historic door may be undertaken. Replacement door products should be based on available historical, pictorial or physical documentation and should closely match the size and design of the original or historic door and frame members. Consideration may be given to the use of compatible substitute materials based on technical and economic feasibility as long as the essential design and character of the original door is replicated.
- The installation of new awnings, canopies or marquees at building entrances is discouraged; however, may be considered if the proposed element and method of attachment will not radically change, obscure or destroy primary elevations,

character-defining features, materials or finishes. The replacement or reconstruction of missing historic awnings, canopies or marquees shall be allowed. Internally-lit awnings or shiny, high-gloss materials will not be allowed.

Architectural Features & Details

- Retaining, preserving and restoring original architectural and decorative features including historic signage and building identification numbers, building ornament and functional elements and historic light fixtures should be of the highest priority.
- All original architectural and decorative (or functional) features should be preserved and/or repaired as needed with careful attention given to the proper treatment of the specific construction materials and details.
- If required, any replacement elements should be an in-kind match that will not alter the essential form and detailing of the feature. Every effort should be made to insure that the feature continues to convey the same visual appearance; however, consideration may be given to the use of substitute materials based on technical and economic feasibility and visual impacts.

Roofs/Roof Features

- Retaining and preserving historic roof forms and their functional and decorative features should be a priority.
- Roof features including roofing materials should be repaired by reinforcing the historic materials. Extensively deteriorated or missing materials or features should be replaced in-kind. If it can be demonstrated that using the same material is not technically or economically feasible, a compatible substitute material may be considered.
- An entire roof feature (i.e. soffit, dormer, chimney) may be partially reconstructed or replaced in-kind if it can be demonstrated that it is too deteriorated to repair. The replacement feature should closely replicate the essential form, design and character of the original feature.

Wood Structural Elements

- Every effort should be made to repair and reuse wooden structural members by patching, piecing-in, consolidating or otherwise reinforcing the wood using methods recommended by the NPS.
- If required, any replacement of wooden structural members should be an in-kind match that will not alter the essential form and character of the structure.

Steel & Metal Clad Doors

- Every effort should be made to repair steel or metal features by patching, splicing, or otherwise reinforcing the metal using methods recommended by the NPS.
- If required, replacement of steel or metal door elements should be an in-kind match that will not alter the essential exterior form and detailing of the original feature. Consideration may be given to the use of substitute materials based on technical and economic feasibility and visual impacts.

Existing Non-Historic Additions/Alterations

- Consideration may be given to the removal of non-historic additions or alterations based on available historical, pictorial or physical documentation.
- Consideration may be given to the alteration of non-historic additions or prior alterations based on available historical, pictorial or physical documentation.
- Any new construction (other than reconstruction) associated with the removal or alteration of non-historic elements should be clearly differentiated from the historic building and be compatible with the adjacent historic materials, features, size, scale and proportion of the building.

Structural Elements

- Alterations or additions to aluminum guardrails, asphalt paving, pilings or other elements that may be original or may have been added to historic structures should be reviewed by the LPB on a case-by-case basis.

New Additions/Exterior Alterations

- Additions or alterations may be necessary or desired in order to adapt a building to a new or an expanded use.
- Such alterations should be considered only after full evaluation has been given to adapting functional changes within the existing interior spaces.
- Exterior additions or alterations should not radically change, obscure or destroy primary elevations, character-defining features, materials or finishes.
- New construction should be clearly differentiated from the historic building such that a false sense of historic appearance is not created *and* should not diminish the historic property or its character-defining features.
- Design for new construction may be contemporary in character or may directly reference design motifs or proportions drawn from the historic building.
- Design of new construction should be compatible in terms of mass, materials, relationships of solids and voids, and color.
- Any new building addition should be constructed in a manner that, if removed in the future, the essential form and integrity of the historic building will be intact.
- New windows may be installed and new window openings on a rear or secondary elevation in order to accommodate a new or expanded use. Window size and proportion should be compatible with the overall design and character of the building but it should not duplicate historic features or create a false historic appearance.
- Rooftop additions when required for a new use (and allowable by code) should be set back from the wall plane and parapet and must be as inconspicuous as possible when viewed from adjacent streets and sidewalks.
- Rooftop mechanical equipment does not necessarily need to be screened, unless required by code. The screening of rooftop mechanical equipment shall be reviewed on a case-by-case basis.

Paint Colors An established palette of appropriate paint colors, typical to the district, was researched and formally identified in 1997 (See Appendix B). The purpose of this paint palette is to unify the landmark district buildings and reinforce the historic character of the district. The following specific guidelines are applicable to the selection of new paint colors for all contributing buildings:

- Exterior wooden cladding - Paint colors should be selected from the established “Building Base Colors” palette
- Colonial Revival style buildings – All wood trim should be painted white.
- Hanger buildings – To be painted light warm gray with contrasting trim and doors to be white or black or equivalent color (per “Building Base Colors” palette).
- All other wood, metal or painted concrete exterior wall surfaces should be painted a warm creamy white (White Solitude #CW 057W)
- Existing historic paint colors on doors, window sash, downspouts and other exterior features may be repainted in-kind.
- Brick masonry, cast stone & unpainted concrete – Existing unpainted brick masonry or concrete, cast stone exterior cladding or associated trim/detail materials should not be painted.
- Project proponents may propose alternative paint colors for consideration based on paint serration/field investigation studies or other factors.
- The application of clear protective treatments to brick, cast stone or concrete must be tested following methods recommended by the National Park Service (NPS).

New Signage & Wall Mounted Lighting

- New wall mounted signage or wall sconce type light fixtures (or security systems) should not radically change, obscure, or destroy primary elevations, character-defining features, materials or finishes. Careful attention must be given to attachment methods that will not damage historic building fabric.
- New signage or wall sconce type light fixtures should be clearly differentiated from historic signage such that character-defining signage is not diminished or a false historic appearance created.
- New signage should adhere to *SMC 23.55.032 Signs in the Sand Point Overlay District*.
- Specific signage designs and light fixtures shall be reviewed on a case-by-case basis. Utilitarian gooseneck type fixtures may be appropriate in some cases.

Accessibility

- Every effort should be made to comply with barrier-free accessibility requirements with design solutions that do not radically change, obscure or alter primary elevations, character-defining features or materials.
- If it is technically infeasible to meet accessibility code requirements and adhere to the above guideline, alternative design solutions are allowed by code.
- The design of new or additional means of access should be compatible with the design of the individual historic building and its building site.
- New ramps, guardrails and handrails should be clearly differentiated from the historic building such that character-defining features are not diminished or a

false historic appearance created. However, it is important that new work be designed with characteristics sympathetic to the historic building and be based on the established palette of design elements and construction materials.

BUILDING SITES & DISTRICT SETTING

The following guidelines should be used to guide work to be undertaken in the immediate vicinity of all buildings (building sites) or within the greater geographic area boundaries of the entire landmark district that may involve potential alterations or changes to the overall setting and character of the district.

View Corridors

- Important on-site view corridors within the landmark district have been formally identified and should be preserved. See map inserted below.

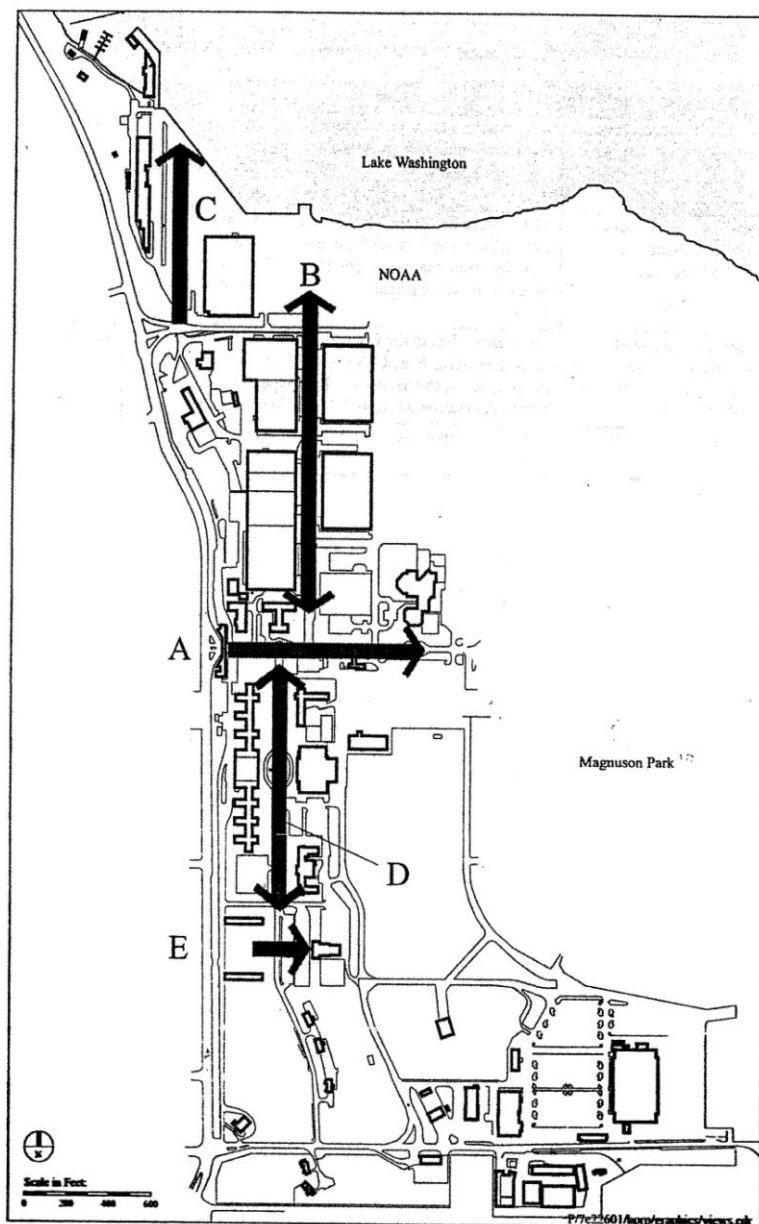

Figure 2-8 Historic View Corridors

2-35

Map Source: Sand Point Historic Properties Reuse & Protection Plan (1998)

Existing Historic Landscape & Site Features

- Various historic landscape and site features including walkways, paths, vegetation, grading, retaining walls and borders are important to the character of the adjacent buildings, their locale and the district setting. Every effort should be made to protect and regularly provide maintenance measures to preserve these features and their relationship to adjacent buildings and the district setting.
- Concrete or masonry features should be repaired by patching, consolidating or otherwise reinforcing damaged or deteriorated areas. Concrete repair work should replicate the old work in strength, composition, color and texture. Masonry elements should be repaired in-kind with careful attention given to proper mortar joint type, mortar removal and mix.
- Any alteration or addition to a site design element, construction material or finish of a contributing object must be reviewed by the LPB on a case-by-case basis.
- Every effort should be made to develop design solutions that do not radically change, obscure or alter a contributing object in order to comply with a new adjacent use or site development requirements.
- Consideration may be given to the relocation of an object on a case-by-case basis.
- If due to extensive deterioration or damage, it is determined that an entire concrete or masonry feature or elements must be replaced, the new work should adhere to the essential form and detailing of the historic feature and convey the same visual appearance. Consideration may be given to the use of substitute materials as long as these guidelines are met.
- Consideration may be given to the replacement of a heavily deteriorated or missing site feature or element as long as the new work is based on available historical, pictorial or physical documentation. New work should closely match the size, essential form and detailing of the historic feature and convey the same visual appearance. Consideration may be given to the use of substitute materials as long as these guidelines are met.

New Landscape or Site Features

- New landscape features or site features should not radically change, obscure or destroy primary elevations, character-defining features, nearby materials or finishes.
- New site features should be clearly differentiated from historic site features such that character-defining features are not diminished or a false historic appearance created. All new site work should be designed in character with the historic building and be based on established design elements and materials.
- New plant materials should be selected from the established *Sand Point Annotated Historic Plant List* (Vegetation Management Plan, 2001) provided by Parks.
- New plant materials should be similar in mass to existing or historic plantings on the building site.
- Plaques or other forms of public display for the purpose of awards or recognition are discouraged. Introduction of new permanently installed objects, monuments or artworks shall be reviewed on case-by-case basis according to potential visual

impacts to views of primary elevations, character-defining features or district setting.

New Street Work & Sidewalks

- New street improvement work should match the appearance of the existing roadway surfaces throughout the district. Typical surfaces are exposed aggregate concrete or asphalt over concrete. Exposed aggregate concrete is the preferred pavement material within the district.
- New or in-kind replacement sidewalk areas must match the appearance of the existing sidewalk surfaces throughout the district in material and design.
- New concrete work must be specified to match aggregate size, color, and proportion of different aggregate mixes.
- New concrete work must be specified to incorporate colorant as necessary to match the existing/historic adjacent concrete color.
- The introduction of “Grasscrete” type products and/or brick or concrete unit pavers may be considered in association with new construction projects according to specific location, visibility and adjacency factors.

New Lighting

- The introduction and design of new street lighting along major streetscapes must follow the established replicated historic light fixture/standards – low or tall fluted cast concrete poles with a simple single globe or tall fluted cast concrete poles down-lights suspended on an arm.
- Low path or pedestrian lighting shall be reviewed on a case-by-case basis according to potential visual impacts to adjacent character-defining site features or the district setting.
- Consideration may be given to the use of a more utilitarian and simple lighting fixture type for minor roadways, less prominent parking areas located away from major streetscapes and/or behind buildings.
- Consideration may be given to adapting the established replicated historic light fixture types to changing technologies that increase energy efficiency.

New Street Furniture

- The introduction and design of new fixed street furniture (including benches, trash receptacles, mailboxes, drinking fountains, bike racks, picnic tables, bollards, and handrails and guardrails) should follow established site furnishing precedents.
- New street furniture should be simple and utilitarian in character and should not create a false sense of historical development.
- Natural wood, galvanized or anodized aluminum, dark-painted steel products, and stainless steel materials are recommended.

New Signage

- New signage must adhere to the *Way-finding Signage Plan* as formally adopted by Parks.

- If new free-standing signage is required it should not radically change, obscure or destroy views of primary elevations or character-defining features or district features.
- New free-standing signage must adhere to *SMC 23.55.032 Signs in the Sand Point Overlay District*.

New Fencing & Screening

- The introduction of new fencing or screening is generally discouraged.
- Galvanized metal chain link fencing is a well-established element within the historic district. The introduction of black-coated chain link fencing may be appropriate in some locations.
- Screening of visually intrusive service areas, utility equipment or storage functions will be allowed. Screening should not have the potential to obscure or destroy views of historic resources, view corridors or nearby site features.
- Fencing for safety or security purposes will be allowed. Fencing should not have the potential to obscure or destroy views of historic resources, view corridors or nearby site features.
- Free-standing ground level mechanical/electrical equipment does not necessarily need to be screened, unless required by code. The screening of mechanical or electrical equipment with galvanized metal chain link fencing shall be allowed.
- Screening design undertaken in association with new construction projects should be simple and utilitarian in character with design elements and materials based on specific location, visibility and adjacency factors.
- Specific fencing or screening designs shall be reviewed on a case-by-case basis.

Accessibility

- Every effort should be made to comply with barrier-free accessibility requirements with design solutions that do not radically change, obscure or alter views of primary elevations, structures, or historic landscape and site features.
- If it is technically infeasible to meet accessibility code requirements and adhere to the above guideline, alternative design solutions are allowed by code.
- The design of new or additional means of access should be compatible with the design of the adjacent historic buildings and the character of the site and setting.
- New ramps, guardrails and handrails should be clearly differentiated from the design of nearby historic buildings such that character-defining features are not diminished or a false historic appearance created. However, it is important that new work be designed with characteristics sympathetic to the district buildings and setting and be based on the established palette of design elements and construction materials.

New Building Construction

Code Requirements

- All new building construction within the landmark district must adhere to the Development Standards as defined in Sand Point Overlay District (SMC 23.72.010).

Design Character

- New buildings should be architecturally compatible with the adjacent historic properties within the district and sensitive to the immediate physical context.
- New construction should be clearly differentiated from historic properties such that a false historic appearance is not created *and* new construction should not diminish the presence of adjacent historic properties or character-defining features.
- The scale, mass, form and proportions of new buildings should be similar in character to adjacent historic properties; however, the specific new use, location and adjacent building types may be taken into consideration.
- Façade composition and fenestration patterns should be similar in character to adjacent historic properties.
- New buildings may be contemporary in character and may reference design motifs and the established palette of construction materials drawn from adjacent historic buildings.

Paint Colors

- An established palette of appropriate paint colors, typical to the district, was researched and formally identified in 1997 (See Appendix B). The purpose of this paint palette is to unify the landmark district buildings and reinforce the historic character of the district. The following guidelines are applicable to the selection of paint colors for new buildings:
- All wood, metal or other painted elements or wall surfaces, windows or trim should be painted in colors that are similar to the colors based on hues included in the established paint palette.
- Brick masonry, cast stone or concrete – new brick masonry, cast stone or concrete exterior cladding or associated brick or stone trim/detail materials should not be painted.
- Project proponents may propose paint colors different from the established palette based on project location or other factors.

APPENDIX A

The Secretary of the Interior's Standards for Rehabilitation

1. A property will be used as it was historically or be given a new use that requires minimal change to its distinctive materials, features, spaces, and spatial relationships.⁵
2. The historic character of a property will be retained and preserved. The removal of distinctive materials or alteration of features, spaces, and spatial relationships that characterize a property will be avoided.
3. Each property will be recognized as a physical record of its time, place, and use. Changes that create a false sense of historical development, such as adding conjectural features or elements from other historic properties, will not be undertaken.
4. Changes to a property that have acquired historic significance in their own right will be retained and preserved.
5. Distinctive materials, features, finishes, and construction techniques or examples of craftsmanship that characterize a property will be preserved.
6. Deteriorated historic features will be repaired rather than replaced. Where the severity of deterioration requires replacement of a distinctive feature, the new feature will match the old in design, color, texture, and, where possible, materials. Replacement of missing features will be substantiated by documentary and physical evidence.
7. Chemical or physical treatments, if appropriate, will be undertaken using the gentlest means possible. Treatments that cause damage to historic materials will not be used.
8. Archeological resources will be protected and preserved in place. If such resources must be disturbed, mitigation measures will be undertaken.⁶
9. New additions, exterior alterations, or related new construction will not destroy historic materials, features, and spatial relationships that characterize the property. The new work shall be differentiated from the old and will be compatible with the historic materials, features, size, scale and proportion, and massing to protect the integrity of the property and its environment.
10. New additions and adjacent or related new construction will be undertaken in such a manner that, if removed in the future, the essential form and integrity of the historic property and its environment would be unimpaired.

⁵ The Landmarks Preservation Board does not have jurisdiction regarding the use of a building or property.

⁶ Protection and preservation of archeological resources is outside the jurisdiction of the LPB and exempt from LPB review.

Definition of other Preservation Terms

Preservation: focuses on the maintenance and repair of existing historic materials and retention of a property's form as it has evolved over time.

Restoration: focuses on the retention of materials/features from the most significant period in the history of the property, while allowing for the removal of evidence from other periods.

Reconstruction: re-creates vanished or non-surviving portions of a property for interpretive purposes.

APPENDIX B

Paint Color Palette

An established palette of appropriate traditional paint colors was researched and formally identified in 1997. The purpose of this paint palette is to unify the landmark district buildings and reinforce the historic character of the district. Samples of the actual paint color palette can be obtained from Parks and/or LPB Staff. The names and formula numbers listed below refer to Parker Paint products; however, equal paint color matches are available from other paint manufacturers.

Building Base Colors

- Whipporwill #8652W
- White Solitude #CW 057W

Building Trim Colors

- Clean Vapour #8610W
- Duberry Red 7896N
- Still Creek #8513M
- Black Deco #AC 144N
- Valley Forge Blue #8506A
- White Solitude #CW 057W

Furnishing & Signage Colors

- Black Deco #AC 144N
- Blue Brilliance #AC 079N

Sand Point - Annotated Historic Plant List

APPENDIX C

Botanical name	Historic Botanical Name	Common name	Historic Common Name	Tree	Shrub	Vine	G'cover	Other	Native	Invasive	Problem
<i>Abelia grandiflora</i>	<i>Abelia grandiflora</i>	Glossy Abelia	Hybrid Abelia		*						
<i>Acer palmatum</i> 'Dissectum Atropurpureum'	<i>Acer atropurpureum</i> dissectum	Red Cutleaf Japanese Maple	Red Cutleaf Japanese Maple	*							
<i>Acer platanoides</i>	<i>Acer platanoides</i>	Norway Maple	Norway Maple	*						*	
<i>Aesculus carnea</i> 'Briotii'	<i>Aesculus rubrus</i>	Red Horsechestnut	Red Horsechestnut	*						*	
<i>Arctostaphylos uva-ursi</i>	<i>Arctostaphylos uva-ursi</i>	Kinnikinnick, Bearberry	Kinn kinnick				*		*		
<i>Aucuba japonica</i> 'Variegata'	<i>Aucuba japonica</i> variegata	Gold Dust Aucuba	Gold Dust Japanese Laurel		*						
<i>Berberis buxifolia</i>	<i>Berberis buxifolia</i>	Magellan Barberrry	Boxleaf Barberrry		*						
<i>Berberis darwinii</i>	<i>Berberis darwinii</i>	Darwin Barberrry	Darwin's Barberrry		*						
<i>Berberis thunbergii</i> 'Atropurpurea'	<i>Berberis atropurpurea</i>	Red-leaf Japanese Barberrry	Purpleleaf Barberrry		*						
<i>Berberis verruculosa</i>	<i>Berberis verruculosa</i>	Warty Barberrry	Leatherleaf Barberrry		*						
<i>Betula pendula</i>	<i>Betula alba</i>	European White Birch	White Birch	*						*	*
<i>Betula pendula</i> 'Dalecarlica'	<i>Betula alba</i> laciniata pendula	Cutleaf Weeping Birch	Cutleaf Weeping Birch	*							
<i>Buxus sempervirens</i>	<i>Buxus sempervirens</i>	Common/English Boxwood	Common/English Boxwood		*						
<i>Buxus sempervirens</i> 'Arborescens'	<i>Buxus arborescens</i>	Tree Boxwood	Tree Boxwood		*						
<i>Camellia japonica</i>	<i>Camellia japonica</i> - Dbl. Red	Double Red Japanese Camellia	Mrs. Tenny's Camelia		*						
<i>Campsis radicans</i>	<i>Bignonia radicans</i>	Trumpet Vine	Trumpet Vine			*					
<i>Catalpa speciosa</i>	<i>Catalpa speciosa</i>	Western Catalpa	Western Catalpa	*							
<i>Cedrus deodara</i>	<i>Cedrus deodara</i>	Deodar Cedar	Deodar Cedar	*							
<i>Celastrus scandens</i>	<i>Celastrus scandens</i>	American Bittersweet	American Bittersweet			*					
<i>Cercis canadensis</i>	<i>Cercis canadensis</i>	American Redbud	American Redbud	*							
<i>Chaenomeles japonica</i>	<i>Cydonia japonica</i>	Japanese Quince	Japanese Quince		*						
<i>Chaenomeles x superba</i> 'Boule de Feu'	<i>Cydonia japonica</i> "Boule d'Feu"	Orange-red Flowering Quince	Japanese Quince - Fireball		*						
<i>Chamaecyparis lawsoniana</i>	<i>Chamaecyparis lawsoniana</i>	Lawson Cypress	Lawson Cypress	*							*
<i>Chamaecyparis lawsoniana</i> 'Allumii'	<i>Chamaecyparis lawsoniana</i> alumn	Allumii Cypress	Alumni Cypress	*							
<i>Chamaecyparis obtusa</i> 'Aurea'	<i>Thuja obtusa</i> aurea	Golden Hinoki Cypress	Gold Hinoki Cypress	*							
<i>Chamaecyparis pisifera</i>	<i>Retinospora squarrosa</i>	Sawara False Cypress	Fizzy Retinospora	*							
<i>Chamaecyparis pisifera</i> 'Filifera'	<i>Retinospora pisifera</i> filifera	Threadleaf False Cypress	Thread Retinospora	*	*						
<i>Choisya ternata</i>	<i>Choisya ternata</i>	Mexican Orange	Mexican Orange		*						
<i>Clematis jackmanii</i>	<i>Clematis jackmanii</i>	Jackmanii Clematis	Purple Clematis			*					
<i>Cornus florida</i> 'Rubra'	<i>Cornus florida</i> rubra	Pink Eastern Dogwood	Red Flowering Dogwood	*							*
<i>Cornus nuttallii</i>	<i>Cornus nutallii</i>	Pacific/Western Dogwood	Pacific/Western Dogwood	*					*		*
<i>Cotoneaster franchetti</i>	<i>Cotoneaster franchetti</i>	Franchet Cotoneaster	Broadleaf Cotoneaster		*					?	
<i>Cotoneaster microphyllus</i>	<i>Cotoneaster microphylla</i>	Rockspray Cotoneaster	Small Leaf Cotoneaster		*		*				
<i>Cotoneaster pannosus</i>	<i>Cotoneaster pannosa</i>	(Evergreen) Cotoneaster	Silverleaf Cotoneaster		*						
<i>Cotoneastersalicifolius</i> rugosus ?	<i>Cotoneaster rugosa</i> henryi	(Evergreen) Cotoneaster	Weeping Cotoneaster		*					?	
<i>Crataegus laevigata</i> 'Paul's Scarlet'	<i>Crataegus oxycantha</i> pauli	Paul's Scarlet Hawthorn	Paul's Scarlet Hawthorn	*						?	*
<i>Cytisus purpureus</i>	<i>Cytissus atropurpurea</i>	Purple Broom	Lavendar Broom		*					?	
<i>Cytisus scoparius</i> 'Andreanus'	<i>Cytissus andreanus</i>	Andreanus Broom	Redwing Broom		*					?	
<i>Cytisus scoparius</i> 'Dragonfly'	<i>Cytissus dragonfly</i>	Dragonfly Broom	Garnet Wing Broom		*					?	
<i>Cytisus scoparius</i> 'Moonlight'	<i>Cytissus praecox</i>	Moonlight Broom	Moonlight Broom		*					?	
<i>Daboecia cantabrica</i>	<i>Dabolcia purpurula</i>	Irish Heath	Purple Irish Heath		*		*				
<i>Daphne cneorum</i>	<i>Daphne cneorum</i>	Garland Daphne	Dwarf Daphne		*		*				*

NOTES:

Historic names - taken from extant period planting plans and lists.
 Botanical and common names - most probable modern equivalent.
 Invasive and Problem taxa - avoid future use.
 Natives - habitat, aesthetic uses.

Sand Point - Annotated Historic Plant List

Botanical name	Historic Botanical Name	Common name	Historic Common Name	Tree	Shrub	Vine	Gr'cover	Other	Native	Invasive	Problem
Daphne mezereum ?	Daphne serium	February Daphne	Early Daphne		*						
Daphne odora	Daphne odora	Winter Daphne	Fragrant Daphne		*						
Erica australis ?	Erica stricta	Southern Heath	Upright Heather		*						*
Erica darleyensis ?	Erica hybrida	Hybrid Winter Heath	Christmas Heather		*		*				
Erica mediterranea hybrida ? (= darleyensis)	Erica mediteranean hybrid	Hybrid Winter Heath	Christmas Heather		*		*				
Erica vagans 'Mrs. D.R. Maxwell'	Erica vagans rubra	Red Cornish Heath	Red Cornish Heather		*		*				
Forsythia suspensa	Forsytaia suspensa	Weeping Forsythia	Weeping Golden Bell		*						
Fuchsia magellanica	Fuchsia - Hardy Bush Type	Hardy Fuchsia	Mrs. Tenny's Fuchsia		*						
Genista hispanica	Genista hispanica	Spanish Broom	Dwarf Spanish Gorse		*						
Gleditsia triacanthos	Gledistia triacanthos	Honey Locust	Honey Locust	*							*
Hebe hectoris	Veronica hectori	Dwarf Hebe	Whipcord Veronica		*						
Hedera helix 'Conglomerata'	Hedera helix conglomerata	Conglomerata Ivy	Bunchleaf Ivy			*	*				
Heilanthemum nummularium cultivar	Hellanthemum "Copper Queen"	Copper Red Sunrose	Sunrose - "Copper Queen"		*		*				
Hydrangea macrophylla 'Hamburg' ?	Hydrangea hortensis	Red Bigleaf Hydrangea	Red Japanese Hydrangea		*						
Hypericum calycinum	Hypericum calycinum	Creeping St. John's Wort	St. John's Wort		*		*			*	
Jasminum nudiflorum	Jasminum nudiflorum	Winter Jasmine	Winter Jasmine		*						
Juniperus sabina 'Tamariscifolia'	Juniperus tamariscifolia	Tam Juniper	Gray Carpet Juniper		*		*				
Juniperus chinensis 'Pfitzerana'	Juniperus pfitzeriana	Pfitzer Juniper	Pfitzers Juniper		*						
Kalmia latifolia	Kalmia latifolia	Mountain Laurel	Mountain Laurel		*						
Kerria japonica	Kerria japonica	Kerria	Globe Flower		*					?	
Laburnum anagyroides	Laburnum vulgare	Common Goldenchain Tree	Common Goldenchain Tree	*						*	
Lavandula angustifolia 'Hidcote' ?	Lavendula spicea	Dwarf English Lavender	Dwarf Lavender		*		*				
Ligustrum japonicum	Ligustrum japonicum	Wax-leaf Privet	Japanese Privet		*						
Ligustrum ovalifolium	Ligustrum ovalifolium	California Privet	California Privet		*					?	
Lonicera nitida	Lonicera nitida	Box Honeysuckle	Box Honeysuckle		*						
Lycium barbatum	Lycium chinese	Chinese Box Thorn	Chinese Matrimony Vine		*						
Magnolia aquifolium	Magnolia aquifolium	Tall Oregon Grape	Oregon Hollygrape		*				*		
Magnolia tripetala	Magnolia tripetala	Umbrella Tree	Mrs. Tenny's Magnolia	*							
Mahonia nervosa	Mahonia nervosa	Low Oregon Grape	Native Oregongrape		*		*		*		
Malus 'Red Delicious'	Espalier apple	Red Delicious (espalier)	Red Delicious Apple	*							*
Malus Sieversii 'Niedzwetzkyana'	Malus neidwetzkyana	Redvein Crabapple	Redvein Crab	*							*
Morus alba 'Pendula'	Morus alba pendula	Weeping Mulberry	Weeping Mulberry	*							
Nandina domestica	Nandina domestica	Heavenly Bamboo	Sacred Japanese Bamboo		*						
Nymphaea marliacea 'Chromatella'	Marlicacea chromatelia	Canary Yellow Waterlily	Canary Yellow Waterlily					*			
Pernettya mucronata 'Atrococcinea'	Pernettya rubra	Ruby Pernettya	Red Pernettya		*						
Pernettya mucronata 'Lilacina'	Pernettya lilacina	Lilac Pernettya	Violetberry Pernettya		*						
Pernettya mucronata 'Rosie' ?	Pernettya rosea	Pink Pernettya	Pinkberry/Rose Pernettya		*						
Philadelphus virginialis 'Virginal'	Philadelphus virginal	Hybrid Double Mock Orange	Double Mock Orange		*						
Photinia serrulata	Photinia serrulata	Chinese Photinia	Toothleaf Photinia	*	*						
Picea pungens 'Koster'	Picea kosteriana - Christmas Tree	Koster Blue Spruce	Koster's Blue Spruce	*							*
Pieris floribunda	Andromeda catasbaei	Mountain Andromeda	Lily of the Valley Bush		*						
Pieris japonica	Andromeda japonica	Japanese Pieris	Japanese Andromeda		*						

NOTES:

Historic names - taken from extant period planting plans and lists.
 Botanical and common names - most probable modern equivalent.
 Invasive and Problem taxa - avoid future use.
 Natives - habitat, aesthetic uses.

Sand Point - Annotated Historic Plant List

Botanical name	Historic Botanical Name	Common name	Historic Common Name	Tree	Shrub	Vine	Gr'cover	Other	Native	Invasive	Problem
<i>Pinus thunbergiana</i>	<i>Pinus thunbergi</i>	Japanese Black Pine	Japanese Black Pine	•							
<i>Populus nigra</i> 'Italica'	<i>Populus nigra italica</i>	Lombardy Poplar	Lombardy Poplar	•						•	•
<i>Prunus blireiana</i>	<i>Prunus blireiana</i>	Blireiana Plum	Double Purple Plum	•							•
<i>Prunus ceracifera</i> 'Atropurpurea'	<i>Prunus pissardi</i>	Purple-Leaf Plum	Purpleleaf Plum	•							
<i>Prunus domestica</i> ?	Espalier plum	European Plum (espalier)	Plum - Flat-Trained	•							
<i>Prunus laurocerasus</i>	<i>Laurocerasus officinalis</i>	English Laurel	English Laurel	•	•					•	
<i>Prunus lusitanica</i>	<i>Laurocerasus lusitanica</i>	Portugal Laurel	Portugal Laurel	•	•					•	
<i>Prunus serrulata</i> 'Kwanzan'	<i>Prunus serrulata</i> 'Kwanzan'	Kwanzan Japanese Cherry	Kwanzan Japanese Cherry	•							•
<i>Prunus subhirtella</i> 'Pendula'	<i>Prunus subhirtella pendula</i>	Single Weeping Cherry	Weeping Japanese Cherry	•							•
<i>Pyracantha coccinea</i> 'Lalandei'	<i>Pyracantha lalandi</i>	Orange Firethorn	Laland Firethorn		•					?	
<i>Pyrus communis</i> 'Bartlett'	Espalier pear	Bartlett Pear (espalier)	Bartlett Pear	•							
<i>Rhododendron</i>	<i>Azalea citrinus</i>	Azalea	Lemon Azalea		•						
<i>Rhododendron</i>	<i>Azalea amoena superba</i>	Azalea	Claret Pink Azelea		•						
<i>Rhododendron</i> 'Hinodegiri'	<i>Azalea hinodoiiri</i>	Hino Crimson Azalea (evergreen)	Scarlet Azalea		•						
<i>Rhododendron</i> 'Pink Pearl'	<i>Rhododendron</i> 'Pink Pearl'	Pink Pearl Rhododendron	Pink Pearl Rhododendron		•						
<i>Rhododendron kaempferi</i>	<i>Azalea kaempfer</i>	Torch Azalea (evergreen)	Torch Azalea (evergreen)		•						
<i>Rhododendron mollis</i>	<i>Azalea mollis</i>	Mollis Azalea (deciduous)	Chinese Azalea		•						
<i>Rhododendron occidentale</i>	<i>Azalea occidentalis</i>	Western Azalea (deciduous)	Western Azalea (deciduous)		•				•		
<i>Rhododendron ponticum</i>	<i>Rhododendron ponticum</i>	Ponticum Rhododendron	Lavender Rhododendron		•						
<i>Rhododendron</i> x 'Altaclarensis'	<i>Azalea altaclarensis</i>	Orange Mollis Azalea (deciduous)	Yellow/Orange Azalea		•						
<i>Rhus glabra</i> 'Laciniata'	<i>Rhus glabra</i> laciniata	Cutleaf Smooth Sumac	Cutleaf Sumac	•	•				?	?	
<i>Rosa</i> 'Climbing Kaiserin Auguste Viktoria'	<i>Rosa kaiserine</i> 'Augusta Victoria'	White Climbing Hybrid Tea Rose	White Climbing Rose			•					
<i>Rosa</i> 'Paul's Scarlet Climber'	<i>Rosa</i> "Paul's Scarlet"	Red Climbing Rose	Scarlet Climbing Rose			•					
<i>Sarcococca hookerana humilis</i>	<i>Sarcococcus hookeriana</i>	Low Sarcococca	Hooker's Sarcococcus		•		•				
<i>Sorbus aucuparia</i>	<i>Sorbus aucuparia</i>	European Mountain Ash	Mountain Ash	•						•	•
<i>Sorbus aucuparia</i> 'Pendula'	<i>Sorbus aucuparia pendula</i>	Weeping Mountain Ash	Weeping Mountain Ash	•						?	•
<i>Spiraea bumalda</i> 'Anthony Waterer'	<i>Spiraea</i> "Anthony Waterer"	Anthony Waterer Spiraea	Deep Rose Bridalwreath		•						
<i>Stranvaesia davidiana</i>	<i>Stranvaesia davidiana</i>	Stranvaesia	David's Strandwesia	•	•					?	
<i>Styrax japonicus</i>	<i>Styrax japonica</i>	Japanese Snowdrop Tree	Mrs. Tenny's Lily-of-the-Valley Tree	•							
<i>Syringa vulgaris</i> 'Charles Joly'	<i>Syringa</i> "Charles Joly"	Purple-red French Lilac	Lilac "Charles Joly"		•						
<i>Syringa vulgaris</i> 'Madame Lemoine' ?	<i>Syringa</i> "Mme. Lemqine"	Double White French Lilac	Double White Lilac		•						
<i>Taxus baccata</i>	<i>Taxus baccata</i>	English Yew	English Yew	•							
<i>Taxus baccata</i> 'Stricta'	<i>Taxus hibernicus</i>	Irish Yew	Irish Yew (green)	•							
<i>Thuja occidentalis</i> 'Fastigiata'	<i>Thuja orientalis</i> pyramidalis	Arborvitae/Pyramidalis	Pyramidal Arborvitae	•							•
<i>Tsuga heterophylla</i>	<i>Tsuga hetrophylla</i>	Western Hemlock	Pacific Hemlock	•					•		?
<i>Ulmus americana</i>	<i>Ulmus americana</i>	American Elm	American Elm	•							•
<i>Ulmus parvifolia</i>	<i>Ulmus parvifolia</i>	Chinese Elm	Chinese Elm	•							
<i>Viburnum davidii</i>	<i>Viburnum davidianum</i>	Davidii Viburnum	Dwarf Evergreen Snowball		•		•				
<i>Viburnum rhytidophyllum</i>	<i>Viburnum rhytidophyllum</i>	Leatherleaf Viburnum	Evergreen Snowball		•						
<i>Viburnum tinus</i>	<i>Viburnum tinus</i>	Laurustinus	Laurestinus		•						
<i>Vinca minor</i>	<i>Vinca minor</i>	Periwinkle	Trailing Myrtle			•	•			?	
<i>Weigela florida</i> 'Eva Rathke'	<i>Weigelia</i> "Eva Rathke"	Red Compact Weigela	Rose Weigelia		•						
<i>Wisteria sinensis</i>	<i>Wisteria chinensis/sinensis</i>	Chinese Wisteria	Purple/Chinese Wisteria			•					

NOTES:

Historic names - taken from extant period planting plans and lists.
 Botanical and common names - most probable modern equivalent.
 Invasive and Problem taxa - avoid future use.
 Natives - habitat, aesthetic uses.



Warren G. Magnuson Park
Seattle Parks & Recreation



Signage & Wayfinding Master Plan
Final Design

December 22, 2004

KellyBrandonDesign

Table of Contents	Page
Introduction Description of the process & additional design information to supplement the following design drawings	1
Sign Specifications Standard written specifications for use when bidding each signage procurement package; standard CSI format, includes general color specifications	10425-1
Basic Sign Types List the functional sign types for use in main park areas w/ descriptions of intended uses; not for construction	ST-1 thru 4
Tenant Sign Types List of tenant sign types meant to satisfy major tenant signage needs	T-1 & 2
Basic Sign Dimensions Overall dimensions & configuration drawings with references to details; used for construction of the sign types	STDD-1 thru 7
Tenant Sign Dimensions Overall dimensions & configuration drawings with references to details; used for construction of the tenant sign types	TDD-1 & 2
Site Plan A list of place names and nomenclature and typical sign locations by sign type	C-1 & 2

Introduction

This document is the final phase of a multi-phase program to develop a set of signage and wayfinding standards for Magnuson Park, a major urban park in the Seattle Parks system.

During the survey and programming phases of the project, information was gathered from staff and local park users about the park's operation and its signage needs. Creating a set of standards which would solve the unique signage and wayfinding needs of this particular park was a primary objective. Discussions were conducted with the Seattle Parks sign shop to determine how signage is currently created and maintained and to what degree the programmatic needs of a typical Seattle park were similar to the needs of Magnuson Park.

Public meetings were held after each steering committee meeting to solicit input from the resident tenant organizations and local park users in the neighborhood. Recommendations from all these sources has been incorporated into these final design standards.

When creating a set of design standards it is necessary to make some assumptions regarding the time frame for implementation, the mode and means of construction, and the likely packaging and sizes of procurement elements. In addition, when funding will not allow any construction to occur until a date after the standards are completed, it should be expected that any first implementation will contain the need for changes, adjustments, and corrections. During this project no full size mock-ups or prototypes were made, so this should be part of any first phase funding. Only after all of the sign types have been actually constructed can these documents truly be said to be "standards."

Organization of the Standards

The method used here is based on the creation of a series of "functional categories," each of which fulfills a particular signage and wayfinding need. An example would be the need to label the various buildings, the need to place vehicular directions along a main road, or the need to provide a map for the orientation of the park user.

The first group of drawings consists of colored representations of each sign type with brief description about its use and where it typically would be located in relation to a particular part of the park.

The second section consists of detailed elevations of each sign type, complete with dimensions and keys to details of construction, and a series of typical details used in the construction of the signs.

Supplemental Sign Type Comments

In addition to the narrative provide on pages ST-1 through 4 and T-1 & 2, here are some additional guidelines regarding the intended use of the various sign types.

A01 - Large Vehicular Directional

This is the basic directional sign for use on all roads, along with it's cousin, the A02. These sign should be located to the right side of the road, generally just beyond the point of turn or decision, so that the turn itself remains in the driver's view while looking at the sign. Avoid locating these signs too far in advance of any turn which is indicated on the sign. MUTCD regulations suggest the use of a "break-away" leg design and the use of a "fuse plate" just beneath the sign face itself to encourage the sign to break at that point should it ever be hit by a car. These regulations were originally designed for use on steel post signs and because the Magnuson Park system has an aluminum leg, the buckling quality is essentially built-in.

A03 - Pedestrian Directional, Tall

Use this sign sparingly, since its size will logically attract the attention of vandals and may suffer abuse in remote areas. Use it when the sign information must be seen above cars, foliage, or other obstructions.

A04 - Pedestrian Directional, Short

This sign will commonly be used on the nature trails, trail heads, and in the non-urban parts of the park where foot traffic needs directional information.

A05 & A06 - Accessible Route Signs

This sign should only be used when the accessible route and its relative hazards cannot be seen from the normal point of approach. If you can see the ramp or if the slope is obviously too steep for a wheelchair, it is not necessary to post a sign. Only where the visitor might roll a long way down the wrong path if not informed would these signs be used.

B01 - Large Destination I.D.

The symbolic illustration at the top of the sign is intended to be approximately the size shown and very friendly and "cartoonish" in character. Avoid illustrations with too many sharp or thin projections and be sure that the image projects over the sign only the minimum amount to highlight its presence. Since many of the areas are large, it may be necessary to locate more than one such sign to mark the identity of the area.

B02 - Special Activity I.D.

This is a cousin of the B01, being smaller and more frequent in the park. Be particularly careful about letting the illustration project above the top of this sign, since it is lower and therefore within public reach. This sign should be seen as a smaller, less expensive version of the B01.

B03 - Large Building I.D.

This sign comes in two basic version: one for tenant use and one for major park functions. If the entire building is one tenant, it is possible to use this sign at each entrance and use the corporate colors and logo of the tenant. If the building houses a major park function, such as the Seattle Parks offices, or a named public facility, such as the Recreation Center, the sign should use the background color of the region it occupies, and the standard park typeface and park logo. The B05 is a smaller version of B04. Both rely on the use of address numbers or historic building numbers to be effective in general address wayfinding.

B06 - Historic Building Numbers

These must be used on buildings which are being preserved in their original form and which traditionally have had such number designations. Some buildings, such as the Officers Quarters, never did have a formal number, just a painted one. Every effort should be made to replace such ad hoc numbers with new, standard typeface numbers.

B07 - Typical Address Numbers

These should appear on all buildings in the Historic District, since the street address is the primary means of wayfinding. Although the standard typeface should be used, the color and material may be adjusted to look at home on the different building materials.

B10 & B11 - Restroom Signs

These signs need to be very vandal-resistant because of their location in unsupervised areas. The aluminum construction makes the face durable and full adhesive mounting is recommended. The B11 sign projects from a wall surface to make it more visible from a side approach, but this makes the structure more vulnerable to vandalism. The aluminum tube construction beneath the aluminum face allows this sign to be sturdy. Be sure that anchors into concrete or other wall surfaces are over-designed to make this sign vandal-resistant.

C01 & C02 - Campus Directory Maps

These maps are the key to general orientation in the park and the artwork for the map needs to match the maps presented in web maps and brochures available to the public. In addition, the map is made from embedded melamine, an extremely durable material, and the map element itself can be changed as updates are required. The location of the C01 will depend on adjusting the entry road configurations to allow the driver to approach the map with it on the left side of the vehicle for closer viewing.

N01 - Interpretive Sign

The interpretive program will need programmatic development, but this particular lower style of sign is especially suited for "overlook" points and areas where a tall sign is inappropriate. The C01 & C02 signs can be used for interpretive purposes if desired.

R01, R02, R03 - Traffic & Street Signs

These three sign types are included to ensure that the park streets are properly signed according to City of Seattle standards. Much improvement in wayfinding will result from bringing the park up to normal practice for similar streets elsewhere in the city.

It is possible, for cost reasons, to specify only standard posts and signs for all three of these categories, but the use of a custom pole and sign blade for the R03 will add distinction to the park system.

R04 - Park Rules

The intent of this type is to improve the legibility and clarity of the various park rules by simplifying and shortening the text involved, while still maintaining the intent of the ordinances. Legal counsel should review the revised text to be sure it still meets statute requirements for enforcement. The new color and format will draw new attention to these old rules.

T01 - Tenant Directory

This sign helps consolidate the tenant identities at a point on the road system where all the tenants will want a presence. The final structure should allow tenants to change easily and the sign must always carry the reference to the building number, street address, or park functional name. Use it to signal the location of tenants.

T03 & T04- Tenant I.D.

The exact size and proportion of these signs will change from building to building, since the available space will vary. Be sure to confer with current tenants to ensure proper location and dominance. Buildings with many tenants will necessarily have smaller signs for each tenant.

T06 & T07 - Temporary Event Totem & Banner Trellis

In order to curb the increasing number of temporary event A-boards which appear on the campus, the T06 signs are located at all entrance intersections to intercept traffic headed for special events. Organizers should be given information about the T06 and size/color/typeface standards for temporary signs which they can have made and install into the totems themselves. Removal should be the organizer's responsibility and might be written into the event contract with the park.

The T07 is a multiple version of the T06 and is intended to hold banners and larger announcements of temporary events. Neither of these signs types should allow permanent tenant advertising; all events thus-posted must be date-specific and the banner removed at the end of the event.

Landscape Suggestions

Since many of the signs in the master plan will be located in grassy areas, there are measures which can be taken to minimize the maintenance around the sign posts.

For signs in grassy areas, consider placing paver blocks, or "mow blocks" between and around the legs of the sign. This prevents grass from growing in this area and gives a clean edge for the lawn mowers to trim against. The blocks may be any concrete or brick material, provided they are embedded into the soil and match the character of the buildings around the sign. Some planting between sign legs is OK, as long as it doesn't obscure the view of the sign text.



Existing Logo

New Park Logo

Part of the signage master plan assignment was to study the the existing park logo and Seattle Parks logo and determine how these two identities should best work together.

The recommendation of this report is that the existing Seattle Parks logo is a functional part of the signage and should be used wherever system identity needs to be reaffirmed, such at the entrances to the park.



Naval Aviation Theme

On park grounds, a modified version of the existing Magnuson Park logo should be used, as indicated on the sign types. Since the Flight Memorial may be moved in the future, the image of this tall monument will not always be part of the park's character. Rather, the Historic District and the history of the naval air station seem stronger links. The existing logo make a good deal of the Art Deco style and this study recommends for that approach to continue.



Nature Theme

The two directions which seem most promising are:

1. A logo which emphasizes the historic aviation uses of the park, but featuring a Douglas biplane over the Magnuson Park name.
2. A logo which emphasizes the natural amenities of the park and features birds in flight over the Magnuson Park name.

Additional logo development will be required before actual implementation to determine public acceptance of one of these two directions. Once adopted, this park-specific logo should be used on Magnuson Park stationery as well as the Seattle Parks web page for the park.

City of Seattle – Warren G. Magnuson Park
SECTION 10425 - SIGNAGE

PART 1 - GENERAL

1.1 RELATED DOCUMENTS

- A. Drawings and general provisions of the Contract, including General and Supplementary Conditions and Division 1 Specification Sections, apply to this Section.

1.2 SUMMARY

- A. Description of the Work: This work shall consist of the fabrication and installation of permanent exterior signage in accordance with these Specifications, and all applicable codes.
- B. Scope of the Work: The scope of this work is contained in these Specifications, Sign Schedule and Details. The Contractor shall provide all necessary materials, labor, equipment and accessories to form a completed sign installation.

1.3 SUBMITTALS

- A. Manufacturers Technical Data: Submit 4 sets of data indicating the basic properties of each material or pre-manufactured product.
- B. Shop Drawings: Submit 4 sets of scaled drawings indicating the intended construction details of each sign type. Drawings shall include verified field dimension for installation and notations of all variations from the design which the Contractor is suggesting for any reason.
- C. Samples: Provide samples of all materials and processes to be used in the fabrication and installation. 4 sets of samples shall be submitted to the Designer for internal review and approval.
- D. Prototype Sign Types: Provide a prototype of each sign type specified in the Project Manual when indicated in the Project Drawings. All final materials, processes and colors shall be used in the fabrication of the prototype. Larger signs may be partial prototypes of a major portion of the full sign which shows all edge, corner and finish conditions. Whole sign prototypes which are approved may be used in the final installation.
- E. Color Samples: Provide 4 sets of color samples of all sign materials used in the project. If the color is integral with the material sample submitted in C. above, no additional color sample is required. If the color is custom paint, stain or other special process, provide 12"x12" samples.
- F. Computer-Cut Typography Samples: Provide 4 sets of each size and style of vinyl letter. Typography which will be fabricated from other materials shall be approved via the sign pattern layouts submitted in G. below.

City of Seattle – Warren G. Magnuson Park
SECTION 10425 - SIGNAGE

- G. Sign Face Layouts: Submit 4 sets of sign face layouts for each Sign Type. Indicate all line spacing, margins and variations in word length caused by variations in the message content of each Sign Type.
- H. Coordination of Submittals: All samples and submittal materials required in this article shall be submitted together; if any part of the required submittals is missing, the review process will be stopped until the balance of the submittal materials are received. The contractor may be liable for the cost of delays caused by such incomplete submittals.
- I. Sign Copy: All final copy will be provided to the fabricator by the Architect during the shop drawing review period. Bids shall be based on the Sign Schedule, the estimated copy shown for that Sign Type or the copy as shown in the example drawings. Copy sizes may vary slightly from examples shown.

1.4 SITE CONDITIONS

- A. Examination of Site: The Contractor shall visit and examine the site prior to bidding and in sufficient detail before installation to determine the existence of all field conditions which bear on the signage work.
- B. Substrata Conditions: The Contractor is responsible for acceptance of all substrata for the installation of signage. All existing conditions shall be inspected by the Contractor prior to installation; if any conditions exist which are detrimental to the signs or their installation, he shall notify the Owner before any signs are installed so that the conditions may be corrected.
- C. Climatic Conditions: The Contractor shall visit the site of the signage installation and verify that conditions of humidity and temperature are suitable for the delivery of sign materials or fabricated signs. The Contractor shall be responsible for such suitability and shall notify the Owner if any site conditions exist which are detrimental to the signs for their delivery or storage.

1.5 INDUSTRY STANDARDS REFERENCES

- A. All miscellaneous screws, bolts, plates, anchors, welds and steel used in the construction or installation of the signage shall comply in their execution and quality with the following authorities, as applicable: American Institute of Steel Construction (AISC), American Society for Testing and Materials (ASTM), American Welding Society (AWS) and American National Standards Institute (ANSI). All such miscellaneous materials shall be of a grade suitable for commercial construction and compatible with existing construction materials.

1.6 AMERICANS WITH DISABILITIES ACT OF 1990

- A. The Contractor shall comply with all accessible signage provisions of the ADA and the UBC, current edition. If any aspect of the design does not meet these requirements, the

City of Seattle – Warren G. Magnuson Park
SECTION 10425 - SIGNAGE

Contractor shall notify the Designer during the bidding process so that an addendum can be issued.

1.7 WARRANTY

- A. The Contractor shall warrant all signs against defects in material, finish, structural integrity, operation, general appearance and electrical parts, except lamps, for a period of five (5) years. Lamps shall be warranted for a minimum of one (1) year. Originals of all warranty documents from material or subsystem equipment suppliers shall be forwarded to the Owner.

PART 2 - PRODUCTS

2.1 SIGN TYPES

- A. Provide the quantity of each Sign Type indicated in the Sign Schedule and in the design as shown in the Details and Specifications. Locate each sign as indicated in the Drawings except locate Sign Types not shown in the Drawings as directed by the Owner. The materials specified in this Section are used in the design of one or more of the listed Sign Types. Material or accessories required for the construction or installation of the Sign Types, but which are not listed here, shall be submitted to the Architect for review and approval.

2.2 MATERIALS

- A. Where specified in the design drawings, all materials shall meet the specifications listed below:
 - 1. Aluminum Tubing: Conform to ASTM Standard B210-02 "Standard Specification for Aluminum and Aluminum-Alloy Drawn Seamless Tubes". Provide square-cornered standard extrusions in outside widths as show on the drawings and with wall thickness suitable for the structural loading of the installed sign. Provide Alloy 6063 unless otherwise indicated.
 - 2. Aluminum Angles: Conform to ASTM Standard B211-02 Standard Specification for Aluminum and Aluminum-Alloy Bar, Rod, and Wire. Provide angles in Alloy 6063 unless otherwise specified.
 - 3. Aluminum Sheet & Plate: Conform to ASTM Standard B209-02a Standard Specification for Aluminum and Aluminum-Alloy Sheet and Plate. Provide aluminum sheet in Alloy 5052 in .080" thickness unless otherwise specified. Provide aluminum bars in Alloy 6063 unless otherwise specified.
 - 4. Paint: Provide Matthews Paint Company (or approved equal) exterior grade acrylic polyurethane paint system in the colors specified.

City of Seattle – Warren G. Magnuson Park
SECTION 10425 - SIGNAGE

5. Vinyl Letters: 1 mil thickness, "3M", commercial grade vinyl letters, custom cut to specified typeface using EPS plot files provide by Owner or approved resident fonts submitted by fabricator.
6. Impact Resistant Polycarbonate Sheet: Where indicated on the drawings provide clear, polycarbonate sheet as manufactured by GE, "Lexan", or approved equal.
7. Embedded Graphics Laminate: For campus maps, provide embedded graphic laminate map panels as manufactured by WilsonArt, "iZone", or approved equal. Laminate each embedded melamine graphic sheet to 1/8" black phenolic sheet for stability and mount to sign face with fasteners as indicated.
8. Cut Metal Letters: For all cut metal letters indicated on the drawings provide 1/4" aluminum or stainless steel which has been cut to the specified typeface by high-pressure water-jet or similar precision machine cutting technique. Fabricator shall cut to specified typeface using EPS plot files provide by Owner or approved resident fonts submitted by fabricator. Affix the letters to exterior wall by means of a series of threaded rods tapped into the back of each letter and then fixed into holes in the wall by means of silicone mastic or adhesive appropriate to the wall material. Provide a minimum of three rods for all wide letters and two rods for narrow, single-stroke letters.
9. Waterproof Digital Print: Provide waterproof digital prints for all logos as manufactured by Gerber, "Gerber Edge", or approved equal. Affix to sign face using exterior grade VHB tape or sheet adhesive.
10. VHB (Very High Bond) Tape or Adhesive Sheet: Provide VHB tape as manufactured by 3M Company, Adhesive Products Division, USA. Only use this product to fasten two unpainted aluminum surfaces when used as the main structural connection. Use heat and pressure according to manufacturer's instructions to insure a full strength bond.
11. Premanufactured Signage Systems: Where standard sign products are indicated, the manufacturers' names and catalog numbers listed establish the standard and quality required, but are not restrictive. Similar and equal products of other manufacturers may be submitted for approval of the Architect under provisions of Section 01600 - Materials, Equipment, and Product Substitutions.
12. Cut Plastic Letters: For all cut metal plastic indicated on the drawings provide 1/4" acrylic or 1/4" "Sintra" expanded polyurethane foam sheet which has been cut to the specified typeface by a precision machine cutting technique. Fabricator shall cut to specified typeface using EPS plot files provide by Owner or approved resident fonts submitted by fabricator. Affix the letters to exterior wall by means of a series of threaded rods tapped into the back of each letter and then fixed into holes in the wall by means of silicone mastic or adhesive appropriate to the wall material. Provide a minimum of three rods for all wide letters and two rods for narrow, single-stroke letters.
13. Composite Aluminum/Neoprene Panel: As manufactured by AlucoBond or DiBond, or approved equal.

2.3 COLOR SPECIFICATIONS

- A. The colors for all design elements in the project are below. These Color Numbers correspond to the following color matching references or manufacturer's color numbers:

City of Seattle – Warren G. Magnuson Park
SECTION 10425 - SIGNAGE

Color P1 – Historic District “Brick” match Matthews “Burgundy Dash” #7A-1A Color P2 – Shoreline “Teal” match Matthews “Cypress Blue” #64A-1A or PMS #303C
Color P3 – Neutral Sign Body Color: Warm Grey: Matthews “Mole” #26C-2T
Color P4 - Dark Bronze
Color P5 - Access Blue, match PMS 3035C
Color P6 – Safety Yellow, match PMS 123C
Color P7 – Safety Red, match PMS 185
Rainbow Panel Colors:
Ivory: Plexiglas #2146 or Matthews “Leek” #49B-1P
Red: Plexiglas #2793 or Matthews “Spectrum Red” #5A-1A
Orange: Plexiglas #2119 or Matthews “Really Orange” #18A-1A
Green: Plexiglas #2108 or Matthews “Wild Mint” #46A-1A
Blue: Plexiglas #2050 or Matthews “Mosaic Blue #70A-1A
Purple: To Match Husky Purple or PMS #2597C
Violet: PMS #239C 2X

- B. All colors shall be submitted to the Owner for approval before fabrication.

PART 3 - EXECUTION

3.1 FABRICATION

- A. Shop Assembly: To the largest extent possible, all signs shall be fabricated off-site under shop conditions.
- B. Cutting, Routing and Machining: Cut all materials to provide smooth cut surfaces, exact in shape and dimension to the design specified. Ensure that rectangular shapes retain 90 degree angles at all corners and remove all traces of burr and slag from cut surfaces. All metal or hard plastic portions of sign shall have edges eased to remove sharp edges which are a cut hazard.
- C. Painting: Paint all colors in a climate and dust controlled environment. Ensure that no drips, runs or orange-peel is created due to poor workmanship or bad drying conditions. Prime all painted surfaces with a primer recommended by the paint manufacturer for the surface to be painted.
- D. Glue and Tape: Acrylic sheet and other light-weight materials may be glued with commercial grade mastic compatible with acrylic products. Do not allow any glue product come in contact with screen printed inks or paint. High-strength tape may be used in the assembly of the signs only if the assembly retains a mechanical means of attachment to relieve the shear forces caused by the weight of the materials involved. Such tape shall not be the sole source of structural support for the sign, except in the case of small wall plaques. Submit all structural uses of tape to the Architect for review and approval.

City of Seattle – Warren G. Magnuson Park
SECTION 10425 - SIGNAGE

- E. Cleaning: Clean all signs of handling marks, fingerprints, dust and debris before wrapping for shipment.
- F. Preparation for Delivery: Wrap and protect all signs with plastic or paper and use sufficient padding to prevent nicks damage to the sign faces during shipment.

3.2 INSTALLATION

- A. Shipping & Delivery: All signs shall be delivered to the site in good condition. Coordinate the delivery of the signs with the Owner and the General Contractor.
- B. Storage: Signs shall be stored in a location designated by the Owner. Signs not installed immediately shall be stored as directed by the Owner and their storage location made secure from theft or vandalism. Prepare a list of the stored signs and delivery copies to the Architect and the Owner.
- C. Sign Locations: All signs shall be custom fitted to existing field conditions. Verify the location of all signs with the Architect and notify the Architect of any conflict between proposed sign locations and switches, thermostats, doors, windows, or other architectural features. The location information in the Sign Schedule indicates the sign's approximate location in the building. For sign locations not indicated in the Sign Schedule, the Architect will provide site directions regarding location and may place numbered stickers in the building indicating final installation locations. Bid price shall recognize the possibility of the relocation of a sign from the location described in the Sign Schedule to another location of similar installation complexity. No addition cost will be allowed for such relocations.
- D. Anchorage: All signs shall be attached to walls and surfaces in the manner compatible with the substrata and using concealed anchorage suitable to the mounting situation. Contact the Architect if the existing condition is not suitable for either the sign or normal anchorage methods. All damage to walls during installation shall be repaired immediately to match adjacent wall conditions.
- E. Fit and Finish: All signs shall be installed plumb, square and at the proper level to a tolerance of 1/8" in five (5) feet. Patch all wall surfaces disturbed by the installation process and repair any damage caused.
- F. Coordination With Other Trades: Coordinate with other trades to ensure that the signs do not block the installation or operation of other equipment.
- G. Corrosion Prevention: Do not allow dissimilar metals to be installed in contact with each other without adequate electrolytic protection.
- H. Sign Removal: All existing signs being replaced by the new signs or within 12" of the new sign location shall be removed by the installer as part of the bid price.
- I. Painting & Patching: All existing signs which are specified for removal (or which duplicate the function of new signs) shall be removed and their mounting holes patched and

City of Seattle – Warren G. Magnuson Park
SECTION 10425 - SIGNAGE

painted. Unpainted portions of wall revealed by sign removal shall be painted to match adjacent wall color.

- J. Project Documents On Site: The installer shall be required to have a full set of bid documents (plans, specifications, schedule, addenda, & clarification documents) on site during any part of the installation.

3.3 PROTECTION

- A. Post-installation Protection: Protect all sign surface from damage if they are in a construction area which is still active or until they are accepted by the Owner. Signs which cannot be adequately protected in such area should not be installed and their installation scheduled for a later date when the cessation of construction activity make their location safe.
- B. Types of Protection: Signs shall be covered with dust-proof plastic or paper wrapping and all corners padded from impact damage if they remain in an active construction area.

END OF SECTION

A01 - Large Vehicular Directional

Main version of vehicular directional sign; use on all major roadways to direct visitors to main parts of the park.

Color of background is based on location:
Burgundy for Historical District and
Teal for Shoreline.

A02 - Small Vehicular Directional

Smaller version of vehicular directional sign; use on all major roadways to direct visitors to main parts of the park, but where viewing distance is shorter due to trees, buildings, or shorter distance between signs.

Color of background is based on location:
• Burgundy for signs located in the vicinity of the Historical District
• Teal for signs located in the vicinity of the Shoreline and natural areas of the park.

A03 - Pedestrian Directional, Tall

Used for directing along pedestrian paths where destinations are not visible to the visitor. Locate at intersections where possible to maximize the number of pointers per pole.

Color of background is based on location:
• Burgundy for destinations in Historical District
• Teal for destinations in Shoreline
• Red for Emergency Services

A04 - Pedestrian Directional, Short

Used for directing along pedestrian paths where sign needs to be less obtrusive in the natural environment, such as along nature trails.

Color of background is based on location:
• Burgundy for destinations in Historical District
• Teal for destinations in

**A05 - Accessible Route Advice Sign
A06 - Accessible Route Warning Sign**

These signs are used along accessible routes to:

A05: Mark entrances to accessible ramps or entrances which are not easily visible from the normal building approach
A06: Mark paths adjoining the accessible route which are steeper than 1:10 and may present a wheelchair or ambulatory hazard.

The color of the upper portion of each sign helps signal its main function:

A05: Accessible Blue to signal access
A06: Safety Yellow to signal warning

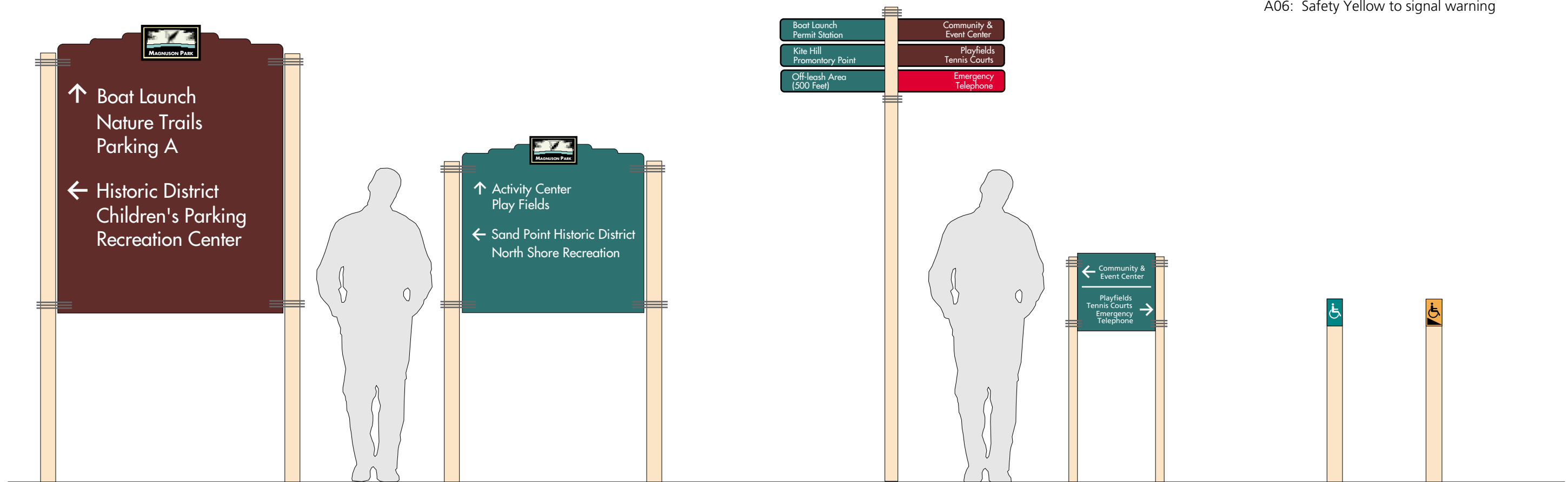

A01
Large Vehicular
Directional

A02
Small Vehicular
Directional

A03
Pedestrian
Directional,
Tall

A04
Pedestrian
Directional,
Short

A05
Accessible
Route
Advice Sign

A06
Accessible
Route
Warning Sign

B01 - Large Destination I.D.

Used to mark the general area or key entrance area to major park functions. Destinations thus designated must receive significant public traffic or be a key functional area of the park. These destinations will always be listed on the A01, A02, A03 & A04 signs.

The list of suggested behavior is a "friendly" version of the basic park rules and the language should be brief and positive.

- Color of background:
- Burgundy for Historical District
 - Teal for Shoreline

B01 - Variataions by Destination

The following destinations are currently designated to receive the B01 sign type:

- Kite Hill
- Dog Off-Leash Area
- Boat Launch
- Promontory Point
- Nature Trails

The symbol attached to each sign illustrates the spirit of the activity which occurs here and should be simple and fun in its rendering.

B02 - Special Activity I.D.

Used to mark smaller activities and sub-categories of major activities. Sign panel size may vary with text.

The symbol attached to each sign illustrates the spirit of the activity which occurs here and should be simple and fun in its rendering.

- Color of background:
- Burgundy for Historical District
 - Teal for Shoreline

B03 - Special Activity I.D., Wall Mount

Used to mark smaller activities and sub-categories of major activities where structure existing upon which to mount the sign.

No illustration is used.

- Color of background:
- Burgundy for Historical District
 - Teal for Shoreline

B04 - Large Building I.D.

This sign is used in front of park building which contain tenant or park functions whose name must be marked from the road.

The sign structure should remain neutral park colors, while the park logo and region colors should be used.

This sign type may need to list a group of park functions instead of simply one name, but if park functions are mixed with a group of tenants in the same building, a separate T01 sign should be used. If only one tenant is present in addition to park functions, the tenant name may appear on a separate B04.

B05 - Small Building I.D.

Smaller version of B04 which should be used where the viewing distance is smaller and/or the scale of the surrounding landscape would not accept the larger B04.

This sign type relates to T01 - Tenant Directory, except that the tenant directory sign indicates an address or building number at the top of the series of tenant I.D. panels.

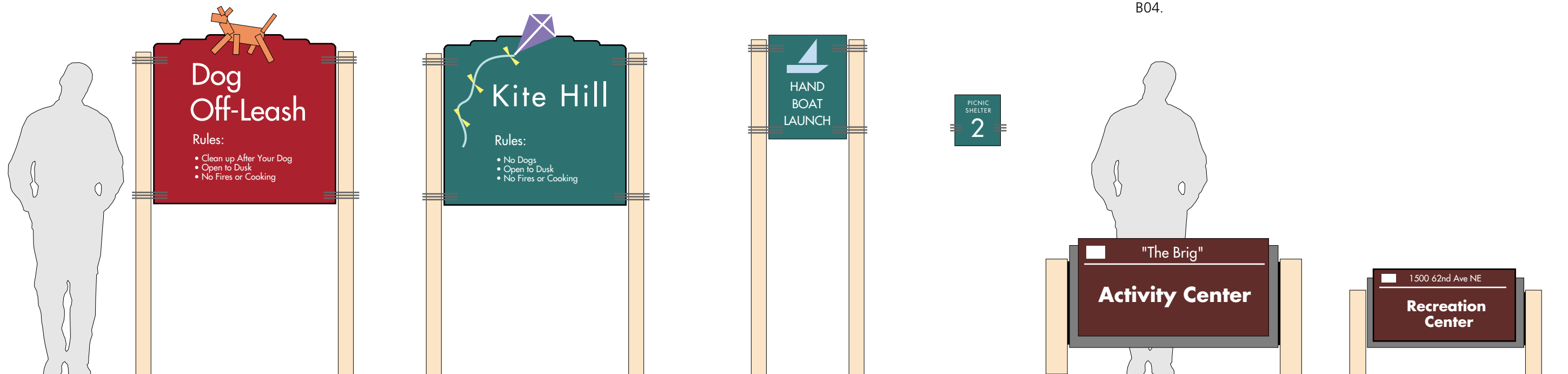

B01
Large,
Destination
Identification

B01 (Variation)
Large,
Destination
Identification

B02
Special Activity
Identification

B03
Special Activity
Identification,
Wall Mount

B04
Large
Building
Identification

B05
Small
Building
Identification

B06 - Historic Building Numbers

This design is used to restore the original building numbering from the Naval Base which remains on some park buildings. It is meant to replace or fill in missing numbers which were part of the original numbering scheme for the base.

It may be used in addition to other I.D. signs which provide specific functional names for services or tenants in the park. It is located in the traditional place for each building according to historic documents, or adjusted slightly for better sightlines.

Color should be black or metal finish to fit with the style of the building in questions, but all such sign type should use the same typeface.

30

B07 - Typical Address Numbers

All buildings in the park should have address numbers if they are situated on a named or numbered street.

They serve as mail delivery or way-finding aids to confirm any exterior signage which may exist.

Color should be black or metal finish to fit with the style of the building in questions, but all such sign type should use the same typeface.

6208

B08 - Parking Lot I.D.

Each parking area in the park should be marked at its entrance with this sign giving the main parking designation.

Sign is two-sided and may need to be repeated on some large lots on lots with unusual proportions.



B09 - Boat Launch Sign

This unique sign is used to control the vehicular traffic according to whether they are boats on trailers or empty trailer. Sign is one-sided to face incoming traffic. Don't post other signs on these poles.



B10 - Restroom Door Sign

Use to mark ADA-required sign on exterior door or adjacent wall for public restrooms.

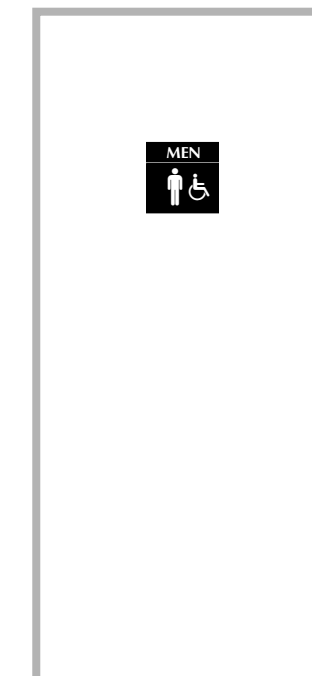

B11 - Projecting Restroom Sign

This sign is used to mark one or more restrooms by projecting from the upper wall on or near to the centerline of the restroom doors.

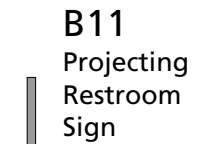

B06
Historic Building Numbers

B07
Typical Address Numbers

B08
Parking Lot Identification Sign

B09
Boat Launch Lane Sign

B10
Restroom Door Sign

C01 - Campus Directory Map, Large

Use at major entrances and areas of large public traffic to post a map of the entire park area, at an appropriate scale.

Map should contain all park destinations, services, functions, ADA accesses, emergency functions, and uses text and symbols for legibility.

Below the map is a zone for brochure racks (for paper park maps) and a place for incidental park rules and other text.

C02 - Campus Directory Map, Small

Similar to C01, except 3/4 scale.

Use this size in the Historic District or other areas, such as the Nature Trails where a larger sign would be intrusive.

N01 - Interpretive Sign

Used to contain historic or environmental interpretive information, photos, and diagrams.

This sign is a first

R01 & R02 - Stop & Yield Signs

These are standard DOT traffic signs on a custom pole.

They should be used to enhance the park's traffic and safety format as being typical of a portion of the city.

R03 - Custom street Sign

Use on all streets in the park which use a name which appears on the park map.

This will enhance the wayfinding experience when used with the new address numbers in Sign Type B07.

R04 - Park Rules & Regulations Sign

Custom pole and support structure to hold standard park rules and regulations in new graphic format, but which meet City legal requirements.

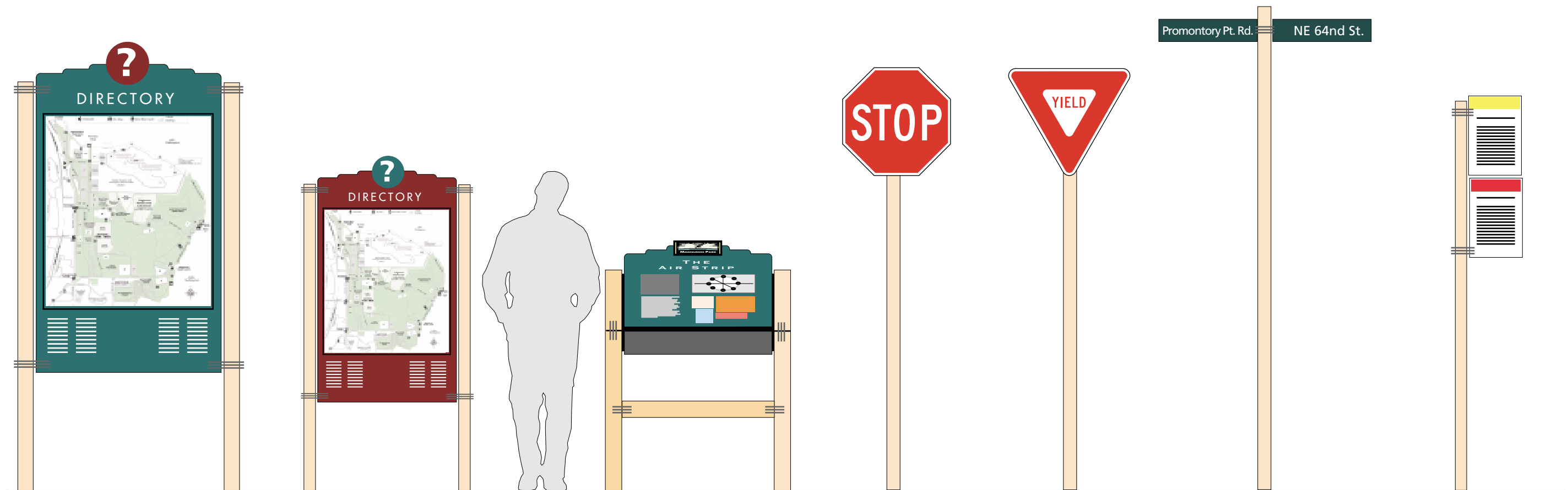

C01
Campus
Directory Map,
Large

C02
Campus
Directory Map,
Small

N01
Interpretive
Sign

R01
Standard
Stop
Sign

R02
Standard
Yield
Sign

R03
Custom
Street
Sign

R04
Park Rules &
Regulations
Sign

T01 - Tenant Directory @ Group Entrance

Used to show which tenants occupy a particular building when the street approach and the entrance to each tenant are not close to each other. Usually occurs where visible from the road and near and entrance to parking or other vehicular area of access to the tenant building.

If there is not room in the vicinity of the tenant door for a B04 or B05 sign, the T01 can provide a listing of a group of tenants.

Colors and logos for each tenant are preferred. The top of the sign marks the building number or address number associated with the tenant's location.

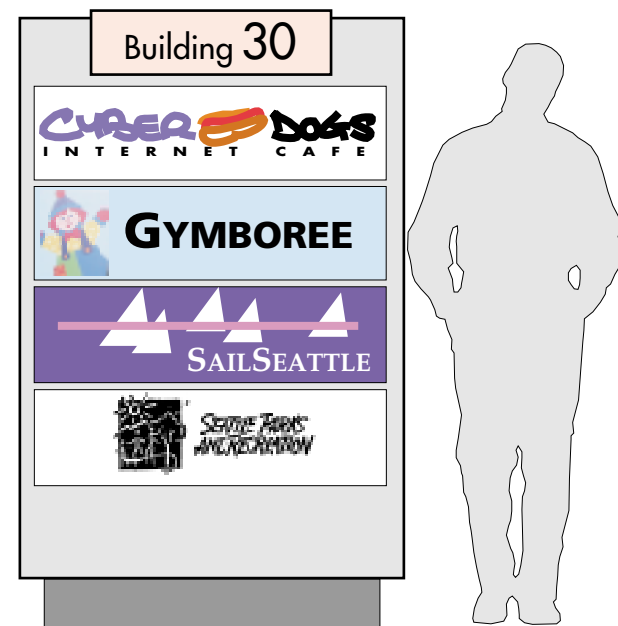

T01
Tenant Directory
@ Group Entrance

T02 - Temporary Tenant Banner

This sign type regulates the size and design of temporary banners used by tenants under the following circumstances:

- Mark their business until permanent signs are installed
- Announce an event of specific duration
- NOT to be used for sales, prices lists, or retail offers
- Must be removed when agreed with Park.
- May vary in size, but location is restricted.



T02
Temporary
Tenant
Banner

T03 - Tenant Changeable I.D.

This sign type offers a way to mark multiple tenants who are reached via a single door or entrance area.

Similar in function to the T01, except is smaller and wall-mounted.

Modular construction allows for additional tenants and address or building number on the top confirms the visitor is in the correct place.

The number of tenants will determine the height of each strip and the size of lettering used, since available wall space will govern overall size.



T03
Tenant Changeable
Identification
Sign

T04 - Tenant Identification Sign

This is the largest building-mounted variety of tenant sign allowed in the signage standards.

The idea is to mark the extent of the main door and entrance windows or similar architectural feature of the tenant building. Review of the specific design is required by the Park.

Tenant logos and colors are preferred.

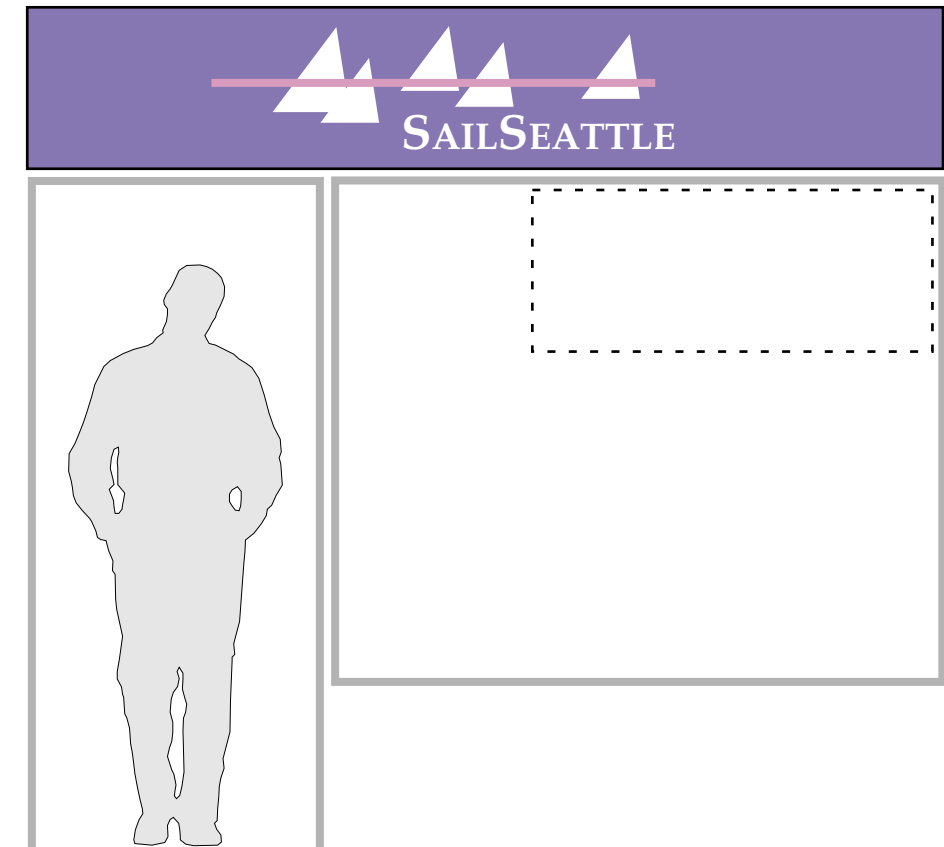

T04
Tenant
Identification
Sign

T05 - Tenant Interior Promotion Sign

The tenant may post any time of interior window sign of either lighted or non-lighted variety as long as the overall area of the sign does not exceed 20% of the contiguous window area.

Example: A window measuring 4'x5' has 20 sf of area, so the sign must not exceed 4 sf.

T05
Tenant Interior
Promotion
Sign

T06 - Temporary Event Totem

When events occur in the Park, event organizers may post a 20"x30" sign of their own design & creation on this "posting sign", which is located at key roads and intersections to address vehicular traffic attending the events.

At the end of the event, all signs must be removed. No free-standing "A-board" signs are allowed and will be removed.

When empty, the Event Totem is designed to resemble an open lattice metal sculpture reflecting the Deco period of Naval Base history.

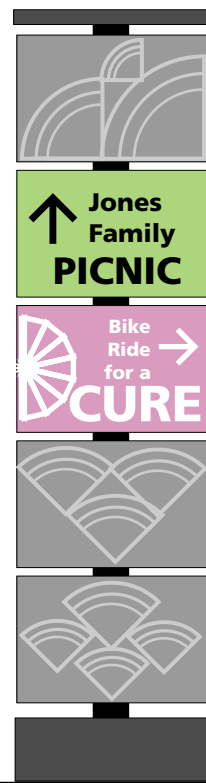

T06
Temporary Event
Totem
Sign

T07 - Banner Trellis @ Park Perimeter

As a way of organizing all the banner placement which are requested for events at the Park, from 3-6 of the T06 Event Totems are grouped together to form a standardized "posting" area at various points around the campus perimeter and near traffic points. Banners are limited in proportion to fit the grid of the Trellis, but may contain event logos, dates, and sponsor information.

At the end of the event, all banners must be removed. No other event banner posting will be allowed.

When empty, the Banner Trellis is designed to resemble an open lattice metal sculpture reflecting the Deco period of Naval Base history.

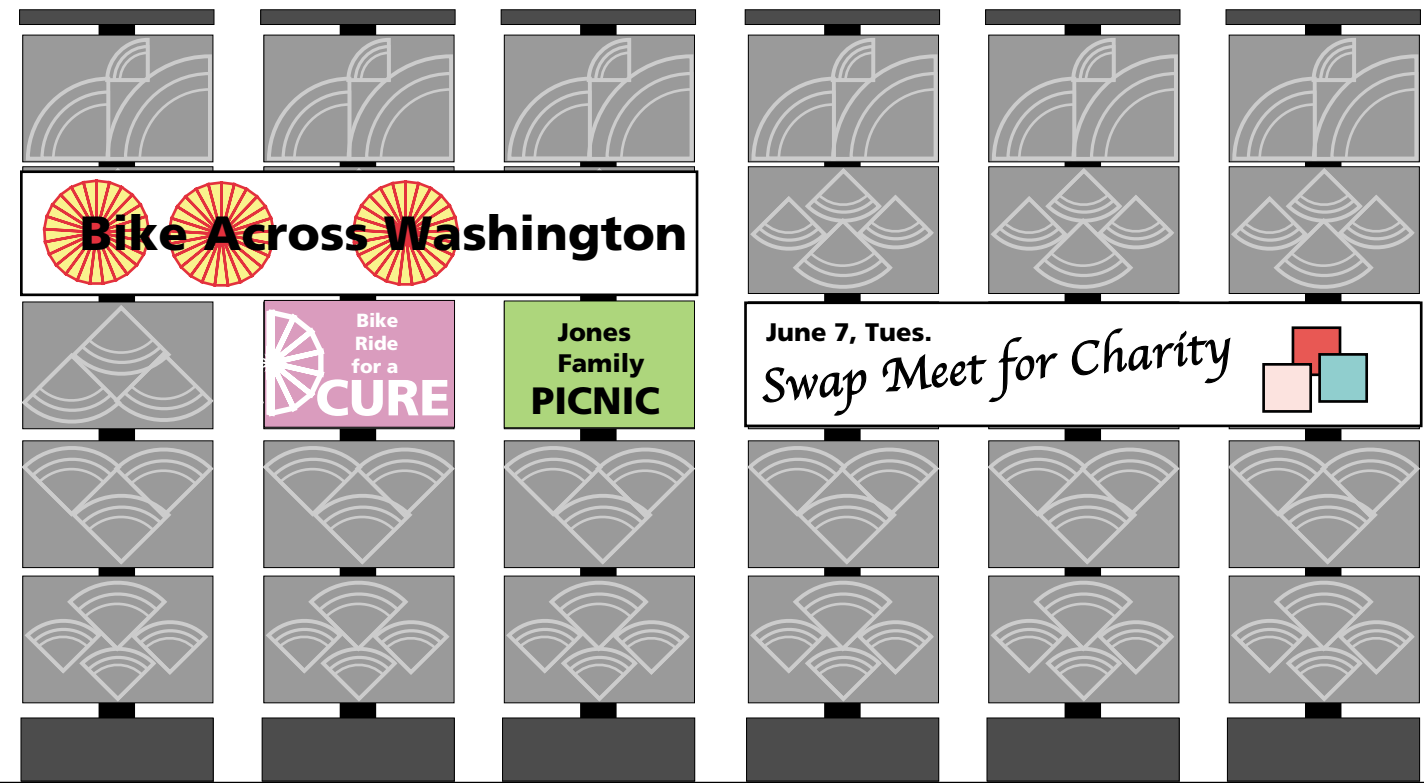
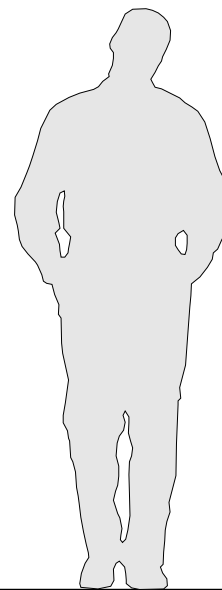

T07
Banner Trellis
@ Park Perimeter

A01 - Large Vehicular Directional

Dimensions:
 A = 52" (panel width) B = 65" (panel ht.)
 C = 100" (post ht.) D = 104" (overall ht.)
 E = 35" (clearance) F = 9" (margin @ arrow)
 G = 3" (min. margin) H = 4.25" (arrow ht.)
 J = 6" (line-to-line) K = 10" (parag. gap)

Cap Ht. = 3.5"
 Typeface = Futura Regular
 Style = Caps & lower case
 Type Color = White
 Panel Color = P1 or P2
 Post Color = P3
 Park Logo = 8"x12"

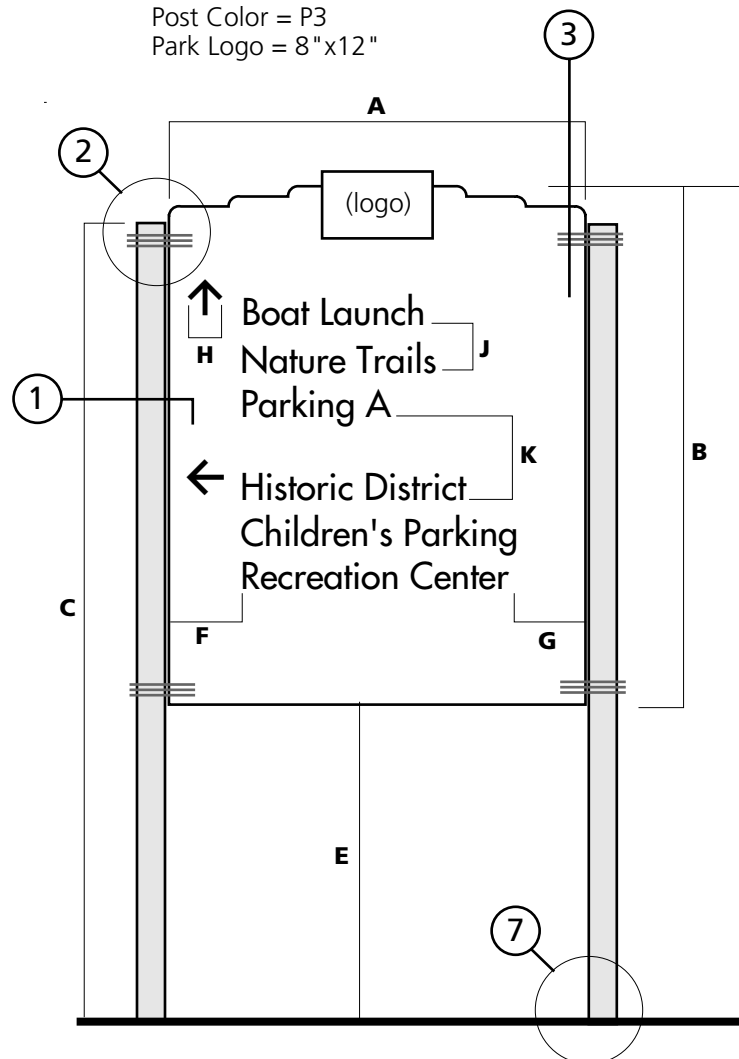

A01
Large Vehicular Directional

A02 - Small Vehicular Directional

Dimensions:
 A = 42" B = 40"
 C = 75" D = 78"
 E = 35" F = 6"
 G = 2" Min. H = 2.75"
 J = 3.5" K = 6.5"

Cap Ht. = 2"
 Typeface = Futura Regular
 Style = Caps & lower case
 Type Color = White
 Panel Color = P1 or P2
 Post Color = P3
 Park Logo = 6"x10"

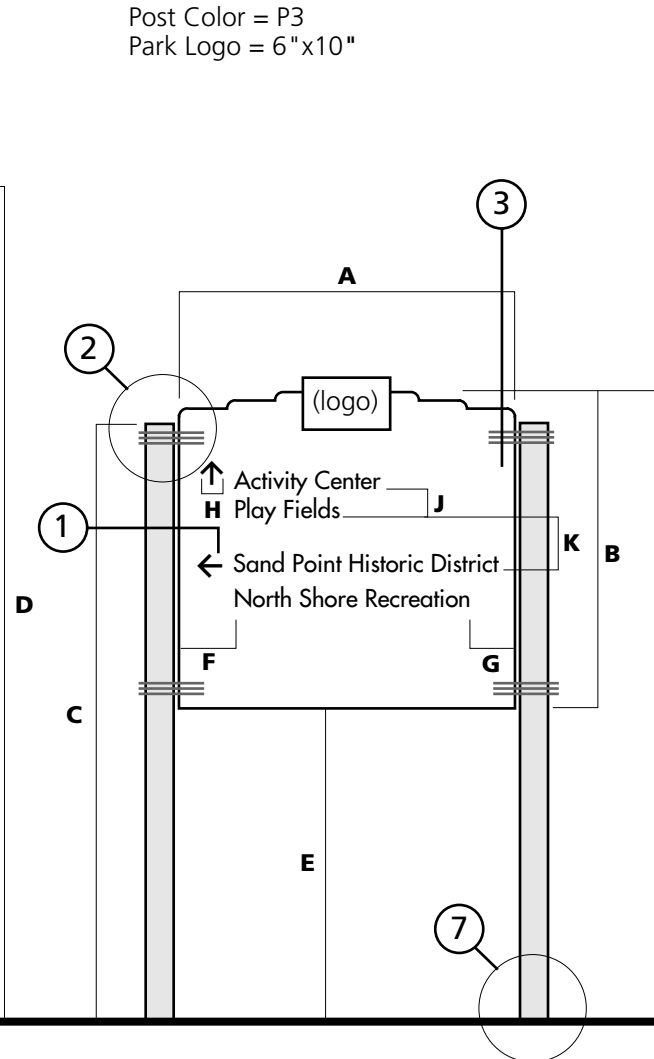

A02
Small Vehicular Directional

A03 - Pedestrian Directional, Tall

Dimensions:
 A = 24" B = 5"
 C = 110" D = 1"
 E = 90" Min. F = 3"
 J = 2.25"

Cap Ht. = 1.25"
 Typeface = Futura Regular
 Style = Caps & lower case
 Type Color = White
 Panel Color = P1 or P2
 Post Color = P3

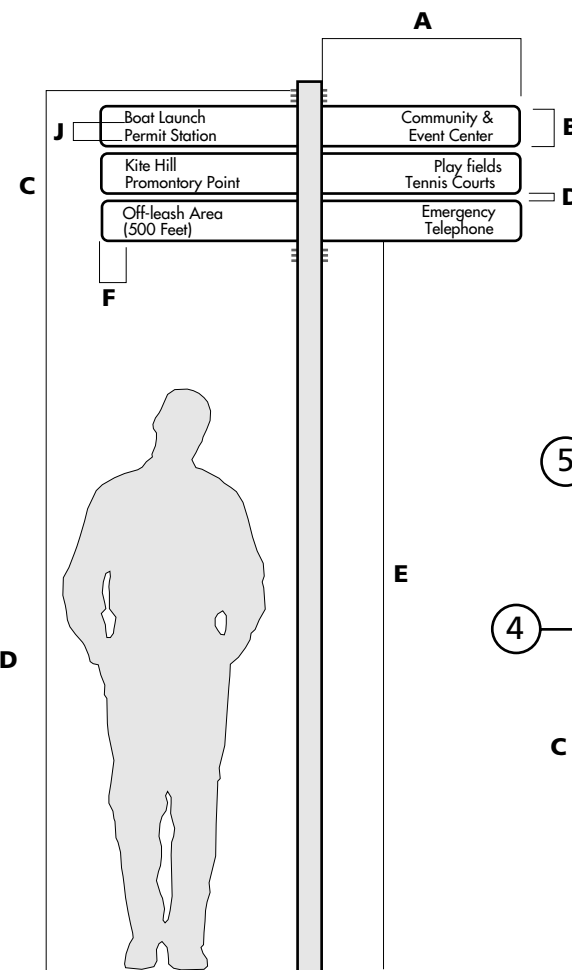

A03
Pedestrian Directional, Tall

A04 - Ped. Dir., Short

Dimensions:
 A = 18" B = 18"
 C = 52" D = 54"
 E = 36" F = 4.5"
 G = 1.25" Min. H = 2.5"
 J = 1.25" K = 6.5"

Cap Ht. = 1.25"
 Typeface = Futura Regular
 Style = Caps & lower case
 Type Color = White
 Panel Color = P1 or P2
 Post Color = P3

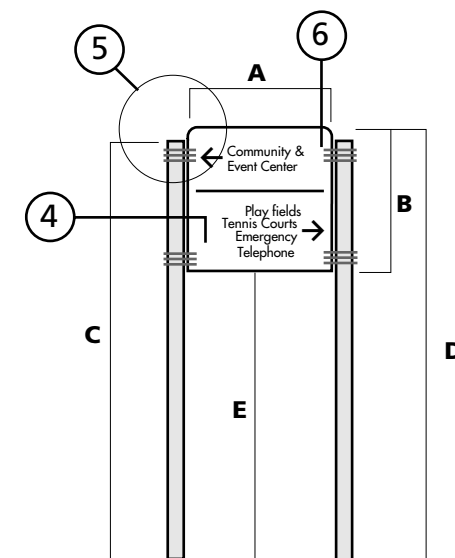

A04
Pedestrian Directional, Short

A05 - Accessible Route Advice Sign

Dimensions:
 A = 3.5" B = 6.25"
 C = 42"

Symbol Ht. = 3.5"
 Symbol Color = White
 Panel Color = P4 (Blue)
 Post Color = P3

A06 - Accessible Route Warning Sign

Dimensions:
 A = 3.5" B = 6.25"
 C = 42"

Symbol Ht. = 3.5"
 Symbol Color = White
 Panel Color = P5 (Yellow)
 Post Color = P3

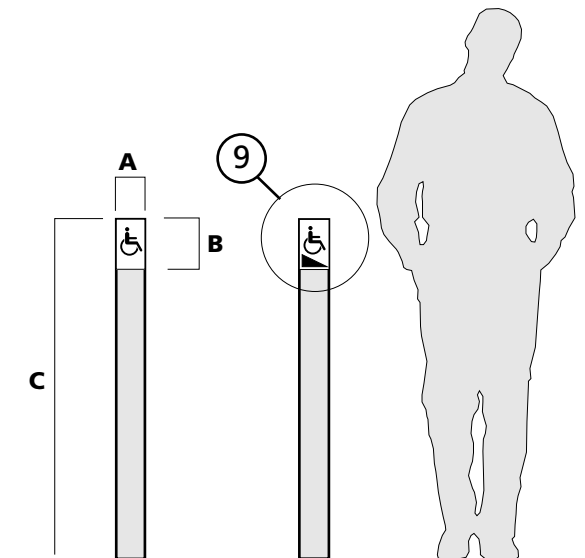

A05
Accessible Route Advice Sign

A06
Accessible Route Warning Sign

B01 - Large Destination I.D.

Dimensions:
A = 42" (panel width) B = 40" (panel ht.)
C = 75" (post ht.) D = 78" (overall ht.)
E = 35" (clearance) F = 2" (min. margin)
G = 2" (min. margin)
J = 8" (line-to-line)

Cap Ht. = 5" & 1.5"
Typeface = Futura Regular
Style = Caps & lower case
Type Color = White
Panel Color = P1 or P2
Post Color = P3

Dog Logo = 12"x15" outside dimensions

B01 - Variations by Destination

Each destination will have a different name, set of rules, and activity illustration. Artwork provided by Owner.

B02 - Special Activity I.D.

Dimensions:
A = 18"
B = 24"
C = 78"
D = 80"
E = 54"
Panel Radius: 3/4"

Center all text & symbol.

Cap Ht. = 2.5"
Typeface = Futura Regular
Style = Caps & lower case
Type Color = White
Panel Color = P1 or P2
Post Color = P3

B03 - Special Activity I.D., Wall Mount

Dimensions:
A = 10"
B = 12"
E = 60"

Center all text & symbol.

Cap Ht. = 1.5"
Number Ht. = 4"
Typeface = Futura Regular
Style = Caps & lower case
Type Color = White
Panel Color = P1 or P2

B04 - Large Building I.D.

Dimensions:
A = 24"
B = 48"
C = 28"
D = 30"
E = 6"

Tenant Panel:
AA = 22"
BB = 44"

All tenant sign designs and colors must be approved by Owner.

Panel Color = P1 or P2
Post Color = P3

Construction:
Post: 4" sq. alum. tube
Sign Body: 4" deep alum. frame box w/ 1" tube internal framing
Reveal: 1" wide channel pair to allow joining post & body.
Sign Face: 1/4" alum./neoprene composite panel w/ bend at top & 2" overlap on body, similar to existing X01 sign construction.

B05 - Small Building I.D.

Dimensions:
All dimension are 75% of the B04 dimensions, except:
Clearance E = 6".

All tenant sign designs and colors must be approved by Owner.

Panel Color = P1 or P2
Post Color = P3

Construction:
Post: 4" sq. alum. tube
Sign Body: 4" deep alum. frame box w/ 1" tube internal framing
Reveal: 1" wide channel pair to allow joining post & body.
Sign Face: 1/4" alum./neoprene composite panel w/ bend at top & 2" overlap on body, similar to existing X01 sign construction.

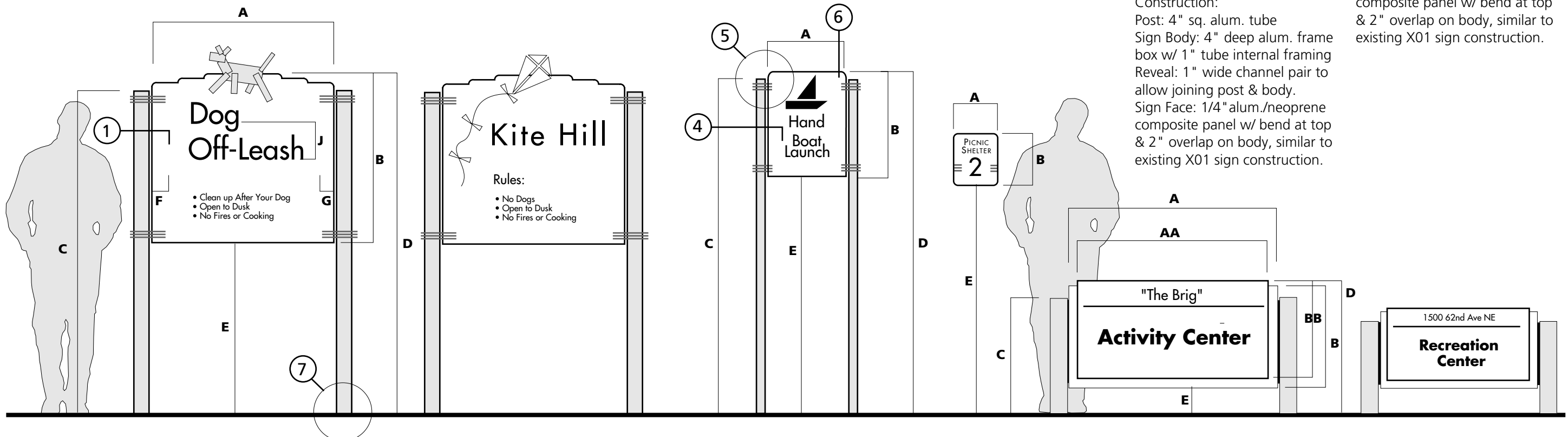

B01
Large,
Destination
Identification

B01 (Variation)
Large,
Destination
Identification

B02
Special Activity
Identification

B03
Special Activity
Identification,
Wall Mount

B04
Large
Building
Identification

B05
Small
Building
Identification

B06 - Historic Building Numbers

Dimensions:
Number Ht.: 10", 12", or 15"

Placement of numbers to be determined in the field, but generally should duplicate the historic location the numbers occupied on each building.

B07 - Typical Address Numbers

Dimensions:
Number Ht.: 4", 4", or 8"

Placement of numbers to be determined in the field, but generally should mark the main entrance to each building or present themselves to a view from the street.

B08 - Parking Lot I.D.

Dimensions:
A = 18" B = 24"
C = 125" D = 127"
Panel Radius: 3/4"

B09 - Boat Launch Sign

Dimensions:
A = 18" B = 36"
C = 125" D = 127"
Panel Radius: 3/4"

B10 - Restroom Door Sign

Dimensions:
A = 9" B = 9"
C = 60"

Locate sign on door or strike side of door, 3" from frame.

Text = 1.25" Futura Regular, caps & lower case
Men/Women Symbol = 4.5"
Access Symbol = 3.5"

B11 - Projecting Restroom Sign

Dimensions:
A = 12" B = 12"
E = 90"

Locate sign on door or strike side of door, 3" from frame.

Text = 1.5" Futura Regular, caps & lower case
Men/Women Symbol = 6.25"
Access Symbol = 4.5"

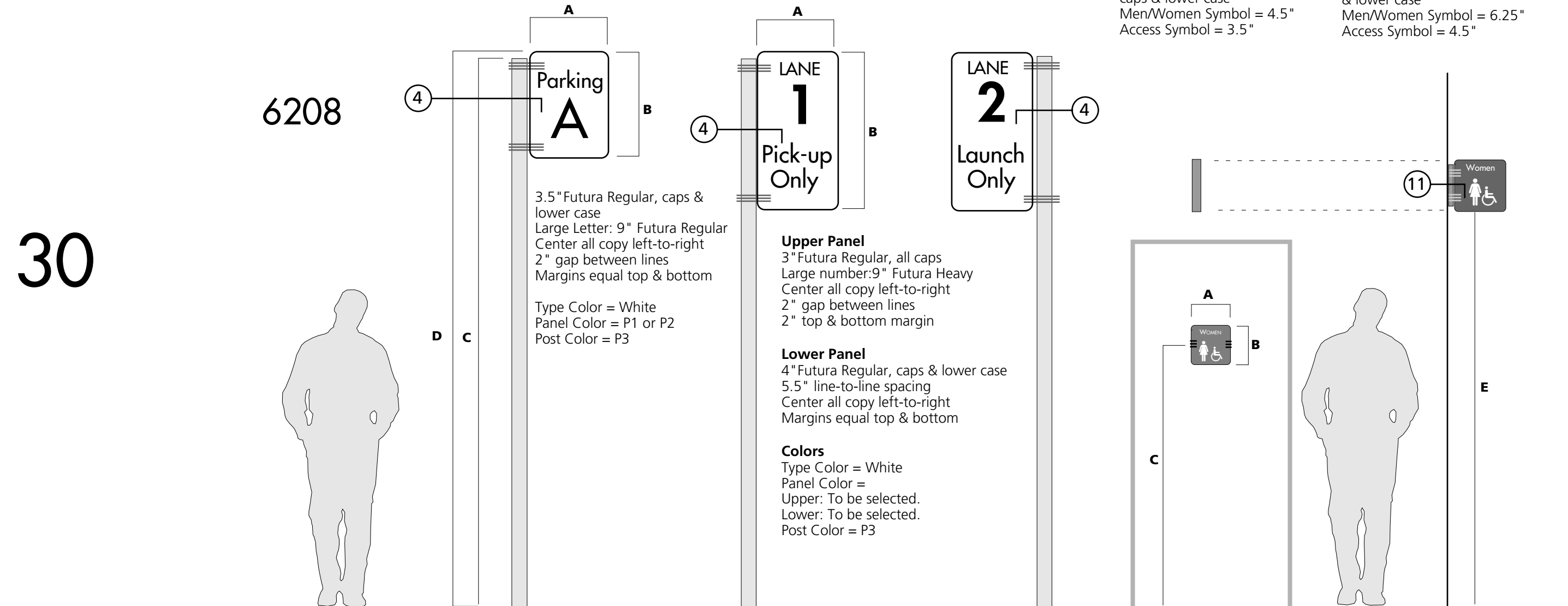

B06
Historic
Building
Numbers

B07
Typical
Address
Numbers

B08
Parking Lot
Identification
Sign

B09
Boat Launch
Lane Sign

B10
Restroom
Door
Sign

B11
Projecting
Restroom
Sign

12/22/04

C01 - Campus Directory Map, Large

Dimensions:
A = 42" (panel width) B = 70" (panel ht.)
C = 93" (post ht.) D = 96" (overall ht.)
E = 26" (clearance)

Sign Panel:
Title = 2.75" Futura Regular, all caps
Type Color = White
Bottom Text Paragraphs: To be determined
Info Symbol = 6.5" symbol inside 9.75" circle

Map Panel:
Size = 38" x 44"

C02 - Campus Directory Map, Small

Dimensions:
A = 31"
B = 52"
C = 70"
D = 72"
E = 20"

Sign Panel:
Title = 1.75" Futura Regular, all caps
Type Color = White
Bottom Text Paragraphs: To be determined
Info Symbol = 4.75" symbol inside 7.25" circle

Map Panel:
Size = 29" x 33"

N01 - Interpretive Sign

Dimensions:
A = 33"
B = 28"
C = 36"
D = 54"
E = 18"

Sign Panel:
Title = To be determined.
Logo =

Map Panel:
Size = 28" x 18"

R01 & R02 - Stop & Yield Signs

Dimensions and placement:

Per MUTCD specifications and City of Seattle Ordinances.

R03 - Custom Street Sign

Dimensions:
A = 22"
B = 5"
D = 110"

Text: Futura
2.35" cap & lower case
1.75" cap & lower case

R04 - Park Rules & Regulations Sign

Dimensions:
Typical Reg. Panel:
A = 12"
B = 18"

Overall Dimensions:
C = 88"
D = 89"

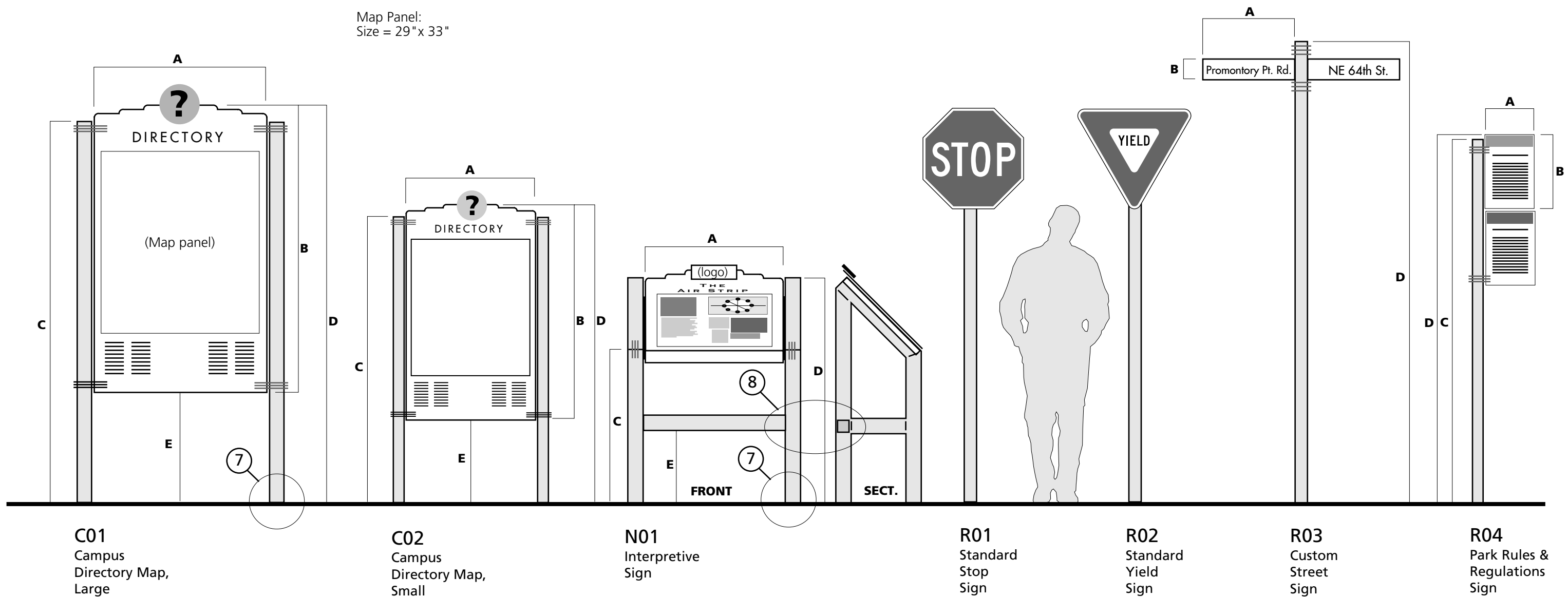

12/22/04

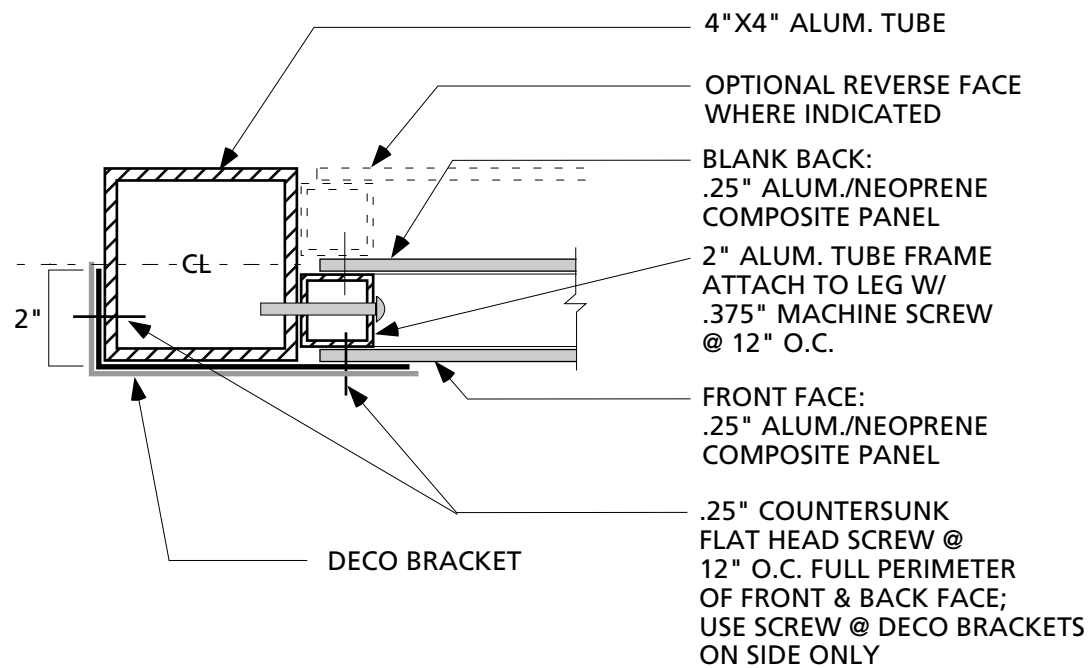

1 SECTION @ Leg
3" = 1'-0"

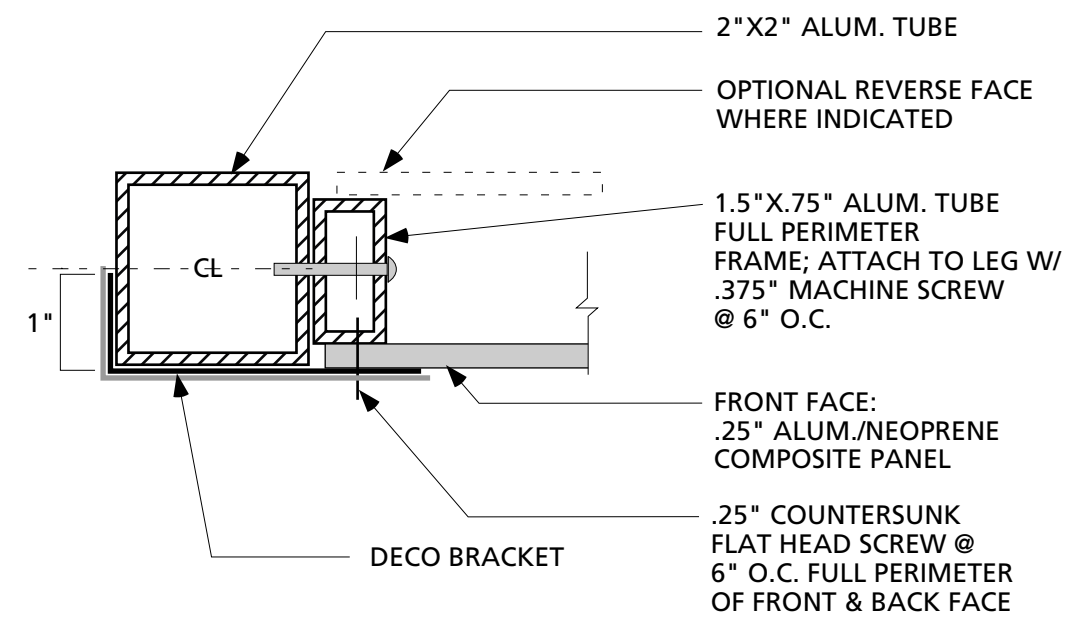

4 SECTION @ Leg
6" = 1'-0"

NOTE: DETAIL 4 SIMILAR ON SIGN TYPES: A04 & B02

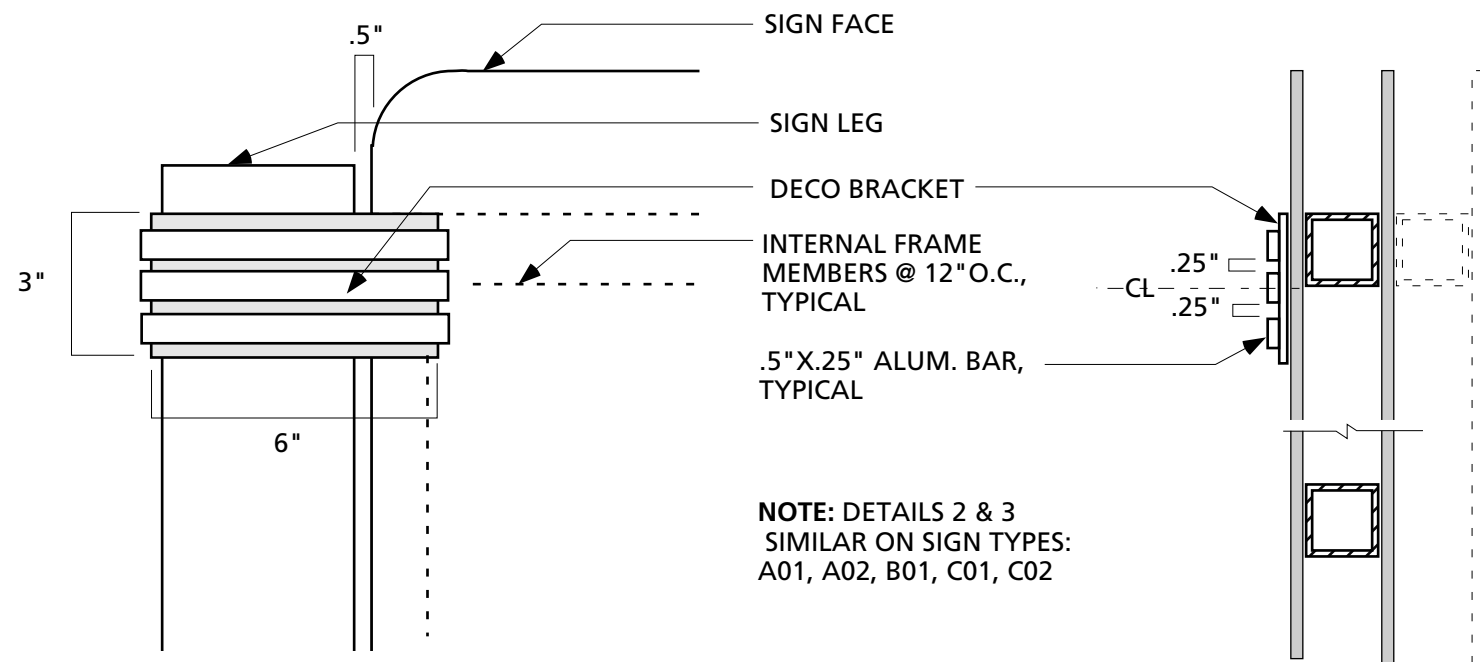

2 ELEVATION @ Deco Bracket
3" = 1'-0"

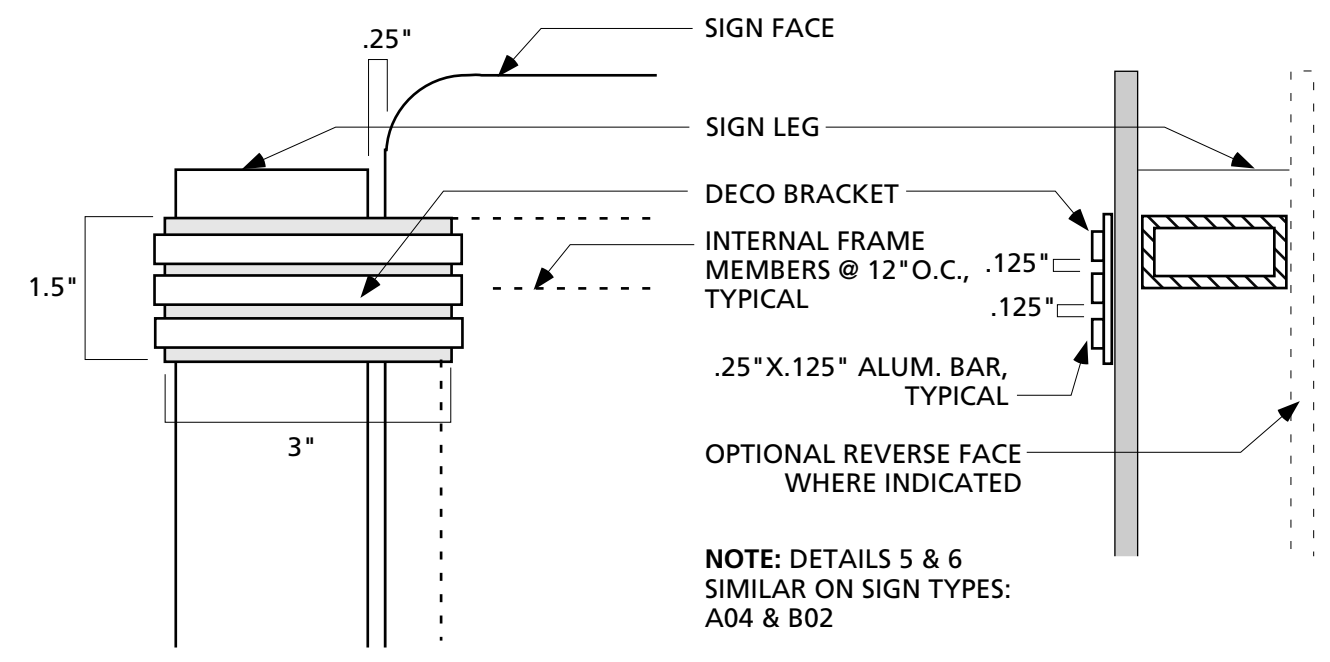

5 ELEVATION @ Deco Bracket
6" = 1'-0"

3 SECTION @ Deco Bracket
3" = 1'-0"

6 SECTION @ Deco Bracket
6" = 1'-0"

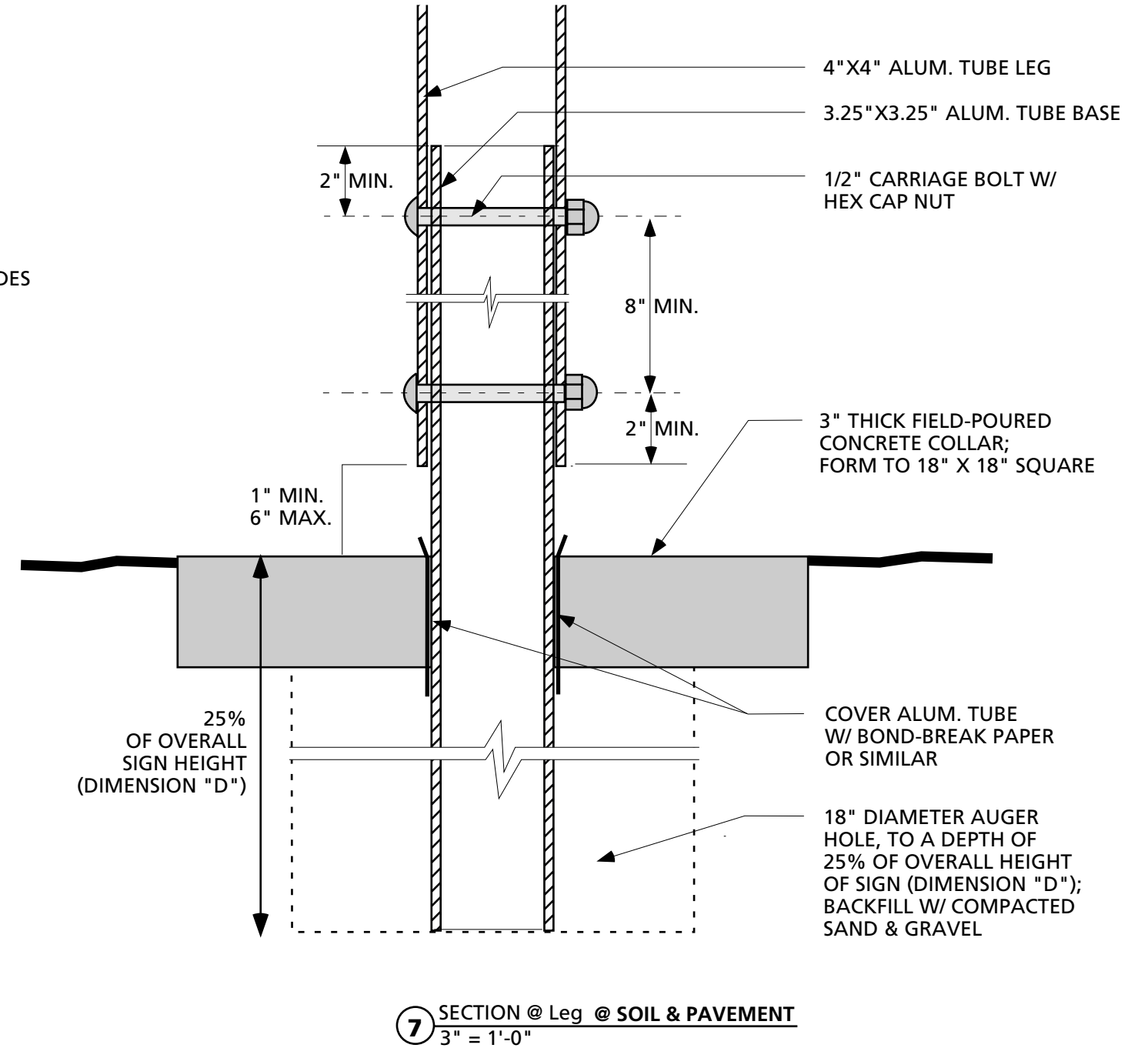
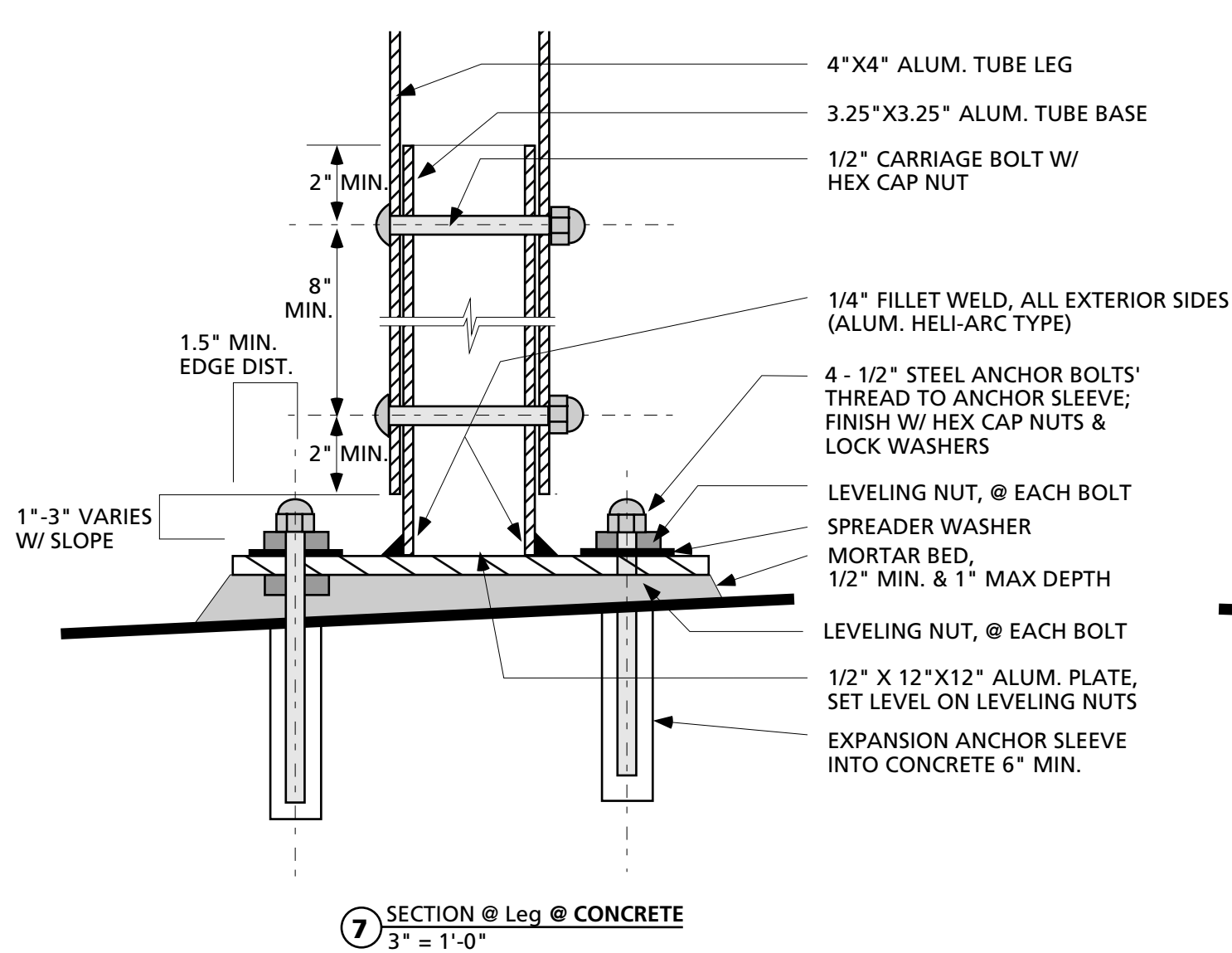

12/22/04

1571 Thorndyke Road
Port Ludlow, WA 98365
Tel (360) 437-9555
Fax (360) 437-9538
Email: kbd@olympus.net

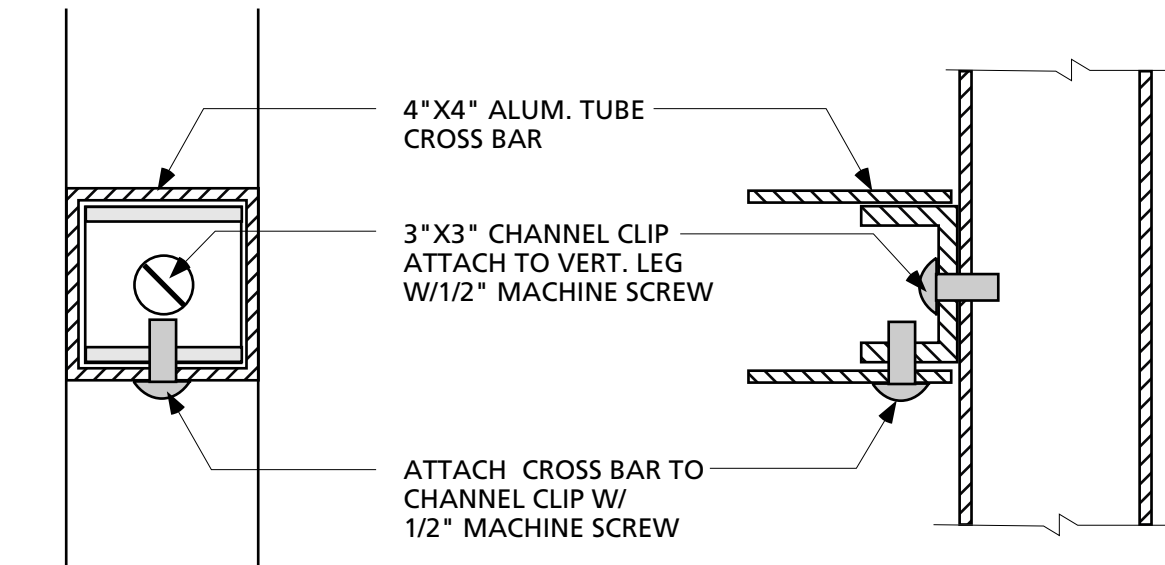

8 SECTION @ Cross Bar
3" = 1'-0"

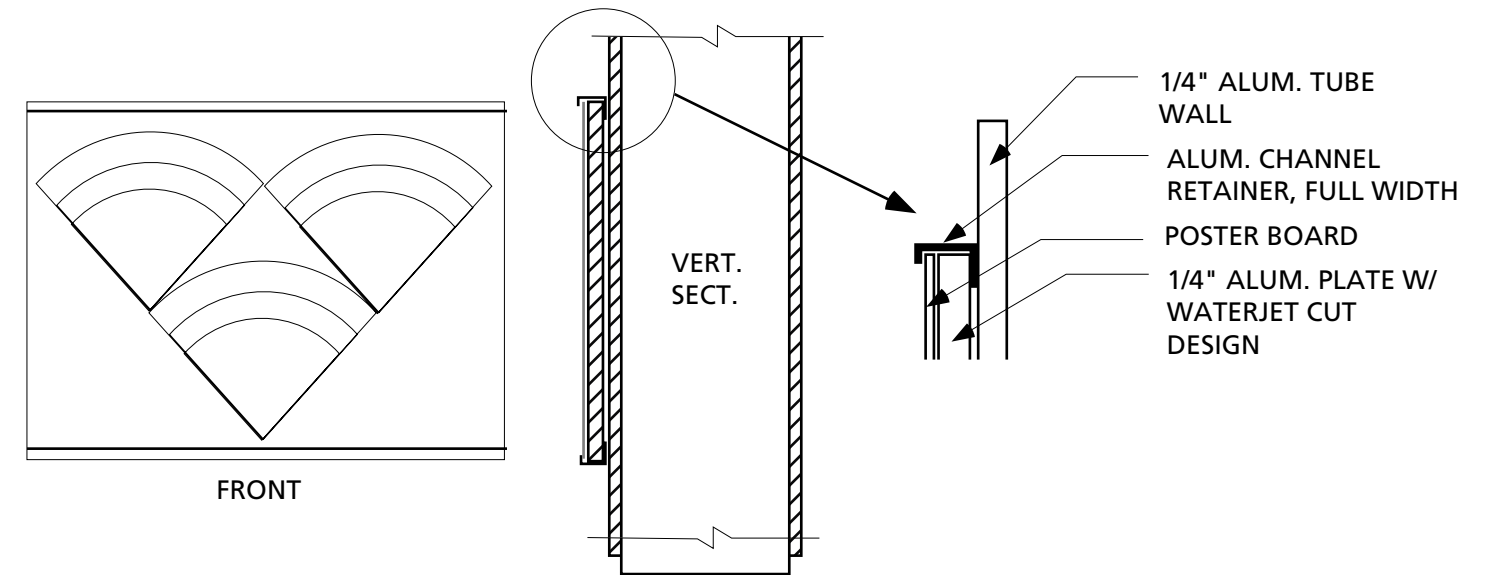

10 SECTION @ T06 Poster Module
1.5" = 1'-0"

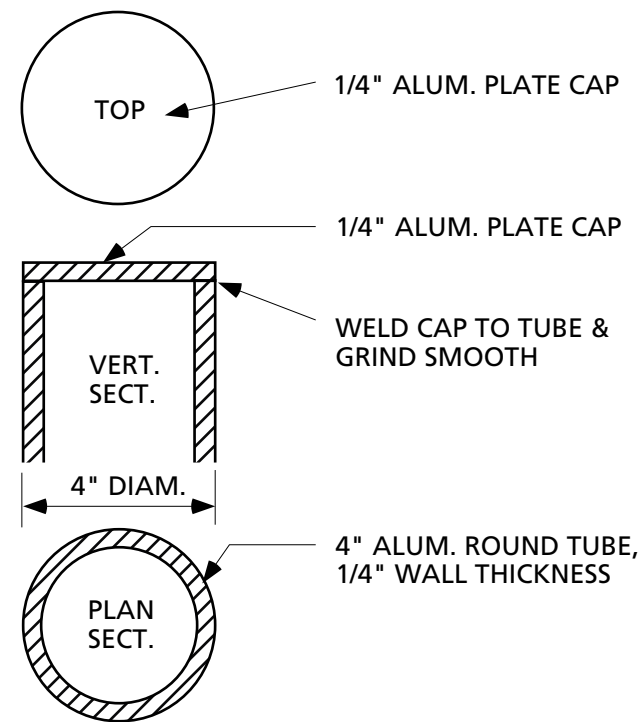

9 SECTION @ Round Tube
3" = 1'-0"

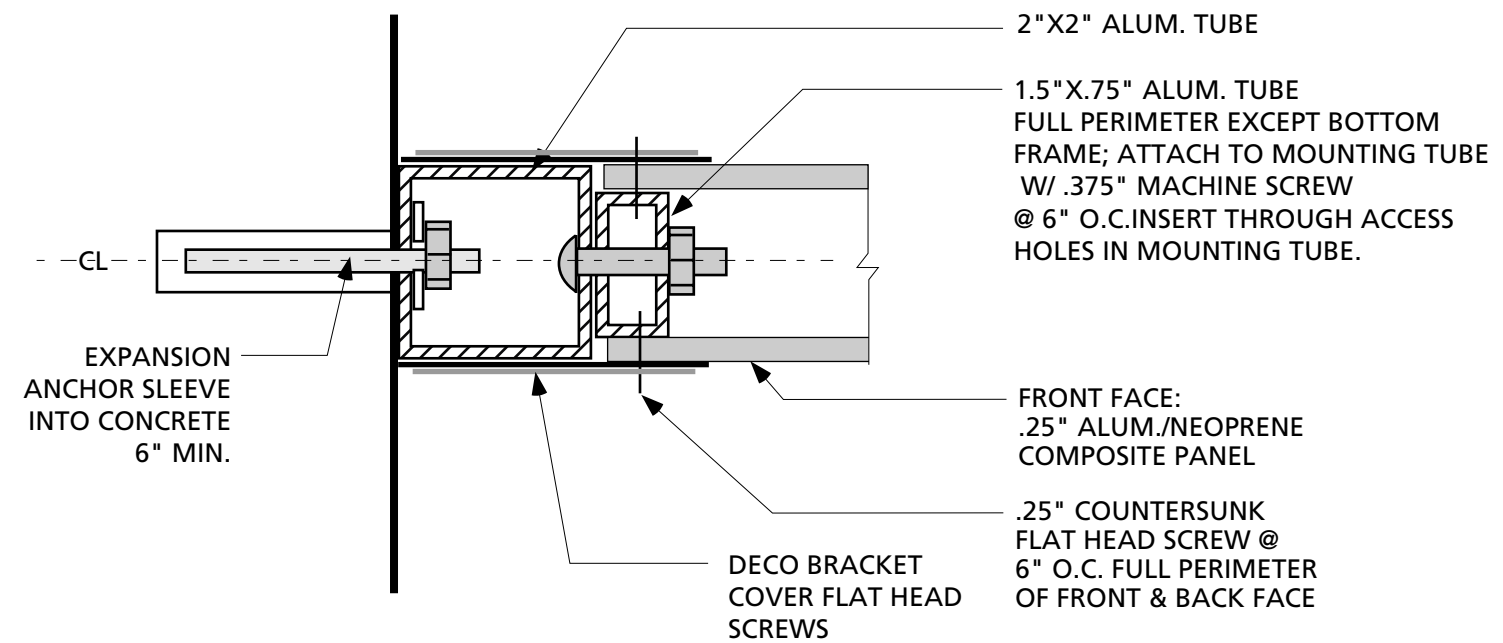

11 SECTION @ Restroom Sign
6" = 1'-0"

12/22/04

1571 Thorndyke Road
Port Ludlow, WA 98365
Tel (360) 437-9555
Fax (360) 437-9538
Email: kbd@olympus.net

T01 - Tenant Directory @ Group Entrance

Dimensions:

A = 48" B = 70"
F = 3" E = 6"

AA = 12" BB = 44"
AAA = 8" BBB = 30"

Building Title:
Typeface = 3" Futura Regular,
caps & lower case
Type Color = Black
Panel Color = P3

Tenant Panels:
To be determined.

T03 - Tenant Changeable I.D.

Dimensions:

A = 36" B = 24" (varies)
E = 36" (min.)

AA = 32" BB = 10"
AAA = 32" BBB = 5"

Building Title:
Typeface = 2" Futura Regular,
caps & lower case
Type Color = Black
Panel Color = P3

Tenant Panels:
To be determined.

T04 - Tenant Identification Sign

The size, materials, and location of this sign is to be determined.

All such signs must be reviewed by Owner before fabrication or installation.

T05 - Tenant Interior Promotion Sign

The size, materials, and location of this sign is to be determined.

All such signs must be reviewed by Owner before fabrication or installation.

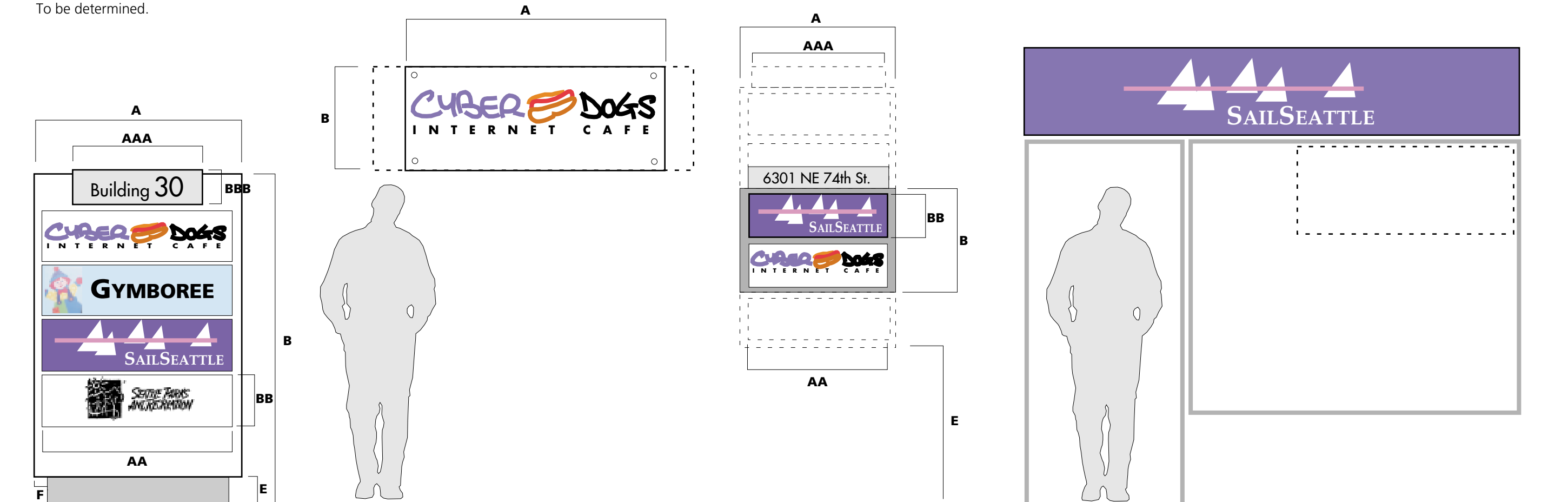

T01
Tenant Directory
@ Group Entrance

T02
Temporary
Tenant
Banner

T03
Tenant Changeable
Identification
Sign

T04
Tenant
Identification
Sign

T05
Tenant Interior
Promotion
Sign

12/22/04

T06 - Temporary Event Totem

Dimensions:
 A = 16" B = 24"
 D = 97" + - E = 9"
 J = 1" K = 12"

Artwork for each sculptural panel provided by Owner. Artwork for tenant signs provided by tenant. All signs must be approved by Owner before installation

Tenant sign slides into retaining rail on the top and bottom of each A-B panel which will retain a nominal poster board size of 15" x 20"

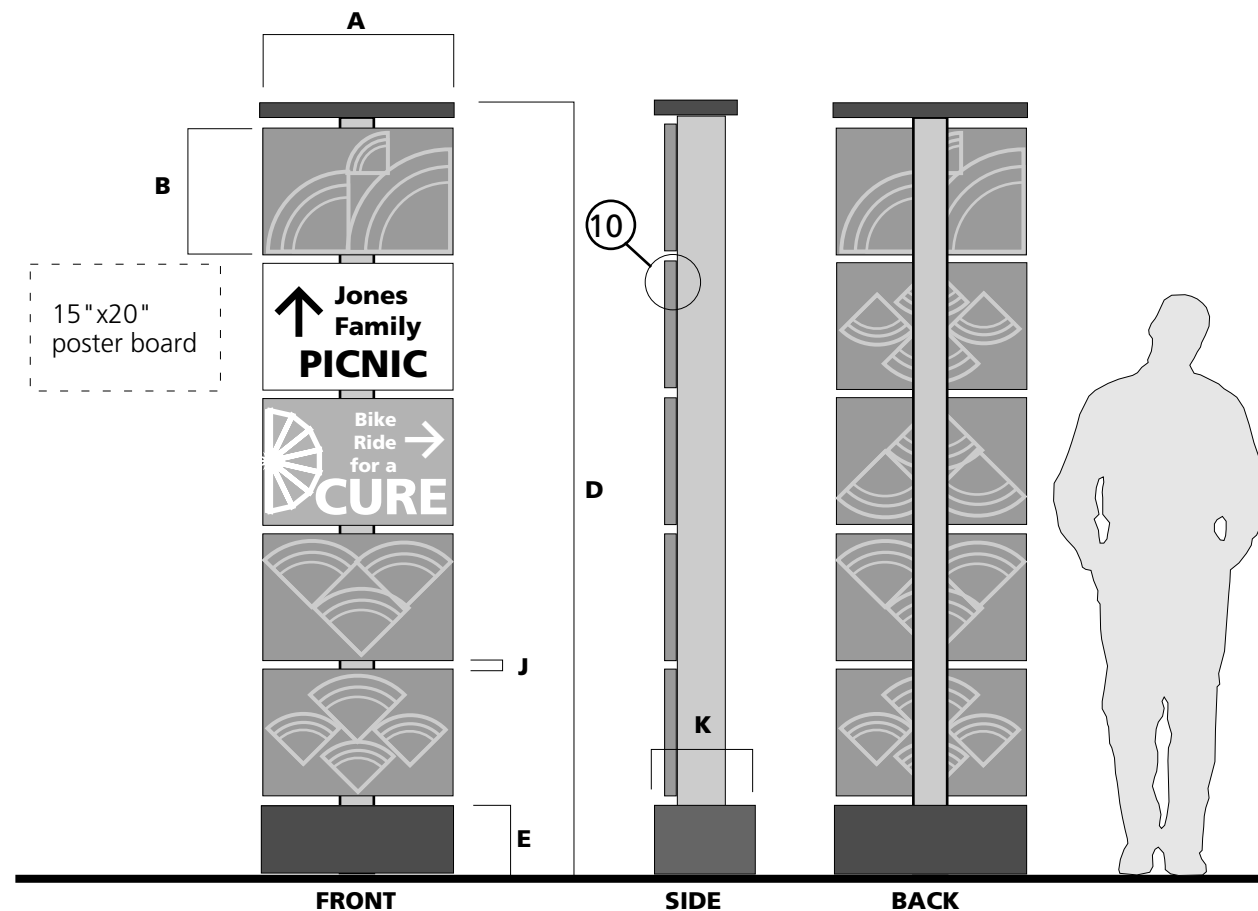

T06
Temporary Event
Totem
Sign

T07 - Banner Trellis @ Park Perimeter

This sign grouping is identical to T06 except several are grouped together.

All event banners must be approved by Owner before installation.

All banners must be removed the day after the event is complete.

A = 175" maximum
 J = 6" recommended

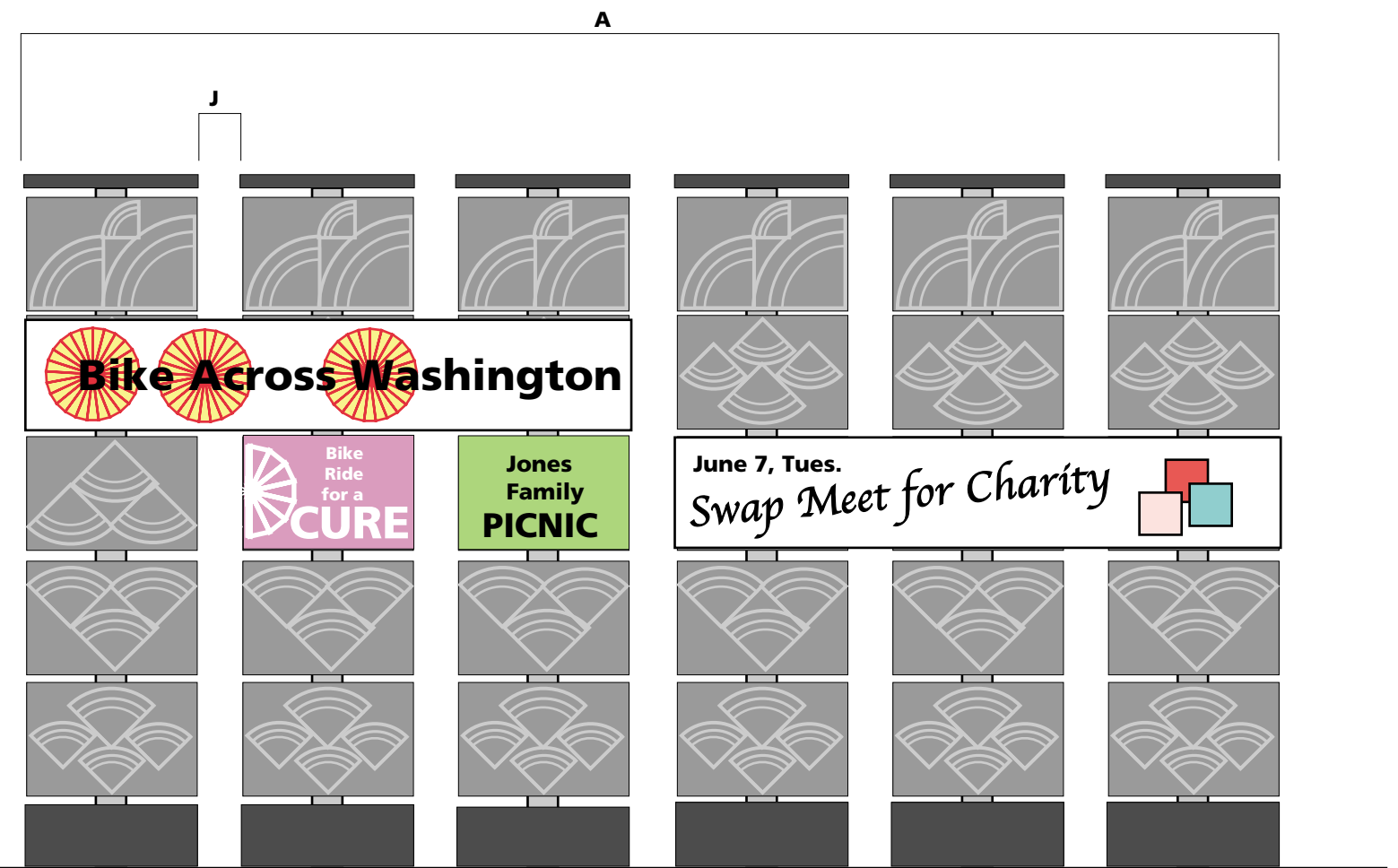

T07
Banner Trellis
@ Park Perimeter

- Park Feeder Road
- Primary Vehicular Circulation
- Secondary Vehicular Circulation
- Pedestrian Path Circulation
- Main Entry(s)
- Decision Points
- P Existing Parking Areas

Legend

- | | |
|-------------------|------------------------------|
| Information | Public Phone |
| Pedestrian Access | Restroom |
| Crosswalk | Bus Stop |
| Picnic Shelter | Public Art/Historic Monument |
| Picnic Table | Park Trails |
| Hand Boat Launch | Parking |
| | Buildings |

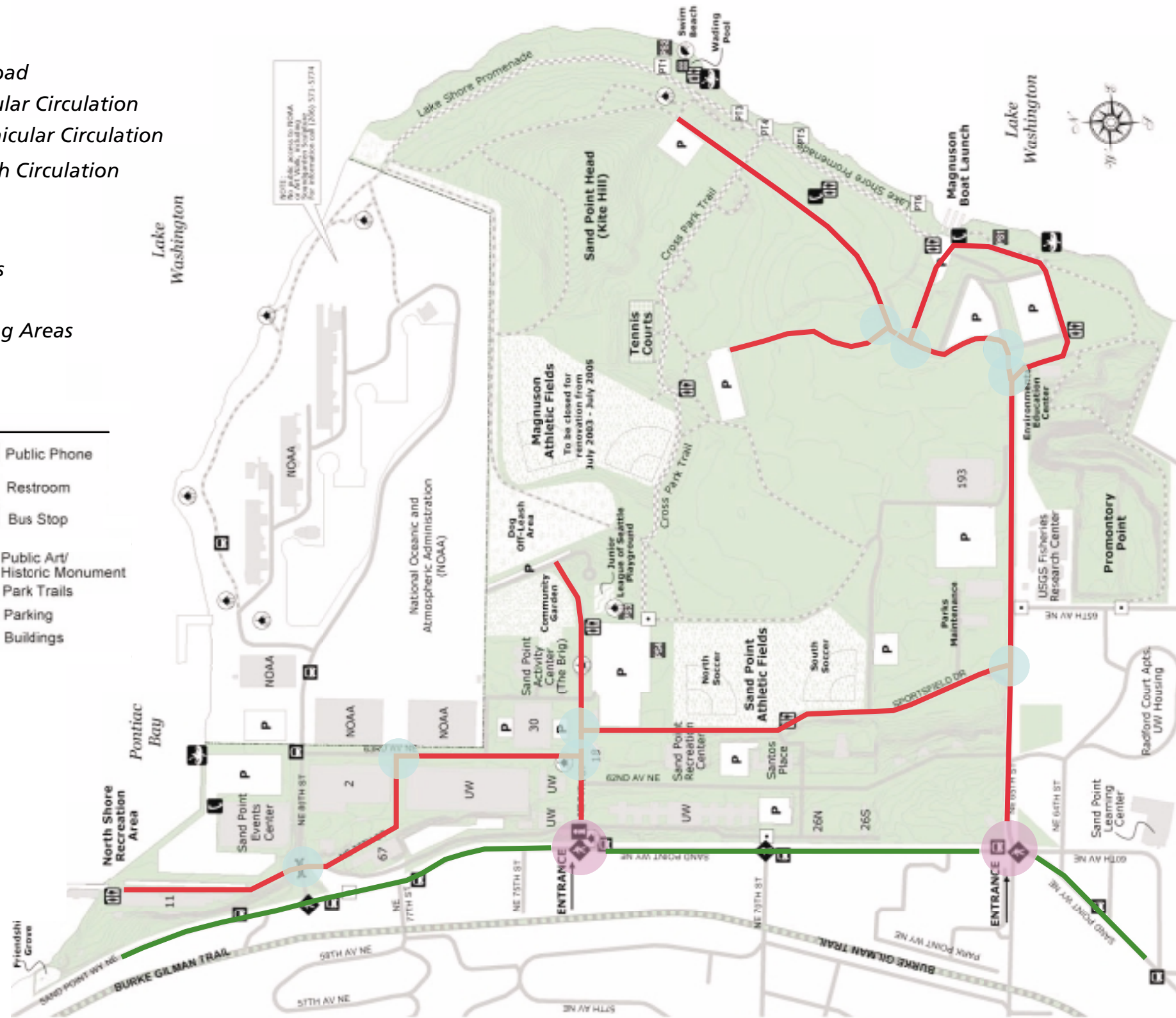

Site Nomenclature

Road & Path Names

- NE 65th Street Entrance
- NE 74th Street Entrance
- Cross Park Trail
- Lake Shore Promenade
- Sportsfield Drive
- 62nd Avenue
- 63rd Avenue

Sand Point Historic District

- Community and Event Center
- Friendship Grove
- North Shore Recreation Area
- Off-Leash Area
- Community Garden / Playground
- University of Washington
- Community Housing Association
- Seattle Parks and Recreation
- Activity Center
- Recreation Center

Shoreline Activities

- Athletic Fields
 - North Soccer
 - South Soccer
- Walking Trails
- Promontory Point / Kite Hill
- Boat Launch
- Tennis Courts
- Swim Beach
- Wading Pool
- Environmental Education Center
- Picnic Shelter (PS)
- Picnic Table (PT)
- Hand Boat Launch

Destination Buildings

- 2
- 11
- 18
- 26N
- 26S
- 30 (Parks Office)
- 67
- 193
- UW Buildings (4)

Services

- Information
- Public Phone
- Restroom
- Bus Stop
- Parks Maintenance

12/22/04

1571 Thorndyke Road
Port Ludlow, WA 98365
Tel (360) 437-9555
Fax (360) 437-9538
Email: kbd@olympus.net

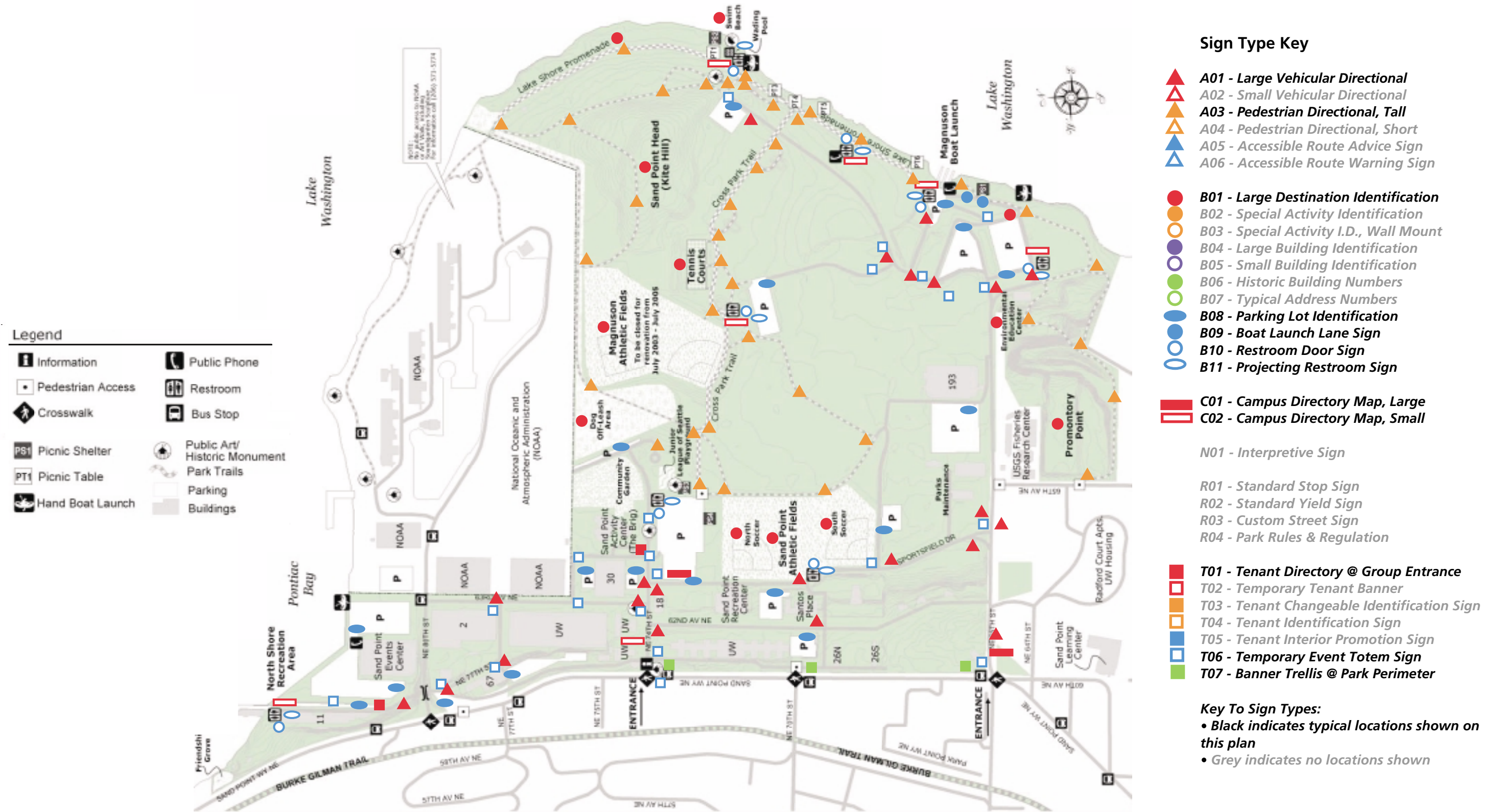

12/22/04

1571 Thorndyke Road
Port Ludlow, WA 98365
Tel (306) 437-9555
Fax (360) 437-9538
Email: kbd@olympus.net