

5 VICINITY MAP
SCALE: NTS

FINISH SCHEDULE

PRODUCT NAME	MANUFACTURER	MATERIAL	FINISH	COLOR SAMPLE
EXISTING FENCE	EXISTING	STEEL	GALVINIZED	
NEW FENCE	LOCAL Co	STEEL	GALVINIZED	
TABLE	EXISTING	WOOD / STEEL	PAINTED	SEE PICTURE #1
CHAIR	LOCAL Co	CHROME PLATED PLASTIC NYLON CHAIR LEGS		SEE PICTURE #2
NEW PATIO UMBRELLA	LOCAL Co	STEEL / FABRIC	BLACK / RED	SEE PICTURE #3

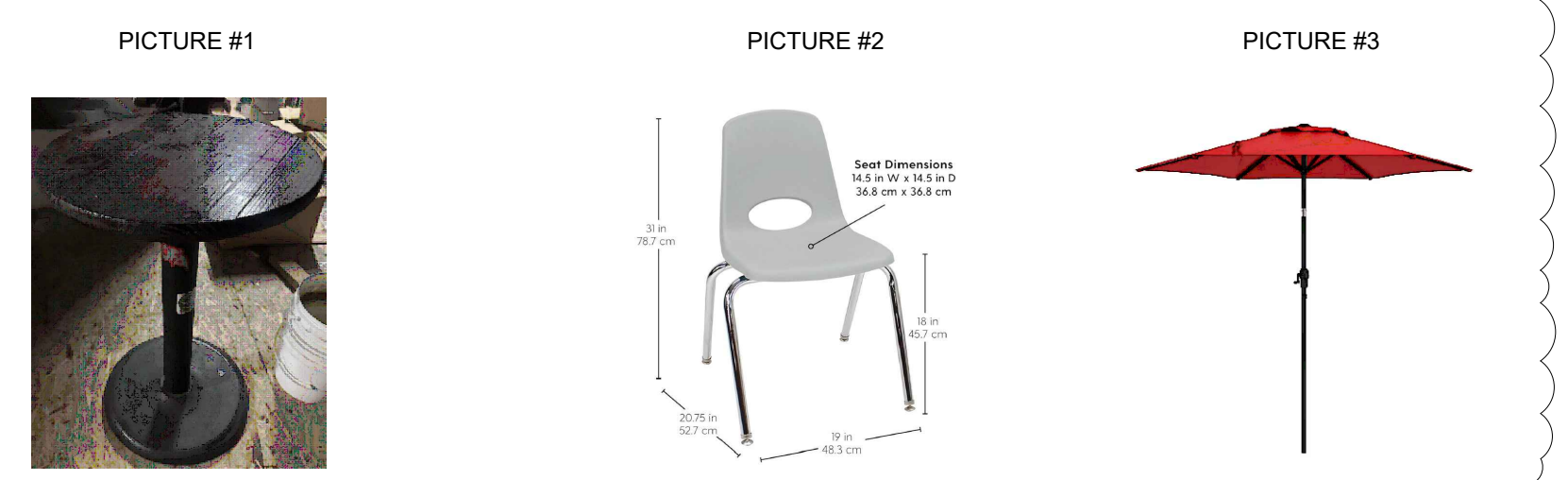

2 EXISTING CONDITION
SCALE: NTS

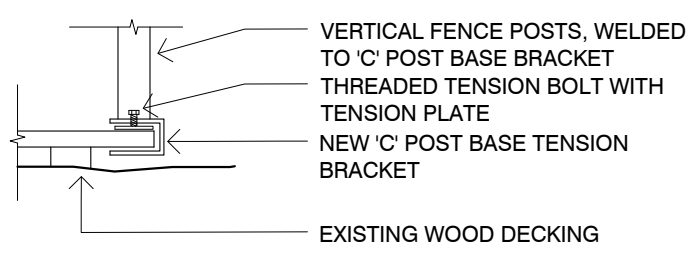

6 POST BASE DETAIL
SCALE: 1" = 1'-0"

NOTE: SIDEWALK CAFE AREA FENCING TO MEET ALL STANDARDS OF DIRECTOR'S RULE 03-2023 SECTION 6.4

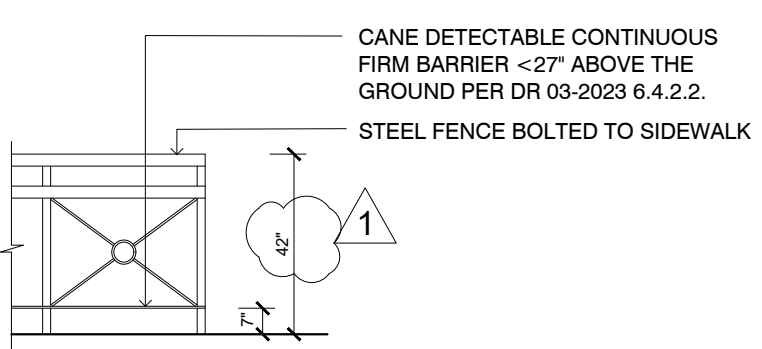

4 EXISTING FENCE
SCALE: 1/4" = 1'-0"

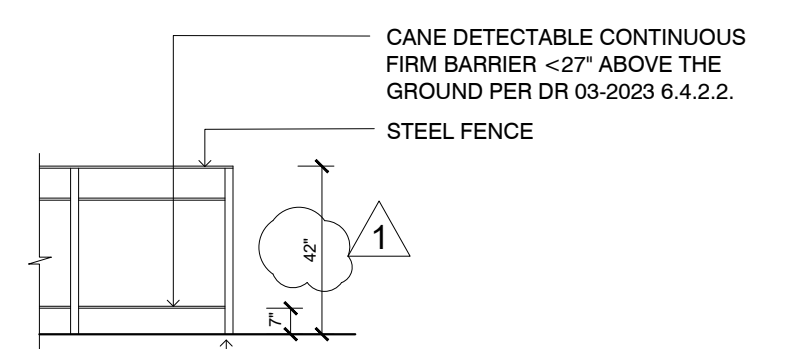

3 NEW FENCE
SCALE: 1/4" = 1'-0"

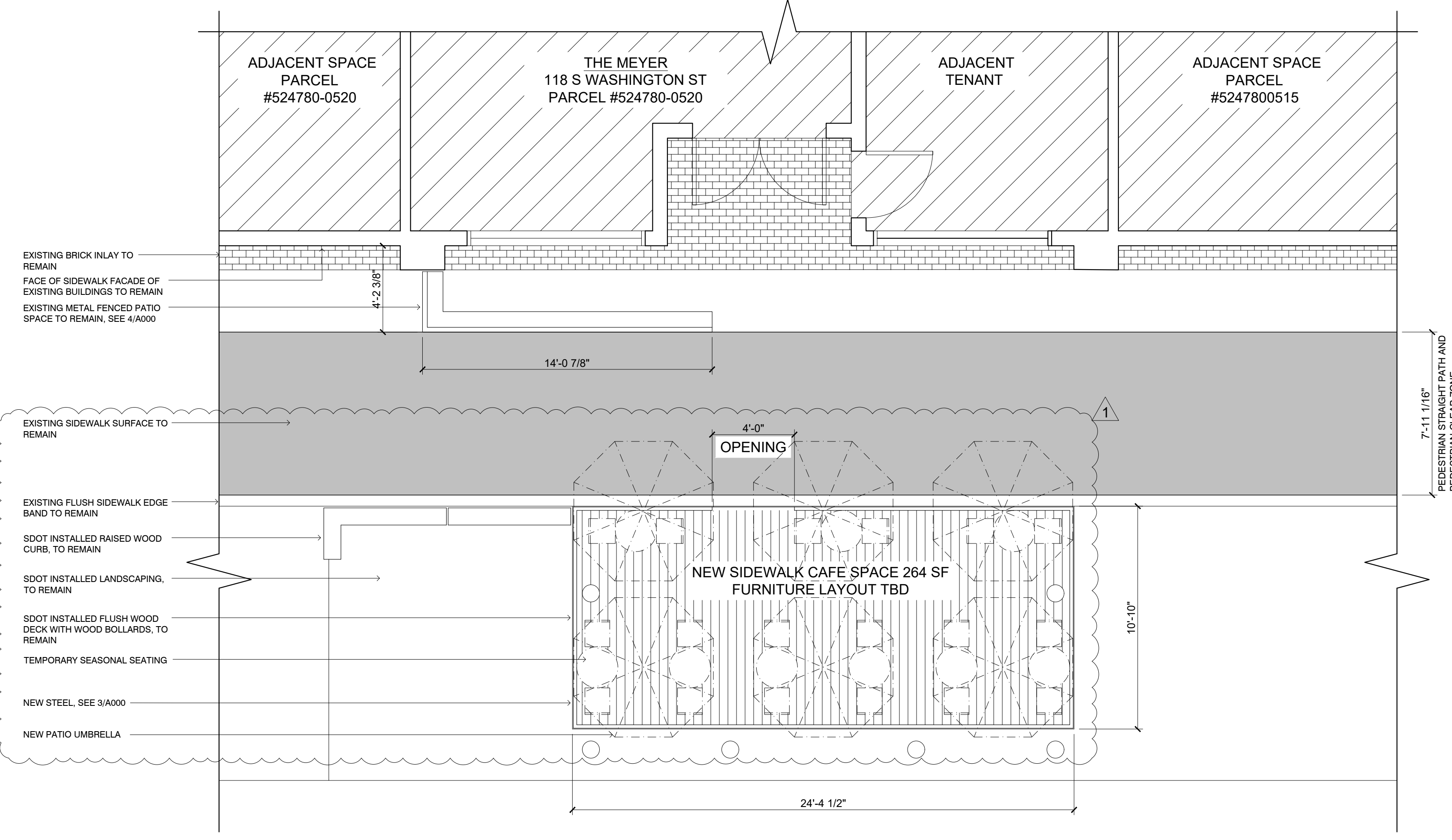

1 SITE PLAN
SCALE: 1/4" = 1'-0"

GENERAL NOTES

- ALL CONSTRUCTION SHALL BE DONE ACCORDING TO GENERAL NOTES AND CALCULATIONS SUBMITTED BY STRUCTURAL, MECHANICAL, AND ELECTRICAL ENGINEERS, AND IN ACCORDANCE WITH MOST CURRENT APPLICABLE CODES AND ORDINANCES.
- THESE DOCUMENTS ARE OF LIMITED SCOPE AND DO NOT COVER ALL CONSTRUCTION DETAILS, CONDITIONS, FINISHES OR PRACTICES. THE CONTRACTOR IS ASSUMED TO USE GOOD JUDGMENT IN THE EXECUTION OF THESE DOCUMENTS. BABIENKO ARCHITECTS PLLC SHALL NOT BE RESPONSIBLE FOR ANY ERRORS OR OMISSIONS FROM THE MISINTERPRETATIONS OF THESE DOCUMENTS. THE CONTRACTOR SHALL VERIFY ALL EXISTING AND NEW DIMENSIONS AND JOB CONDITIONS AND NOTIFY THE ARCHITECT OF ANY DISCREPANCIES PRIOR TO PROCEEDING WITH THE WORK. THE CONTRACTOR SHALL BE RESPONSIBLE FOR ALL SAFETY PRECAUTIONS AND THE METHODS, TECHNIQUES, SEQUENCE OR PROCEDURES REQUIRED TO PERFORM THE WORK.
- IT IS THE CONTRACTOR'S RESPONSIBILITY TO VERIFY ALL EXISTING CONDITIONS AND DIMENSIONS BEFORE COMMENCING WORK. DISCREPANCIES, IF ANY, ARE TO BE REFERRED TO THE ARCHITECT IMMEDIATELY FOR DETERMINATION ON HOW TO PROCEED.
- IT IS THE CONTRACTOR'S RESPONSIBILITY TO PROTECT EXISTING WORK TO REMAIN. ANY SUCH ITEM DAMAGED OR DESTROYED BY THE WORK OF THIS CONTRACT IS TO BE REPAIRED OR REPLACED TO ITS ORIGINAL CONDITION.
- DIMENSIONS ARE TO: FACE OF GWB, OR FACE OF CONCRETE (FOC), OR GRID LINE, OR CENTER LINE, OR AS INDICATED ON THE DRAWINGS.
- REFERENCING OF DRAWINGS IS FOR CONVENIENCE ONLY AND DOES NOT LIMIT APPLICATION OF ANY DRAWING OR DETAIL.
- CONTRACTOR SHALL PROVIDE ALL WORK INDICATED ON THE DRAWINGS AND DESCRIBED IN THE SPECIFICATIONS. THE WORK INDICATED ON THE DRAWINGS IS TO BE GOVERNED BY ALL RELEVANT SECTIONS OF THE SPECIFICATIONS THOUGH CROSS REFERENCES MAY OR MAY NOT BE STATED EXPLICITLY. THE DRAWINGS AND SPECIFICATIONS ARE COMPLEMENTARY TO EACH OTHER. WHAT IS DESCRIBED OR INDICATED ON ONE IS BINDING AS IF CALLED ON IN BOTH.
- WHERE ADJOINING ROOMS HAVE DISSIMILAR FLOORING, MAKE CHANGE UNDER CENTERLINE OF DOOR, UNLESS OTHERWISE SHOWN.
- DIFFERING PARTITION TYPES (I.E. WHERE EXISTING PARTITIONS RUNS INTO NEW) SHALL ALIGN SO THAT WALL PLANES CONTINUE UNBROKEN WITHIN ROOMS UNLESS NOTED OTHERWISE.
- THE CONTRACTOR SHALL VERIFY ALL ROUGH-IN DIMENSIONS AND EQUIPMENT FURNISHED AND INSTALLED BY CONTRACTOR OR OTHERS PRIOR TO PROCEEDING WITH THE WORK.
- THE CONTRACTOR SHALL COORDINATE WITH ALL OWNER FURNISHED ITEMS AND PROVIDE ALL REQUIRED MECHANICAL AND ELECTRICAL CONNECTIONS, INCLUDING STUB OUTS FOR NEW AND FUTURE WORK (FUTURE WORK ONLY IF NOTED TO CONTRACTOR IN WRITING).
- DO NOT SCALE DRAWINGS.
- CONTRACTOR SHALL REPAIR, AND PATCH ALL EXISTING STRUCTURES AND FINISHES WHERE ALTERATIONS OR NEW CONDITIONS ABUTT, JOIN, OR INTEGRATE TO EXISTING CONDITIONS.
- AT NON-LOAD BEARING STUD PARTITIONS, STUDS ARE TO EXTEND FROM FLOOR TO UNDERSIDE OF STRUCTURE ABOVE, UNLESS OTHERWISE NOTED. WHERE PARTITIONS CANNOT EXTEND TO STRUCTURE, DUE TO INTERFERENCE OF DUCTS, PIPING, ETC., PROVIDE BRACING TO STRUCTURE ABOVE TO PROVIDE FOR EQUIVALENT SUPPORT OF PARTITION.
- ALL WOOD IN CONTACT WITH CONCRETE, MASONRY, OR SOIL SHALL BE SEPARATED USING AN UNDERLAYMENT / MOISTURE BARRIER, EXCEPT WHERE EXISTING FLOOR IS NOT DEMOLISHED.
- PROVIDE BLOCKING AT ALL WALL MOUNTED ITEMS, REFER TO INTERIOR ELEVATIONS.
- CONTRACTOR SHALL PROVIDE SHOP DRAWINGS FOR ALL METAL FABRICATIONS AND CABINETS TO ARCHITECT FOR APPROVAL PRIOR TO PROCEEDING WITH MATERIAL ORDER OR MANUFACTURE.

PROJECT DIRECTORY

OWNER
AVOUT VAN DER WERF
WAWA LLC DBA THE MEYER
118 S WASHINGTON ST
SEATTLE, WA 98104

ARCHITECT
JEFF BABIENKO, AIA LEED AP
BABIENKO ARCHITECTS PLLC
815 SEATTLE BOULEVARD SOUTH
SEATTLE, WA 98134
PH 206.223.7663

GENERAL CONTRACTOR
TBD

PROJECT INFORMATION

PROJECT DESCRIPTION
EXISTING SIDEWALK CAFE IN FRONTAGE ZONE DEFINED BY EXISTING FENCE TO REMAIN AND A NEW SIDEWALK CAFE IN THE FURNITURE ZONE ON A NEW WOOD DECK AREA CONSTRUCTED BY SDOT.

NO CHANGE TO BUILDING FOOTPRINT.

ASSESSOR PARCEL #
524780-0520

LEGAL DESCRIPTION
MEYARDS D S PLAT W 28 2/3 FT OF E 91 2/3 FT W
PLAT BOOK 8
PLAT LOT: 5

PROJECT STREET ADDRESS
118 S WASHINGTON STREET
SEATTLE, WA 98104

DRAWING LIST

A000 COVER SHEET/ SITE PLAN / CONTACTS / FENCE DETAILS

BUILDING CODES

- 2018 SEATTLE BUILDING CODE
- 2018 UNIFORM BUILDING CODE
- 2018 SEATTLE MECHANICAL CODE
- 2018 SEATTLE FUEL GAS CODE
- 2018 NATIONAL ELECTRICAL CODE
- 2018 SEATTLE FIRE CODE
- 2018 SEATTLE ENERGY CODE-COMMERCIAL
- 2010 ADA STANDARDS FOR ACCESSIBLE DESIGN
- SEATTLE ZONING CODE
- 2018 SEATTLE MUNICIPAL CODE
- 2018 SEATTLE EXISTING BUILDING CODE

NOTE: ALL WORK SHALL CONFORM TO THE CODES LISTED ABOVE AND ANY AMENDMENTS IN FORCE AT THE TIME OF PERMITTING AND CONSTRUCTION. THE CONTRACTOR IS RESPONSIBLE FOR WORK CONFORMING TO ALL CURRENT CODES DURING THE COURSE OF CONSTRUCTION; WHETHER LISTED ABOVE OR IN ADDITION TO THE CODES NOTED ABOVE.

TYPICAL ABBREVIATIONS

- AHU AIR HANDLING UNIT (FURNACE)
- BLKG BLOCKING
- CONC. CONCRETE
- DTL. DETAIL
- D.S. DOWNSPOUT
- EL. ELEVATION
- EXIST. EXISTING CONSTRUCTION (E)
- EXT. EXTERIOR
- FT. FOOT / FEET
- GA. GAUGE
- GWB. GYPSUM WALL BOARD
- HT. HEIGHT
- IN. INCH / INCHES
- MFR. MANUFACTURER
- N.I.C. NOT IN CONTRACT
- PT. PRESSURE TREATED PRESERVATIVE
- QTY. QUANTITY
- REFR. REFRIGERATOR
- R.J. ROUGH OPENING
- SBC SEATTLE BUILDING CODE
- SCH. SCHEDULE
- SW. SHEAR WALL
- TEL. TELEPHONE
- T&G. TONGUE AND GROOVE
- TOW. TOP OF WALL
- TYP. TYPICAL
- WD. WOOD
- W/ WITH
- W/O WITHOUT
- WH. WATER HEATER
- V.I.F. VERIFY IN FIELD

CORRECTION 02.10.2025
PERMIT APPLICATION SET 01.10.2025

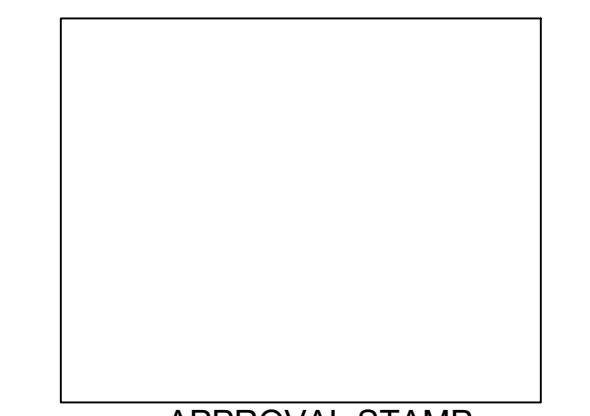
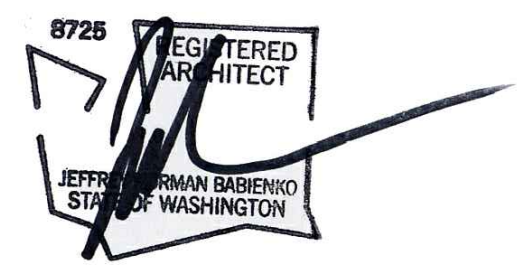

architect
babienco ARCHITECTS pllc

PROJECT
THE MEYER

TITLE SHEET
PROJECT DATA & SITE PLAN

A000

ISSUE
SIDEWALK CAFE PERMIT

DATE
JANUARY 7, 2025

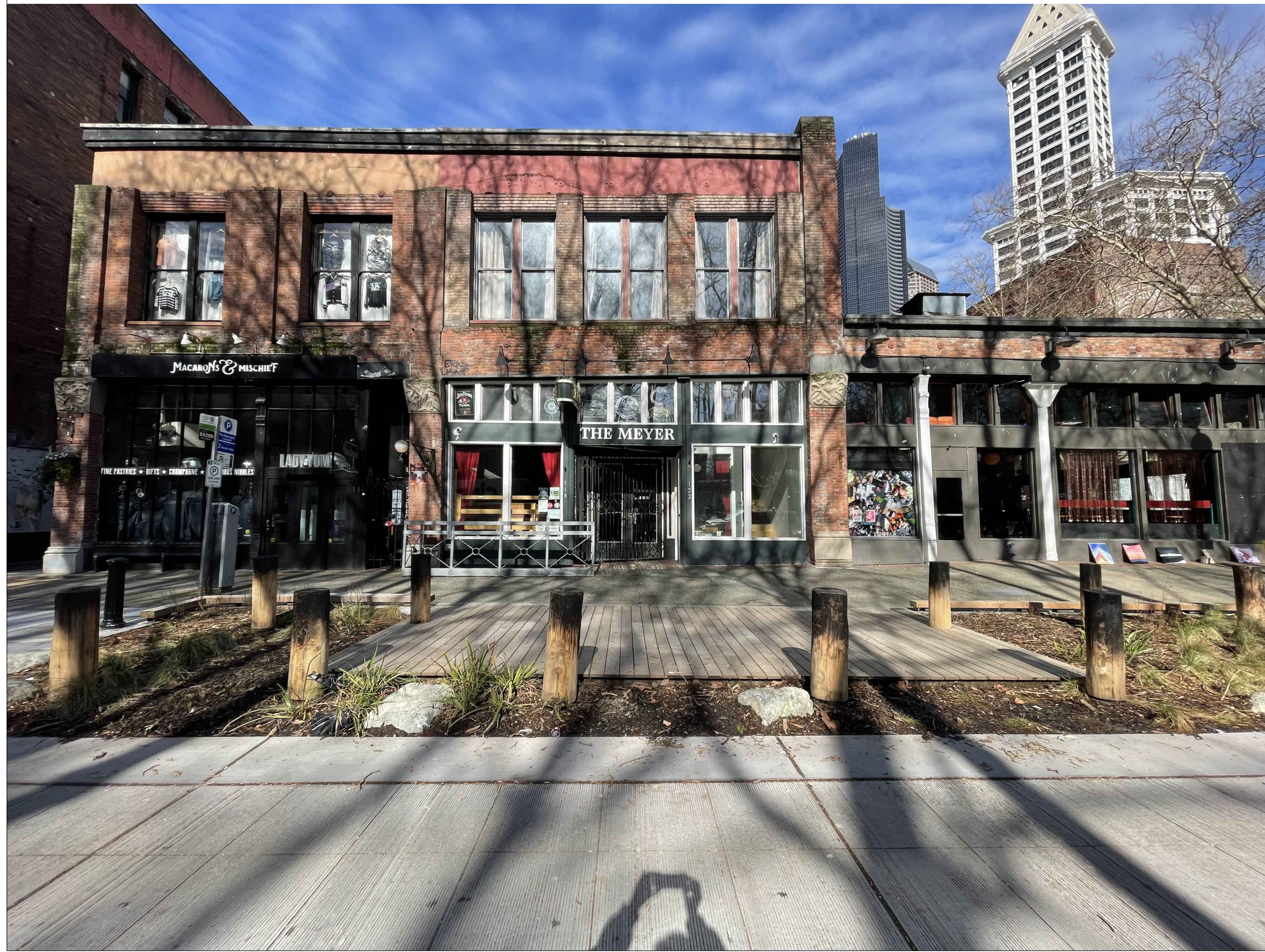

1 VIEW #1 EXISTING
SCALE:



2 VIEW #2 EXISTING
SCALE:



3 VIEW #1 PROPOSED
SCALE:



4 VIEW #2 PROPOSED
SCALE:

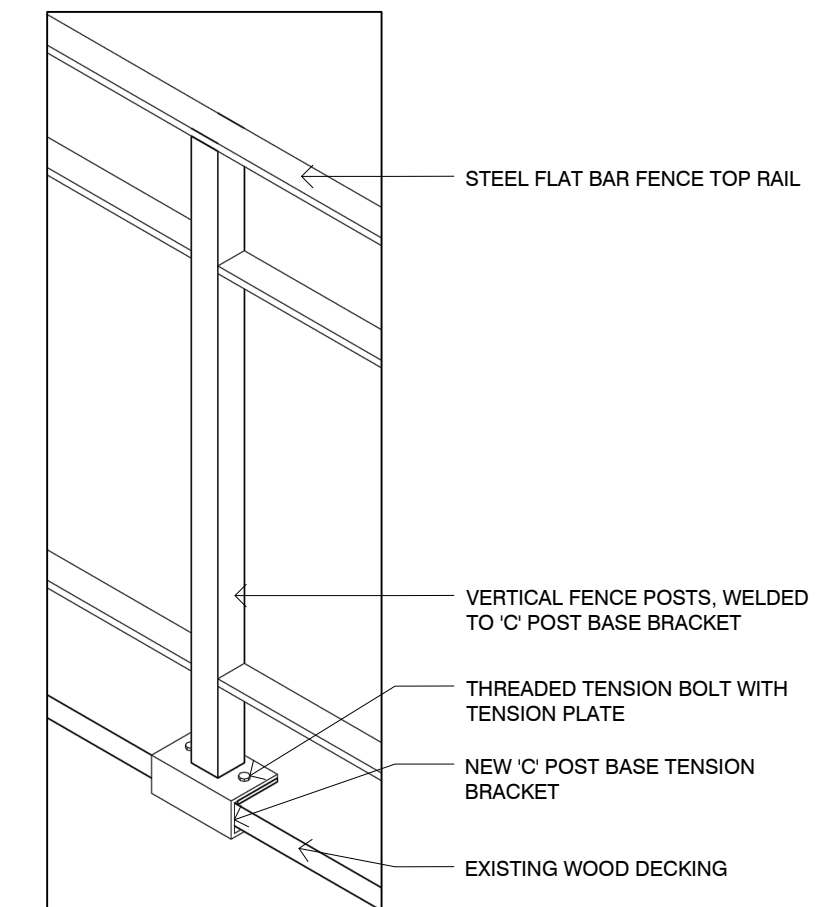

5 FENCE BASE DETAIL
SCALE:

△ CORRECTION 02.10.2025
PERMIT APPLICATION SET 01.10.2025

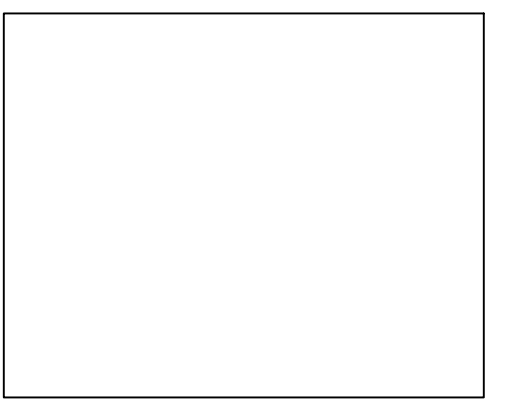
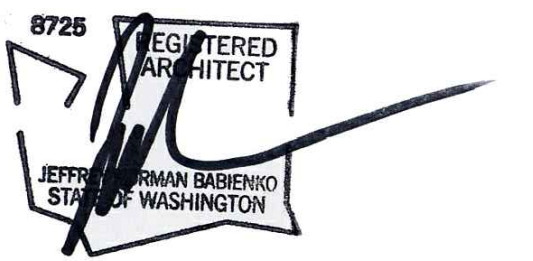

architect
babienko ARCHITECTS pllc

PROJECT
THE MEYER

TITLE SHEET
RENDERINGS

A001

ISSUE
SIDEWALK CAFE PERMIT

DATE
JANUARY 7, 2025