

Approximate street location
(It's possible raven could rotate and tilt slightly)

Raven Scorched by Fire

A PERMANENT PUBLIC ARTWORK
AT THE 3RD AVE S AND S MAIN ST BUS STOP

Pioneer Square Preservation Board Early Guidance
April 2024

PROJECT BACKGROUND

The Third Avenue Transit Corridor is used by tens of thousands of people each day and a quarter of the buses that operate in the corridor pick up passengers at 3rd Ave S and S Main St in Pioneer Square. With more than 2,650 average daily riders and 24 different routes served, it has become King County Metro's 10th busiest stop. To create a safer, more accessible, and more reliable experience for people catching the bus at this heavily trafficked location, Metro and the City of Seattle Department of Transportation (SDOT) are repairing and reconfiguring the streetscape and installing new amenities, including a signature sculpture by artists Preston Singletary and David Franklin.

The public art project is now in the conceptual design stage, and the project team is seeking feedback from PSPB and other community stakeholders. 4Culture is managing the project on behalf of King County, working closely with Metro and SDOT.





Preston Singletary, *Raven Plotted*, 2023. Blown and sand carved glass.

Raven Scorched by Fire

A PERMANENT PUBLIC ARTWORK
AT THE 3RD AVE S AND S MAIN ST BUS STOP

ARTWORK INSPIRATION

“Nass Shaak Aankáawu (Nobleman at the Head of the Nass River) was hoarding many treasures, including the light. When Yéil (Raven) learned that the man had a daughter who drank from a stream every morning, Yéil turned himself into a hemlock or spruce needle and floated into her cup. She drank him; became pregnant; and Yéil, born in human form, became the love of their lives. Nass Shaak Aankáawu provided every luxury and toy to his precocious grandson. When the child cried for the boxes that held the stars, the moon and the sun, his grandfather could not refuse him.

One by one, Yéil T’ukanéiyi (Raven Baby) incessantly cried for and released the stars, the moon and the daylight, much to the dismay of Nass Shaak Aankáawu but much to the benefit of the people and animals of the world. Realizing he was the victim of extreme deceit, Nass Shaak Aankáawu forever marked Yéil by holding him in the smoke of the fireplace, altering his color, turning him from the white spiritual being into the black color he is today.”





Preston Singletary & David Franklin, *Raven's Escape*, 2023. Glass, metal, and custom lighting. Microsoft Redmond Campus, Redmond, WA.

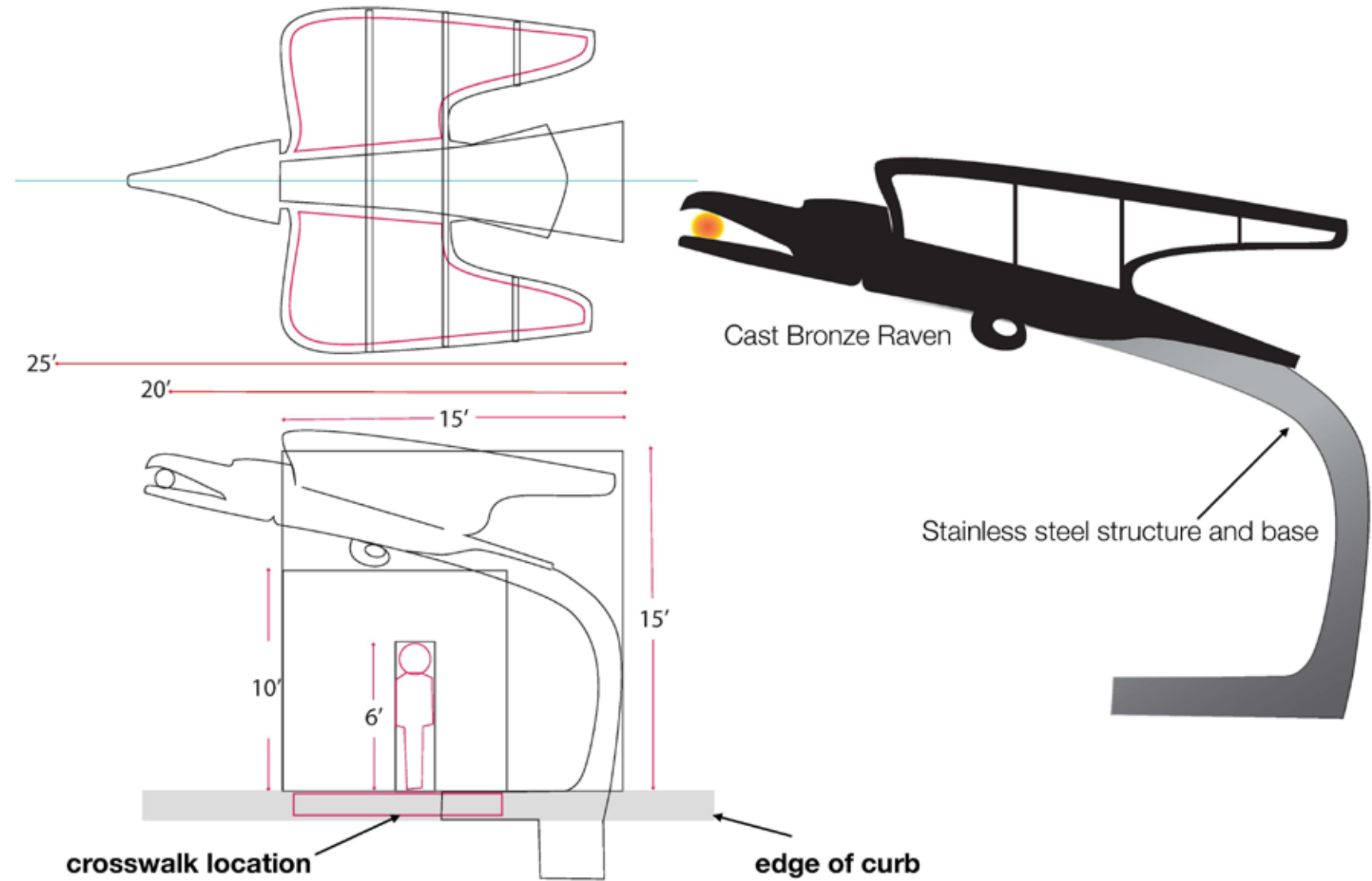

Raven Scorched by Fire

A PERMANENT PUBLIC ARTWORK
AT THE 3RD AVE S AND S MAIN ST BUS STOP

Pioneer Square Preservation Board Early Guidance
April 2024

DESIGN CONCEPT

Inspired by the story of Yéil, the sculpture captures the moment of transformation. Preston Singletary's sculptures merge themes from Tlingit mythology and traditional design, and he is recognized internationally for his use of glass as well as other non-traditional materials to bring new dimension to contemporary Indigenous art. David Franklin brings an expertise in fabrication, project management, and community engagement to the artist team.

The design for the sculpture incorporates a pedestal with a cantilever to create an iconic wayfinding element and beacon for the neighborhood while also providing the multi-purpose benefit of shelter for pedestrians waiting to cross the street. The sculpture can be tilted and will be designed to accommodate overhead wires and ROW restrictions. 4Culture, Metro, and SDOT are working with the artists and their engineers to respond to all site restrictions. Lighting will be incorporated into the glass and base of the sculpture.



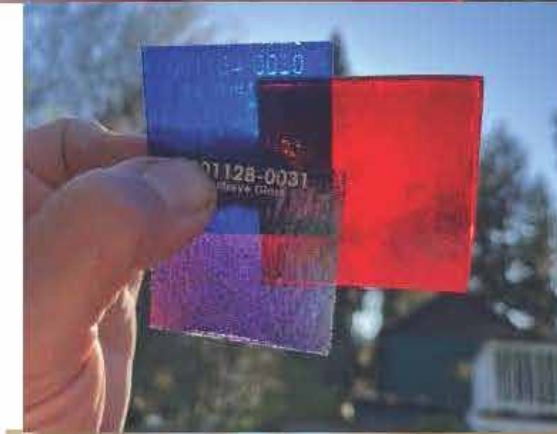
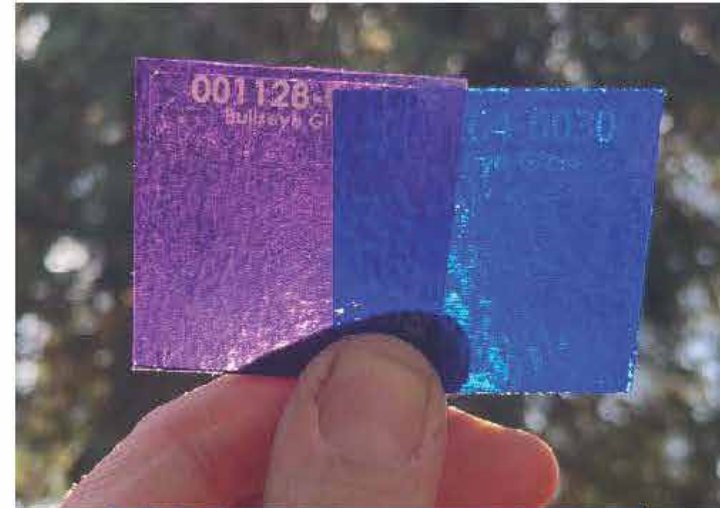
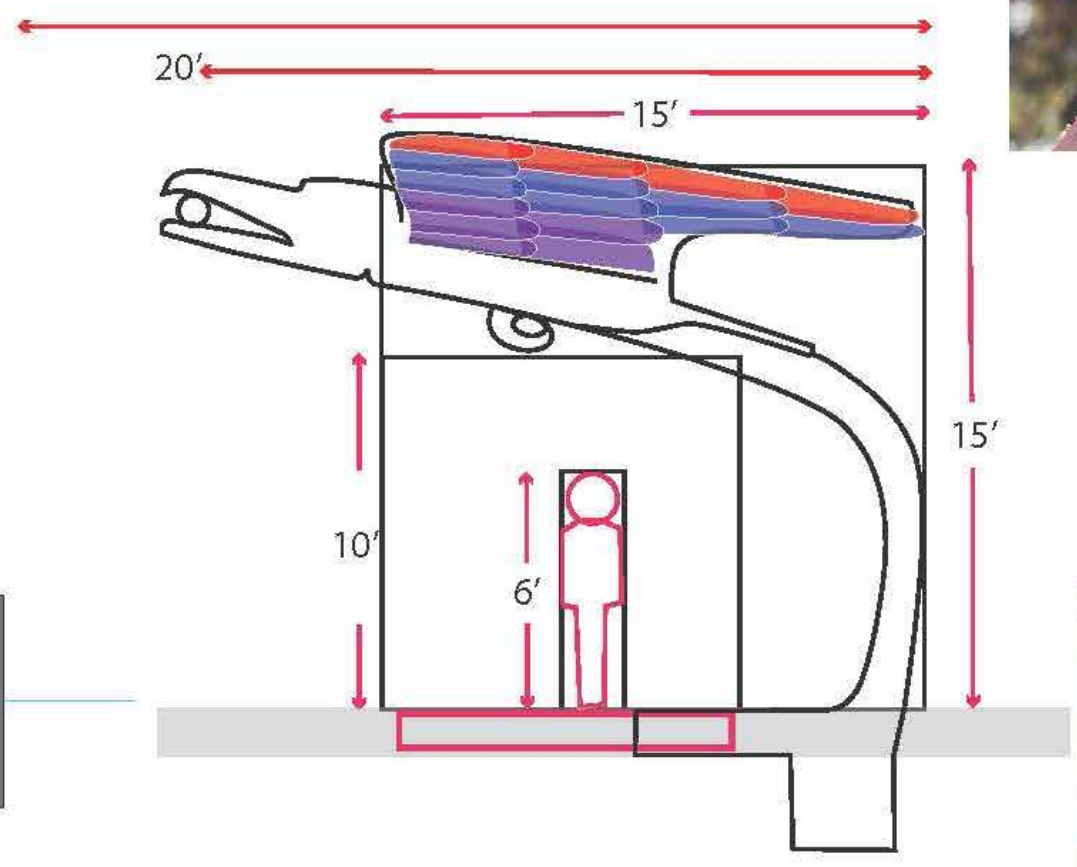

Raven Scorched by Fire

A PERMANENT PUBLIC ARTWORK
AT THE 3RD AVE S AND S MAIN ST BUS STOP

Pioneer Square Preservation Board Early Guidance
April 2024

PROPOSED MATERIALS

Artists Preston Singletary and David Franklin are exploring materials and lighting, and will further develop their approach based on feedback from engineers and project stakeholders including the PSPB. The current design is a bronze Raven body inset with glass shingles in colors evoking feathers and the purple of the Pioneer Square prism glass. The bronze may incorporate carved textures and a dark black patina. The base and footing of the sculpture is proposed to be stainless steel, a durable and easy-to-maintain material and an accompanying stainless steel plinth will include a plaque for information about the artwork with a summary of the story of Yéil (Raven).

