



KITCHEN
&
MARKET

KITCHEN
&
MARKET

DELIGHT

STOP



KITCHEN & MARKET

KITCHEN & MARKET

KITCHEN & MARKET

1926 PIKE PLACE (KITCHEN & MARKET)

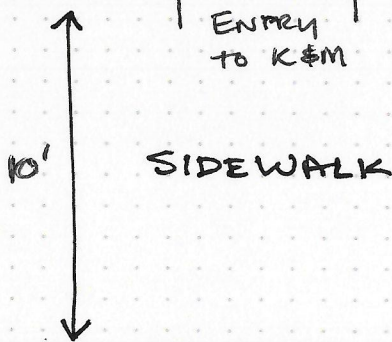

Minimum 3-ft clearance shall be maintained from existing lamp post.
If there is a wheel stop, this clearance is from the wheel stop. Otherwise this clearance is from the cafe itself.

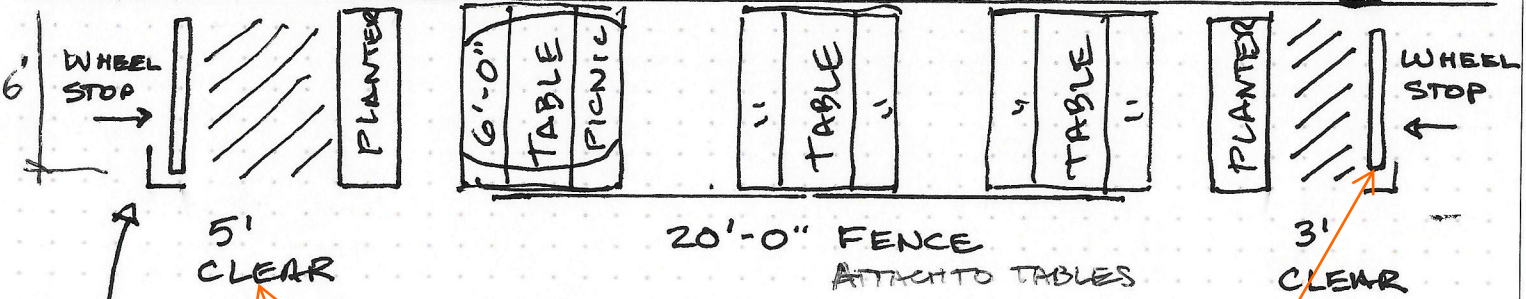
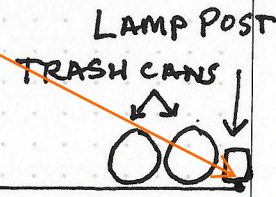

This wheel stop only necessary if no neighboring cafe. Hellenika next door has also applied for a cafe adjacent to this one.

5' CLEAR
6' x 40'

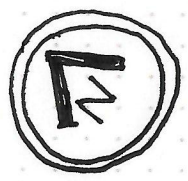

PIKE PLACE



Reduce to 3-ft clearance



SDOT Permit Number(s)

(Official Use Only)

SITE PLAN - BLANK

June 2019

24 Hour Contact: _____

Phone Number: _____

Project Address: _____

Email: _____

INSTRUCTIONS - see CAM 2116 for further guidance

1. Label all street names.
2. Clearly outline area(s) proposed for use.
3. Show all dimensions for work areas. Include setback distances from curbs, centerlines, driveways, right of way width, etc.
4. List affected street frontages in the table below.

Frontages	Work Area (sq. ft.)	Right of Way Impacts						
		Sidewalk	Planting Strip	Parking Lane	Bike Lane	Travel Lane	Alley	Unimproved Right of Way
Nw 65th St	30' x 10'			X	X			

5. Draw existing features on the site plan to the left.

- Trees, tree pits, drip lines
- Power poles, cabinets, pay-to-park kiosks
- Fire hydrants
- Street fixtures (bike racks, fixed trash containers, etc.)
- Vaults/meter boxes
- Areaways
- Storm drain grates/manhole covers
- Parking: metered/disabled
- Loading zones
- Transit or bus zones
- Trolley lines/tracks
- Near curb ramps
- Marked surfaces

Notes/Inspector Comments:

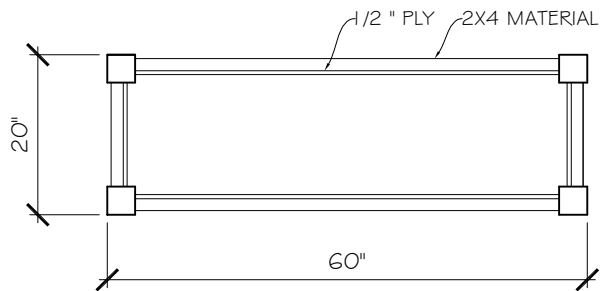

○ PLAN VIEW

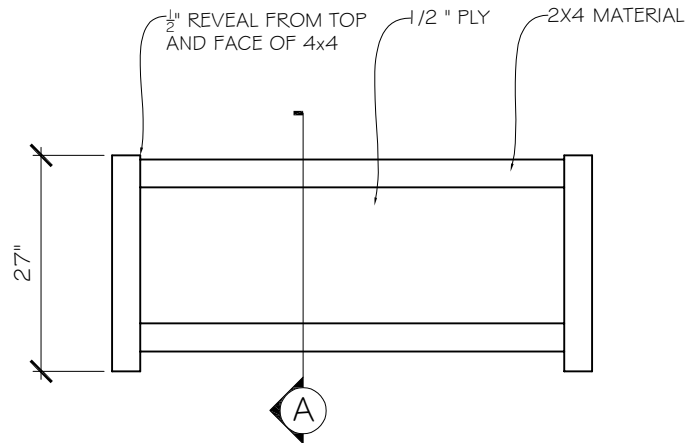

○ FRONT ELEVATION

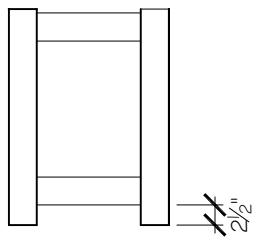

○ SIDE ELEVATION

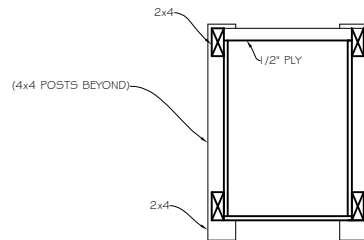

○ SECTION A

NOTES:

- CONTRACTOR TO ALTER CONSTRUCTION METHOD AS FIT. PLEASE CONSULT DESIGNERS FOR CHANGES TO APPEARANCE.
- FRAMING LUMBER & PLY TO BE PAINTED BENJAMIN MOORE "BLACK 2132-10"

The picnic tables are a standard wood 6' table stained white, railing to match

Planter will be painted Black

Umbrellas will be Black

KITCHEN & MARKET - MADISON VALLEY
EXTERIOR PLANTERS - 4/1/2024

1/2" = 1'-0"