



MAYNARD ALLEY MURALS

International Special Review Board
(ISRD) Application for Certificate of
Approval

Julie Yuan, SCIDpda

Friends of Maynard Alley

NARRATIVE

To Rebecca Frestedt and the International Special Review Board,

Introduction:

We are seeking ISRD approval to install art murals permanently in the Maynard Alley. Within the Chinatown-International District, Maynard Alley has significant placement. The majority of the buildings that front this section of the alley are historic carrying with it layered stories of the neighborhood over the years as home to new Asian immigrant populations evolving into the vibrant diverse place that exists today. Currently bounded by what are arguably the most active commercial streets in the neighborhood, it offers a wide variety of businesses from restaurants and retail to a variety of community services such as health professionals, theater, dance studio and the local newspaper.

SCIDpda worked with Zero Plus (an architecture and design firm located in the CID) between 2018 - 2019 to conduct several rounds of community engagement for Maynard Alley. The community was excited to study options of what might occur in the alley and invested time in providing valuable feedback of their interests and priorities for future development. Nearly 200 surveys were collected in total and included a diverse representation of business owners, employees, residents, building owners and visitors to the neighborhood. A planning and design master plan was published; it summarized the community engagement findings and provided several design and alley activation recommendations. Art was one of the recommendations from the master plan and murals were the most desirable art elements among overall survey responders. Highly visible and impactful, murals can be the first layer to attract interest of visitors and are an effective means of providing depth of understanding of history and cultural overlay.

With funding from the Office of Economic Development, SCIDpda worked with four local Seattle artists, Zoulie Deng, Tom Dang, Taylor Yingshi, and Angelina Villalobos Sototo, to paint murals on plywood boards. Artists were asked to interpret the theme of “the red thread,” which is based on a Chinese proverb—“an invisible red thread connects those who are destined to meet regardless of time, place or circumstance. The thread may stretch or tangle, but will never break.” The murals were completed in 2020; these murals are currently placed in vacant ground floor store fronts in Maynard Alley and they add color and vibrancy to the alley.

We are aiming to install the four art murals in August 2023. We will host a small celebration in Maynard Alley once the murals are installed. This will be a celebration of the installation of the four art murals with the community and the artists involved.

The Maynard Alley art murals are a celebration of the rich history of the Chinatown International District and the community. We are excited to have the chance to permanently install them and to move a step forward in the vision that the community has built for Maynard Alley.

NARRATIVE

Project Goals:

- Create a welcoming and vibrant passageway through Maynard Alley
- Celebrating local Asian American artists and residents

Scope of Project:

- 4 murals installed at New Central Apartments, in the Maynard Alley
- Community celebration in August after the installation of the murals

Proposed Design:

This proposed design includes the installation of 4 art mural panels along the wall of the New Central Apartments building, in the Maynard Alley. The murals will be attached to the wall using ss bolts and inserts through the mortar joints between the bricks. We will be working with contractors from Pioneer Masonry Restoration Company, who have a long history of working on historic brick building restoration. They will ensure the protection of the bricks when installing the murals.

CONTEXT & SITE PLAN



KEY

- A** Milwaukee Apartments
- B** Louisa Apartments
- C** Eastern Hotel
- D** Rex Apartments
- E** Atlas Apartments
- F** New Central Apartments

EXISTING SITE

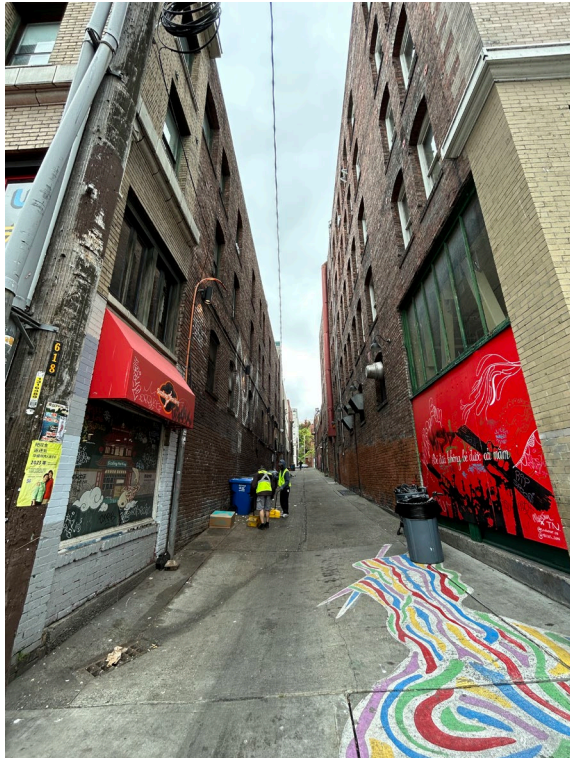

**Alley view point:
North-facing**

EXISTING SITE



**Alley view point:
South-facing**

COMMUNITY SUPPORT

Parties involved in Maynard Alley Art Murals:

- SCIDpda
- Maynard Alley Partnership
- Historic South Downtown

Ownership & Maintenance Plan

- New Central Apartments (SCIDpda)

Mural maintenance will be provided by SCIDpda



COMMUNITY ENGAGEMENT - MAYNARD ALLEY

A presentation was made at the summer Jam Fest event with large posters. Nearly 200 surveys were collected in total and included a diverse representation of business owners, employees, residents, building owners and visitors to the neighborhood. In addition, the survey was distributed to neighborhood residents and business owners after the event. After tallying all of the surveys, murals were the top choice for art activation in Maynard Alley.

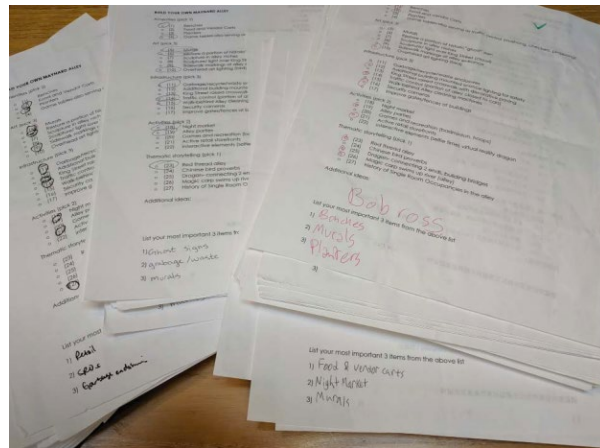

The following is an overview of the survey compilation of most desired options for Maynard Alley by category:

Infrastructure top responses:

- 1) garbage, waste, recycle
- 2) additional lighting
- 3) traffic control
- 4) raised crosswalk at King Street

Amenities top responses:

- 1) vendor Carts
- 2) planters

Art top responses

- 1) murals
- 2) overhead art lighting (in the alley and at King Street crossing)
- 3) restore part of ghost sign at Michigan hotel

Activities top responses

- 1) Night Market
- 2) Alley Parties
- 3) active storefronts

themes top responses:

- 1) dragon bridging two ends
- 2) history of SRO in the alley
- 3) red tread alley / magic carp

Participants listed their top 3 options of the entire list in following tally:

- 1) Murals
- 2) food and vendor carts
- 3) night market
- 4) garbage and recycle bins
- 5) overhead art lighting in the alley
- 6) building lighting

COMMUNITY ENGAGEMENT - ART MURALS

Community engagement for the art murals took place during the height of the pandemic; we were not able to gather community members for community engagement and many small businesses were closed. We conducted abbreviated engagement which included working with the Wing Luke Museum to reach out to local artists. Through this collaboration, we were able to work with local Asian American artists. We were also able to work with a CID small business owner, Tom Dang, who likes to paint as a hobby.



PROJECT HISTORY & SCHEDULE

2019 - 2020

2019: SCIDpda awarded grant from the Office of Economic Development

2020: 4 artists selected to paint 4 murals

2020: artists paint murals

2020: completed murals are stored in storefronts of the Louisa Apartments building in the Maynard Alley

2023

April: SCIDpda awarded 5k from Historic South Downtown's Arts and Culture grant

May: mural installation contractor and mural locations selected

July: ISRD review

July-August: 4 murals installed in Maynard Alley

August: mural installation celebration

THE MURALS

Mural Dimensions: 4' x 5'



Pantone Warm Red C
Hex: #F9423A
RGB: (249,66,58)



Pantone 158 C
Hex: #E87722
RGB: (232,119,34)



Pantone 280 C
Hex: #012169
RGB: (1,33,105)



Pantone 549 C
Hex: #6BA4B8
RGB: (107,164,184)



Pantone Neutral Black C
Hex: #222223
RGB: (34,34,35)

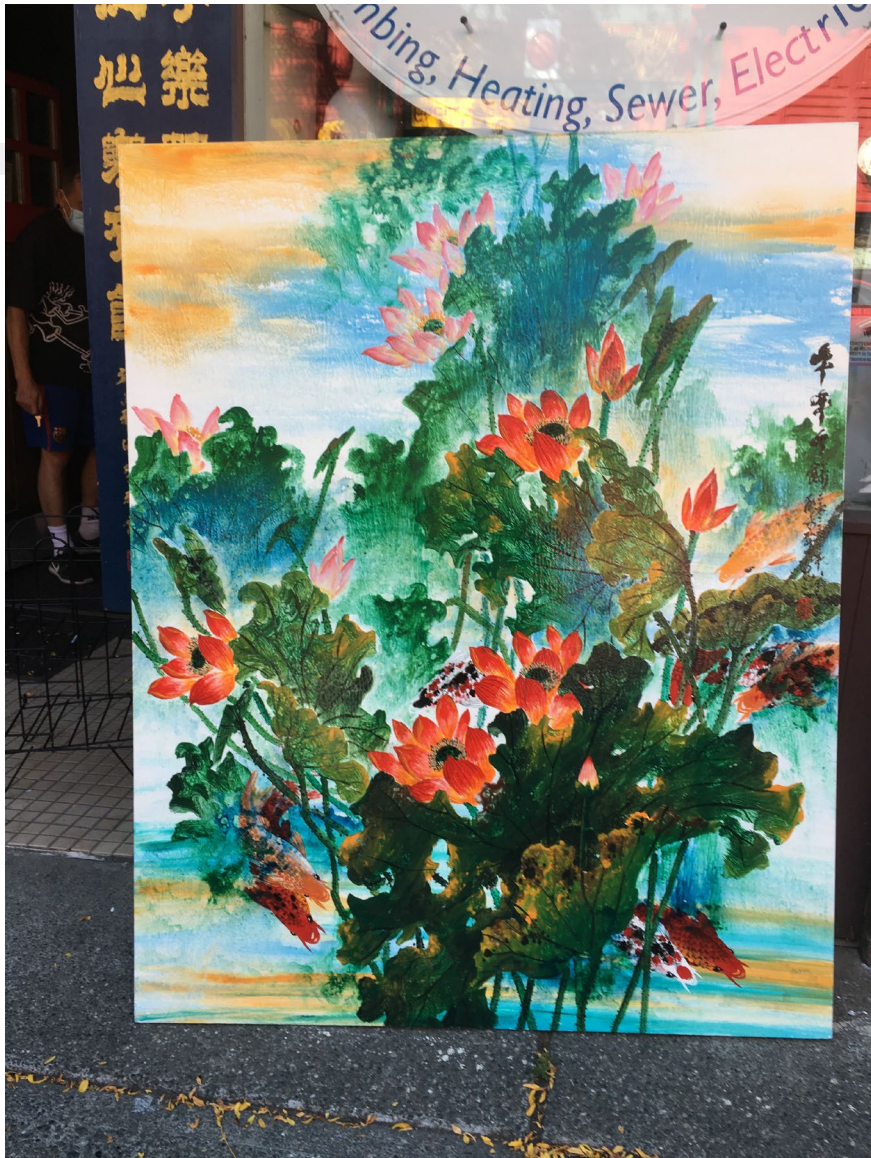

THE MURALS

Mural Dimensions: 4' x 5'



Pantone 560 C
Hex: #1D3C34
RGB: (29,60,52)



Pantone 173 C
Hex: #CF4520
RGB: (207,69,32)



Pantone 135 C
Hex: #FFC658
RGB: (255,198,88)

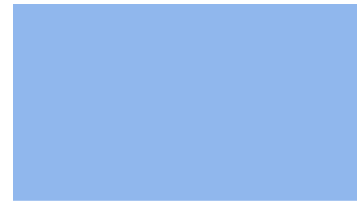

Pantone 278 C
Hex: #8BB8E8
RGB: (139,184,232)



Pantone 349 C
Hex: #046A38
RGB: (4,106,56)



THE MURALS

Mural Dimensions: 4' x 5'



Pantone 1635 C
Hex: #FF8D6D
RGB: (255,141,109)



Pantone 367 C
Hex: #A4D65E
RGB: (164,214,94)



Pantone 346 C
Hex: #71CC98
RGB: (113,204,152)



Pantone Orange 021 C
Hex: #FE5000
RGB: (254,80,0)



Pantone Neutral Black C
Hex: #222223
RGB: (34,34,35)



THE MURALS

Mural Dimensions: 4' x 5'



Pantone 7473 C
Hex: #279989
RGB: (39,153,137)



Pantone 7407 C
Hex: #CBA052
RGB: (203,160,82)



Pantone 144 C
Hex: #ED8B00
RGB: (237,139,0)



Pantone 2166 C
Hex: #57728B
RGB: (87,114,139)



Pantone 400 C
Hex: #C4BFB6
RGB: (196,191,182)



PRESENT

The murals have been stored in the alley storefronts of the Louisa building for the past 2 years

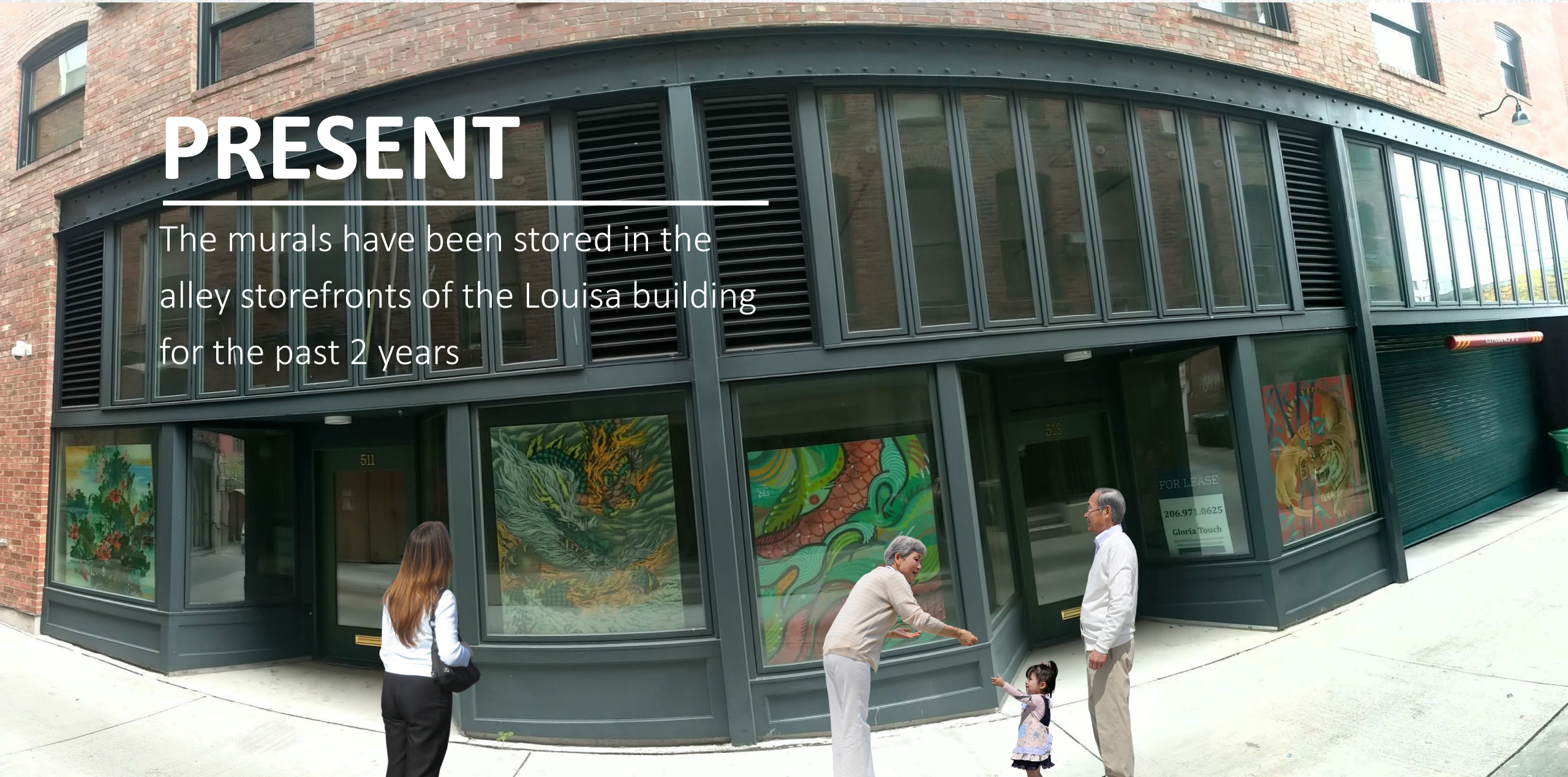

MURAL SITE



New Central Apartments Wall

MURAL ATTACHMENT DETAILS



MURAL ATTACHMENT DETAILS

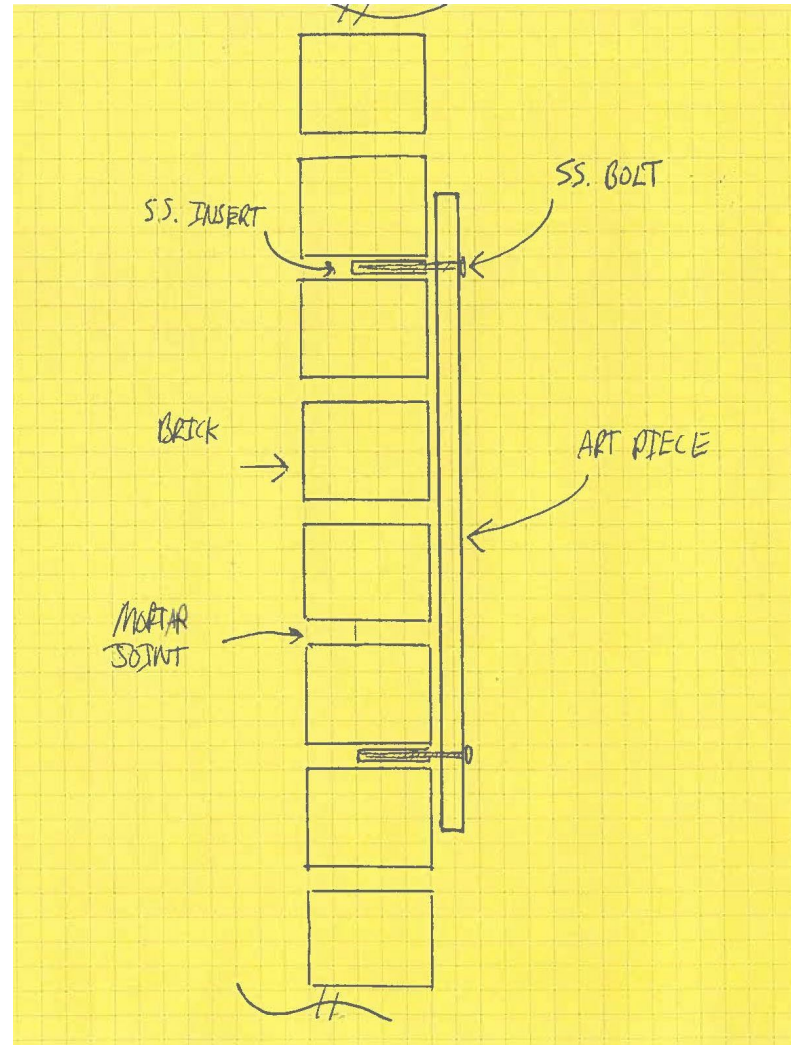

FUTURE

Murals along the New Central Apartments.



ART PRECEDENT IN MAYNARD ALLEY



SLURP MURAL GOING ACROSS KING STREET AND INTO MAYNARD ALLEY



PRECEDENTS

Art works in other alleys in the Chinatown International District and the neighboring Pioneer Square neighborhood



**NIHONMACHI
ALLEY (CID)**

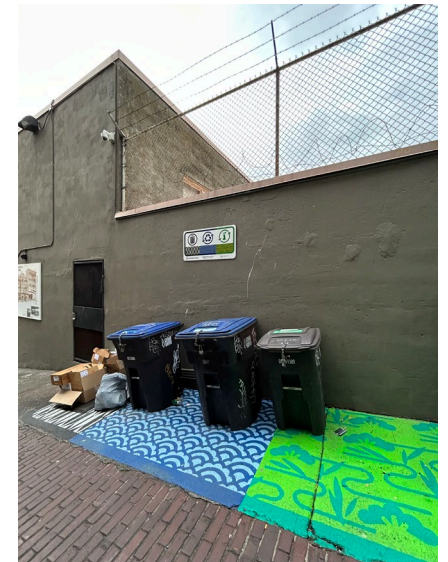

PRECEDENTS

Art works in other alleys in the Chinatown International District and the neighboring Pioneer Square neighborhood



**CANTON ALLEY
(CID)**

PRECEDENTS

Art works in other alleys in the Chinatown International District and the neighboring Pioneer Square neighborhood



**NORD ALLEY
(PIONEER SQUARE)**