



**TACTICS**

**B O A R D S H O P**

TACTICS BOARDSHOP BLADE SIGN PLAN  
Site Location

Proposed sign location:  
5209 Ballard Ave NW, 98107

\*will replace existing blade sign





**ASCENT**  
**OUTDOORS**

SALES & SERVICE - SINCE 1996



**ASCENT**  
**OUTDOORS**

SALES & SERVICE - SINCE 1996



*Pike*  
TAPROOM

**TACTICS BOARDSHOP BLADE SIGN PLAN**  
5209 Ballard Ave NW, 98107

DISTANCE  
FROM TOP EDGE  
OF SIGN TO  
GROUND- 144"

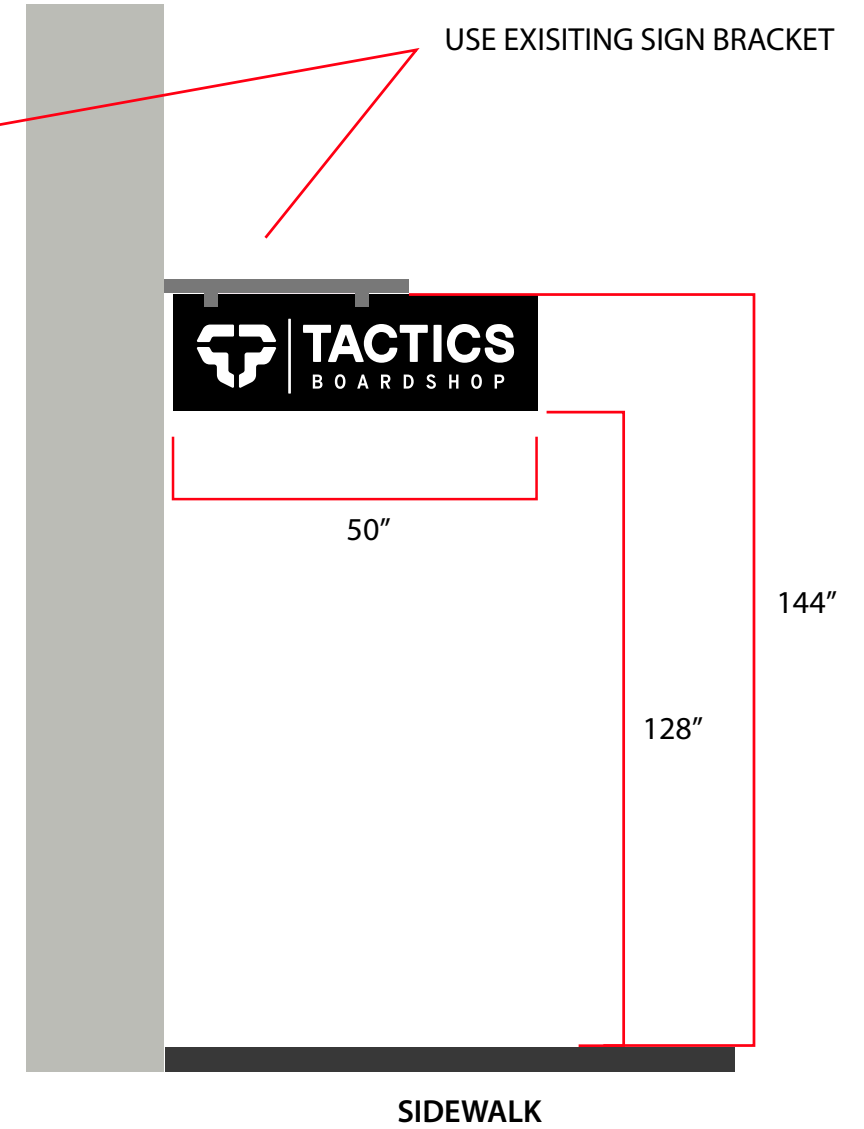

**TACTICS BOARDSHOP BLADE SIGN PLAN**  
**Sign Specifications**

Overall Sign Dimensions:  
50" wide  
16" tall  
3/4" thick- painted black

Handpainted on sealed  
High Density MDF

All edges and inner mounting holes  
will be sealed to prevent decomposition.

All surfaces of sign, including edge will be  
sealed/painted black using Acrylic latex enamel.

Paints used:  
Background:  
Acrylic Latex Interior/external enamel  
Black 6509-00731

Lettering and Logo:  
1Shot Lettering Enamel  
101L Lettering White

EXISTING SIGN BRACKET- 35.5"



TACTICS BOARDSHOP BLADE SIGN PLAN  
Sign Composites

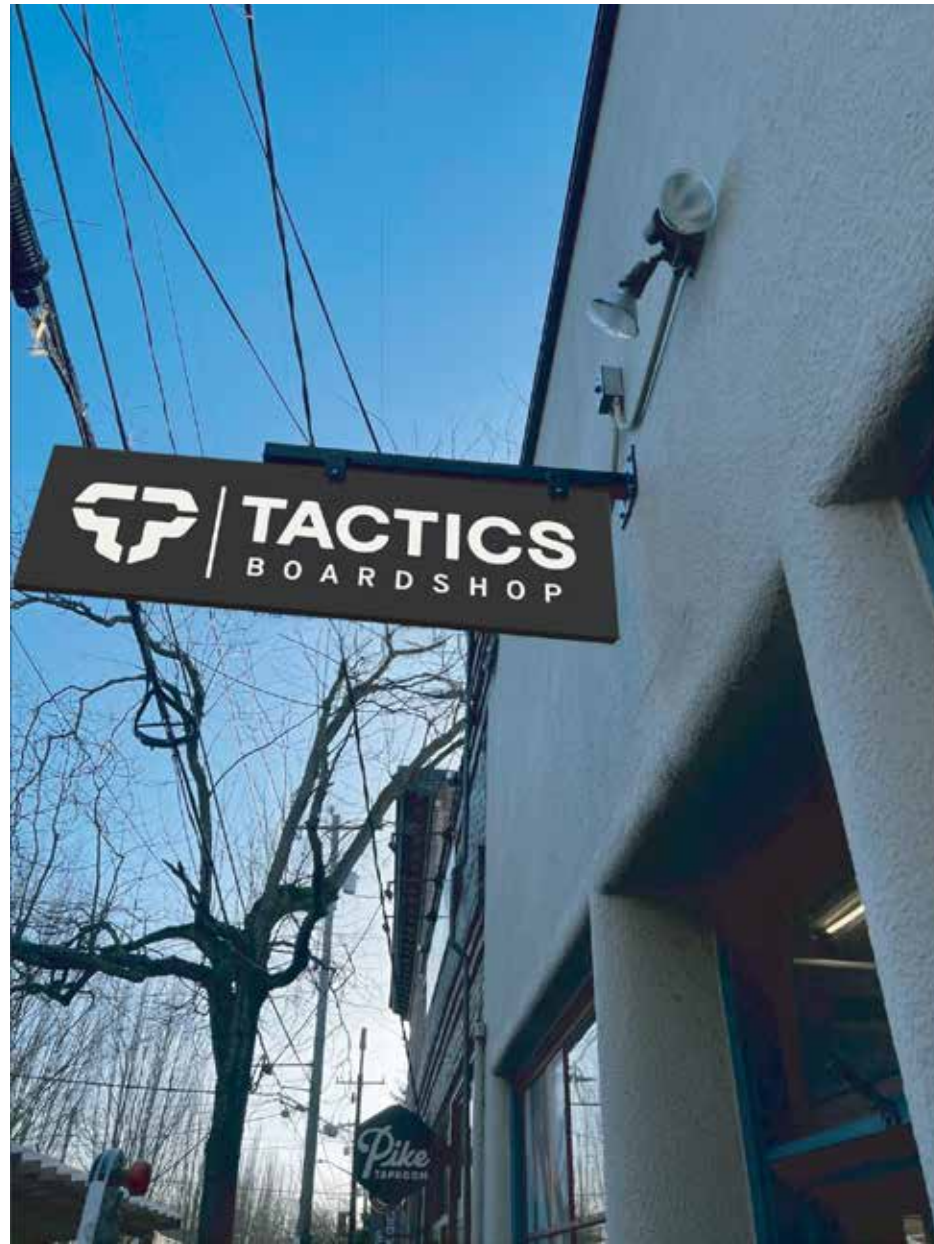

# PRIMARY COLORS

## EVERGREEN

PANTONE: 554C  
CMYK: 80,44,83,44  
RGB: 41,79,52  
HEX: #294F34

## OBSIDIAN

PANTONE: BLACK 2C  
CMYK: 70,65,68,77  
RGB: 30,29,26  
HEX: #1E1D1A

## STONE

PANTONE: 7527C  
CMYK: 8,6,13,0  
RGB: 232,231,219  
HEX: #E8E6DA



# SECONDARY COLORS

## CHANTERELLE

PANTONE: 715C  
CMYK: 9,55,78,0  
RGB: 224,135,77  
HEX: #E0874D

## SAGE

PANTONE: 2260C  
CMYK: 38,4,57,0  
RGB: 165,202,141  
HEX: #A5CA8D





SALE



**NATHAN  
VITALE**

**P: MIKE MILLER**

B.D. [illegible]



FRZO

## **Shutter Information**

To be installed in the four windows that are in the photos taken from the store interior.

Photos are provided showing what they look like when installed and in use (from Portland, OR location).

The shutters are made of sheet metal and painted white. They are also “punched” to allow light and some visibility through.

There is a drawing which illustrates this in the “Curtain” section on the right side of each drawing. The punched holes are also visible in the Portland photos.

All the shutters are the same, other than their dimensions.

## **Installation Details**

The shutters will be affixed to the inside window frames, using metal screws. The screws will be hidden by a trim plate after installation. There will be a track on either side of each window, and a box above each shutter for storage when it's not in use. Importantly, all mounting hardware, tracks and the box will be invisible from outside the building. In other words, when the shutters are retracted, you will not see any hardware from outside, and when they are in use only the shutters themselves will be visible.

## **Operation**

The shutters will be open during business hours, which will be 11-7 – Mon-Sat and 11-6 on Sunday.

The shutters will be operated by a Tactics employee as part of their opening and closing duties.



SKI GEAR  
50% OFF

THIS SKI GEAR  
30% OFF

THIS SKI GEAR  
30% OFF

THIS SKI GEAR  
30% OFF

30% OFF  
THIS SKI GEAR

30% OFF  
THIS SKI GEAR

ASCENT  
OUTDOORS

JANUARY 10<sup>th</sup> - 20<sup>th</sup>  
**MOVING SALE!!**  
5209 BALLARD AVE NW

**40-50% OFF**  
ALL REMAINING INVENTORY

- SKIS, BOOTS, BINDINGS
- CAMPING & BACKPACKING
- APPAREL & FOOTWEAR
- SELECT CLIMBING GEAR

SEE STORE FOR DETAILS. WHILE SUPPLIES LAST. ©2014 ASCENT OUTDOORS

DIATH30

RUO  
YKOT-H  
WOM

40% off  
THIS SKI

40% off  
THIS



NINJA SUIT \*  
FOR THE BEST OF BOTH WORLDS



- NINJA SUIT 20
- NINJA SUIT 22
- NINJA SUIT 24
- NINJA SUIT 26
- NINJA SUIT 28
- NINJA SUIT 30
- NINJA SUIT 32
- NINJA SUIT 34
- NINJA SUIT 36
- NINJA SUIT 38
- NINJA SUIT 40
- NINJA SUIT 42
- NINJA SUIT 44
- NINJA SUIT 46
- NINJA SUIT 48
- NINJA SUIT 50





ASCENT  
JANUARY 10<sup>th</sup> - 20<sup>th</sup>  
**MOVING SALE!!**  
40% OFF  
2000 BALLAST  
T. SHIRTS  
S. BAGPACKING  
A. FOOTWEAR







TACTICS

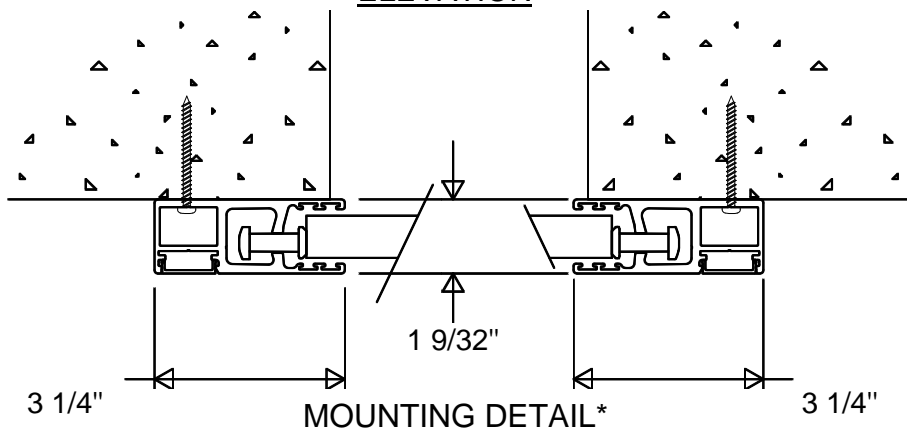
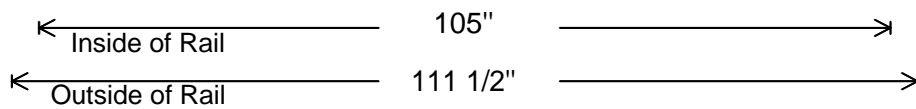
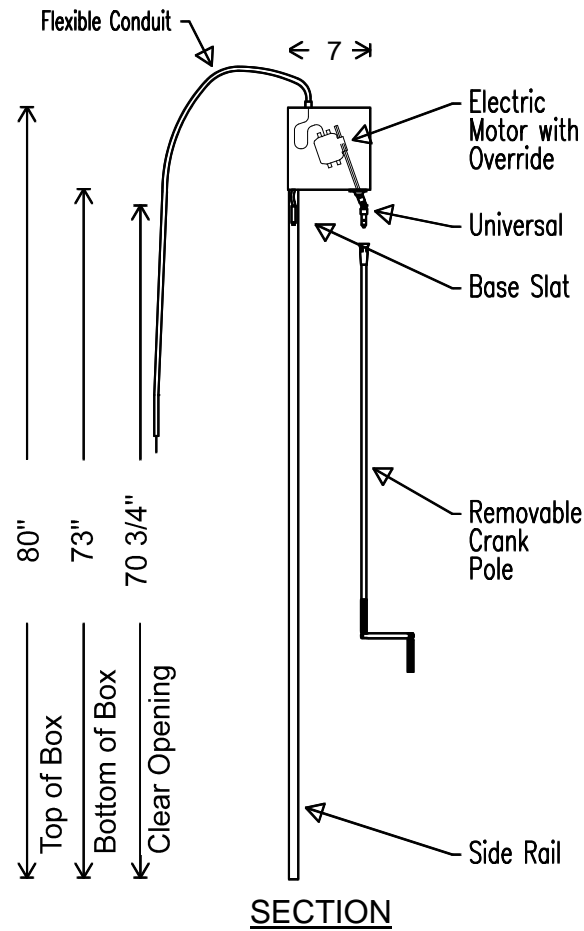
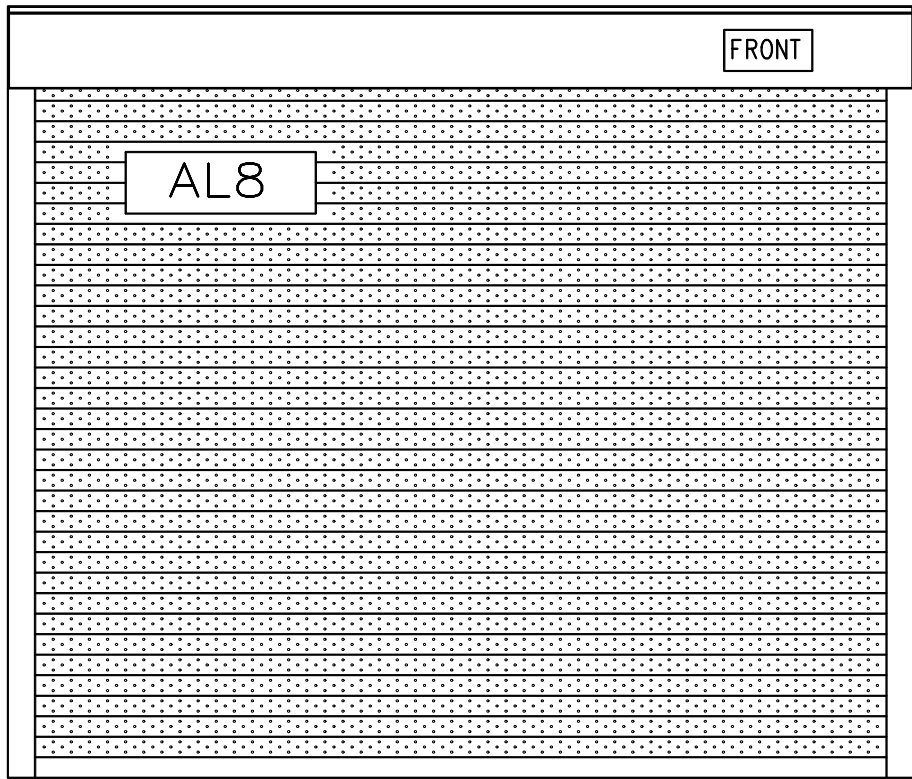

**LOCK \ STOP DETAIL**

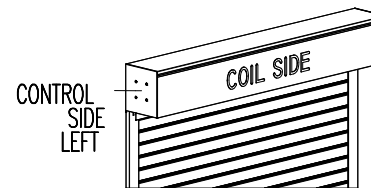

**CONTROL LOCATION**

**By:**  Approved for manufacture  
 Approved for manufacture as noted below  
 Make changes as noted below and resubmit

**Date:**

	YES	NO
Seacoast Application:	<input type="checkbox"/>	<input checked="" type="checkbox"/>
Hurricane Rated:*	<input type="checkbox"/>	<input checked="" type="checkbox"/>

<b>Width</b>	Inside of Rail:	105"	_____
	Outside of Rail:	111 1/2"	_____
<b>Height</b>	Clear Opening:	70 3/4"	_____
	Bottom of Box:	73"	_____
	Top of Box:	80"	_____
	Housing Size:	7	_____
<b>Color</b>	Rail:	WHITE	_____
	Housing:	WHITE	_____
	Slat:	WHITE	_____
	Base Slat:	WHITE	_____
<b>Curtain</b>	Slat Type:	SL8-2	_____
	Slat Style:	Punch 51	_____
	Curtain Weight:	55.0 lbs.	_____

<b>Control</b>	Control Side:	LEFT	_____
	Control Type:	EM-SA-520-O	_____

<b>Mounting</b>	Left Rail:	SURFACE DRILLED	_____
	Ø1: 1/2"    Ø2: 3/16"    ⌀ ~12"    ↗		
	Right Rail:	SURFACE DRILLED	_____
	Ø1: 1/2"    Ø2: 3/16"    ⌀ ~12"    ↗		
	Mounting Style:	WINDOW	_____

#: **209345-1 MWE** Date: **02/08/24**  
 Customer: **Adam Gerkin**  
 Job Name: **rolling shutters**  
 Shutter #: **1 of 4** QTY: **1**

**QMI** Ph 800 446 2500  
 Fax 630 980 6364

\*It shall be the responsibility of the contractor to verify the soundness of the structure where shutter is to be attached to insure proper anchorage.

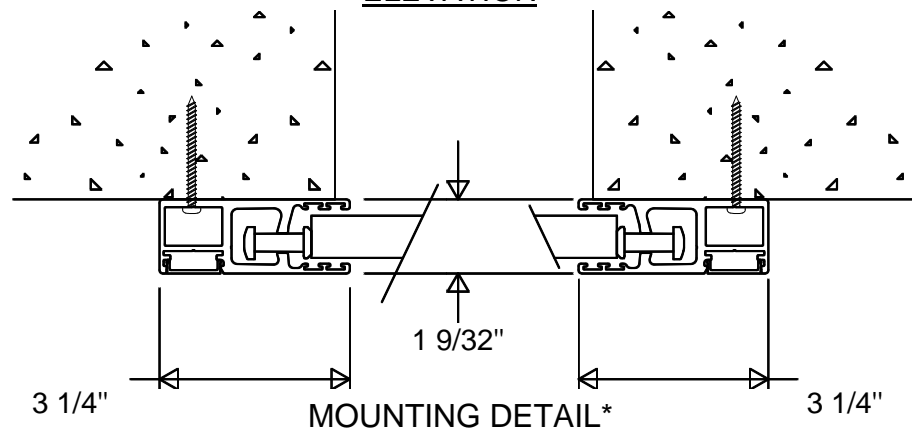
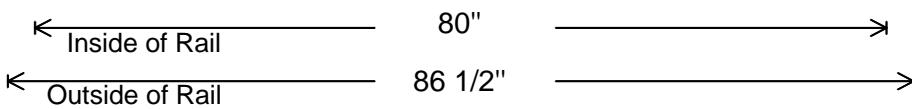
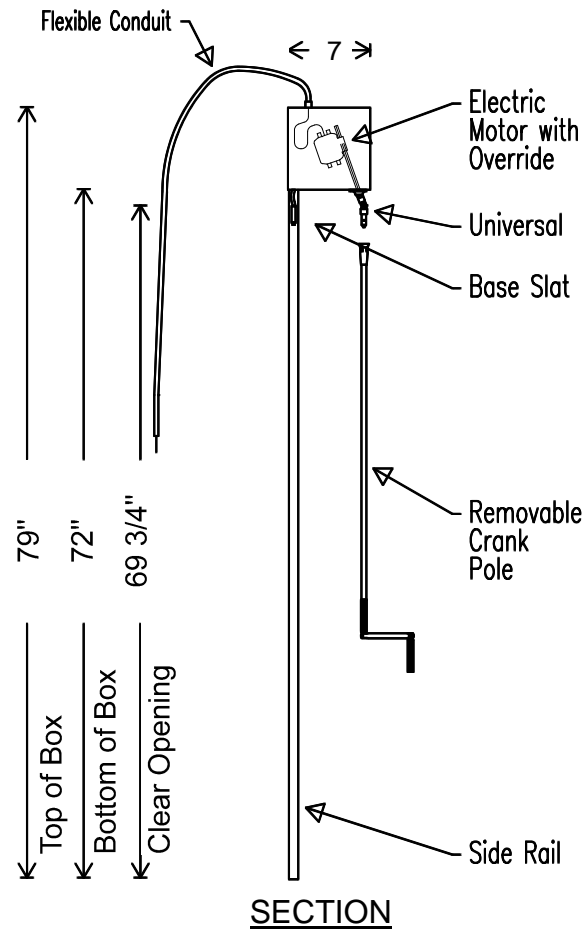
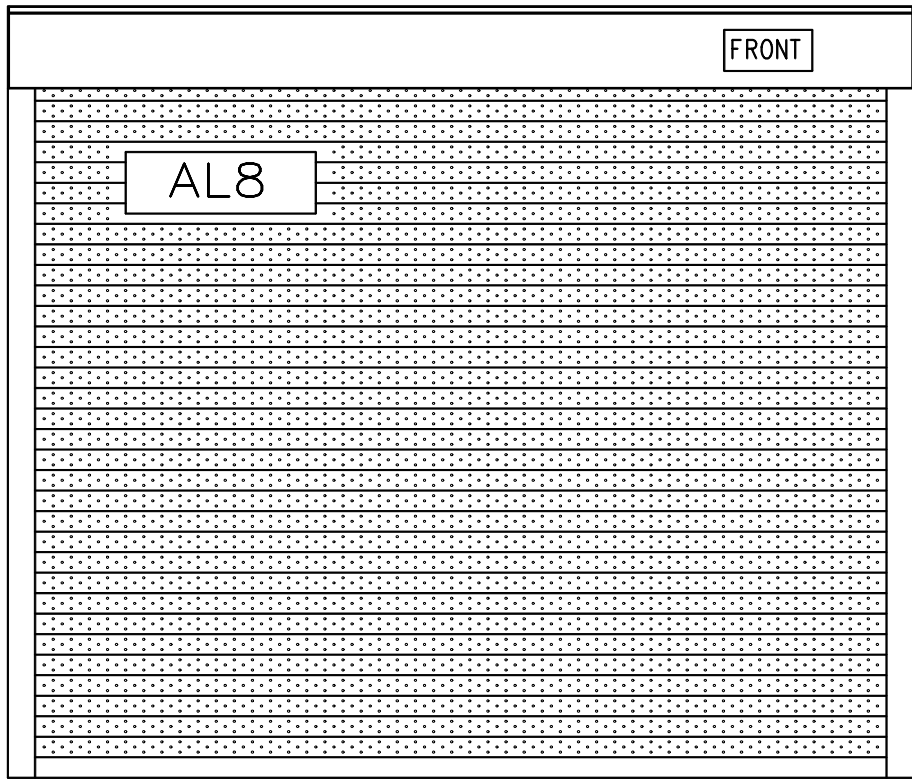

**LOCK \ STOP DETAIL**

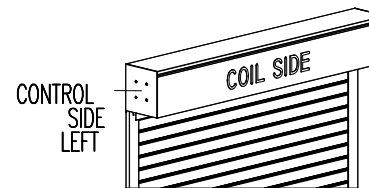

**CONTROL LOCATION**

**By:**  Approved for manufacture  
 Approved for manufacture as noted below  
 Make changes as noted below and resubmit

**Date:**

YES NO

Seacoast Application:

Hurricane Rated:\*

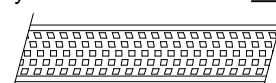
Width	Inside of Rail:	80"	_____
	Outside of Rail:	86 1/2"	_____
Height	Clear Opening:	69 3/4"	_____
	Bottom of Box:	72"	_____
	Top of Box:	79"	_____
	Housing Size:	7	_____
Color	Rail:	WHITE	_____
	Housing:	WHITE	_____
	Slat:	WHITE	_____
	Base Slat:	WHITE	_____
Curtain	Slat Type:	SL8-2	_____
	Slat Style:	Punch 51	_____
			
Curtain Weight:		45.0 lbs.	_____

Control	Control Side:	LEFT	_____
	Control Type:	EM-SA-520-O	_____

Mounting	Left Rail:	SURFACE DRILLED	_____
	Ø1: 1/2"	Ø2: 3/16"	⊕ ~12" ⊕
	Right Rail:	SURFACE DRILLED	_____
	Ø1: 1/2"	Ø2: 3/16"	⊕ ~12" ⊕
Mounting Style:		WINDOW	_____

#: **209345-1** MWE Date: **02/08/24**

Customer: **Adam Gerkin**

Job Name: **rolling shutters**

Shutter #: **2 of 4** QTY: **1**

 **QMI** Ph 800 446 2500  
 Fax 630 980 6364

\*It shall be the responsibility of the contractor to verify the soundness of the structure where shutter is to be attached to insure proper anchorage.

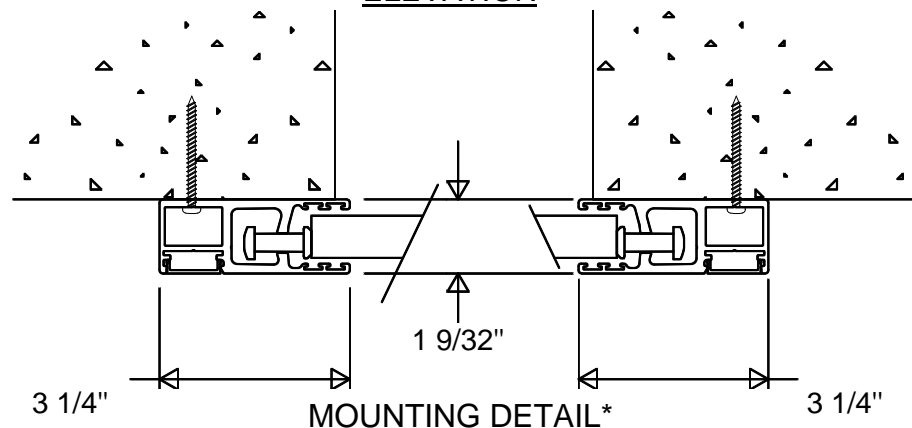
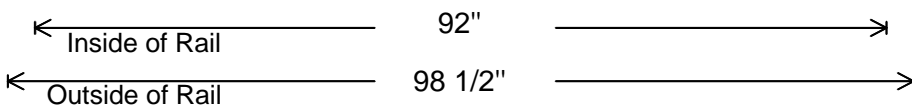
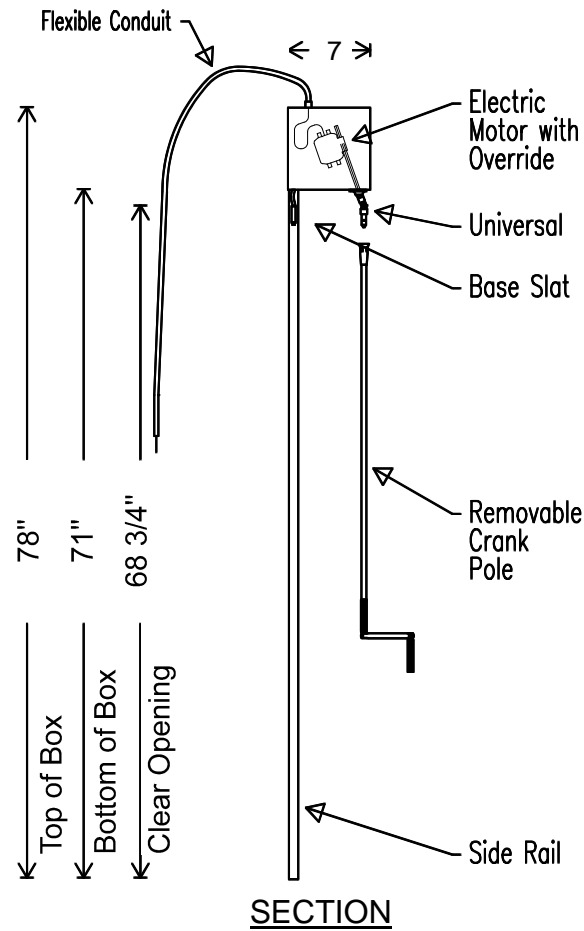
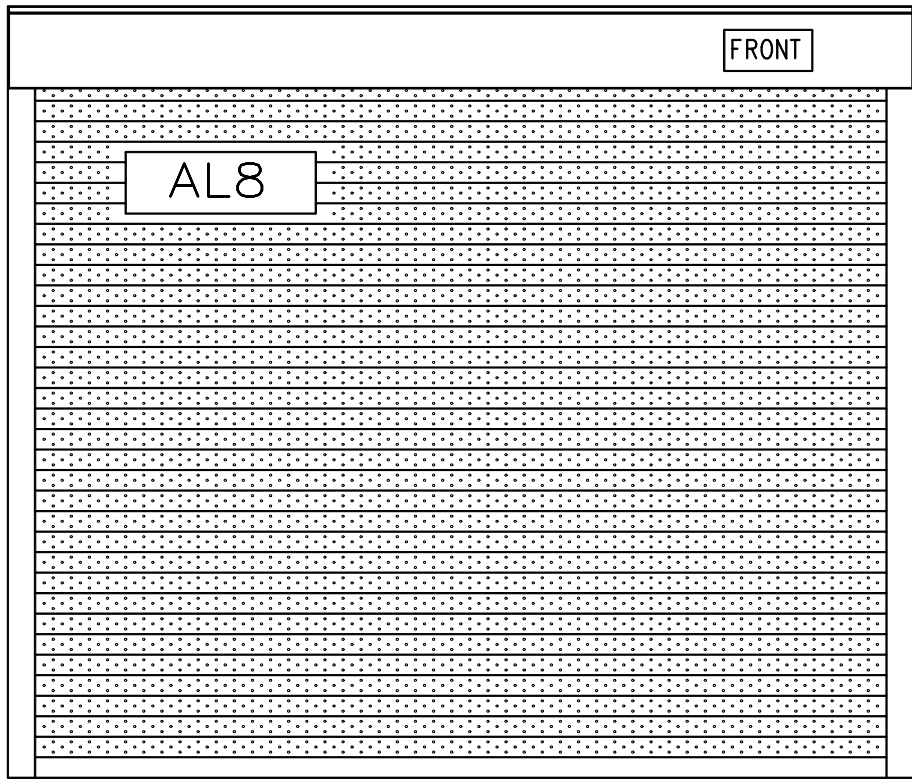

**LOCK \ STOP DETAIL**

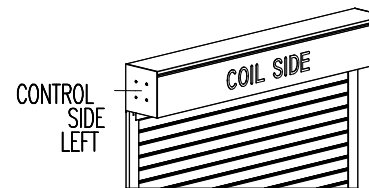

**CONTROL LOCATION**

**By:**  Approved for manufacture  
 Approved for manufacture as noted below  
 Make changes as noted below and resubmit

**Date:**

Seacoast Application: YES  NO

Hurricane Rated:\* YES  NO

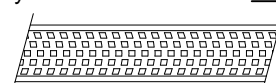
Width	Inside of Rail:	92"	_____
	Outside of Rail:	98 1/2"	_____
Height	Clear Opening:	68 3/4"	_____
	Bottom of Box:	71"	_____
	Top of Box:	78"	_____
	Housing Size:	7	_____
Color	Rail:	WHITE	_____
	Housing:	WHITE	_____
	Slat:	WHITE	_____
	Base Slat:	WHITE	_____
Curtain	Slat Type:	SL8-2	_____
	Slat Style:	Punch 51	_____
			
		Curtain Weight:	51.0 lbs.

Control	Control Side:	LEFT	_____
	Control Type:	EM-SA-520-O	_____

Mounting	Left Rail:	SURFACE DRILLED	_____
	Ø1: 1/2" Ø2: 3/16" ⌀ ~12" ↗		
	Right Rail:	SURFACE DRILLED	_____
		Ø1: 1/2" Ø2: 3/16" ⌀ ~12" ↗	
		Mounting Style:	WINDOW

#: **209345-1 MWE** Date: **02/08/24**  
 Customer: **Adam Gerkin**  
 Job Name: **rolling shutters**  
 Shutter #: **3 of 4** QTY: **1**

 Ph 800 446 2500  
 Fax 630 980 6364

\*It shall be the responsibility of the contractor to verify the soundness of the structure where shutter is to be attached to insure proper anchorage.

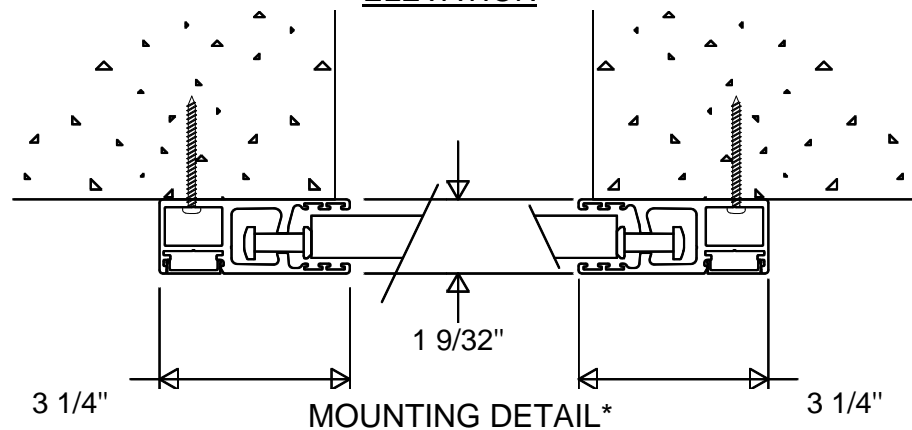
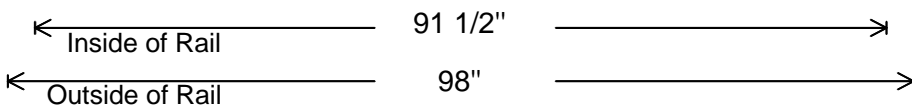
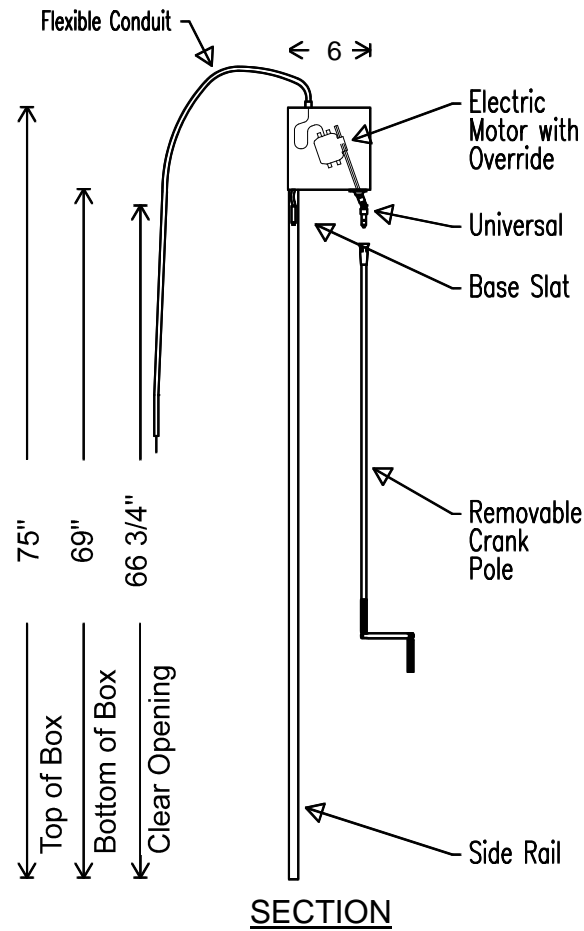
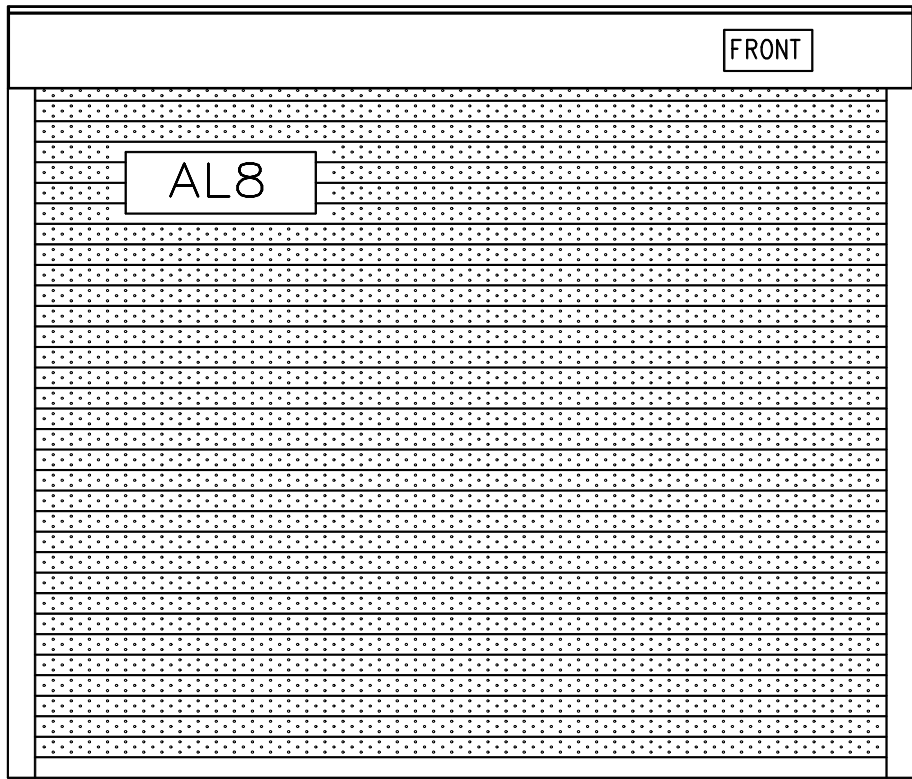

LOCK \ STOP DETAIL

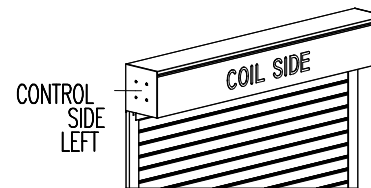

CONTROL LOCATION

By:  Approved for manufacture  
 Approved for manufacture as noted below  
 Make changes as noted below and resubmit

Date: YES NO

Seacoast Application:    
Hurricane Rated:\*

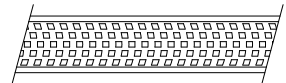
Width	Inside of Rail:	91 1/2"	_____
	Outside of Rail:	98"	_____
Height	Clear Opening:	66 3/4"	_____
	Bottom of Box:	69"	_____
	Top of Box:	75"	_____
	Housing Size:	6	_____
Color	Rail:	WHITE	_____
	Housing:	WHITE	_____
	Slat:	WHITE	_____
	Base Slat:	WHITE	_____
Curtain	Slat Type:	SL8-2	_____
	Slat Style:	Punch 51	_____
			
Curtain Weight:		49.0 lbs.	_____

Control	Control Side:	LEFT	_____
	Control Type:	EM-SA-520-O	_____

Mounting	Left Rail:	SURFACE DRILLED	_____
	Ø1: 1/2" Ø2: 3/16" ⌀ ~12" ⚡		_____
	Right Rail:	SURFACE DRILLED	_____
		Ø1: 1/2" Ø2: 3/16" ⌀ ~12" ⚡	_____
Mounting Style:		WINDOW	_____

#: **209345-1** MWE Date: **02/08/24**  
Customer: **Adam Gerkin**  
Job Name: **rolling shutters**  
Shutter #: **4 of 4** QTY: **1**

\*It shall be the responsibility of the contractor to verify the soundness of the structure where shutter is to be attached to insure proper anchorage.